



(19) **United States**

(12) **Patent Application Publication**
Goodman

(10) **Pub. No.: US 2011/0286724 A1**

(43) **Pub. Date: Nov. 24, 2011**

(54) **MODULAR THERMAL ENERGY
RETENTION AND TRANSFER SYSTEM**

(52) **U.S. Cl. 392/346; 165/10; 165/104.13;
165/104.31**

(76) **Inventor: Travis Goodman, Oliver Springs,
TN (US)**

(57) **ABSTRACT**

(21) **Appl. No.: 12/783,174**

Described is a modular thermal energy transfer system. The modular thermal energy transfer system includes a plurality of modular thermal units having a thermal retainer with a conditioning pipe and a usable fluid pipe disposed therein. The conditioning pipes are in fluidic communication with one another, and the usable fluid pipes are in fluidic communication with one another. The conditioning pipes are adapted to carry a conditioning fluid therethrough and to allow transfer of thermal energy between the thermal retainers and the conditioning fluid. The usable fluid pipes are adapted to carry a usable fluid therethrough and to allow the transfer of thermal energy between the thermal retainers and the usable fluid. The various thermal retainers of the modular thermal units are configured to be positionable proximate one another such that thermal energy is transferable between substantially adjacent thermal retainers.

(22) **Filed: May 19, 2010**

Publication Classification

(51) **Int. Cl.**
F24H 7/04 (2006.01)
F28D 15/00 (2006.01)
F28D 17/00 (2006.01)

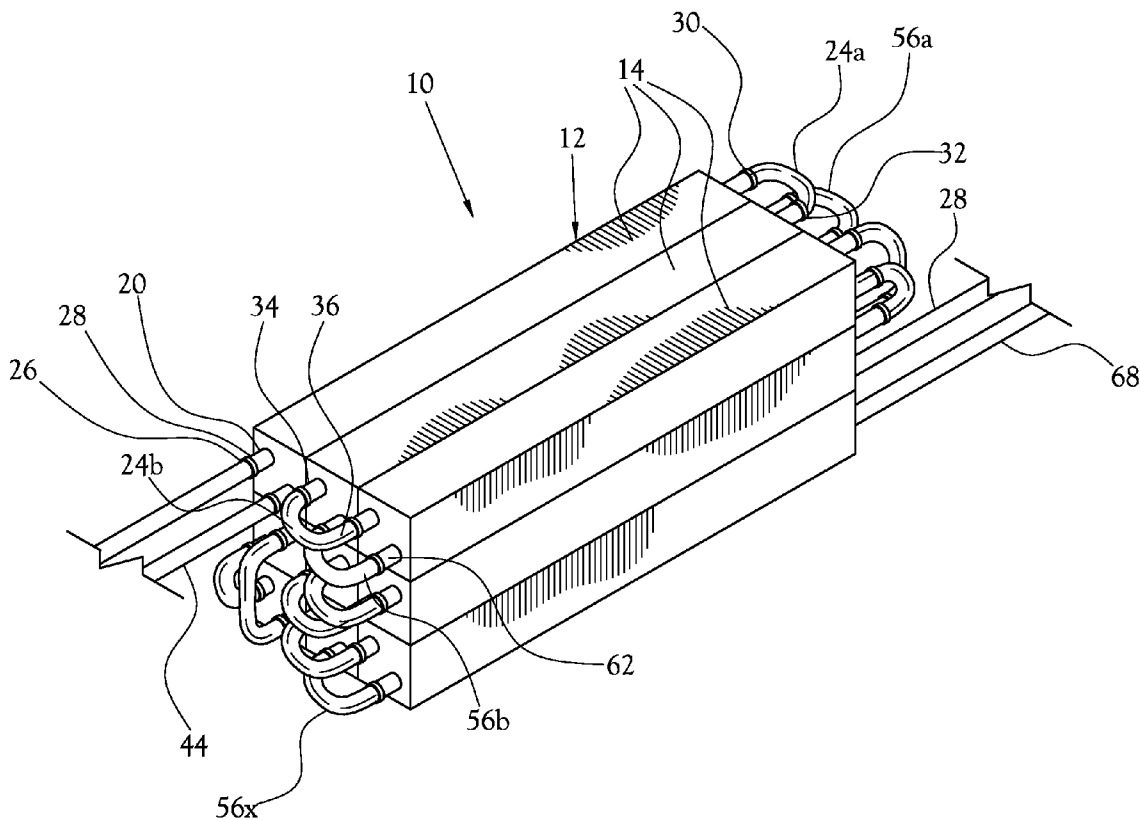

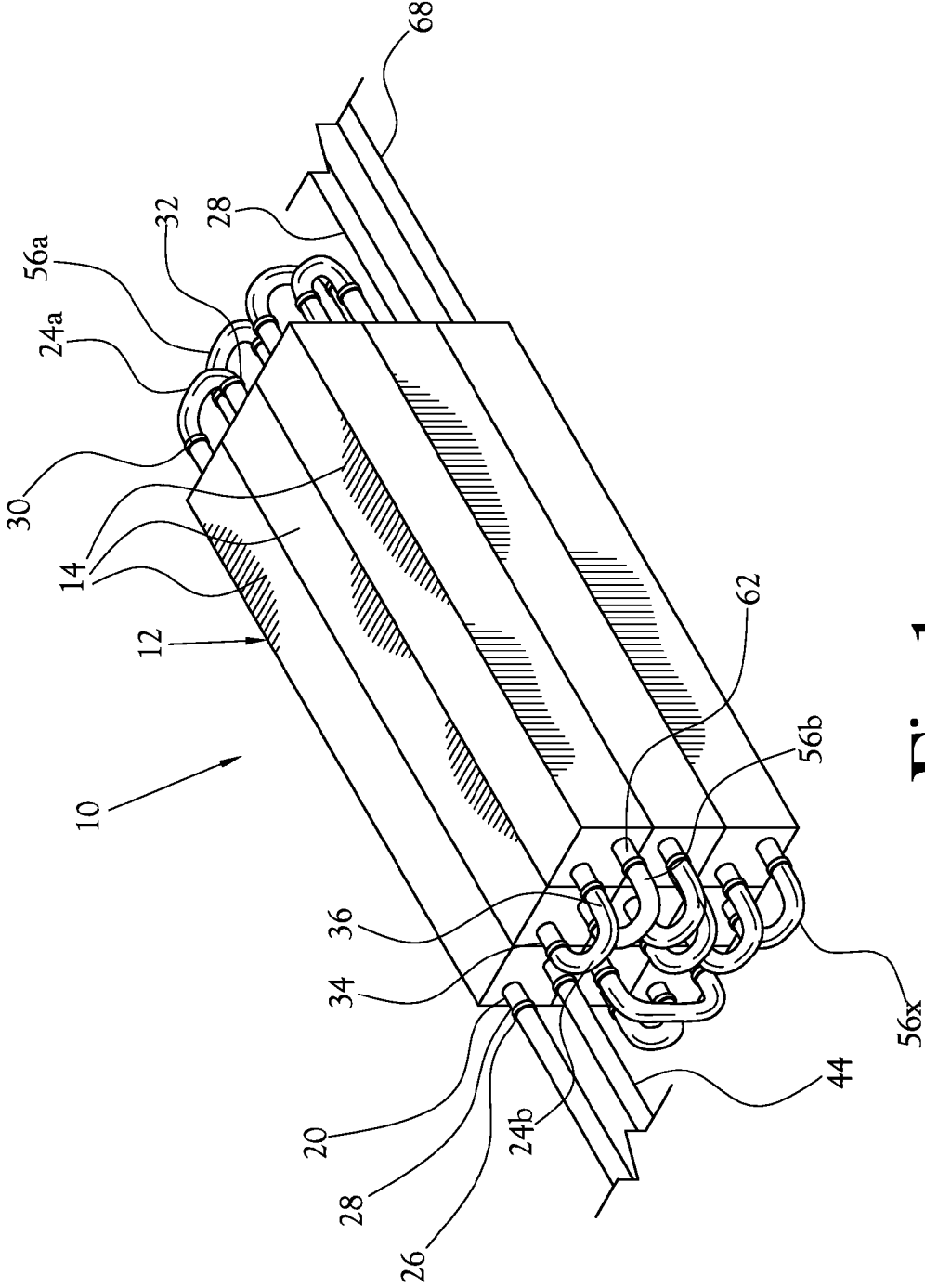

Fig. 1

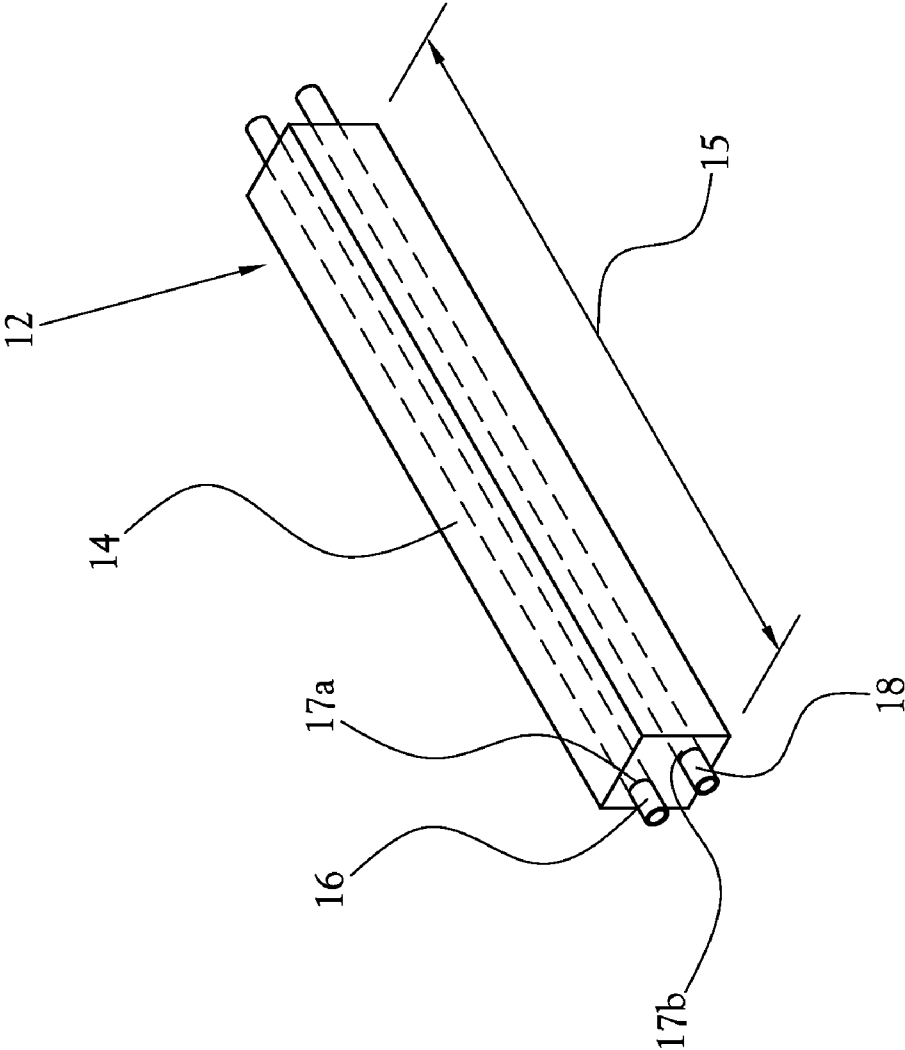

Fig. 2

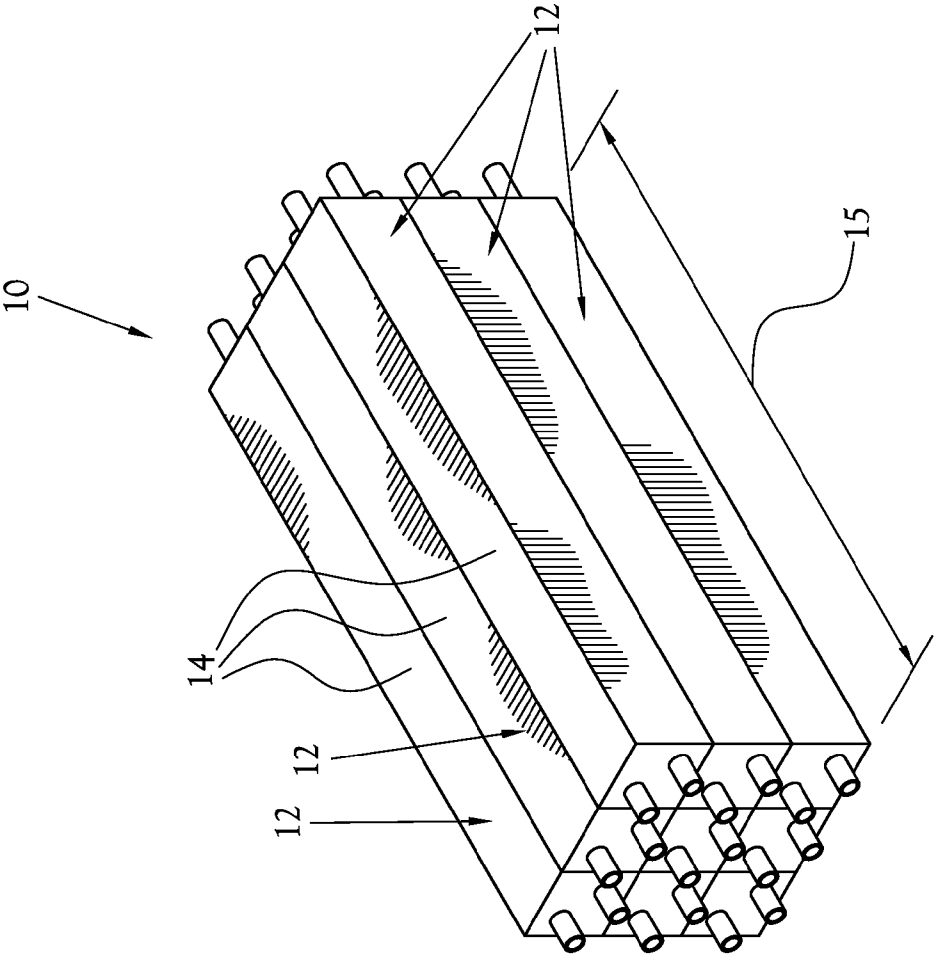

Fig. 3

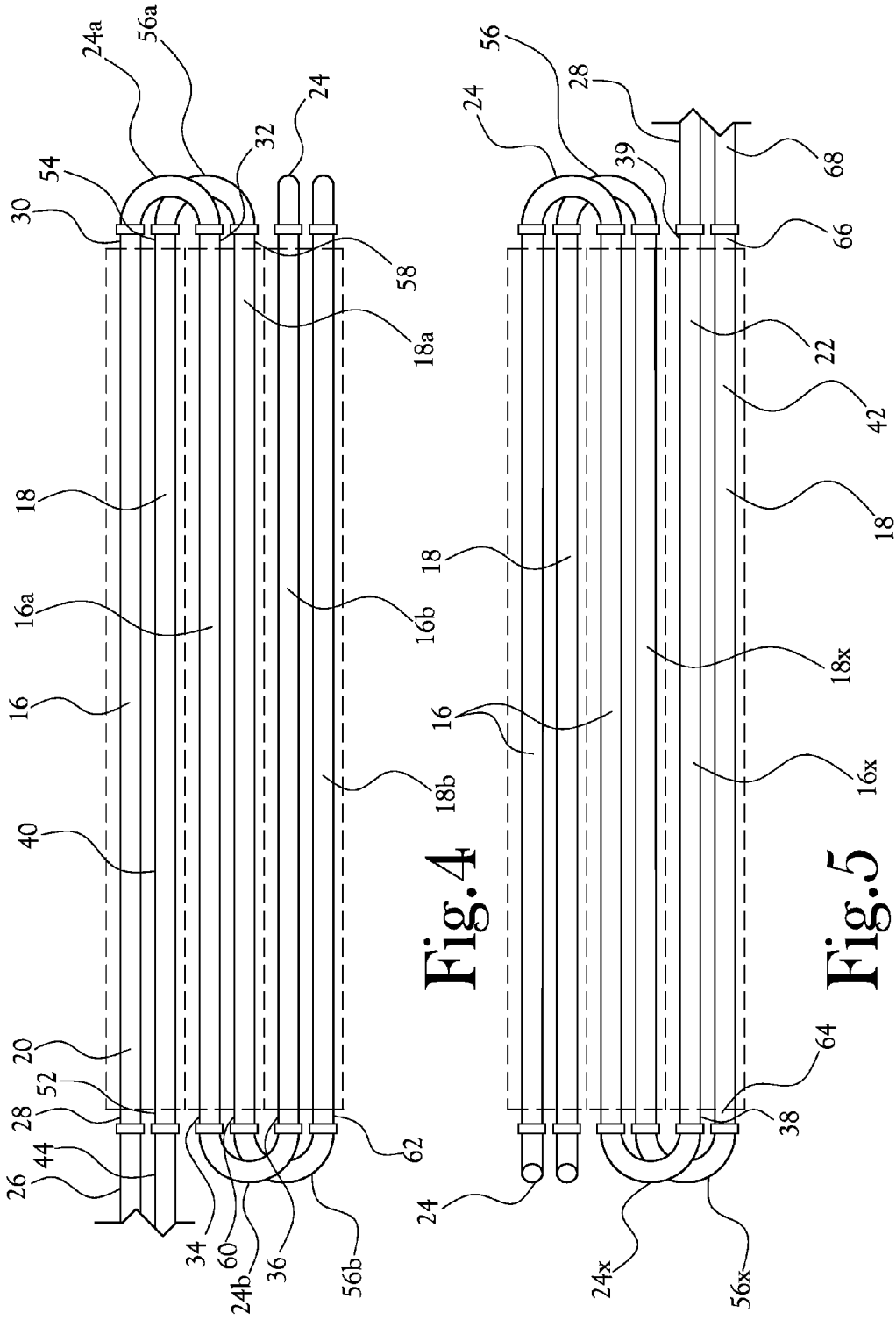

Fig. 4

Fig. 5

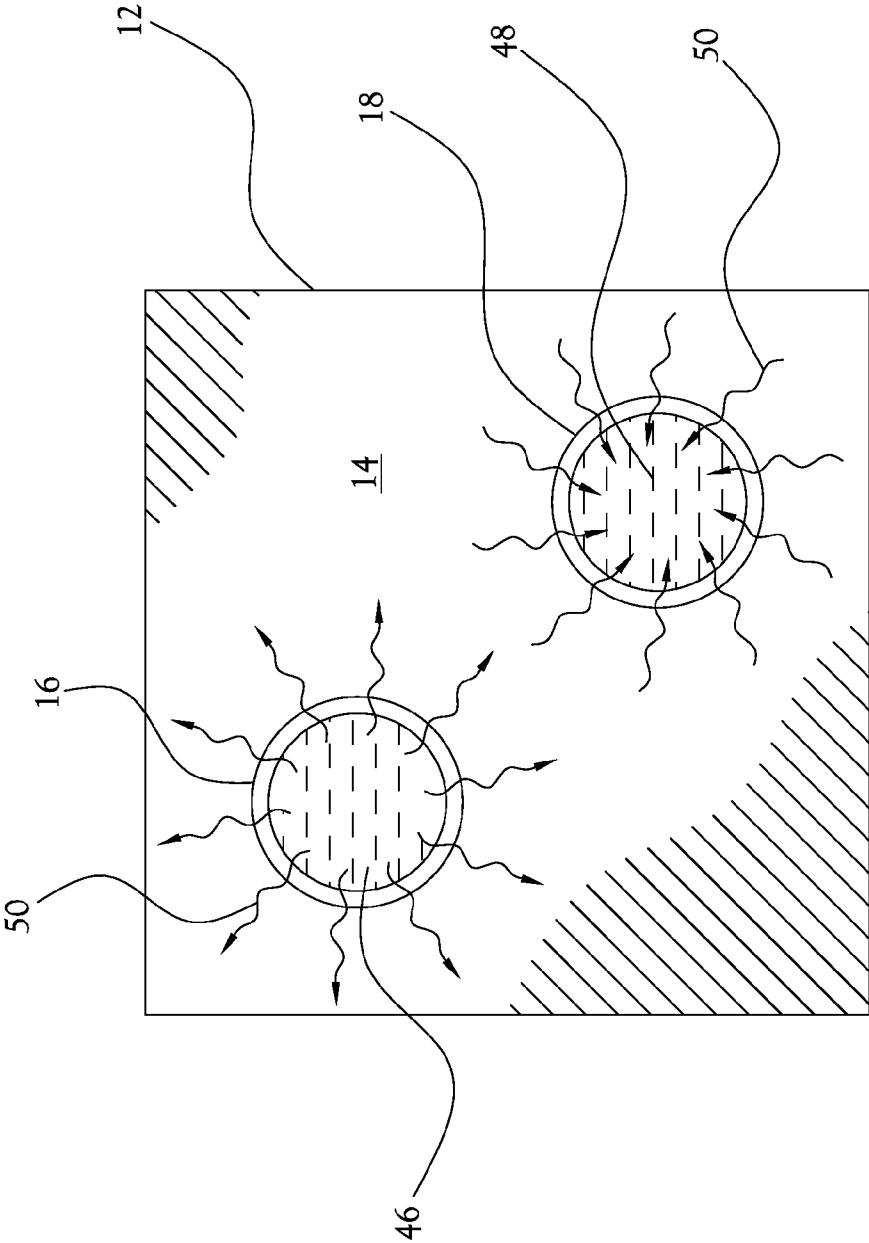

Fig.6

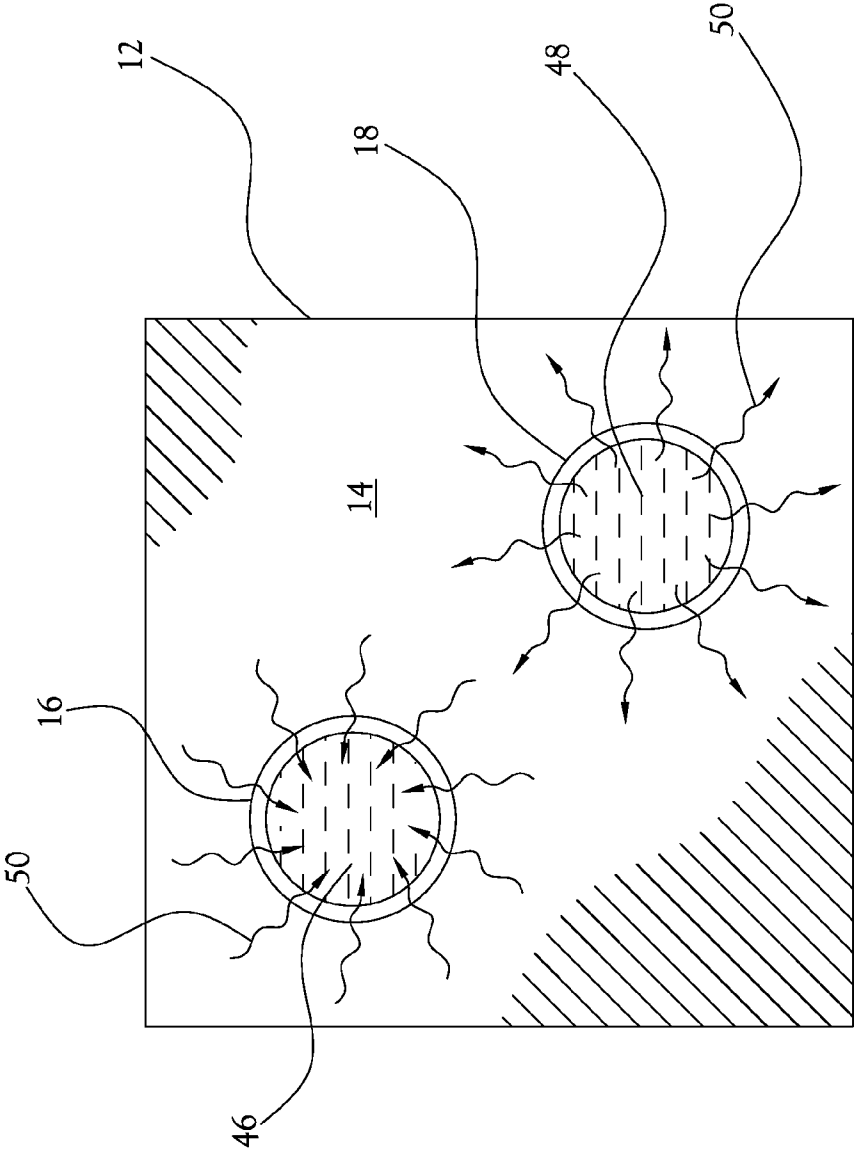

Fig. 7

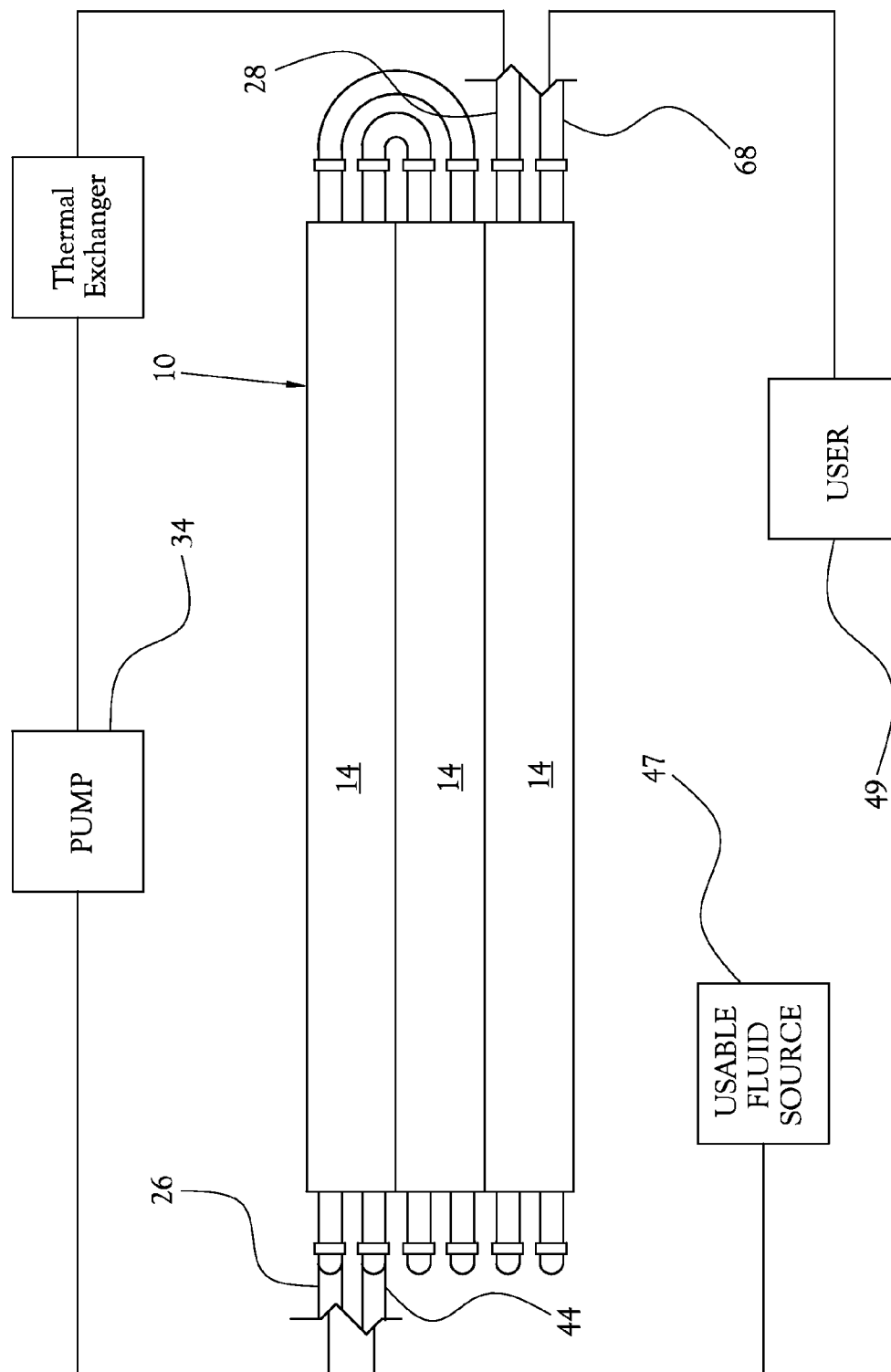

Fig. 8

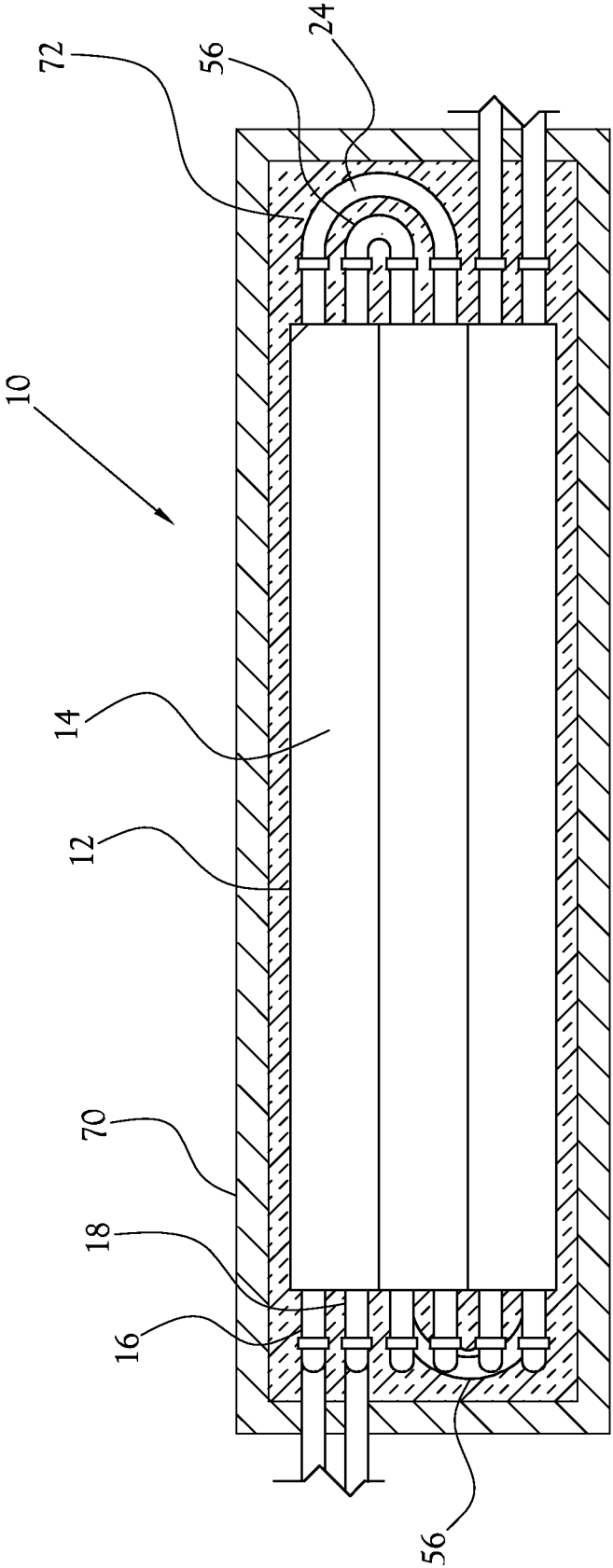

Fig. 9

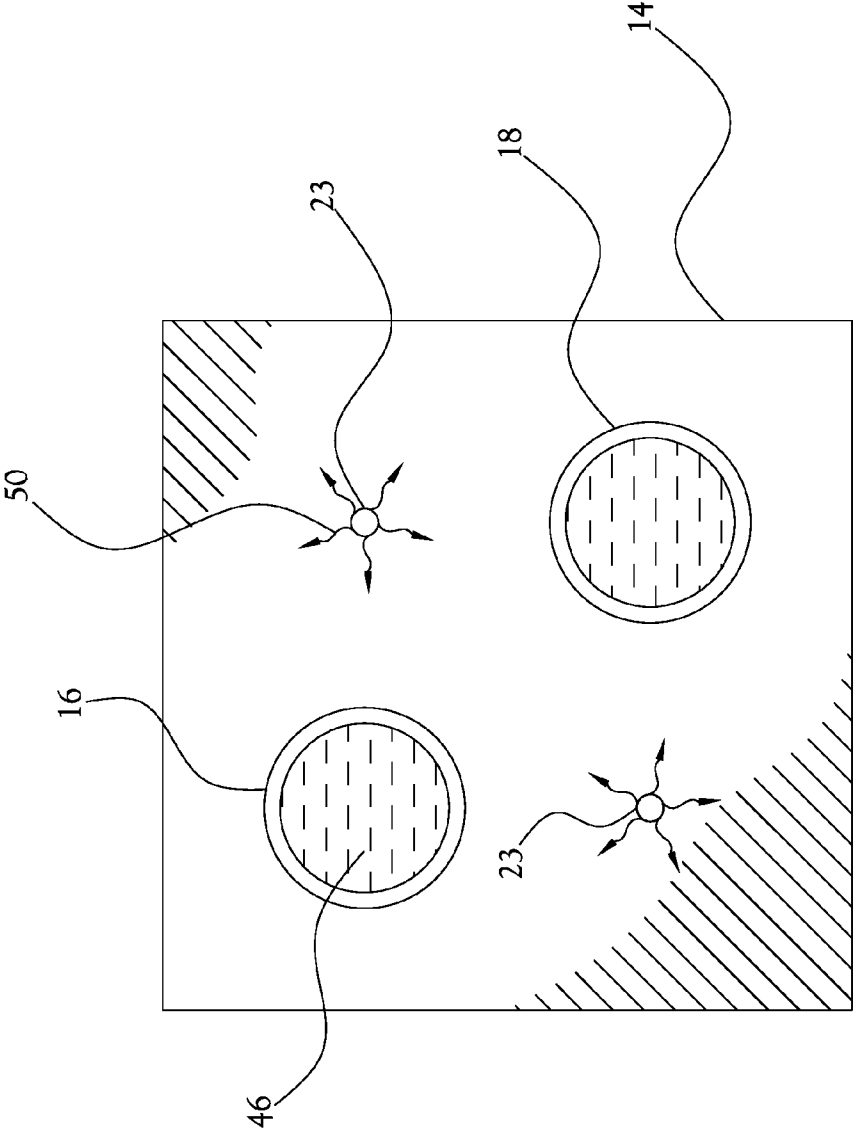

Fig. 10a

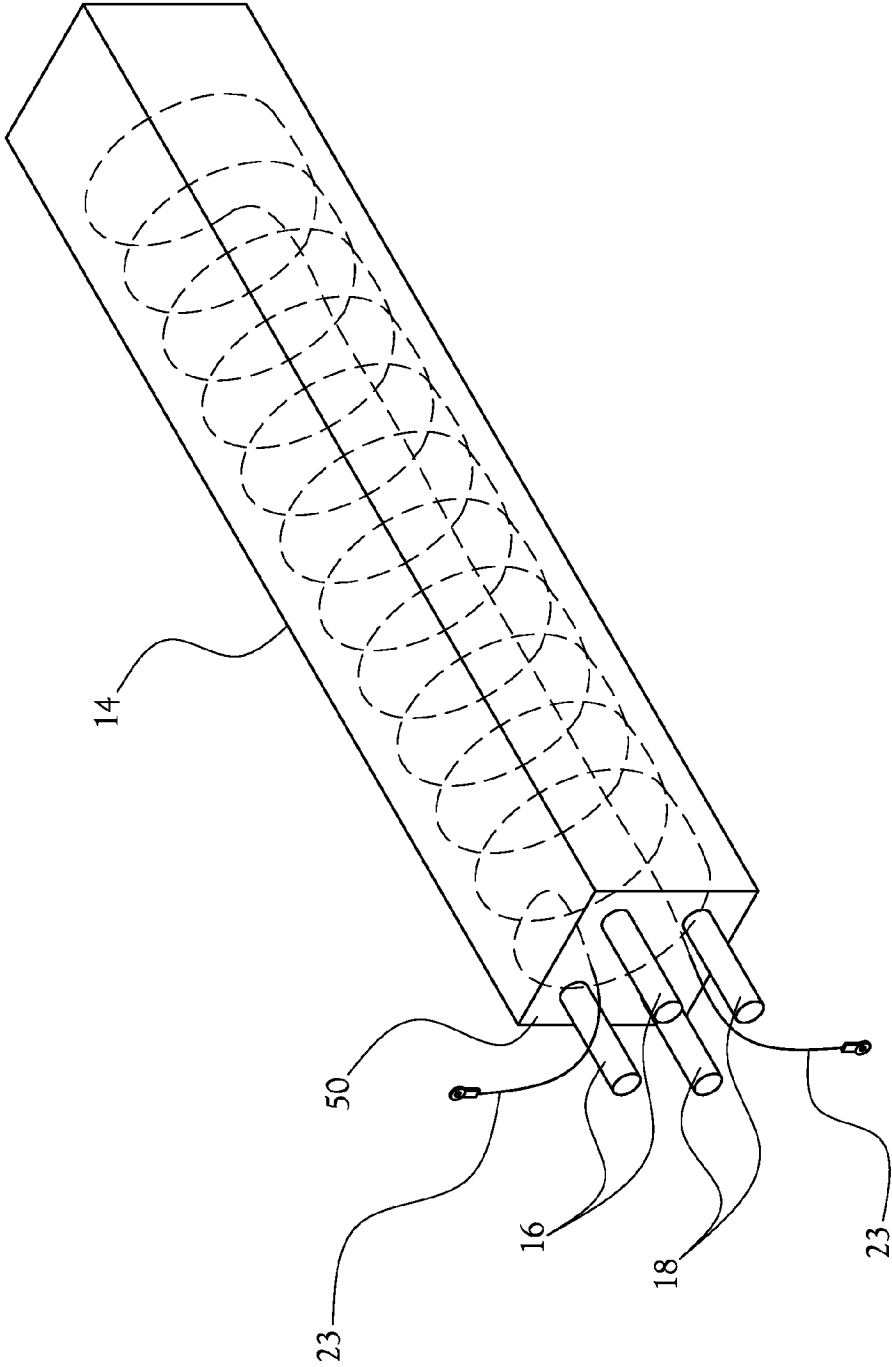

Fig. 10b

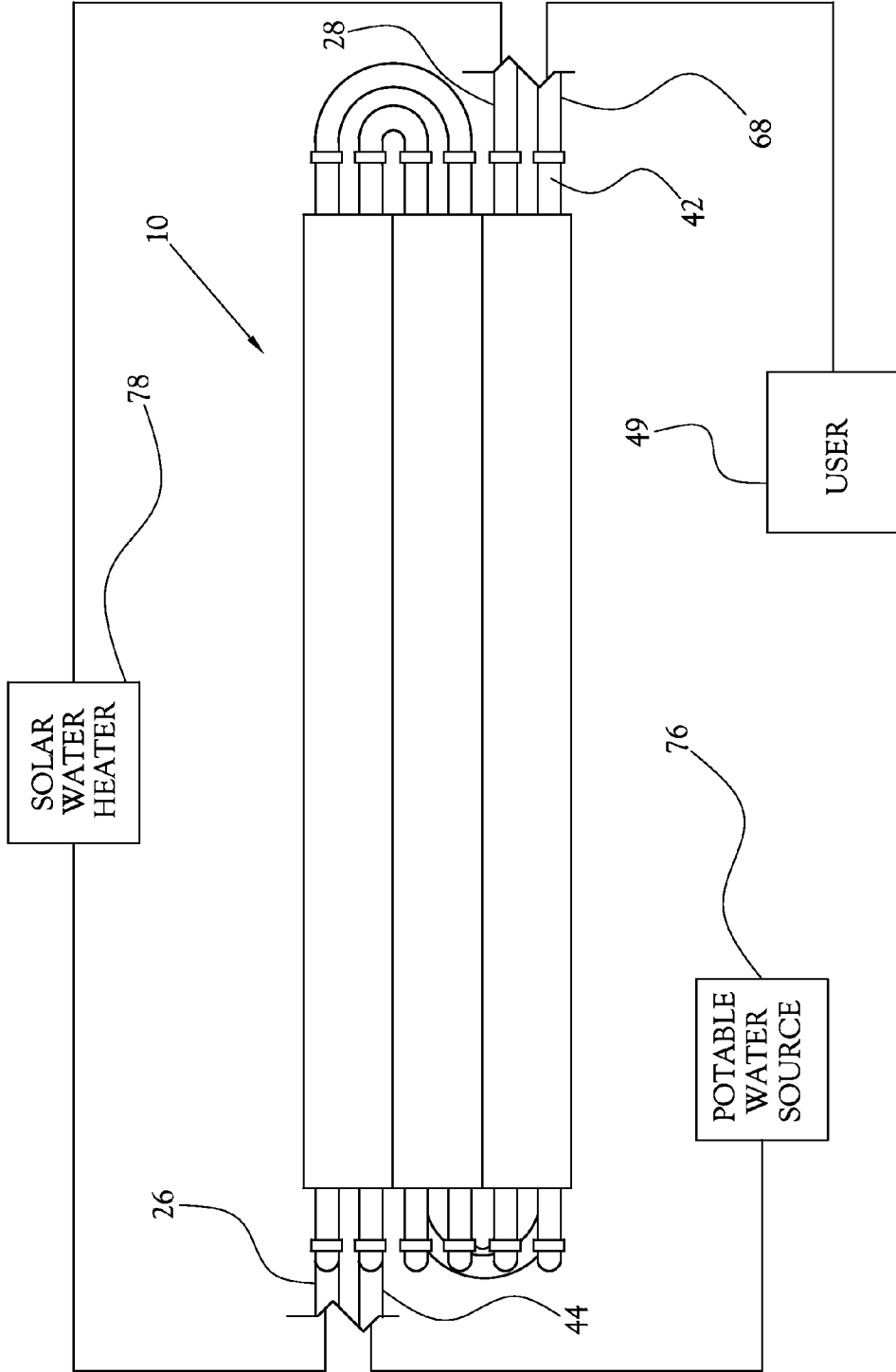

Fig. 11

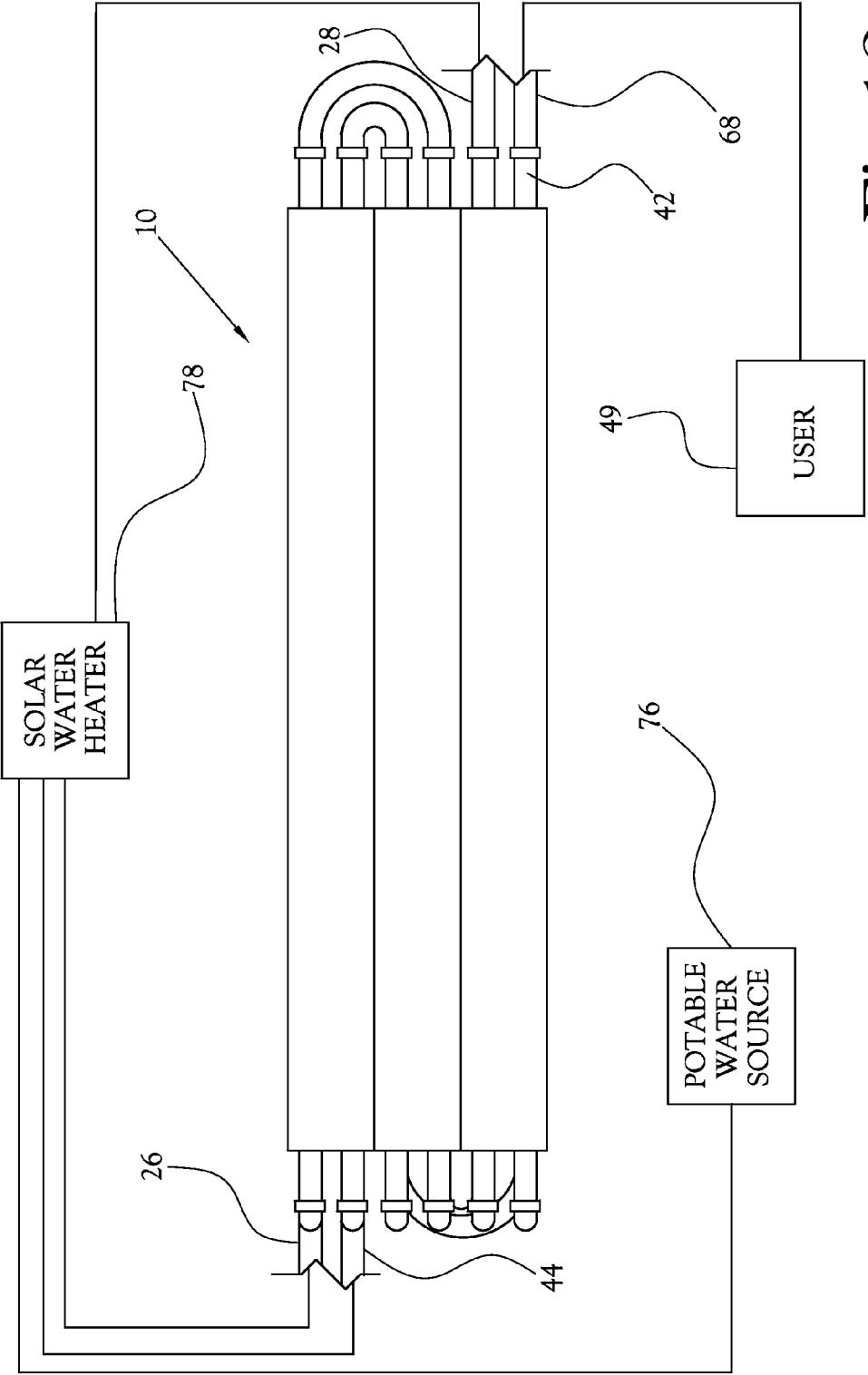

Fig. 12

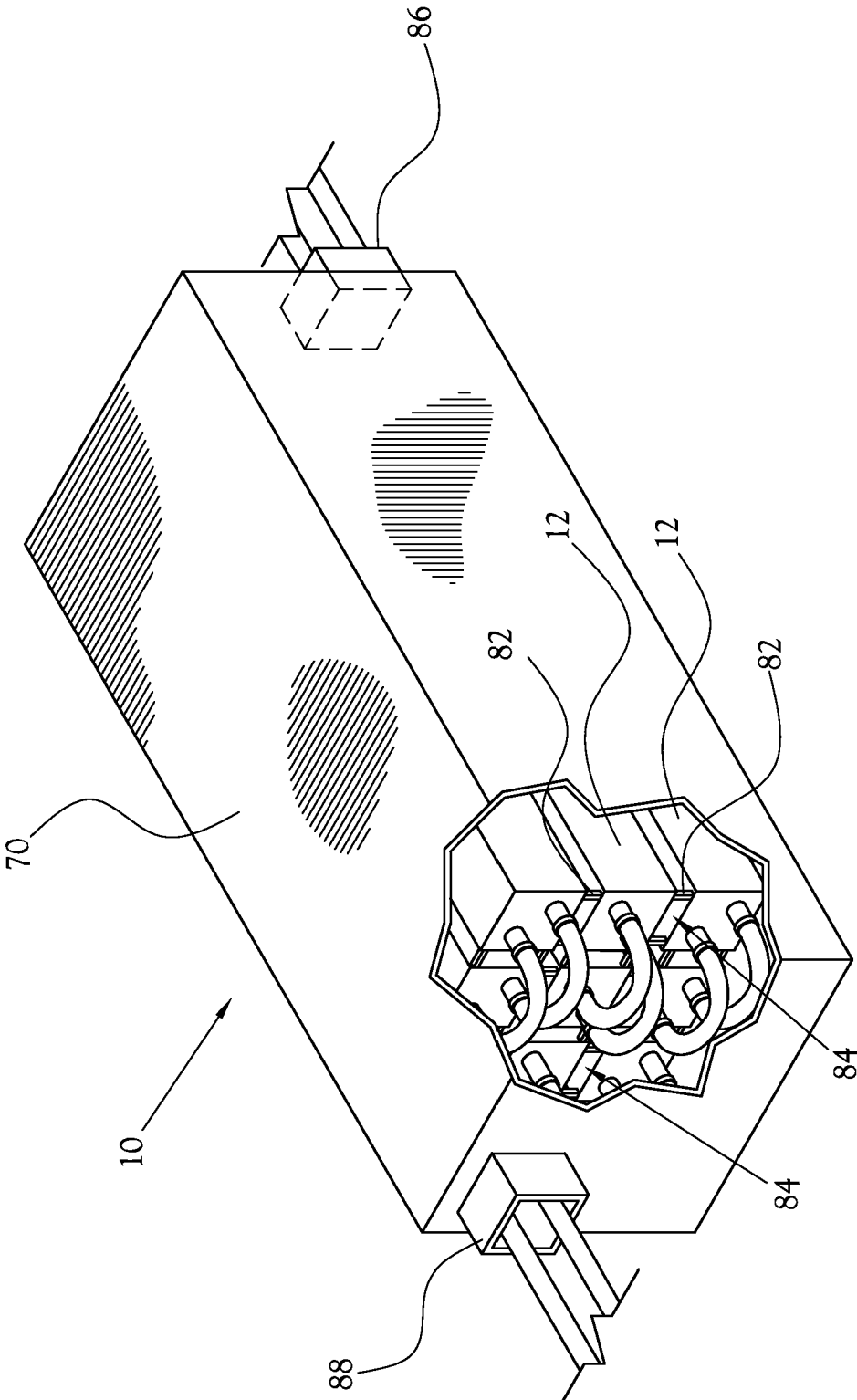

Fig. 13

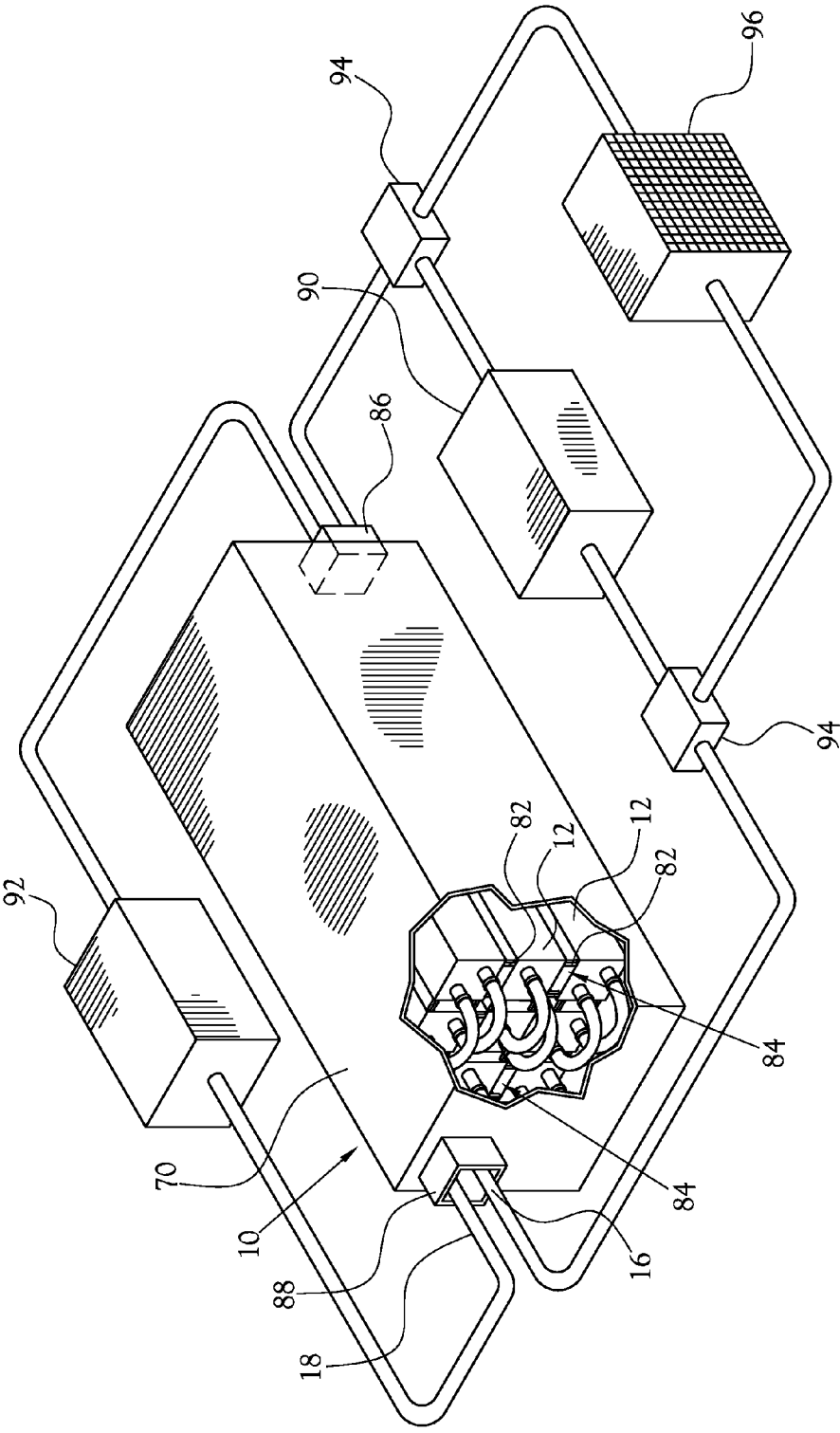

Fig. 14

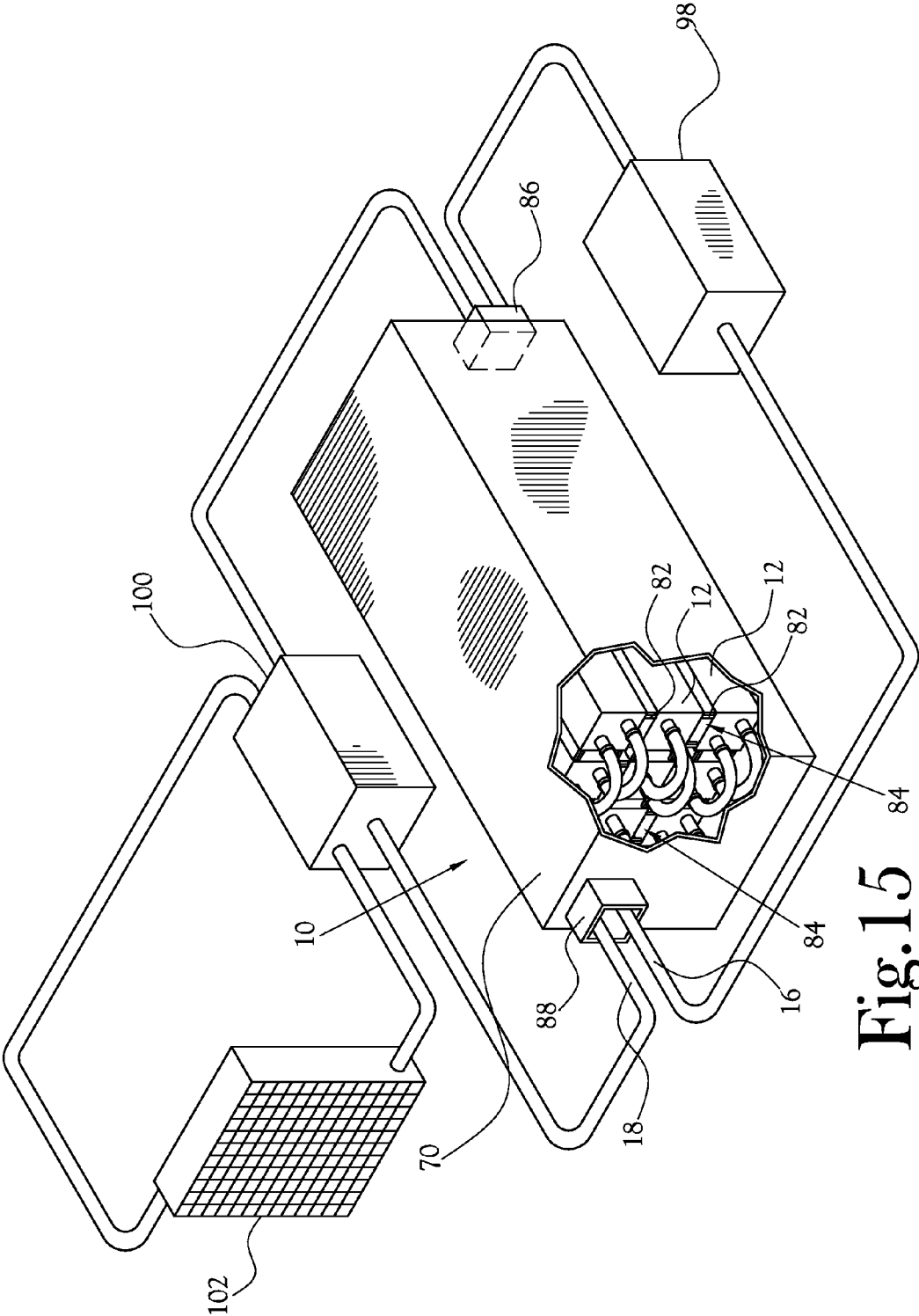

Fig. 15

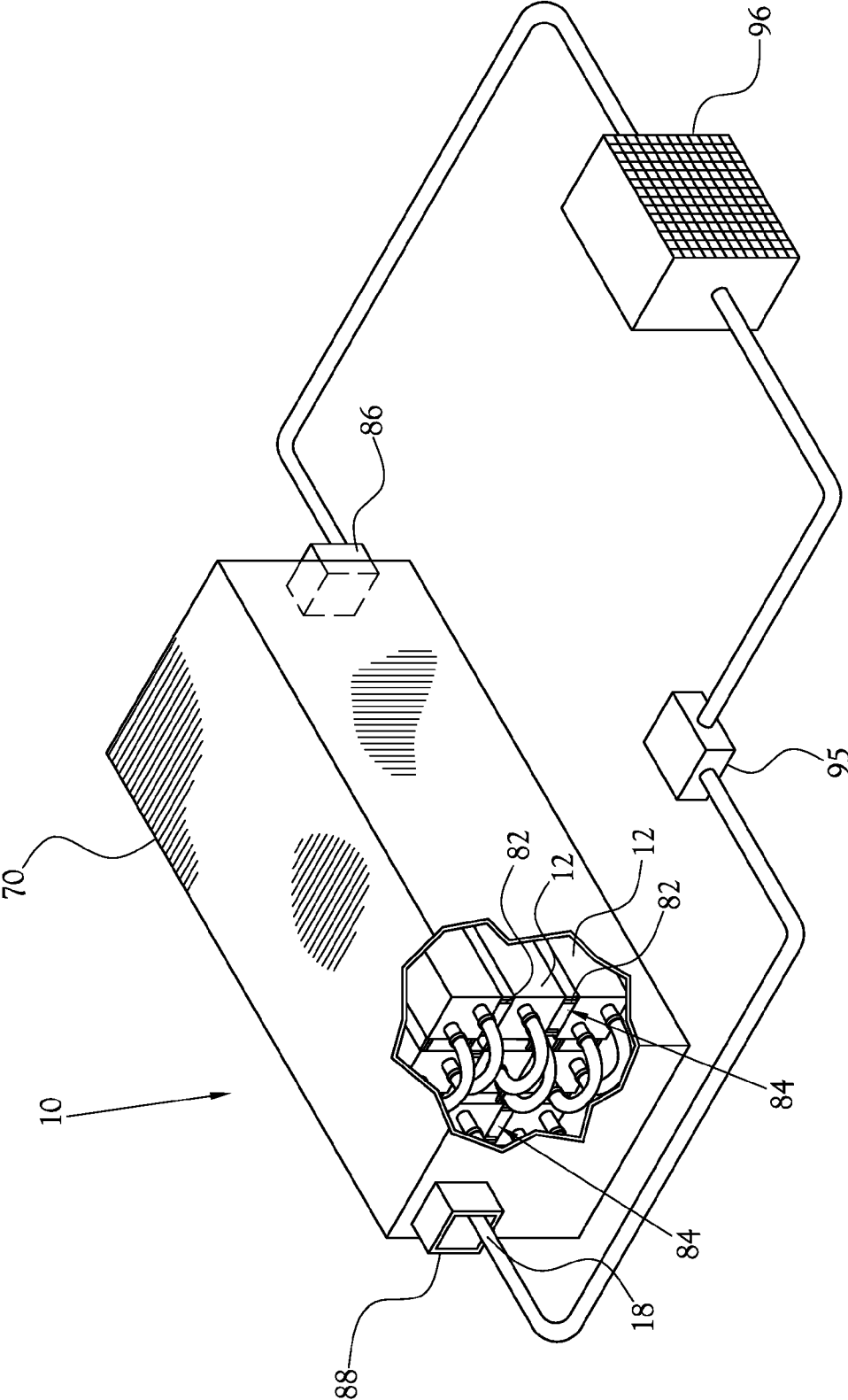

Fig. 16

**MODULAR THERMAL ENERGY
RETENTION AND TRANSFER SYSTEM**

CROSS-REFERENCE TO RELATED
APPLICATIONS

[0001] Not Applicable

STATEMENT REGARDING FEDERALLY
SPONSORED RESEARCH OR DEVELOPMENT

[0002] Not Applicable

BACKGROUND OF THE INVENTION

[0003] 1. Field of the Invention

[0004] This invention pertains to a modular system for collecting and/or generating and retaining thermal energy and for transferring the thermal energy to a usable fluid.

[0005] 2. Description of the Related Art

[0006] In the field of energy management, energy usage during peak periods generally drives the capital expenditures of energy production and imposes increased economic demand on consumable energy. It will be understood that a "peak period" is a time frame within which there is a usual and predictable spike in demand for electricity from a given electrical grid. In several applications, increased demand for consumable energy during peak periods often results in increased costs of energy production, and in certain applications, a shortage of available consumable energy. For example, in the use of thermal energy transfer technology for thermally conditioning ambient fluids such as water or air, it is generally more difficult and/or more costly to cool ambient fluids to a desirable temperature during particularly hot periods such as the summer, and conversely, it is often more difficult and/or more costly to heat ambient fluids during cold periods such as the winter, due in part to the increased differences between the ambient temperature during these periods and the desired temperature for the thermally conditioned fluids. Likewise, due to increased differences between ambient temperature and the desired temperature for thermally conditioned fluids, it is often more difficult and/or more costly to cool ambient fluids during the relative warmth of the day, and conversely, it is often more difficult to heat such ambient fluids during the relative cool of the night. By contrast, during time periods of non-peak energy usage, more economical thermal conditioning of ambient fluids is possible, thereby allowing a decreased economic demand for available consumable energy.

[0007] As worldwide energy consumption increases, it is desirable to develop more practical and economical methods for utilizing sources of energy which are intermittently more available during the time periods of non-peak energy usage. A number of thermal energy storage devices have been developed for gathering and storing energy in a thermal reservoir for later reuse. Typical of the art are those devices disclosed in the following U.S. patents:

Patent/App No.	Inventor(s)	Issue Date
4,010,731	Harrison	Mar. 8, 1977
4,203,489	Swiadek	May 20, 1980
4,234,782	Barbas et al.	Nov. 18, 1980

-continued

Patent/App No.	Inventor(s)	Issue Date
5,826,650	Keller et al.	Oct. 27, 1998
7,222,659	Levin	May 29, 2007

[0008] Of these patents, the '731 patent issued to Harrison discloses a bifurcated, liquid-impervious tank which is built into the ground. The tank of the Harrison patent contains rocks for use as a heat storage material surrounded by water for use as a heat transfer liquid. Water which is heated through a solar collector is circulated through the tank to transfer heat to the heat storage material. Thereafter, the cooled water is pumped back to the solar collector for reheating. A heat exchanger is mounted at the top of the tank for directing heat from the heat storage material to water and/or air to heat the water and/or air for domestic use.

[0009] In the '489 patent issued to Swiadek, a plurality of metal containers filled with liquid such as water are provided in a stacked configuration with spaced apart ducts defined therebetween. Hot air is passed through the ducts to transfer heat through the metal container walls to rapidly heat the liquid in each container. Thereafter, heat in the liquid is slowly and controllably released through a pair of thermally diffusing walls disposed on opposite outer portions of the container.

[0010] Barbas et al., in the '782 patent, disclose a central air heating system incorporating an alkaline metal or alkaline earth metal salt used as a heat storage material. The heat storage material is surrounded by an inner jacket, which is in turn surrounded by an outer jacket such that the inner jacket and outer jacket are spaced apart to define an air passage therebetween. An air flow control device is provided to selectively direct air flow through either the air space between the two jackets or both the air space between the two jackets and through the inner jacket containing the heat storage material.

[0011] The '650 patent issued to Keller et al. discloses a plurality of permeable concrete blocks forming an exterior wall of a building. The blocks cooperate to define channels through which air is circulated to heat or cool the blocks during non-peak usage hours.

[0012] In the '659 patent issued to Levin, a multistage tower having a system of flat, rigid containers is provided. Each container is filled with a phase change material adapted to store heat by inducing a phase change of the phase change material. Heat transfer to and from the phase change material is accomplished through a heat transfer fluid within the tower.

[0013] Several of the prior art devices are limited in their adaptability to the need for thermal energy storage devices of various sizes, shapes, and capacities. For example, the thermal energy storage devices disclosed in the '731 patent, the '782 patent, the '650 patent, and the '659 patent, as discussed above, each require that the device be constructed and permanently installed at the site of the intended usage of the device, thus limiting the ability to expand or reduce the size and/or capacity of the device following initial installation. Moreover, several of the prior art devices are limited in their ability to be used for collection, storage, and dispensation of thermal energy for use in heating and/or cooling both liquid and gas fluids. Consequently, a modular system for collecting and/or supplying and retaining thermal energy and for transferring the thermal energy to liquid and/or gas fluids is desired.

[0014] As worldwide demand for energy continues to increase, renewable sources of energy that do not depend on finite fuel sources are desirable. However, many known renewable sources of energy are intermittent and are therefore not always available coincidentally with the demand for energy. A particular concern is in the area of solar photovoltaic technology. In recent years, great advances have been made in the cost reduction and performance of photovoltaic energy generators. Several organizations throughout the world are currently devoting significant resources to developing photovoltaic technology with the goal of achieving “grid parity” of a given electrical infrastructure. Thus, there is a need for cost effective energy storage technology in order to store the energy delivered from the photovoltaic generators. As a percentage of total energy used in a typical home, electrical energy is relatively small. The majority of energy used by individuals in a typical home is thermal energy, such as energy used to heat water and warm air. Since photovoltaic systems deliver electrical energy during the day, when most electrical energy is consumed, there is less need to store electrical energy from photovoltaic panels for this purpose. However, in order to allow any significant portion of a home’s energy needs to be supplied by photovoltaic technology, a thermal energy storage system is needed which is capable of storing heat for use in the heating of water and warming of air in a home when solar energy is unavailable.

[0015] Another area of concern involves the charging of electric vehicles at residential homes. In order to recharge an electric vehicle in a reasonable time frame, a large amount of electrical energy must typically be transferred to the vehicle in a short time frame. In a situation in which several electric vehicles are charged simultaneously using a given electrical grid, a very high demand for electricity within the grid is produced. Some residential distribution networks are not designed to accommodate such large power flows. In such situations, the utility supplying the residential distribution network must typically meet these high power demands using another fuel source, such as for example natural gas fired turbines. Such natural gas fired turbines are typically extremely inefficient due to the amount of thermal energy wasted by the natural gas fired turbines due to the theoretical and practical limits imposed by the thermodynamic properties of the natural gas turbines. Thus, a cost effective thermal energy storage technology that can be coupled with a natural gas generator to conserve wasted energy of the natural gas generator is desirable.

BRIEF SUMMARY OF THE INVENTION

[0016] In accordance with the various features of the present invention there is provided a modular thermal energy transfer system for collecting and/or supplying thermal energy during a first time frame, for retaining at least a portion of the thermal energy until a second time frame, and for transferring at least a portion of the thermal energy to a usable fluid during the second time frame. The modular thermal energy transfer system includes generally a plurality of modular thermal units. Each modular thermal unit includes a thermal retainer which defines at least one through opening, and preferably, a first through opening and a second through opening. At least one pipe is disposed within the at least one opening. In one embodiment, a conditioning pipe is disposed within the first through opening and a usable fluid pipe is disposed within the second through opening. The conditioning pipe is adapted to carry a conditioning fluid therethrough

and to allow the transfer of thermal energy between the thermal retainer and the conditioning fluid. Likewise, the usable fluid pipe is adapted to carry a usable fluid therethrough and to allow the transfer of thermal energy between the thermal retainer and the usable fluid. In one embodiment, the conditioning pipe and cooperating usable fluid pipe of a given modular thermal unit are collectively defined by a single pipe.

[0017] The various thermal retainers of the modular thermal units are configured to be positionable proximate one another such that thermal energy is transferable between substantially adjacent thermal retainers. The conditioning pipes are in fluidic communication with one another, such that conditioning fluid is capable of passing sequentially through each of the conditioning pipes of the modular thermal energy transfer system, thereby allowing thermal exchange between the conditioning fluid and each of the thermal retainers. Likewise, the usable fluid pipes are in fluidic communication with one another, such that usable fluid is capable of passing sequentially through each of the usable fluid pipes of the modular thermal energy transfer system, thereby allowing thermal exchange between the usable fluid and each of the thermal retainers.

[0018] In some embodiments, a thermal generating member, such as an electrical heating element, is disposed within each thermal retainer. The thermal generating member provides thermal energy exchange between the thermal retainer and the thermal generating member to accomplish thermal conditioning of the thermal retainer.

BRIEF DESCRIPTION OF THE SEVERAL VIEWS OF THE DRAWINGS

[0019] The above-mentioned features of the invention will become more clearly understood from the following detailed description of the invention read together with the drawings in which:

[0020] FIG. 1 is a perspective view of one embodiment of the modular thermal energy transfer system of the present invention and depicting several features of the invention;

[0021] FIG. 2 is a perspective view showing a modular thermal unit of the modular thermal energy transfer system of FIG. 1;

[0022] FIG. 3 is a perspective view showing the modular thermal units of the modular thermal energy transfer system of FIG. 1;

[0023] FIG. 4 is a top view showing the conditioning pipes and the usable fluid pipes of the upper tier of modular thermal units of the modular thermal energy transfer system of FIG. 1;

[0024] FIG. 5 is a top view showing the conditioning pipes and the usable fluid pipes of the lower tier of modular thermal units of the modular thermal energy transfer system of FIG. 1;

[0025] FIG. 6 is a cross-sectional view of one embodiment of a modular thermal unit, depicting a schematic illustration of heat transfer between the thermal retainer and fluids within the pipes;

[0026] FIG. 7 is a cross-sectional view of another embodiment of a modular thermal unit, depicting a schematic illustration of heat transfer between the thermal retainer and fluids within the pipes;

[0027] FIG. 8 is a side view of the modular thermal energy transfer system of FIG. 1 which includes a schematic illustration of a fluid pump, thermal exchanger, usable fluid source, and user;

[0028] FIG. 9 is a side view of another embodiment of a modular thermal energy transfer system, showing a housing and insulation surrounding the modular thermal units;

[0029] FIG. 10a is a cross-sectional view of another embodiment of a modular thermal unit, depicting a schematic illustration of heat transfer between the thermal retainer and the thermal generating members;

[0030] FIG. 10b is a perspective view of another embodiment of a modular thermal unit, depicting a schematic illustration of a helically wound thermal generating member within a thermal retainer;

[0031] FIG. 11 is a side view of the modular thermal energy transfer system of FIG. 1 which includes a schematic illustration of a solar water heater, usable fluid source, and user;

[0032] FIG. 12 is another embodiment of the modular thermal energy transfer system including a schematic illustration of a solar water heater, usable fluid source, and user.

[0033] FIG. 13 is another embodiment of a modular thermal energy transfer system, showing a housing including a plurality of spacers configured between the modular thermal units;

[0034] FIG. 14 is a perspective view showing the embodiment of the modular thermal energy transfer system of FIG. 13, together with a simplified schematic illustration of one configuration of a thermal exchange system;

[0035] FIG. 15 is a perspective view showing the embodiment of the modular thermal energy transfer system of FIG. 13, together with a simplified schematic illustration of another configuration of a thermal exchange system;

[0036] FIG. 16 is a perspective view showing the embodiment of the modular thermal energy transfer system of FIG. 10b, together with a simplified schematic illustration of another configuration of a thermal exchange system.

DETAILED DESCRIPTION OF THE INVENTION

[0037] The present invention provides a modular thermal energy transfer system for collecting and/or supplying thermal energy during a first time frame, for retaining at least a portion of the thermal energy until a second time frame, and for transferring at least a portion of the thermal energy to a usable fluid during the second time frame. More specifically, the present invention provides a modular apparatus for transferring thermal energy between a first fluid and a medium, and/or supplying thermal energy and transferring the generated thermal energy to the medium, to create a temperature differential in the medium, maintaining the temperature differential in the medium, and applying the temperature differential to a second fluid to change the temperature in the second fluid.

[0038] A perspective view of one embodiment of the modular thermal energy transfer system constructed in accordance with the various features of the present invention is illustrated generally at 10 in FIG. 1. The modular thermal energy transfer system, or system 10, includes a plurality of thermal modules 12. Referring to FIG. 2, each thermal module 12 includes a thermal retainer 14, and at least one pipe for transferring a fluid through the thermal retainer 14 to allow transfer of thermal energy between the thermal retainer 14 and the at least one pipe. In the illustrated embodiment, a conditioning pipe 16 for transferring a conditioning fluid through the thermal retainer 14 during a first time frame, and a usable fluid pipe 18 for transferring usable fluid through the thermal retainer 14 during a second time frame, are provided. In the illustrated embodiment, the thermal retainer 14 is defined by

a substantially prismatic volume having a substantially elongated dimension 15, which is constructed of a material having a relatively high thermal mass as compared to the remainder of the system 10. For example, in one embodiment, the thermal retainer 14 is fabricated from a composite stone material such as concrete. In another embodiment, the thermal retainer 14 is fabricated from portland cement. In another embodiment, the thermal retainer 14 is fabricated from stone. Each thermal retainer 14 defines a pair of substantially parallel through openings 17a, 17b extending generally along the substantially elongated dimension 15 of the thermal retainer 14. A first through opening 17a is keyed to and carries the conditioning pipe 16 therein, and a second through opening 17b is keyed to and carries the usable fluid pipe 18 therein such that the longitudinal axes of the pipes 16, 18 are substantially parallel with the elongated dimension of the thermal retainer 14. The conditioning pipe 16 and the usable fluid pipe 18 are each dimensioned such that the pipes 16, 18 each extend at the length of the elongated dimension 15 of the thermal retainer 14. In the illustrated embodiment, the conditioning pipe 16 and the usable fluid pipe 18 each extend slightly beyond the thermal retainer 14 to allow for additional pipes to be connected to the conditioning pipe 16 and the usable fluid pipe 18 as will be discussed further below. The thermal retainer 14 maintains at least intimate contact with the conditioning pipe 16 and the usable fluid pipe 18 and, in certain more discreet embodiments, establishes a connection with each of the pipes 16, 18 to secure the conditioning pipe 16 and the usable fluid pipe 18 within the thermal retainer openings 17a, 17b. In one embodiment, the thermal retainer 14 establishes a frictional connection with each of the pipes 16, 18. In another embodiment, the pipes 16, 18 are bonded within the thermal retainer 14. In another embodiment, the thermal retainer 14 is fabricated from a cement material which is poured into a form having the pipes 16, 18 suspended therein, such that the cement material cures to form the thermal retainer 14 having the pipes 16, 18 carried therein. Those skilled in the art will recognize other suitable means for establishing a connection between the thermal retainer 14 and the pipes 16, 18, and such means may be used without departing from the spirit and scope of the present invention.

[0039] Both the conditioning pipe 16 and the usable fluid pipe 18 are adapted to conduct thermal energy between the thermal retainer 14 and fluid travelling through the pipes 16, 18. To this end, both the conditioning pipe 16 and the usable fluid pipe 18 are constructed from a thermally conductive material, such as copper or other thermally conductive metal. It will be understood by one of ordinary skill in the art that other thermally conductive materials exist which are suitable for fabrication of the conditioning pipe 16 and the usable fluid pipe 18, and such materials may be used without departing from the spirit and scope of the present invention. As will be further discussed below, the various conditioning pipes 16 of the system 10 cooperate to transfer a conditioning fluid 46 (see FIG. 6) through each of the thermal retainers 14 in order to conduct thermal energy between the conditioning fluid 46 and the thermal retainers 14 during a first time frame, thereby shifting the temperature of the thermal retainers 14 toward the temperature of the conditioning fluid 46.

[0040] Referring to FIGS. 2 and 3, the plurality of thermal modules 12 forming the modular thermal energy transfer system 10 are adapted to be positioned proximate one another, such that thermal energy may be conducted between substantially adjacent thermal retainers 14. In several

embodiments, the cross-section of each thermal module 12, as defined by the perpendicular of the elongated dimension 15, is shaped such that each thermal module 12 is stackable proximate an adjacent thermal module 12 with the elongated dimension of adjacent thermal modules 12 extending substantially parallel to one another. To this extent, in the illustrated embodiment, the system 10 includes nine (9) thermal modules 12, each having a thermal retainer 14 defining a rectangular prismatic volume. Each thermal module 12 is positioned in a substantially rectangular array with respect to adjacent thermal modules 12 such that each thermal module 12 maintains at least intimate contact with adjacent modules 12. In the illustrated embodiment, each thermal retainer 14 defines a right rectangular prism, and each thermal module 12 is positioned with the elongated dimension 15 of the thermal retainer 14 extending at the elongated dimension 15 of adjacent thermal retainers 14, such that the modular thermal energy transfer system 10 defines a block contour. In a preferred embodiment, a sufficient number of adjacent thermal retainers 14 are provided such that the modular thermal energy transfer system 10 defines a cube shape. However, it should be noted that the number of thermal modules 12 employed by the system 10 can vary without departing from the scope or spirit of the present invention. Additionally, it should be noted that the thermal retainers 14 can define numerous shapes, such as oblique prismatic shapes and non-prismatic shapes, or can have a cross-sectional shape other than that of a rectangle, without departing from the scope or spirit of the present invention.

[0041] FIG. 4 illustrates a top view of the system 10 of FIG. 1, showing various pipes 16, 18 of the top tier of thermal retainers 14 of the system 10, while FIG. 5 illustrates a top view of the system 10 of FIG. 1, showing various pipes 16, 18 of the bottom tier of thermal retainers 14 of the system 10. Referring to FIGS. 4 and 5, at least one of the conditioning pipes 16 of the plurality of thermal modules 12 is designated a conditioning intake pipe 20, and at least another of the conditioning pipes 16 of the plurality of thermal modules 12 is designated a conditioning outlet pipe 22. Each of the conditioning pipes 16 of the plurality of thermal modules 12 is in fluidic communication with another conditioning pipe 16 via a plurality of conditioning fluid joining pipes 24, such that there is uninterrupted fluidic communication between the conditioning intake pipe 20 and the conditioning outlet pipe 22 by way of the remainder of the conditioning pipes 16. In the illustrated embodiment, a conditioning fluid input 26 is in fluidic communication with a first end 28 of the conditioning intake pipe 20. A second end 30 of the conditioning intake pipe 20 is connected in fluidic communication with a first conditioning fluid joining pipe 24a, which is in turn connected in fluidic communication with a second end 32 of a first conditioning pipe 16a disposed within an adjacent thermal module 12. The first end 34 of the first conditioning pipe 16a is connected in fluidic communication with a second conditioning fluid joining pipe 24b, which is in turn connected in fluidic communication with the first end 36 of a second conditioning pipe 16b disposed within an adjacent thermal module 12. Each of the various conditioning pipes 16 are joined in fluidic communication with one another in like manner through similar conditioning fluid joining pipes 24 until ultimately, as shown in FIG. 5, a final conditioning fluid joining pipe 24x is provided to join a final conditioning pipe 16x in fluidic communication with a first end 38 of the conditioning outlet pipe 22. In the illustrated embodiment, a

second end 39 of the conditioning outlet pipe 22 is in fluidic communication with a conditioning fluid output 28. In this configuration, a conditioning fluid 46 is capable of passing from the conditioning fluid input 26 through the conditioning intake pipe 20 and sequentially through each of the conditioning pipes 16 and cooperating conditioning fluid joining pipes 24 before passing through the conditioning outlet pipe 22 to the conditioning fluid output 28.

[0042] Referring to FIGS. 6 and 7, in use of the system 10, a conditioning fluid 46 is passed through the various conditioning pipes 16 of the system 10 during a first time frame. The conditioning fluid 46 is a fluid having a temperature which is generally desirable for conditioning a usable fluid 48, but which is also different from the temperature of the ambient environment of the system 10. As the conditioning fluid 46 moves through the various conditioning pipes 16, conduction of thermal energy 50 through the conditioning pipes 16 occurs between the conditioning fluid 46 and the thermal retainers 14, thereby promoting a state of thermal equilibrium between the conditioning fluid 46 and the thermal retainers 14. As this thermal exchange approaches thermal equilibrium, the collective average temperature of the thermal retainers 14 is shifted toward the temperature of the conditioning fluid 46. In this manner, the average temperature of the thermal retainers 14 is altered from the temperature of the ambient environment of the system 10 toward approximately the temperature of the conditioning fluid 46 during the first time frame, thereby creating a thermal energy differential between the thermal retainers 14 and the ambient environment of the system 10. Likewise, as the conditioning fluid 46 passes through the conditioning pipes 16, the temperature of the conditioning fluid 46 is shifted toward the collective average temperature of the thermal retainers 14, thereby placing the conditioning fluid 46 in a spent condition. Thereafter, the spent conditioning fluid is transferred through the conditioning fluid outlet pipe 22 and out of the thermal modules 12.

[0043] It will be understood that the conditioning fluid 46 can be either a fluid hotter than the thermal retainer 14 or a fluid colder than the thermal retainer 14. For example, in the embodiment shown in FIG. 6, the conditioning fluid 46 is a heated fluid such that when the conditioning fluid 46 passes through the conditioning pipes 16 of the thermal modules 12, thermal energy 50 is transferred to and retained by the thermal retainers 14 from the conditioning fluid, thereby heating the thermal retainers 14. Similarly, in the embodiment of FIG. 7, the conditioning fluid 46 is a cooled fluid such that when the conditioning fluid passes through the conditioning pipes 16 of the thermal modules 12, thermal energy 50 is transferred from the thermal retainers 14 to the conditioning fluid 46, thereby cooling the thermal retainers 14. It will be understood that numerous substances exist which are suitable for use as the conditioning fluid 46, such as for example, water, anti-freeze, oil, and the like, and such substances may be used as such without departing from the spirit and scope of the present invention. The modular thermal energy transfer system 10 can utilize a liquid conditioning fluid 46 supplied from an independent source, such as, among other things, a water heater, a water refrigerator, refrigerant lines from a heat pump, heated or cooled liquid from a heat exchanger, or any hot or cold waste liquid from an independent apparatus. It should be noted that the conditioning fluid 46 can be supplied by independent sources other than those listed above without departing from the scope or spirit of the present invention. The system 10 can also utilize a liquid conditioning fluid 46

supplied from the system 10 itself, as will be discussed in further detail below. In another embodiment, the conditioning fluid is a gas, such as air. As with a liquid conditioning fluid 46, a gaseous conditioning fluid can be supplied by a source independent of the system 10 or can be supplied by the system 10. However, it will be understood that the amount of thermal energy 50 transferred by a gaseous conditioning fluid is governed by the temperature of the conditioning fluid and/or the pressure of the conditioning fluid within the conditioning pipe 16. To this extent, in one embodiment, the conditioning fluid comprises a compressed gas.

[0044] It will be understood by one skilled in the art that the amount of thermal energy 50 storable by the thermal retainers 14 per unit of volume of the thermal retainers 14 is generally governed by the thermal mass of the thermal retainers 14, as well as a unit of measurement of the various materials comprising the system 10 called the "storage figure of merit" or "SFM," which is the product of the material's specific heat and its density. In several embodiments, the specific heat of each of the thermal retainers 14 is less than the specific heat of the conditioning fluid 46, however, the material comprising the thermal retainers 14 is more dense than the conditioning fluid 46, such that the SFM of the thermal retainers 14 is similar to the SFM of the conditioning fluid 46. In one embodiment in which the conditioning fluid 46 is water having an SFM of approximately 62.4 BTU/(ft³ ° F.), the thermal retainers 14 are fabricated from a portland cement having a specific heat of approximately 0.37 BTU/(lb ° F.) and a density of approximately 170-190 lbs/ft³. In another embodiment, the thermal retainers 14 are fabricated from a material having a SFM greater than or equal to approximately 40 BTU/(ft³ ° F.), and more preferably, between 40-50 BTU/(ft³ ° F.). It will be understood that, because the system 10 is comprised of the plurality of thermal modules 12, the ultimate size of the system 10, and therefore the ultimate collective volume of the thermal retainers 14 and the ultimate thermal mass of the thermal retainers 14, is adjustable and governed by the number of thermal modules 12 employed. Accordingly, the size of the modular thermal energy transfer system 10 can be adjusted to cooperate with a given site, such as a site where a hot water heater and/or air conditioning unit would be kept. Additionally, because the system 10 is modular, the system 10 is adapted to be constructed on site such that the manufacture and transportation of the system 10 is eased.

[0045] The system 10 creates a thermal energy differential in the thermal retainers 14 by altering the average temperature of the thermal retainers 14 as discussed above within a first time frame. In several embodiments, the system 10 is adapted to supply conditioning fluid 46 to the conditioning pipes 16 such that the system 10 is autonomous. For example, in the illustrated embodiment of FIG. 8, the conditioning fluid input 26 and the conditioning fluid output 28 are in fluidic communication with a fluid pump 34 and a thermal exchanger 33. The fluid pump 34 is adapted to circulate conditioning fluid 46 between the thermal exchanger 33 and the conditioning pipes 16 of the thermal modules 12. In one embodiment, the flow rate of conditioning fluid 46 supplied by the fluid pump 34 is selectively adjustable. It will be understood that the flow rate of the conditioning fluid 46 through the conditioning pipes 16 generally governs the rate thermal energy 50 is transferred through the conditioning pipes 16 between the conditioning fluid 46 and the thermal retainers 14 within the system 10. For example, in a configuration in which the flow rate of the conditioning fluid 46 through the conditioning

pipes 16 is relatively low, the rate of conduction of thermal energy between the conditioning fluid 46 and the thermal retainers 14 is also relatively low. Conversely, in a configuration in which the flow rate of the conditioning fluid 46 is relatively high, the rate of thermal energy transfer between the conditioning fluid 46 and the thermal retainers 14 is increased. In a more discreet embodiment, the thermal exchanger 33 is integrally formed with the fluid pump 34, such that the fluid pump 34 is adapted to heat or cool the conditioning fluid 46 to further control the thermal energy differential created in the thermal retainers 14. While the above description explains the rate that thermal energy is transferred from the conditioning fluid to the thermal retainers is governed by the flow rate of the conditioning fluid, it will be recognized by those skilled in the art that heat transferred from the thermal retainers to the usable fluid is also governed by the flow rate of the usable fluid. A suitable means of flow rate adjustment could be applied to the usable fluid to control the rate of heat transfer from the thermal retainers to the usable fluid, and by extension the rate of heat transferred to an apparatus utilizing the usable fluid.

[0046] As discussed above with reference to FIGS. 6 and 7, the thermal retainers 14 substantially maintain a thermal energy differential until the second time frame, whereupon the thermal energy differential is applied to a usable fluid 48. During the second time frame, the various usable fluid pipes 18 of the modular thermal energy transfer system 10 cooperate to transfer usable fluid 48 through each of the thermal retainers 14 in order to conduct thermal energy 50 between the usable fluid 48 and the thermal retainers 14, thereby shifting the temperature of the usable fluid 48 toward the temperature of the thermal retainers 14. Referring again to FIGS. 4 and 5, at least one of the usable fluid pipes 18 of the plurality of thermal modules 12 is designated a usable fluid intake pipe 40 and at least another of the usable fluid pipes 18 is designated a usable fluid outlet pipe 42. Each of the usable fluid pipes 18 of the plurality of thermal modules 12 are in fluidic communication with one another via a plurality of usable fluid joining pipes 56, such that there is uninterrupted fluidic communication between the usable fluid intake 40 and the usable fluid outlet 42 by way of the remainder of the usable fluid pipes 18. A usable fluid input 44 is in fluidic communication with a first end 52 of the usable fluid intake pipe 40. A second end 54 of the usable fluid intake pipe 40 is connected in fluidic communication with a first usable fluid joining pipe 56a, which is in turn connected in fluidic communication with a second end 58 of a first usable fluid pipe 18a disposed within an adjacent thermal module 12. A first end 60 of the first usable fluid pipe 18a is connected in fluidic communication with a second usable fluid joining pipe 56b, which is in turn connected in fluidic communication with the first end 62 of a second usable fluid pipe 18b disposed within an adjacent thermal module 12. Each of the various usable fluid pipes 18 are joined in fluidic communication with one another in like manner through similar usable fluid joining pipes 56 until ultimately, as shown in FIG. 5, a final joining pipe 56x is provided to join a final usable fluid pipe 18x in fluidic communication with a first end 64 of the usable fluid outlet pipe 42. In the illustrated embodiment, a second end 66 of the usable fluid outlet pipe 42 is in fluidic communication with a usable fluid output 68. In this configuration, the usable fluid 48 is capable of passing through the usable fluid input 44 to the usable fluid intake pipe 40, sequentially through each

the usable fluid pipes 18 and cooperating usable fluid joining pipes 56, through the usable fluid outlet pipe 42, and through the usable fluid output 68.

[0047] Referring again to FIGS. 6 through 8, a usable fluid 48, such as potable water, is introduced to the modular thermal energy transfer system 10 from a usable fluid source 47 by way of the usable fluid input 44. As the usable fluid 48 passes through the thermal modules 12, thermal energy 50 is conducted between the thermal retainer 14 and the usable fluid 48 through the usable fluid pipes 18, thus altering the temperature of the usable fluid 48 from an initial temperature to a final temperature. As a result, the usable fluid 48 passing through the usable fluid output pipe 32 is thermally conditioned. Thereafter, the conditioned usable fluid is transferred through the usable fluid outlet pipe 42, through the usable fluid output 68, and ultimately, to a user 49. In the embodiment shown in FIG. 6, the usable fluid 48 is a cool fluid such that when the usable fluid 48 passes through the usable fluid pipes 18 of the thermal modules 12, thermal energy 50 is transferred from the heated thermal retainers 14 to the usable fluid 48, thereby heating the usable fluid 48. Conversely, in the embodiment of FIG. 7, the usable fluid 48 is a warm fluid such that when the usable fluid 48 passes through the usable fluid pipes 18 of the thermal modules 12, thermal energy 50 is transferred from the usable fluid 48 to the cooled thermal retainer 14, thereby cooling the usable fluid.

[0048] It will be understood that, in conditions in which the various fluids in the system 10 are not undergoing a phase change, the rate at which heat is transferred between the various fluids in the system 10 and the thermal retainers 14, represented by dq/dt is estimated by the following equation:

$$\frac{dq}{dt} = \left[(T_{ic} - T_{if}) \left(\frac{dm}{dt} \right) (C_{pf}) \right] - \left[\frac{\left((T_{ic} - T_{if}) \left(\frac{dm}{dt} \right) (C_{pf}) \right)^2}{(A)(h) + \left(\frac{dm}{dt} \right) (C_{pf})} \right] e^{\left[\frac{\left(\frac{dm}{dt} \right)^2 (C_{pf})^2}{(A)(h) + \left(\frac{dm}{dt} \right) (C_{pf})} - \left(\frac{dm}{dt} \right) (C_{pf}) \right] \left(\frac{1}{M_c} \right) (C_{pc})}$$

[0049] whereby, T_{ic} represents the initial temperature of the thermal retainers 14, T_{if} represents the initial temperature of the fluid upon entering the system 10,

$$\frac{dm}{dt}$$

represents the flow rate of the fluid through the thermal modules 12, C_{pf} represents the specific heat of the fluid, C_{pc} represents the specific heat of the thermal retainers, h represents the thermal energy transfer coefficient, A represents the surface area of the piping through which the fluid flows, and M_c represents the mass of the thermal retainers 14. Thus, the final temperature of the fluid T_{uf} upon exiting the system 10 is estimated by the following equation:

$$T_{uf} = \frac{\frac{dq}{dt}}{\left(\frac{dm}{dt} \right) (C_{pf})} + T_{if}$$

[0050] Referring now to FIG. 9, in one embodiment the system 10 includes an exterior housing 70 substantially enclosing the thermal modules 12 and the various joining pipes 24. The housing 70 serves to protect the thermal modules 12 and the various joining pipes 24, 56 from environmental elements, and also serves to limit thermal energy exchange between the various components of the system 10 and the ambient environment, thereby improving the ability of the thermal retainers 14 to maintain the thermal energy differential imparted to them by the conditioning fluid 46. In one embodiment, the housing 70 is manufactured from a thermally insulative material, such as wood, fiberglass, or other such insulative material. In the illustrated embodiment, insulation 72, such as fiberglass insulation of the type commonly used in building insulation, is disposed within the housing 70 between the housing 70 and the thermal modules 12 to further insulate the thermal retainers 14 against thermal energy transfer between the system 10 and the ambient environment, thereby further improving the ability of the thermal retainers 14 to maintain a thermal energy differential with the ambient environment.

[0051] In the embodiments of FIGS. 10a and 10b, a thermal energy supply is provided to the thermal modules 12 such that the thermal modules 12 gather thermal energy from sources within the system 10 other than the conditioning fluid 46. In the embodiments of FIGS. 10a and 10b, at least one thermal generating member 23 is provided in thermal communication with each thermal retainer 14. Each thermal generating member 23 is configured to provide thermal energy to a cooperating thermal retainer 14. In the illustrated embodiment of FIG. 10a, each thermal generating member 23 is defined by a length of copper wire carried within a cooperating thermal retainer 14 and extending along the length of the thermal retainer 14. In this embodiment, each of the thermal generating members 23 is adapted to be placed in electrical communication with an electrical power source (not shown). For example, in the embodiment of FIG. 10a, two thermal generating members 23 are provided. In this embodiment, one thermal generating member 23 is adapted to be placed in electrical communication with a photovoltaic electricity generator, while the other thermal generating member 23 is adapted to be placed in electrical communication with a standard residential electric grid. The electrical power source is configured to supply electric current to each of the thermal generating members 23, whereupon the electrical resistance of the copper wires to the electric current results in conversion of electric current to thermal energy. In this way, the thermal generating members 23 act to supply thermal energy to the thermal retainers 14. In a preferred embodiment, the thermal generating members 23 exhibit a greater electrical resistance than the apparatus connecting the thermal generating member 23 to each other and to the power source, such that the portions of the electrical circuit between the power source and the thermal retainer 14 generate less thermal energy than the portions of the thermal generating members 23 located within the thermal retainer 14.

[0052] In the embodiment of FIG. 10b, a plurality of usable fluid pipes 18 are provided for each thermal retainer 14. In this embodiment, a single thermal generating member 23 is provided, with a portion of the thermal generating member 23 extending through the thermal retainer 14 substantially parallel to the usable fluid pipes 18, and another portion of the thermal generating member 23 extending along the thermal retainer in a helical shape along the parallel portion of the thermal generating member 23.

[0053] It will be understood that the system 10 of the present invention may be placed in any of several configurations employing various components for collecting, generating and/or transferring thermal energy to allow the system 10 to collect and/or generate thermal energy during a first time frame, to retain at least a portion of the thermal energy until a second time frame, and to transferring at least a portion of the thermal energy to a usable fluid during the second time frame, as discussed above. By way of example, FIG. 11 illustrates one application of one embodiment of the system 10 of the present invention. In the embodiment of FIG. 11, the usable fluid 48 is potable water from a potable water source 76, and the usable fluid output pipe 42 serves as a potable water supply for a user 49, such as for example, a residence. The conditioning fluid 46 is heated water, such as water which has been heated in a solar water heater 78. The solar water heater 78 is configured to heat water and to transfer the heated water through the conditioning fluid pipes 18 to condition the thermal retainers 14 as discussed above. In one application, the system 10 is adapted to gather thermal energy from heated water produced by the solar water heater 78 during a non-peak period for a given electrical grid and to transfer at least a portion of the gathered thermal energy to the potable water during a peak period without drawing additional electricity from the electrical grid during the peak period.

[0054] FIG. 12 illustrates another application of one embodiment of the system 10. As shown in FIG. 12, a solar water heater 78 is provided which is adapted to heat both the usable fluid 46 and the conditioning fluid 48 such that solar generated thermal energy is transferred to the thermal retainers 14 of the system 10 by both the usable fluid 46 and the conditioning fluid 48 during a first time period, such as a period of abundantly available solar energy. During a second time period, such as a period when the solar water heater 78 is not exposed to abundant solar energy, such as during the night or when the sky is overcast, the system 10 provides thermal energy stored within the thermal retainers 14 to the usable fluid 48 in accordance with the above discussion. Thus, the system 10 is adapted to shift energy demand from a system using solar energy to heat water from a peak period to a non-peak period. Because the system 10 gathers the thermal energy during a first time frame, such as a non-peak period, and transfers the thermal energy to the usable fluid 48 during the second time frame, such as a peak period, the system 10 reduces the burden of energy demand during the peak period, thereby reducing cost for an energy consumer implementing the system 10.

[0055] In other embodiments, the system 10 is adapted to shift demand for electricity to cool air during a peak period. In one embodiment, the usable fluid is air which is circulated throughout a structure, such as a residence, while the conditioning fluid is cool water, such as cool potable water from a municipal water supply. As the cool potable water is directed through the conditioning pipes during a non-peak period for a given electrical grid, thermal energy transfers from the thermal retainers 14 to the potable water, thereby cooling the thermal retainers 14 and at least partially warming the potable water during the non-peak period. It will be understood that the at least partially warmed potable water may be thereafter directed to an apparatus for additional warming, such as a water heater, whereby the at least partial warming of the potable water by the system 10 allows for more efficient warming of the potable water with less energy expended by the warming apparatus. Thereafter, during a peak period for electricity to cool air, the air from the structure is directed through the usable fluid pipes 18, whereupon thermal energy

transfers from the air to the cooled thermal retainers 14, thereby cooling the air without drawing additional electricity from the electrical grid during the peak period. It should be noted that continual circulation of the conditioning fluid and the usable fluid through respective pipes 16, 18 of the system 10, and therefore continual thermal energy transfer between the conditioning fluid, the thermal retainers 14, and the usable fluid is contemplated.

[0056] FIG. 13 illustrates a perspective view of another embodiment of the modular thermal energy transfer system 10 in accordance with the various features of the present invention. In this embodiment, the plurality of thermal modules 12 is configured such that there is space between immediately adjacent modules 12 to allow for simultaneous conditioning of a usable fluid 48 and an ambient fluid, such as air. As shown in FIG. 13, a plurality of spacers 82 is provided, with at least one spacer 82 positioned between each of the thermal modules 12 such that the thermal modules 12 and the spacers 82 define at least one passageway 84 sufficient for air to pass therethrough. Unconditioned air is drawn through the at least one passageway 84 by a fan, pump, or other means readily known in the art. Because each passageway 84 is at least partially defined by the thermal retainers 14, the thermal energy retained by the thermal retainers 14 is dissipated into each passageway 84 such that air within each passageway is conditioned as it moves through the at least one passageway 84. In the illustrated embodiment, the modular thermal energy transfer system 10 includes a housing 70 having an air inlet 88 and an air outlet 86. Unconditioned air is drawn from the air inlet 88, through the at least one passageway 84, and thereafter away from the system 10 by way of the air outlet 86. As the unconditioned air travels through the at least one passageway 84, at least a portion of the thermal energy 50 retained by the thermal retainers 14 is dissipated into passageway 84 such that air within the passageway 84 is conditioned. As a result, the air drawn from the system 10 at the air outlet 86 is conditioned. Although the illustrated embodiment shows the plurality of spacers 82 positioned throughout the thermal modules 12 of the system 10 so as to space apart the thermal modules 12 both vertically and horizontally, it should be noted that the spacers 82 can be arranged in numerous configurations proximate the thermal modules 12 to define the at least one passageway 84 without departing from the scope or spirit of the present invention. For example, in one embodiment, the thermal modules 12 are arranged in columns such that the at least one passageway 84 is defined between the columns.

[0057] FIG. 14 illustrates another application of one embodiment of the system 10. As shown in FIG. 14, a heat pump 90 is provided in fluid communication with the various conditioning pipes 16. The heat pump 90 serves to heat the conditioning fluid 46 circulating within the conditioning pipes 16, thereby transferring thermal energy to the thermal retainers 14 of the system 10 during a first time period, such as a period when solar generated electricity is available or when ample supply of electricity is available on an electrical grid to drive the heat pump 90. The usable fluid pipes 18 are in fluid communication with a heat delivery system 92, such as a radiant heat floor system, water source heat pump, or other known heat delivery system 92. During a second time period, such as when solar electricity is not available or when electricity from an electrical grid is in low supply, the thermal energy stored within the thermal retainers 14 is transferred to the heat delivery system 92 via the usable fluid 48. In the illustrated embodiment of FIG. 14, a pair of valves 94 is provided to divert flow of the conditioning fluid 46 provided by the heat pump 90 from the system 10 to a heat exchanger

96, such as a water-to-air heat exchanger of the type commonly used in residential heating systems. In another application, the heat pump 90 supplies air conditioning for the residence by means of the heat exchanger 96.

[0058] Another application of one embodiment of the system 10 is illustrated in FIG. 15. In this embodiment, an air-to-water heat pump 98 is provided fluid communication with the various conditioning pipes 16. The air-to-water heat pump 98 is provided to selectively add or remove thermal energy to the conditioning fluid 46 circulating between the air-to-water heat pump 98 and the conditioning pipes 16 of the modular thermal units 12. The usable fluid pipes 18 of the system 10 are in fluid communication with a water-to-water heat pump 100, which is in turn in fluid communication with a water-to-air heat exchanger 102 of the type commonly used in residential heating and air-conditioning systems. During periods of warm ambient temperature, the air-to-water heat pump 98 is capable of being configured to remove thermal energy from the conditioning fluid 46, thereby creating a relatively cool condition of the thermal retainers 14. During circulation of usable fluid 48 through the usable fluid pipes 18, the usable fluid 48 is cooled by the thermal retainers 14, thereby providing a source of cool fluid to the water-to-water heat pump 100. The water-to-air heat exchanger 102 is adapted to utilize the cool fluid circulated to the water-to-water heat pump 100 to cool air to be used in air-conditioning. Conversely, during periods of cool ambient temperature, the air-to-water heat pump 98 is capable of being configured to add thermal energy from the conditioning fluid 46, thereby creating a relatively warm condition of the thermal retainers 14. During circulation of usable fluid 48 through the usable fluid pipes 18, the usable fluid 48 is warmed by the thermal retainers 14, thereby providing a source of warm fluid to the water-to-water heat pump 100. The water-to-air heat exchanger 102 is adapted to utilize the warm fluid circulated to the water-to-water heat pump 100 to heat air to be used in atmospheric heating. It will be understood that, while a water-to-water heat pump 100 is depicted in the present embodiment, other means of utilizing the usable fluid, for instance, a water to air-heat pump, may be used without departing from the spirit and scope of the present invention.

[0059] It will be understood that, in certain applications, the conditioning pipes 16 become usable fluid pipes 18. For example, the thermal generating members 23 provide thermal energy during a first time frame for conditioning the thermal retainer 14 during the first time frame. Thereafter, both pipes 16, 18 are configured to carry a usable fluid 48 during a second time frame to condition the usable fluid 48 during the second time frame.

[0060] In the illustrated embodiment of FIG. 16, each of the various pipes 16, 18 in the system 10 is connected in fluid communication with one another and with a variable speed fluid pump 95. The thermal generating members 23 provide thermal energy to the thermal retainers 14. The variable speed fluid pump 95 circulates the usable fluid through the various pipes 16, 18 to condition the usable fluid before it is transferred to the heat exchanger 96. It will be recognized that a variable speed fluid pump is one of many methods for controlling the flow rate through the various pipes 16, 18 and that any suitable means of flow regulation may be employed without departing from the spirit and scope of the present invention.

[0061] It will be understood that, by utilizing the embodiment of FIG. 16 for storing heat for later use, certain limitations of prior art air-to-air heat pumps are overcome. In a standard home heat pump installation, the heat pump is sized to the home's cooling load. The theoretical coefficient of

performance ("COP") of a heat pump is a function of the absolute temperature of the evaporator and condenser coils. Thus, with air temperatures of approximately 40° F., a typical air-to-air heat pump exhibits a COP of approximately 3.5, and serves as an effective heating apparatus. However, certain prior art heat pumps are incapable of delivering an adequate supply of heat to the home when ambient air temperatures drop significantly below 40° F. In such a situation, the prior art heat pump must rely on some form of auxiliary heat, typically in the form of electrical resistance heaters. Such operation of electrical resistance heaters in numerous homes in a given region creates undesirable peaks on the electrical distribution system during the time period in which ambient air temperatures are significantly below 40° F. However, the system 10 as shown in FIG. 16 serves to limit undesirable peaks on a given electrical distribution system by drawing electrical energy from the grid during periods of low demand through the thermal generating members 23 to condition the thermal retainers 14 during times of low electrical demand. The system 10 provides only the supplemental heat that is necessary due to its ability to control the rate at which heat is transferred from the thermal retainers 14 to the usable fluid. By controlling the flow rate of usable fluid through the system 10 and thereby the flow rate of fluid through the heat exchanger 96, the limits in the amount of heat that is deliverable by a prior art heat pump is supplemented by thermal energy supplied to the air by the heat exchanger 96. While FIG. 16 depicts the thermal energy storage system providing supplemental heat for the air-to-air heat pump, those skilled in the art will recognize that the system 10 may be used to provide all the heat requirements of a residence in the absence of a heat pump or other heating apparatus. Additionally, while a simplified embodiment is illustrated in FIG. 16, it will be readily apparent from the previous descriptions of the various embodiments of the invention that a second usable pipe may be employed to provide hot water for the residence.

[0062] From the foregoing description, those skilled in the art will recognize that a modular thermal energy transfer system for generating thermal energy during a first time frame, for retaining the thermal energy until a second time frame, and for transferring the thermal energy to a usable fluid during the second time frame offering advantages over the prior art has been provided. More specifically, the system is adapted to utilize a conditioning fluid to provide the thermal energy during a non-peak period, to retain the thermal energy within a concrete structure, and to transfer the thermal energy to the usable fluid during a peak period, a peak period being a period of time when the utilized electrical grid has an increased demand for delivering electricity. It will be understood that the system may be used in a variety of configurations, such as for example, as a substitute for typical ground loop components of a ground source heat pump. The modular configuration of the system allows for ease of access to the various system components for purposes of maintenance and/or replacement.

[0063] It will further be understood that the system may be used in a load-shifting capacity, wherein the thermal retainers of the system are heated during non-peak electrical usage hours, and where in the system provides an alternate source of thermal energy during periods of peak electrical usage. By moving heating demands to non-peak electrical usage times, a base load power plant is capable of supplying cool air to air conditioning equipment during warm periods and creating cool temperature differentials within the system for storage during cool periods. Conversely, utilizing the system, a base load power plant is capable of supplying electricity for warming air to heating equipment during cool periods and deliver-

ing energy to the system for storage during warm periods. Because the thermal energy dissipated in a fixed electrical resistance increases as a function of the square of the current passing through the fixed resistance, load shifting the electrical energy demand for heating purposes further reduces transmission losses and reduces the maximum current needed in a given electrical grid. Moreover, by storing heat for later use, the system allows a heat pump having a reduced heating capacity, and therefore a greater efficiency, to be employed for a given building's heating needs.

[0064] While the present invention has been illustrated by description of several embodiments and while the illustrative embodiments have been described in considerable detail, it is not the intention of the applicant to restrict or in any way limit the scope of the appended claims to such detail. Additional advantages and modifications will readily appear to those skilled in the art. The invention in its broader aspects is therefore not limited to the specific details, representative apparatus and methods, and illustrative examples shown and described. Accordingly, departures may be made from such details without departing from the spirit or scope of applicant's general inventive concept.

Having thus described the aforementioned invention, what is claimed is:

1. A modular thermal energy transfer system for transferring a thermal energy differential from a conditioning fluid, storing the thermal energy differential, and dissipating at least a portion of the thermal energy differential to thermally condition a usable fluid, said modular thermal energy transfer system comprising:

- a plurality of modular thermal units, each of said modular thermal units having:
 - a thermal retainer having a volume defining a first through opening and a second through opening;
 - a conditioning pipe disposed within said first through opening, said conditioning pipe being adapted to carry the conditioning fluid to transfer thermal energy between said thermal retainer and said conditioning fluid; and
 - a usable fluid pipe disposed within said second through opening, said usable fluid pipe being adapted to carry a usable fluid to transfer thermal energy between said thermal retainer and said usable fluid;

wherein each said thermal retainer is positionable proximate at least one other thermal retainer such that thermal energy is transferable between substantially adjacent thermal retainers, wherein each said conditioning pipe is in fluidic communication with at least one other conditioning pipe, and wherein each said usable fluid pipe is in fluidic communication with at least one other usable fluid pipe.

2. The modular thermal energy transfer system of claim 1, each said thermal retainer being fabricated from a material having a density greater than the density of the usable fluid and the conditioning fluid.

3. The modular thermal energy transfer system of claim 1, each said thermal retainer defining a substantially elongated dimension, each said first and second through openings being configured along said elongated dimension of said corresponding thermal retainer.

4. The modular thermal energy transfer system of claim 3, wherein each said thermal retainer is stackable adjacent at least one other thermal retainer.

5. The modular thermal energy transfer system of claim 4, each said thermal retainer defining a substantially elongated

rectangular prism, wherein each said thermal retainer is stackable adjacent at least one other thermal retainer along said elongated dimension to form a block configuration.

6. The modular thermal energy transfer system of claim 5, said modular thermal energy transfer system further comprising a substantially insulative housing, each of said plurality of modular thermal units being arranged in said block configuration within said housing.

7. The modular thermal energy transfer system of claim 1, each said conditioning pipe having a diameter sized to maintain at least intimate contact along an inner surface of said first through opening of said corresponding thermal retainer, each said usable fluid pipe having a diameter sized to maintain at least intimate contact along an inner surface of said second through opening of said corresponding thermal retainer.

8. The modular thermal energy transfer system of claim 7, each said conditioning pipe being cemented along an inner surface of said first through opening of said corresponding thermal retainer, each said usable fluid pipe being cemented along an inner surface of said second through opening of said corresponding thermal retainer.

9. The modular thermal energy transfer system of claim 1, each said modular thermal unit further comprising a thermal generating member disposed to maintain at least intimate contact with said thermal retainer, each said thermal generating member being configured to provide thermal energy to said cooperating thermal retainer.

10. The modular thermal energy transfer system of claim 1 wherein each said thermal retainer is fabricated from portland cement.

11. A modular thermal energy transfer system for transferring a thermal energy differential from a conditioning fluid, storing the thermal energy differential, and dissipating at least a portion of the thermal energy differential to thermally condition a usable fluid, said modular thermal energy transfer system comprising:

- a housing having a conditioning fluid input, a conditioning fluid output, a usable fluid input, and a usable fluid output;
- a plurality of modular thermal units disposed within said housing, each of said modular thermal units having:
 - a conditioning pipe adapted to carry a conditioning fluid;
 - a usable fluid pipe disposed substantially along said conditioning pipe, said usable fluid pipe being adapted to carry a usable fluid; and
 - a thermal retainer having a greater thermal mass than said conditioning pipe and said usable fluid pipe, said thermal retainer substantially surrounding said conditioning pipe and said usable fluid pipe, said conditioning pipe being adapted to transfer thermal energy between said thermal retainer and said conditioning fluid, said usable fluid pipe being adapted to transfer thermal energy between said thermal retainer and said usable fluid;

a plurality of first joining pipes, each of said conditioning pipes being joined to another of said conditioning pipes by at least one of said first joining pipes, and

a plurality of second joining pipes, each of said usable fluid pipes being joined to another of said usable fluid pipes by at least one of said second joining pipes;

wherein at least one of said conditioning pipes is in fluid communication with said conditioning fluid intake and at least one other of said conditioning pipes is in fluid communication with said conditioning fluid output, and

wherein at least one of said usable fluid pipes is in fluid communication with said usable fluid intake and at least one other of said usable fluid pipes is in fluid communication with said usable fluid output.

12. The modular thermal energy transfer system of claim 11 further including an insulation disposed between said housing and said plurality of modular thermal units, said insulation comprising a fiberglass material.

13. The modular thermal energy transfer system of claim 11, each said thermal retainer defining a substantially elongated dimension, each said conditioning pipe and said usable fluid pipe being configured along said elongated dimension of said corresponding thermal retainer.

14. The modular thermal energy transfer system of claim 13 wherein each said thermal retainer is fabricated from portland cement.

15. The modular thermal energy transfer system of claim 14, each said modular thermal unit further comprising a thermal generating member in thermal communication with said thermal retainer, each said thermal generating member being in electrical communication with an electrical power source, said electrical power source being configured to supply electric current to said thermal generating members to generate thermal energy within said thermal generating members.

16. The modular thermal energy transfer system of claim 15 further including a pump in fluid connection with said conditioning fluid input, said pump being configured to move conditioning fluid through said plurality of conditioning pipes.

17. The modular thermal energy transfer system of claim 16 wherein the rate of flow of conditioning fluid through said plurality of conditioning pipes is selectively adjustable, thereby regulating heat transfer to said modular thermal unit.

18. The modular thermal energy transfer system of claim 11, each said modular thermal unit further comprising a thermal generating member in thermal communication with said thermal retainer, each said thermal generating member being in electrical communication with an electrical power source, said electrical power source being configured to supply electric current to said thermal generating members to generate thermal energy within said thermal generating members.

19. The modular thermal energy transfer system of claim 18 further including a pump in fluid connection with said conditioning fluid input, said pump being configured to move conditioning fluid through said plurality of conditioning pipes.

20. The modular thermal energy transfer system of claim 19 wherein the rate of flow of conditioning fluid through said plurality of conditioning pipes is selectively adjustable.

21. The modular thermal energy transfer system of claim 20 further including a pump in fluid communication with said usable fluid input, said pump being configured to move usable fluid through said plurality of usable fluid pipes.

22. The modular thermal energy transfer system of claim 21 wherein the rate of flow of usable fluid through said plurality of usable pipes is selectively adjustable, thereby regulating heat transfer from said modular thermal unit.

23. A modular thermal energy transfer system for transferring a thermal energy differential from a fluid during a first time frame, storing the thermal energy differential, and dissipating at least a portion of the thermal energy differential to thermally condition a usable fluid during a second time frame, said modular thermal energy transfer system comprising:

a housing having at least one usable fluid input and at least one usable fluid output;

a plurality of modular thermal units disposed within said housing, each of said modular thermal units having:

a thermal retainer having a volume defining at least one through opening;

a usable fluid pipe disposed within said through opening, said usable fluid pipe being adapted to carry a usable fluid to transfer thermal energy between said thermal retainer and said usable fluid, said thermal retainer having a greater thermal mass than said usable fluid pipe, said thermal retainer substantially surrounding said usable fluid pipe, said usable fluid pipe being adapted to transfer thermal energy between said thermal retainer and said usable fluid pipe; and

a plurality of first joining pipes, each of said usable fluid pipes being joined to another of said usable fluid pipes by at least one of said first joining pipes;

wherein at least one of said usable fluid pipes is in fluid communication with a usable fluid intake and at least one other of said usable fluid pipes is in fluid communication with a usable fluid output, and wherein each said thermal retainer is positionable proximate to at least one other thermal retainer such that thermal energy is transferable between substantially adjacent thermal retainers, wherein each said pipe is in fluidic communication with at least one other pipe.

24. The modular thermal energy transfer system of claim 23 further including an insulation disposed between said housing and said plurality of modular thermal units.

25. The modular thermal energy transfer system of claim 24, each said thermal retainer defining a substantially elongated dimension, each said usable fluid pipe configured along said elongated dimension of said corresponding thermal retainer.

26. The modular thermal energy transfer system of claim 25, wherein each said thermal retainer is fabricated from portland cement.

27. The modular thermal energy transfer system of claim 26, each said modular thermal unit further comprising a thermal generating member in thermal communication with said thermal retainer, each said thermal generating member being in electrical communication with an electrical power source, said electrical power source being configured to supply electric current to said thermal generating members to generate thermal energy within said thermal generating members.

28. The modular thermal energy transfer system of claim 27, wherein the rate of flow of usable fluid through said plurality of usable fluid pipes is selectively adjustable, thereby regulating heat transfer from said modular thermal unit.

* * * * *