



(51) International Patent Classification:

H04N 5/247 (2006.01) *H04N 5/268* (2006.01)
G06F 17/30 (2006.01) *H04N 7/00* (2011.01)
G06K 9/20 (2006.01)

(72) Inventors: **ROKSETH, Christian**; Rytterveien 95, 4046 Hafslsfjord (NO). **GILJA, Stig Are**; Kvidalandsveien 16, 4335 Dirdal (NO).

(21) International Application Number:

PCT/NO2017/050170

(74) Agent: **ACAPO AS**; P.O. Box 1880 Nordnes, 5817 Bergen (NO).

(22) International Filing Date:

29 June 2017 (29.06.2017)

(81) Designated States (unless otherwise indicated, for every kind of national protection available): AE, AG, AL, AM, AO, AT, AU, AZ, BA, BB, BG, BH, BN, BR, BW, BY, BZ, CA, CH, CL, CN, CO, CR, CU, CZ, DE, DJ, DK, DM, DO, DZ, EC, EE, EG, ES, FI, GB, GD, GE, GH, GM, GT, HN, HR, HU, ID, IL, IN, IR, IS, JO, JP, KE, KG, KH, KN, KP, KR, KW, KZ, LA, LC, LK, LR, LS, LU, LY, MA, MD, ME, MG, MK, MN, MW, MX, MY, MZ, NA, NG, NI, NO, NZ, OM, PA, PE, PG, PH, PL, PT, QA, RO, RS, RU, RW, SA, SC, SD, SE, SG, SK, SL, SM, ST, SV, SY, TH, TJ, TM, TN, TR, TT, TZ, UA, UG, US, UZ, VC, VN, ZA, ZM, ZW.

(25) Filing Language:

English

(26) Publication Language:

English

(30) Priority Data:

20161098 01 July 2016 (01.07.2016) NO

(71) Applicant: **TEAMEYE AS** [NO/NO]; Rytterveien 95, 4046 Hafslsfjord (NO).

(54) Title: CAMERA SYSTEM FOR FILMING SPORTS VENUES

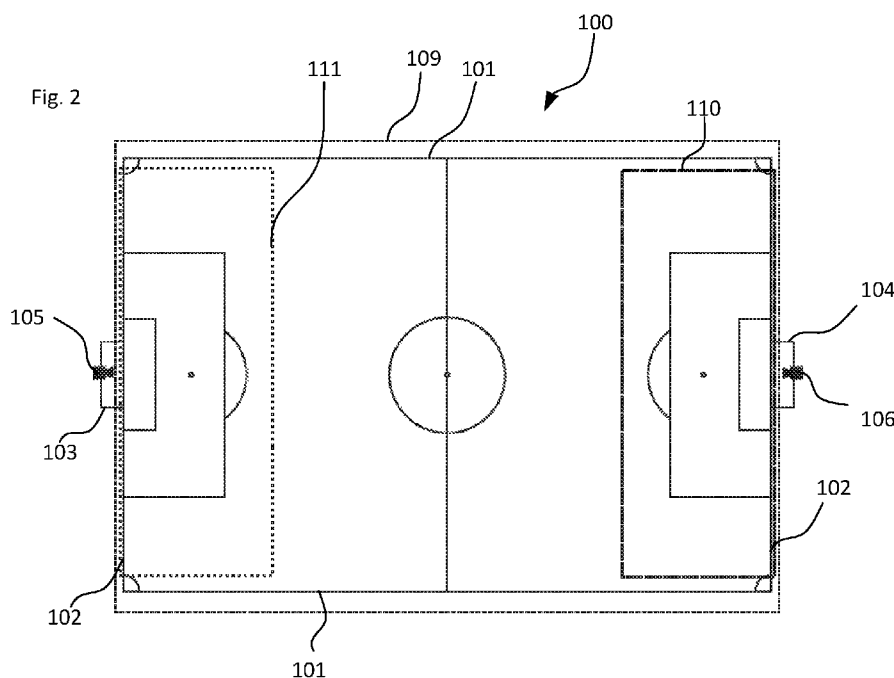

(57) Abstract: Camera system provided for filming a sports venue. The camera system (100) comprising a first and a second goal structure (103,104), a first digital image capture device (107) covering a first region (109), a second digital image capture device (108) covering a second region (110). The first region (109) comprises the second goal structure (104). The second region (110) is a sub region located substantially within the first region (109). The camera system further comprising processing means for processing received images captured from the first and second regions (109, 110). The processing means selects transmission of images captured from the first digital image capture device (107) when selecting an area within the first region (109) and selects transmission of images captured from the second digital image capture device (108) when selecting an area within the second region (110).



(84) Designated States (*unless otherwise indicated, for every kind of regional protection available*): ARIPO (BW, GH, GM, KE, LR, LS, MW, MZ, NA, RW, SD, SL, ST, SZ, TZ, UG, ZM, ZW), Eurasian (AM, AZ, BY, KG, KZ, RU, TJ, TM), European (AL, AT, BE, BG, CH, CY, CZ, DE, DK, EE, ES, FI, FR, GB, GR, HR, HU, IE, IS, IT, LT, LU, LV, MC, MK, MT, NL, NO, PL, PT, RO, RS, SE, SI, SK, SM, TR), OAPI (BF, BJ, CF, CG, CI, CM, GA, GN, GQ, GW, KM, ML, MR, NE, SN, TD, TG).

Published:

— *with international search report (Art. 21(3))*

CAMERA SYSTEM FOR FILMING SPORTS VENUES

5

Technical field

The present invention relates to a camera system for filming sports venues and a method for automatic capture of video sequences from a sports venue.

10 **Background**

Filming of sports venues is traditionally performed using expensive equipment mounted at a sports venue. The filming involves operators to aim the camera at interesting events during e.g. a soccer match. The editing of the film footage involves an operator.

15

US 2009/0284601 describes a system for automatically capturing an event of interest in a venue. The system creates a sideways panoramic view of the venue and performs selection of fields of interest from the panoramic view. The described system has several drawbacks in that the system is expensive and requires a large number of pre-mounted cameras.

20

The patent documents US20150264258, WO2013027064 and US20150297949 describe camera systems for filming a sports venue. The described systems have several drawbacks in that the systems are expensive and time consuming to install.

25

Objectives of the invention

It is appreciated that the known camera system for filming sports venues exhibit one or more problems in operation, for example:

- (a) costly to manufacture,
- 30 (b) non-intuitive use of the camera system,
- (c) complex and time consuming installation of the system,
- (d) low quality of recorded footages, and
- (e) low robustness in some operating conditions.

A camera system for filming a sports venue addressing one or more of the problems described in (a) to (e) above is therefore devised.

5 An objective of the disclosed invention is to provide an enhanced camera system for automatically generating film footage of a sports venue.

Another objective of the disclosed invention is to provide an enhanced camera system that is less costly to manufacture.

10 Yet another objective of the disclosed invention is to provide an enhanced camera system that provides an intuitive camera system.

Yet another objective of the disclosed invention is to provide an enhanced camera system that provides rapid and reliable installation of the camera system.

15

Yet another objective of the disclosed invention is to provide an enhanced camera system that provides high quality recordings of a sports venue.

Summary of invention

20 One or more of the objectives are met by a camera system for filming sports venues and a method for creating film footage of a sports venue according to the preamble and the characterising part of the independent claims. Further advantageous features are stated in the dependent claims.

25 According to a first aspect of the present invention, there is provided a camera system for filming a sports venue comprising a first and a second goal structure, wherein the first and second goal structures are located substantially opposite each other, wherein the camera system further comprises:

30 a first digital image capture device covering a first region of the sports venue,
a second digital image capture device covering a second region of the sports venue,

wherein the first region of the sports venue comprises the second goal structure,

wherein the second region of the sports venue is a sub region located substantially within the first region of the sports venue,

5 wherein the first and second digital image capture devices are attached to a first attachment structure.

The camera system further comprises processing means for processing received images captured from the first and second region of the sports venue,

10 wherein the processing means further comprises means for selecting a region of the sports venue for transmission,

wherein the processing means selects transmission of images captured from the first digital image capture device when selecting an area within the first region of the sports venue, and

15 wherein the processing means selects transmission of images captured from the second digital image capture device when selecting an area within the second region of the sports venue.

The invention has the advantage in requiring no human control of the camera system to film a sports venue.

20

It is appreciated that the term attachment structure encompasses goal structures, rods, light masts, portable tripods or other structure that the image capture devices may be attached to for filming the sports venue. The term attachment structure may also comprise a drone where the drone hovers over the sports venue. The image capture devices may also be a smartglasses where one or more image capture

25

devices are attached to a spectator or a player at the sports venue. The image capture device may also be a smartphone, where a spectator is capturing images of the sports venue holding and pointing the smartphone towards the sports venue.

30

Preferably, the first attachment structure is located along a first touchline. Such a location is advantageous in enabling measurement of the speed of longitudinal movement at a sports venue.

Preferably, the first attachment structure is located along a first goal line. Such a location is favourable in that there is little game activity along the first goal line.

5 Preferably, the first attachment structure is the first goal structure. Such a location is advantageous in utilizing an already existing structure for rapid mounting of the camera system.

10 Preferably, the camera system further comprises means for determining a location of at least one ball in at least one received image. Determination of the location of at least one ball enables tracking of the ball.

15 Preferably, the camera system further comprises means for determining a location of at least one player in at least one received image. Determination of location of at least one player enables tracking of the player.

It is appreciated that the term tracking encompasses determining locations of an object over time, possibly storing the previous locations of the object. Tracking may comprise estimating possible future locations of the object.

20 Preferably, the camera system further comprises means for downscaling images from a first image dimension to a second image dimension for adapting the image dimension to the recorded video dimension based on location in one received image of at least one object in a group comprising: a player and a ball. One advantage of this would be to enable zooming in on actions in the received image and presenting
25 the zoomed image.

30 Preferably, the camera system further comprises means for slow motion video creation where images are captured at a first framerate and recorded at a second framerate. An advantage with slow motion video creation is to enable capture of more details of rapid game play.

Preferably, the camera system further comprises:

a third digital image capture device covering a third region of the sports venue,

a fourth digital image capture device covering a fourth region of the sports venue,

5 wherein the third region of the sports venue comprises the first goal structure, wherein the fourth region of the sports venue is a sub region located substantially within the third region of the sports venue,

wherein the third and fourth digital image capture devices are attached to an attachment structure,

10 wherein the processing means selects transmission of images captured from the third digital image capture device when selecting an area within the third region of the sports venue, and

wherein the processing means selects transmission of images captured from the fourth digital image capture device when selecting an area within the fourth
15 region of the sports venue. One advantage of this arrangement is to enable capturing of events at a sports venue from multiple angles of view.

Preferably, the attachment structure is located opposite of the first attachment structure. Such location of the attachment structure enables filming of the sports
20 venue from an opposite direction.

Preferably, the attachment structure is the first attachment structure. Sharing a common attachment structure reduces the number of attachment structures.

25 Preferably, the attachment structure is the second goal structure. Using the second goal structure enables rapid attachment of the camera system.

Preferably, the camera system further comprising means for determining a location of at least one ball in at least one received image from the image capture devices on
30 the first goal structure and at least one received image from the image capture devices on the second goal structure. This is advantageous in enabling selection of images that correspond to the direction of play.

According to a second aspect of the present invention, there is provided a method for operating the processing means of the camera system wherein the processing means detects a ball on the sports venue and selects one of the at least one sub regions if the ball is located within said regions.

Preferably, the method wherein the processing means further detects when a ball crosses the half-way line and selects one of the at least one sub regions if the ball is located within said regions.

Preferably, the method wherein the processing means further detects when a ball crosses the half-way line and selects one of the at least one sub regions after an elapsed time or when the ball is at a certain distance from the half-way line.

According to a third aspect of the present invention, there is provided a method for operating the processing means of the camera system wherein the processing means detects a player controlling a ball on the sports venue and selects a selected region if the ball and the player are located within said regions.

Preferably, the method for operating the processing means further selects transmission of images from the regions with the ball and the player depending on a direction of playing the ball.

Preferably the direction of playing the ball is taken to be the direction of the ball relative to the player.

Preferably the direction of playing the ball is taken to be in the direction of the goal structure the player attempts to reach.

Preferably, the camera system further selects transmission of images from the regions with the ball using the digital image capture device located generally closest to the ball.

Preferably, the distance to the ball is determined by the vertical angle from the digital image capture devices to the ball.

Description of figures

- 5 The invention will now be described with the help of the enclosed figures, showing a camera system according to the present invention. The different parts of the figures are not necessarily in scale to each other, as the figures are merely for illustrating the invention.
- 10 The following description of an exemplary embodiment refers to the drawings, and the following detailed description is not meant or intended to limit the invention. Instead, the scope of the invention is defined by the appended claims.

Reference throughout the specification to “one embodiment” or “an embodiment”
15 means that a particular feature, structure, or characteristic described in connection with an embodiment is included in at least one embodiment of the subject matter disclosed. Thus, the appearance of the phrases “in one embodiment” or “in an embodiment” in various places throughout the specification is not necessarily referring to the same embodiment. Further, the particular features, structures or
20 characteristics may be combined in any suitable manner in one or more embodiments.

Exemplary embodiments of the invention will now be described, by way of example only, referring to the following diagrams in which:

- 25 Fig. 1 shows schematically a view of a preferred embodiment of a camera mounted at the crossbar of a goal;
Fig. 2 shows schematically a view of a first embodiment of the camera system;
Fig. 3 shows schematically an overview of the first embodiment of the camera system automatically switching between different regions of interest during a soccer
30 match;
Fig. 4 shows a schematic view of a soccer field captured by a wide angle image capturing device of the master camera mounted at a first goal;

Fig. 5 shows schematically a view of a cropped image from the view shown in Fig. 4;
 Fig. 6 shows a sequence of an operator recording and uploading video footage with the camera system;

5 Fig. 7 shows schematically a soccer field of the system shown in Fig. 2 where the angles of view of a first camera are indicated;

Fig. 8 shows schematically a second embodiment of a camera system for filming a sports venue;

Fig. 9 shows an embodiment of a camera system using a drone; and

10 Fig. 10 shows schematically multiple image capture devices transmitting images to a server.

Overview of components

Number	Description
100	Sports venue
101	Touchline
102	Goal line
103	First goal structure
104	Second goal structure
105	Master camera
106	Slave camera
107	First image capturing device
108	Second image capturing device
109	First and third region
110	Second region
111	Fourth region
112	Crossbar of goal structure
113	Soccer player
114	Football
115	Shaking of smartphone
116	Wide angle view from a master camera
117	Cropped image containing detected football

118	Smartphone
119	Server
120	Social media sites
130	Drone

Detailed description

The following description of the exemplary embodiment refers to the accompanying drawings. The same reference numbers in different drawings identify the same elements. The following detailed description does not limit the invention. Instead, the scope of the invention is defined by the appended claims. The different parts of the drawings are not necessarily in the same scale, as the figures are merely for illustrating embodiments of the invention.

10 The following description of exemplary embodiments refers to the drawings, and the following detailed description is not meant or intended to limit the invention. Instead, the scope of the invention is defined by the appended claims.

The sports venue is understood to include any field suitable to play a sport where there are at least one goal structure, like a soccer field, a basketball court, an ice hockey rink, a handball court or similar. The goal structure is understood to be a soccer goal, a basketball goal, an ice hockey goal or similar. Without limiting the scope of the invention the sports venue may also include tennis courts and volleyball courts. In general a sports venue may be understood to be a playing area for playing sports game comprising at least one ball and one player.

The sports venue is usually of rectangular shape where the outer perimeter is usually marked with white lines. On a soccer field the outer perimeter is marked with two usually parallel touchlines in the longitudinal direction. Two parallel goal lines, that are perpendicular to the touchlines, intersect the touchlines. The goal lines and touchlines form then the outer perimeter of a soccer field. In the scope of the invention the goal lines and the touchlines correspond to the base lines and the side lines in handball. In other sports the touch lines corresponds to sidewall of a

rectangular sports venue while the goal lines corresponds to the ends of a rectangular sports venue. The sports venue is usually separated in two equal sections in the longitudinal direction with marking. A soccer field is divided in two sections by a hall-way line. Other sports venues have similar lines to that separate the rectangular sports venue in to two sections. On a handball court and on an ice hockey rink the centre line corresponds to the half-way line. On a basket ball court the division line corresponds to the half-way line.

The invention relates to a novel camera system for filming sports venues. The camera system comprises at least a first and a second image capture device. The first image capture device covers a first region of the sports venue. The second image capture covers a second region of the sports venue. The second region is a sub region located substantially inside the first region of the sports venue. During a game the camera system transmits images captured by the first or the second image capture device to an operator. The selection of image to transmit may be based on the location of the ball inside the first region.

Fig. 1 is showing a camera 105, 106 mounted at the crossbar 112 of a goal structure 103,104. The camera has a first image capturing device 107 and a second image capturing device 108. The camera 105,106 is preferably mounted on the crossbar 112 of the goal using a quick grip mechanism (not shown). The quick grip mechanism is used to quickly attach the camera prior to a soccer match. When the match is over the camera can easily be detached from the crossbar. The first 107 and the second image capturing device 108 may preferably be mounted in a common unit. Mounting the first and the second image capturing device in a common unit would be advantageous to facilitate fast mounting of the two image capturing devices.

The camera 105,106 has a first image capturing device 107 with preferably a wide angle lens and a second image capturing device 108 with preferably a telephoto lens. A person skilled in the art would understand that wide angle lens has an angle of view that is larger than a telephoto lens. A telephoto lens is suitable for capturing

images of objects at long distance, while a wide angle lens is suitable for capturing images of objects at a shorter distance than a telephoto lens. A wide angle lens may have an angle view between 64 degrees and 84 degrees, optionally more than 84 degrees to capture wider views of the sports venue. The telephoto lens may have an
5 angle of view between 1 degree and 64 degrees, optionally between 10 and 30 degrees.

In other embodiments the camera 105, 106 may have more than two image capturing devices. One advantage of having multiple image capture devices in the
10 camera is that more advanced image captures can be performed like 360 degree filming or spherical filming. Having multiple image capture devices in the camera is also advantageous in that it enables easier mounting of the camera.

In other embodiments the camera 105, 106 comprises at least two first image capturing devices 107. One advantage of at least two first image capturing devices in
15 the camera 105, 106 is to provide a possibility to capture depth information.

In other embodiments the camera 105, 106 comprises at least two second image capturing devices 108. One advantage of at least two first image capturing devices
20 108 is the camera 105, 106 is to provide a possibility to capture depth information.

In other embodiments the camera 105, 106 comprises at least two first image capturing devices 107 and at least two second image capturing devices 108. One
25 advantage is to provide a possibility to capture depth information in both the telephoto and wide angle images.

In other embodiments the camera 105, 106 comprises depth sensing devices like infrared lasers, acoustic measurements or similar. This is to provide the possibility to calculate the distance from the camera to objects and thereby adjust the focus of the
30 image capturing devices.

In other embodiments the first and the second image capturing device 107,108 may be in separate units. Separate placement of the image capturing devices may allow for advanced image effects.

- 5 In some embodiments the arrangement of the image capturing devices of the camera may be any combination of vertical, horizontal placement while maintaining the ability to film towards the desired direction.

10 In some embodiments the quick grip mechanism is represented as a Velcro®, strips, screw fasteners or similar to fasten the camera to the goal structure. The quick grip mechanism is advantageous by providing ease of mounting of the camera.

15 In a preferred embodiment the cameras 105,106 are mounted on the crossbar of a goal structure. In other embodiments the cameras are located on the net, behind or above the goal structure, at a side post or somewhere in the proximity of a goal structure.

20 In Fig. 2 a preferred embodiment of the camera system is shown. The sports venue 100 is preferably a soccer field where the outer perimeter of the soccer field is defined by two parallel touchlines 101 and two parallel goal lines 102. The soccer field has a first 103 and a second 104 goal structure. The goal structures 103,104 are located opposite each other at opposite goal lines 102. A master camera 105 is mounted at the first goal structure 103. A slave camera 106 is mounted at the second goal structure 104.

25

The master camera 105 has a first image capturing device 107 with preferably a wide angle lens and a second image capturing device 108 with preferably a telephoto lens. The first image capturing device 107 and the second image capturing device 108 are arranged horizontally next to each and directed in the same direction towards the second goal structure 104. The master camera is mounted in such a way that it views the soccer field horizontally in the direction towards the second goal 30 104. The image capturing devices 107, 108 are in other embodiments arranged

vertically or diagonally next to each other while maintaining that the image capturing devices 107, 108 are directed substantially in the same direction.

5 The first image capturing device 107 is covering a first region 109 of the soccer field, where the first region 109 comprises an area defined by the soccer field. The second image capturing device 108 is covering a second region 110 of the soccer field. The second region 110 is a sub region located inside the first region 109 and the second region 109 is an area in front of the second goal 104.

10 Referring to Fig. 2 the slave camera 106 is mounted at the second goal structure 104. The slave camera 106 has a third image capture device 107 with preferably a wide angle lens and a fourth image capturing device 108 with preferably a telephoto lens. The third image capturing device 107 and the fourth image capturing device 108 are located horizontally next to each and directed in the same direction towards
15 the first goal structure 103. The slave camera 106 is mounted in such a way that it views the soccer field horizontally in the direction towards the first goal 103. The third image capturing device 107 covers a third region 109 of the soccer field, where the third region 109 comprises an area defined by the soccer field. The third region and the first region is preferably the same region. The fourth image capturing device 108
20 covers a fourth region 111 of the soccer field. The fourth region 111 is a sub region located inside the third region 109 and the fourth region 111 is covering an area in front of the first goal 103. The image capturing devices 107, 108 are in other embodiments arranged vertically, diagonally next to each other while maintaining that the image capturing devices 107, 108 are directed substantially in the same
25 direction.

In one embodiment the third region and the first region are different non-overlapping areas of the sports venue, this to simplify control of selection of regions. In an
embodiment the third and the first region are overlapping regions of the sports venue
30 to enable filming of an area from multiple directions.

In the scope of the invention the image capturing devices should be understood to be high resolution image capturing devices. Preferably the image capturing devices are digital image capturing devices. Preferably the image capturing devices have a capture resolution of 4K, e.g. 4096 x 2160 pixels. Without departing from the scope
5 of the invention, the image capturing devices may in other embodiments have higher resolution than 4K, e.g. 8K, 2160p, to capture more details. In some embodiments the image capturing devices may have a capture resolution of less than 4K, e.g. 1080p, 720p, to save cost on the image capturing devices or to adapt to an available bandwidth.

10

The aspect ratio of images captured by the image capturing devices is, for the scope of the invention, preferably an aspect ratio of 256:135. Without departing from the scope of the invention the aspect ratio may take any suitable range, like 4:3, 16:9. In some embodiments the aspect ratio is larger to provide the possibility to capture
15 widescreen images. In other embodiments the aspect ratio is smaller to provide the possibility to capture more narrow images. Without departing from the scope of the invention the image orientation of the captured images comprise any combination of landscape, portrait, and tilting.

20

In some embodiments the image capturing devices preferably have similar capture resolution to facilitate processing of the images. In other embodiments the image capturing devices have different capture resolution to possibly reduce the amount of captured image data.

25

In the preferred embodiment of the camera system the first and third image capturing device 107 and the second and fourth image capturing device 108, have a fixed depth of field. This would be advantageous to save cost of the image capturing devices.

30

In other embodiments the first and the second capturing devices 107, 108 have adjustable focus. Adjustable focus is advantageous to improve focusing on objects in the field of view.

In another embodiment the image capturing devices are combinations of image capturing devices with fixed depth of field and adjustable focus.

5 Still referring to Fig. 2, The master 105 and slave 106 cameras have processing means for simultaneously capturing video footage from both the image capturing devices and storing the captured video footage on an internal storage. The cameras preferably have wireless communication means for exchanging data between each other. A smartphone and the cameras form a wireless network where the
10 smartphone preferably provides Internet access for uploading video footage recorded by the cameras to the social networks like Facebook, YouTube, and Vimeo etc. Preferably the smartphone is used for configuration and control of the cameras through a software application. Communication between the cameras and the smartphone is performed via the wireless network. The smartphone application is
15 used to configure the cameras, start and stop recording of video, select video footage to upload to social networks. The cameras have processing means to perform object recognition within the images recorded by the image capturing devices. In the case where the camera is not in level, the camera may crop the captured image to make the cropped image levelled. The camera may have digital or
20 analogue image stabilization as this is advantageous for removing vibrations.

The image capturing devices have means to correct for tilting of captured images. Tilting of the image capturing devices may be due to unlevelled mounting of the image capturing devices. The correction for tilting of the captured images may be
25 corrected via one or more of the following: digital cropping of the captured images, adjustment of lens in image capturing device, rotating of image capture device or similar.

In other embodiments the cameras 105,106 comprise wireless means that enable
30 direct communication with the Internet, e.g. 4G, 5G, GSM, satellite or similar wireless communication. Such direct communication with the Internet enables the cameras to upload video footage directly to the Internet, e.g. Facebook, YouTube, etc. The

wireless means enables the possibility to receive and transmit instructions and information for operating the cameras or instructing other parts of the system.

5 Fig. 3 shows an overview how a system of a slave 106 and a master 105 camera automatically switch between different regions of interest during a soccer match. The master camera 105 is mounted at a first goal 103 and the slave camera 106 is mounted at a second goal 104. The master 105 and the slave 106 camera are directed towards the goal at the respective opposite side of a soccer field 100. The master 105 and the slave 106 camera each have two image capturing devices
10 preferably a first wide angle image capturing device and preferably a second telephoto capturing device.

During an exemplary soccer match a soccer player 113 and a football 114 move around the soccer field. The master 105 camera and slave 106 camera wirelessly
15 exchange information with each other. The master 105 camera and the slave 106 camera have processing means that determines via object recognition in the captured images the location of the player 113 and the football 114 on the soccer field 100. The master 105 camera and the slave 106 camera exchanges object recognition information about the location of players and the football on the soccer
20 field preferably via a wireless network. The master 105 camera and the slave 106 camera may cooperate on determining the location of the football during the soccer match.

The best view of the soccer match is determined based on the location of the football
25 114 on the soccer field 100 and which of the image capturing devices in the cameras that have best view of the football. Best view of the football may be the camera with the largest number of pixels covering containing the football, the camera that sees the largest area of the football or other feature of the football that is comparable between two or more captured images. Fig. 3 shows an exemplary sequence of
30 selecting the best view among the images capturing devices from the two cameras 103,104. In the course of the soccer match the player 113 moves the football 114

from a first location 1 to a seventh location 7 where the football has been kicked in to the second goal 104.

5 The processing means of the master camera determines which images capturing device at the master 105 camera or the slave 106 camera that has the best view of the location of the football. The processing means in the master 105 camera will create a video footage by selecting the best views of the football being moved from the first location 1 to the seventh location 7. This video footage may be stored on an internal storage of the master 105 camera for later retrieval.

10

The image capturing device with the best view is determined based on: highest image resolution at the location of the football, the direction the player is moving the football, the image capturing device with the largest field of view at the location of the football, the camera closest to the location of the football, the team that the player is
15 part of. The determination of the best view of the football location may be reconfigured during the soccer match.

At location 1 to 3 the master 105 camera has the best view of the player using the wide angle lens since these locations are closest to the wide angle image capturing
20 device of the master camera. At location 4 to 6 the best view is from the wide angle lens in the slave camera since these locations are closest in distance to the wide angle lens of the slave camera. The final scoring at location 7 has the best from the master camera using the telephoto lens since this has the highest resolution at the goal area of the soccer field. The cameras continuously store the captured images
25 from the respective image capturing devices on an internal storage for later editing.

In other embodiments the processing means detects when the ball is crossing the half-way line and determines which image capturing device that has the best view. Changes in which image capturing device that has the best view is preferably done
30 after a certain elapsed time after the ball has crossed the half-way line. It is advantageous to let some time elapse after the ball has crossed the half-way line to handle the case where the game play makes the ball crosses the half-way line many

times in a short time period, this to reduce the number of switching between image capturing devices. Rapid changes between the image capturing devices in the recorded footage may give low quality video footage. The elapsed time after the ball has crossed the half-way line may be preferably 5 seconds. Optionally the elapsed time may be less than 5 seconds where the gameplay is rapidly changing. In cases of slow game play the elapsed time may be more than 5 seconds to reduce the switching between image capturing devices. To avoid rapid switching between the image capturing devices a rule based system may be used where rapid switching between image capturing devices are avoided.

10

In other embodiments the best view is determined by the processing means to be when the ball is crossing the half-way line and where the ball has moved a certain distance away from the half-way line. This to handle the case where the game play makes the ball crosses the half-way line many times within a distance shorter than a certain distance from the half-way line. This to reduce the number of switching between image capturing devices. Rapid changes between the image capturing devices in the recorded footage may be confusing, disturbing and considered of being of low quality. Preferably the distance is 5 meters to prevent unwanted switching between the image capturing devices. Optionally the distance is less than 5 meters to allow rapid switching between the image capturing devices. The distance is less preferably more than 5 meters to prevent rapid switching between the image capturing devices.

15

20

25

In other embodiments a split screen solution may be used in the video footage. A split screen presentation in the video footage where two or more separate images are displayed. Split screen may be enabled when rapid switching between image capturing devices is detected. One advantage is that rapid switching of the image capturing devices is avoided.

30

Fig. 4 shows an image of a soccer field captured by the wide angle image capturing device of the master 105 camera mounted at the first goal 103. The images captured by the image capturing device may have a higher image resolution than what is

presented to a controlling smartphone or is uploaded to the Internet. The camera performs object recognition in the images captured by the image capturing device to determine the location of the football 114 in the captured images. The camera performs cropping in the captured image to create a cropped image 117 containing the football and surrounding players. During a soccer match the location of the football changes and the cropped selection in the captured image will follow the movement of the football.

In a preferred embodiment the image capturing devices capture images at preferably 4K resolution and the cropped images preferably have an image resolution of 1080p. In some embodiments the cropped images have lower resolution than 1080p to reduce storage requirements. In other embodiments the cropped images have higher resolution than 1080p to improve image quality.

Fig.5 shows a view of the cropped image 117 from the view shown in Fig. 4. In the same manner pan image sequences are created by selecting an area within the captured image 116. The system is configured to perform object recognition of soccer players 113 and determine the location of each individual player in the captured images. During a soccer match each player normally wears a team shirt having certain colours and patterns. At the soccer match two soccer teams will have different uniforms. The uniform of each player is marked with a different number.

To determine the location of each individual soccer player the system recognizes the colour of the team shirts and recognizes the number and name on the shirt. The system is configured with information regarding the names of the players of the teams and the corresponding number marked on the team shirt. The camera continuously determines the location of the football and the location of the players in the captured images. The information regarding the location of the football and the location of the players in the captured images may be stored in a memory device in the camera together with the corresponding captured image. For each captured image there is stored information regarding which players are present in the captured image.

In some embodiments the creating of pan sequences are preferably controlled by the camera. In other embodiments instructions for creating pan sequences are initiated via a smartphone application, this provides the possibility to create pan sequences
5 on demand.

In some embodiments the camera system recognizes players and objects on the soccer field by using object recognition. Players and objects are recognized by any combination of colour, patterns, text, markings, etc.
10

Fig. 6 shows a sequence of an operator recording and uploading video footage with the camera system. Prior to a soccer match preferably a camera is mounted at each goal. One of the two cameras is assigned the task as master and the other is assigned as slave. The assignment of slave and master camera is preferably done at
15 manufacturing. In less preferred embodiments the master and slave assignment of the cameras is done using a switch on the camera, configuration via a smartphone application, or automatically via object recognition of objects on the soccer field. Automatic assignment of master camera may be performed via object recognition. This is performed by the camera upon mounting of a first camera at the first goal, the
20 first camera detects the opposite goal and detects whether a second camera is mounted at the second goal. In the case where the first camera detects the second camera at the second goal the first camera is assigned as slave camera. In the case where the first camera does not detect a second camera at the second goal, the first camera is assigned as master camera. One advantage of this automatic master
25 assignment is simplified use of the system.

In the scope of the invention when referring to master or slave camera 105, 106 it should be understood that this may be interpreted as meaning that the master camera has functionality to coordinate capturing of images from multiple cameras. It
30 would be advantageous to have a single master camera coordinating one or more slave cameras to simplify the coordinating.

In some embodiments there is only be a single camera that is assigned as master camera. This would provide simple and cost effective system.

5 In other embodiments coordinating of multiple cameras is performed in a distributed fashion where the cameras perform decisions based on voting. This would be advantageous for providing a robust coordinating system, where failure of the master camera will not render the system non-usable.

10 In some embodiments there are two or more slave cameras 106. This would be advantageous to provide possibility to film the sports venue from multiple angles.

In other embodiments the coordinating functionality of the master camera is provided by a separate unit (computer, wireless access point, smartphone). This would be advantageous to reduce the complexity of the cameras.

15

In other embodiments the selection of the master camera is performed automatically by assigning the master camera role to the first camera that is powered up. This will provide a simplified use of the system.

20 Referring to Fig. 6 the cameras and a smartphone 118 are configured to communicate with each other via a wireless network. The smartphone 118 is provided with an application that controls the cameras and uploads video footage to a server 119 connected to the Internet. The operator enables the camera system with the smartphone 118. The camera system starts performing object recognition in
25 the images captured by the image capturing devices to determine the location of the football and to locate the players. During a match the cameras 105,106 track the football and the players and creates a video footage with selecting images from the image capturing device that has the best view of the location of the football. The images captured by the image capturing devices in the cameras 105,106 may be
30 stored on a storage device in the cameras. These stored images may be later used for offline editing of the soccer match. Preferably the cameras upload video footages automatically with the highlights from a completed match. The smartphone

application may provide possibilities for editing video footages for creating of video footages of the highlights.

In addition the cameras may have means to create slow motion footages of highlights on the soccer field. In some embodiments the camera system has means
5 to create visual effects in the recorded video footages. The visual effects may comprise effects like: slow motion, visual indications of highlights, overlay text, arrows, music, and colours.

Highlights in a soccer match may comprise events like: scorings, penalty kicks,
10 injuries of players, tackles, keeper saving the ball and offside.

When the operator sees an event like a scoring or other highlight during the soccer match, the smartphone 118 is shaken 115 to instruct the master camera 105 that video footage should be created. The master camera 105 may then present the
15 video footage to the smartphone 118. The video footage comprises a video sequence of the scoring and some seconds prior and after the instruction was sent by the smartphone 118. The instruction of the event may be performed by actions comprising shaking the smartphone for a specific duration, tapping the phone, detection of applause or cheers by the audience, automatically detection of goal
20 scoring or other highlights. The master camera 105 may automatically trigger creation of the video footage based on automatic detection of highlights. The camera may upload the video footage to a server 119. The server may be have access control to only permit specific users access like trainers, parents, family or similar.

25 The application on the smartphone may then upload the video footage to the server 119. The uploaded video footage may comprise information regarding which players are present in the video footage. This information may be used to tag video footages with the names of the players in the video footage. The system may also be configured to live stream content from the cameras via the smartphone to a
30 livestreaming service on the Internet. When the match is over the operator may review the statistics of the soccer match on the smartphone 118 and share information and video footage on social media sites 120 like Facebook.

In the preferred embodiment the camera system, when enabled and mounted, continuously captures images of the soccer field and stores the captured images. This will provide the possibility for creating video footage after a highlight has happened on the soccer field.

In some embodiments the camera system allows multiple smartphones to connect to the system. This would provide possibility for several operators to instruct the system when to create video footages.

In other embodiments the server 119 uploads footage to social media sites 120 without involving a smartphone 118. This may be done by specific programs running on the servers 119 that perform uploading of the video footage. One advantage is that uploading of video footage to the social media sites 120 can be performed automatically.

Fig. 7 shows a soccer field of the first embodiment where the angles of view of the master camera 105 are indicated. The master camera 105 is mounted at the first goal 103 and directed towards the second goal 104. An optional slave camera 106 may be mounted at the second goal 104. The master camera 105 comprises a first image capturing device 107 that is provided with a wide angle lens. The first image capturing device covers a first region 109. The master camera 105 also comprises a second image capturing device 108 that is provided with a telephoto lens. The second image capturing device covers a second region 110 that comprises the second goal structure 104. The angle of view for the first image capturing device is larger than the angle of view for the second image capturing device.

A second embodiment of a camera system for filming a sports venue is shown in Fig. 8. As shown in the Fig. 8 a master camera 105 may be mounted along one of the touchlines 101. In this embodiment the master camera is located close to the middle of the touchline 101. The master camera 105 is facing towards the second goal 104. The master camera 105 comprises a first image capturing device 107 that is

covering a first region 109 that comprises a second goal structure 104. Further the master camera 105 comprises a second image capturing device 108 covering a second region 110. The second region 110 is substantially within the first region 109. The first image capturing device has an angle of view that is larger than the angle of view of the second capturing device. The first image capturing device is preferably provided with a wide angle lens that may cover substantial parts of the half of the soccer field 100 close to the second goal 104. The second image capturing device 108 is provided with a telephoto lens to capture more details around the second goal 104. The camera may be mounted on a pole or a portable camera stand for rapid mounting.

In some embodiments the master camera is accompanied by a slave camera 106 that may be mounted at the same location as the master camera, where the master camera 105 and slave camera 106 are located along the touchline. The slave camera 106 is directed towards the first goal 103. The first image capturing device 107 of the slave camera is covering substantial parts of the half of the soccer field 100 close to the first goal 103. The second image capturing device 108 of the slave camera 106 is covering a region around the first goal 103. It would be advantageous to have the master and slave camera mounted a same location for rapid mounting of the system.

The camera system in the second embodiment may be operated similarly to the first embodiment. The second embodiment will differ by having the master camera face the second goal and the slave camera facing the first goal. The selection of images to transmit from the regions will still be valid.

In alternative embodiments the master and the slave cameras 105, 106 are mounted at locations comprising: along the goal lines 102, at the touchlines 101, at an intersection of the goal line 102 and at the touch line 101. The master and slave camera may be located at the same location or at separate locations.

In other embodiments the master camera 105 and the slave camera 106 are manufactured as a single unit. Where mounting of the single unit along a touchline 101 would provide for a rapid mountable system and where a single unit may cover substantial parts of a sports venue 100 for image capturing.

5

In an embodiment of the system at least one master camera 105 is mounted at a goal and at least a slave camera 106 is mounted at a touchline 101 facing towards a goal. This would provide a system where it would be possible to measure speed of objects due to viewing the soccer field 100 from at least two directions.

10

Fig. 9 shows an embodiment of the camera system using a drone 130. The drone 130 hovers over the sports venue 100. A camera 105, 106 is attached to the drone and captures images of the sports venue. The drone hovers over the sports venue 100. The drone may be an autonomous drone or a remote operated drone or a combination. The drone is preferably hovering at a fixed location over or beside the sports venue. Having the drone hovering at substantially fixed location there is no need for a physical structure for attaching the camera. The image capturing devices of the camera 105, 106 attached to the drone are filming towards a goal structure.

15

The drone may also move above and around the sports venue in controlled pattern.

20

The movement of the drone may decide autonomously to keep players, balls, specific actions or other in focus of the camera. There may be additional cameras located around the sports venue. The wide angle lens of the camera 105,106 is used to capture overview images of the sports venue. The overview images may be used to adjust the position of the drone, tracking of objects in the sports venue. The

25

telephoto lens of the camera 105,106 may be used to capture detailed images of the sports venue.

30

The drone may hover over or around the sports venue. It is advantageous for the drone to hover at a substantially fixed position. By using a drone there is less need for physical structures for attaching a camera. A drone is advantageous in that the system can rapidly be deployed at a sports venue. The drone may also hover at a static position and rotate itself such that the telephoto lens is pointing towards the

area where the ball or other relevant action is happening. The camera may also be attached to the drone using a motorized gimbal. The gimbal is used for stabilizing the camera and making sure that the camera may be pointed to the desired action at the sports venue.

5

The drone may hover above or beside the sports venue. The camera may film the sports venue vertically from above. This is of advantage in that location of the players and the ball is easier to determine.

10 In yet an embodiment (not shown) of the camera system a master camera is capturing images of the sports venue. Spectators at the sports venue may capture images using smartglasses, handheld cameras, smartphones or similar portable cameras. The portable camera may be connected to a wireless network at the sports venue. An application running on the portable camera preferably exchanges
15 captured images with the camera system and the server. The application may also exchange GPS coordinates or other information like direction, acceleration, timestamps etc. This additional information may be used for better estimates of location of the ball and players in the sports venue. The captured images from the portable cameras may be used to create video footage of the sports venue from
20 additional angles during a game. Timestamping the captured images may be used for easier creating and editing captured from multiple image capturing devices.

Fig .10 shows schematically multiple devices capturing images of a sports venue and transmitting the image to the server. One or more cameras 105 are capturing
25 images of the sports venue. Spectators are using their smartphone 118 to interact with the system using an app. The spectators film the action on the sports venue using a camera integrated in the smartphone 118 and the app on the smartphone transmits images to the server 119. In addition the app on the smartphone may transmit information related to the smartphone like GPS coordinates, direction,
30 compass heading, acceleration, timestamps etc. The GPS coordinates and the compass heading of the smartphone when capturing images may be used for easier tracking the location of objects on the sports venue. The heading and location data

may be used to create overlapping images, panning or other effects when creating video footage. The server processes the images captured by the camera 105, 106 and smartphones to create footage of the sports venue. This creating of the video footage may be done in real time or as post processing. In post processing the game play is known and the best view of the action is easier to select from all the available captured images of the match.

In other embodiments (not shown) the system comprises only smartphone cameras capturing images of the game. An app running on each of the smartphones captures images of the sports venue and uploads the images and information regarding the GPS coordinates, compass direction, acceleration, timestamps etc. of smartphones to the server. The server may in real time or in post processing create video footage of images captures of the sports venue.

The invention as described above may be embodied in many different forms and should not be construed as limited to any specific structure or function presented throughout this disclosure. Rather, these aspects are provided so that this disclosure will be thorough and complete, and will fully convey the scope of the disclosure to those skilled in the art. Based on the teachings herein one skilled in the art should appreciate that the scope of the disclosure is intended to cover any aspect of the disclosure disclosed herein, whether implemented independently of or combined with any other aspect of the disclosure. Further, the example above and the drawings are given to illustrate the invention, and should not be used to confine the invention as defined in the claims.

25

Claims

1. A camera system for filming a sports venue (100) comprising a first and a second goal structure (103,104), wherein the first and second goal structures
5 (103,104) are located substantially opposite each other, wherein the camera system further comprising:
- a first digital image capture device (107) covering a first region (109) of the sports venue (100),
 - a second digital image capture device (108) covering a second region
10 (110) of the sports venue (100),
 - wherein the first region (109) of the sports venue (100) comprises the second goal structure (104),
 - wherein the second region (110) of the sports venue (100) is a sub region located substantially within the first region (109) of the sports venue (100),
15 wherein the first and second digital image capture devices (107,108) are attached to a first attachment structure,
- characterised in** that the camera system further comprising processing means for processing received images captured from the first and second regions (109, 110) of the sports venue (100),
20 wherein the processing means further comprising means for selecting a region of the sports venue (100) for transmission,
- wherein the processing means selects transmission of images captured from the first digital image capture device (107) when selecting an area within the first region (109) of the sports venue (100), and
25 wherein the processing means selects transmission of images captured from the second digital image capture device (108) when selecting an area within the second region (110) of the sports venue (100).
2. Camera system according to claim 1, **characterised** in that the first
30 attachment structure is located along a first touchline (101).
3. Camera system according to claim 1, **characterised** in that the first attachment structure is located along a first goal line (102).

4. Camera system according to claim 1, **characterised** in that the first attachment structure is the first goal structure (103).
- 5 5. Camera system according to claim 1, **characterised** by further comprising means for determining a location of at least one ball in at least one received image.
6. Camera system according to claim 1, **characterised** by further comprising means for determining a location of at least one player in at least one received
10 image.
7. Camera system according to any of claims 5 to 6, **characterised** in that the camera system further comprises means for downscaling images from a first image dimension to a second image dimension for adapting the image dimension to the
15 recorded video dimension based on location in one received image of at least one object in a group comprising: a player and a ball.
8. Camera system according to any of claims 1 to 7, **characterised** in that the camera system further comprises means for slow motion video creation where
20 images are captured at a first framerate and recorded at a second framerate.
9. Camera system according to any of claims 1 to 8, **characterised** in that the camera system further comprising:
- 25 a third digital image capture device (107) covering a third region (109) of the sports venue (100),
a fourth digital image capture device (108) covering a fourth region (111) of the sports venue (100),
wherein the third region (109) of the sports venue (100) comprises the first goal structure (103),
30 wherein the fourth region (111) of the sports venue (100) is a sub region located substantially within the third region (109) of the sports venue (100),

wherein the third and fourth digital image capture devices (107,108) are attached to an attachment structure,

wherein the processing means selects transmission of images captured from the third digital image capture device (107) when selecting an area within the
5 third region (109) of the sports venue (100), and

wherein the processing means selects transmission of images captured from the fourth digital image capture device (108) when selecting an area within the fourth region (111) of the sports venue (100).

10 10. Camera system according to claim 9, **characterised** in that the attachment structure is located opposite of the first attachment structure.

11. Camera system according to claim 9, **characterised** in that the attachment structure is the first attachment structure.

15

12. Camera system according to claim 9, **characterised** in that the second attachment structure is the second goal structure (104).

13. Camera system according to claim 12, further comprising means for
20 determining a location of at least one ball in at least one received image from the image capture devices (107,108) on the first goal structure (103) and at least one received image from the image capture devices (107,108) on the second goal structure (104).

25 14. A method for operating a processing means in a camera system for filming a sports venue (100) comprising a first and a second goal structure (103, 104), wherein the first and second goal structures (103, 104) are located substantially opposite each other, wherein the camera system further comprising:

30 a first digital image capture device (107) covering a first region (109) of the sports venue (100),

a second digital image capture device (108) covering a second region (110) of the sports venue (100),

wherein the first region (109) of the sports venue (100) comprises the second goal structure (104),

wherein the second region (110) of the sports venue (100) is a sub region located substantially within the first region (109) of the sports venue (100),

5 wherein the first and second digital image capture devices (107, 108) are attached to a first attachment structure,

wherein the camera system further comprising processing means for processing received images captured from the first and second regions (109, 110) of the sports venue (100),

10 wherein the processing means further comprising means for selecting a region of the sports venue (100) for transmission,

wherein the processing means selects transmission of images captured from the first digital image capture device (107) when selecting an area within the first region (109) of the sports venue (100), and

15 wherein the processing means selects transmission of images captured from the second digital image capture device (108) when selecting an area within the second region (110) of the sports venue (100), **characterised in** that the processing means detects a ball on the sports venue and selects one of the at least one sub regions if the ball is located within said regions.

20

15. The method according to claim 14, **characterised in** that the processing means further detects when a ball crosses the half-way line and selects one of the at least one sub regions if the ball is located within said regions.

25

16. The method according to claim 14, wherein the processing means further detects when a ball crosses the half-way line and selects one of the at least one sub regions after an elapsed time or when the ball is at a certain distance from the half-way line.

30

17. A method according to claim 14 wherein, the processing means detects a player controlling a ball on the sports venue and selects a selected region if the ball and the player are located within said regions.

18. The method according to claim 17 wherein the camera system further selects transmission of images from the regions with the ball and the player depending on a direction of playing the ball.

5

19. The method according to claim 18, wherein the direction of playing the ball is taken to be the direction of the ball relative to the player.

20 The method according to claim 18, wherein the direction of playing the ball is taken to be in the direction of the goal structure that the player attempts to reach.

10

21. The method according to claim 17, wherein the camera system further selects transmission of images from the regions with the ball using the digital image capture device located generally closest to the ball.

15

22. The method according to claim 17, wherein the distance to the ball is determined by the vertical angle from the digital image capture devices to the ball.

20

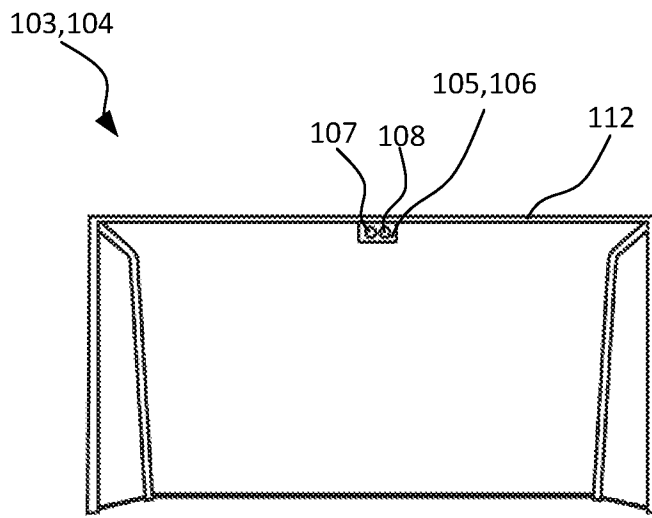

Fig. 1

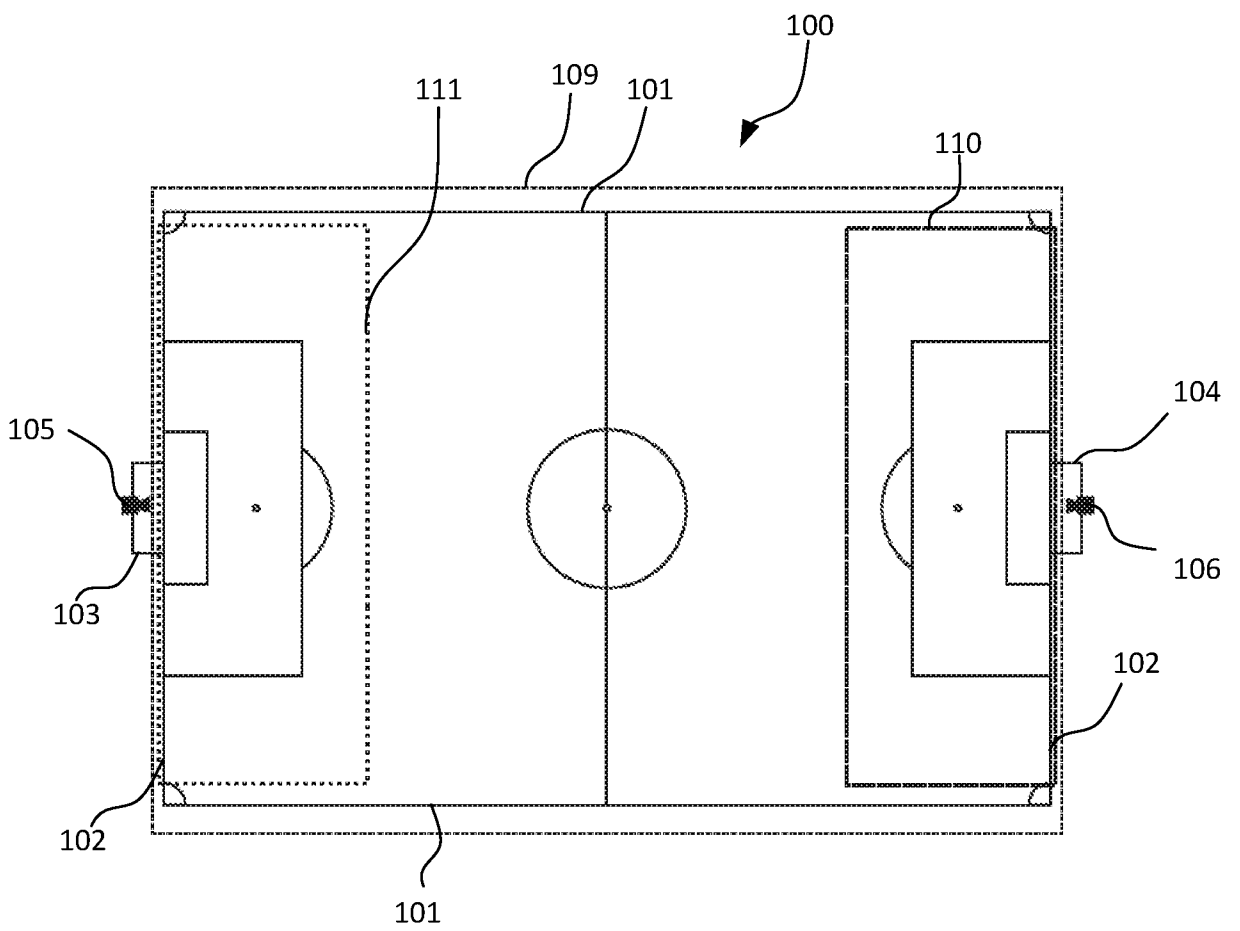

Fig. 2

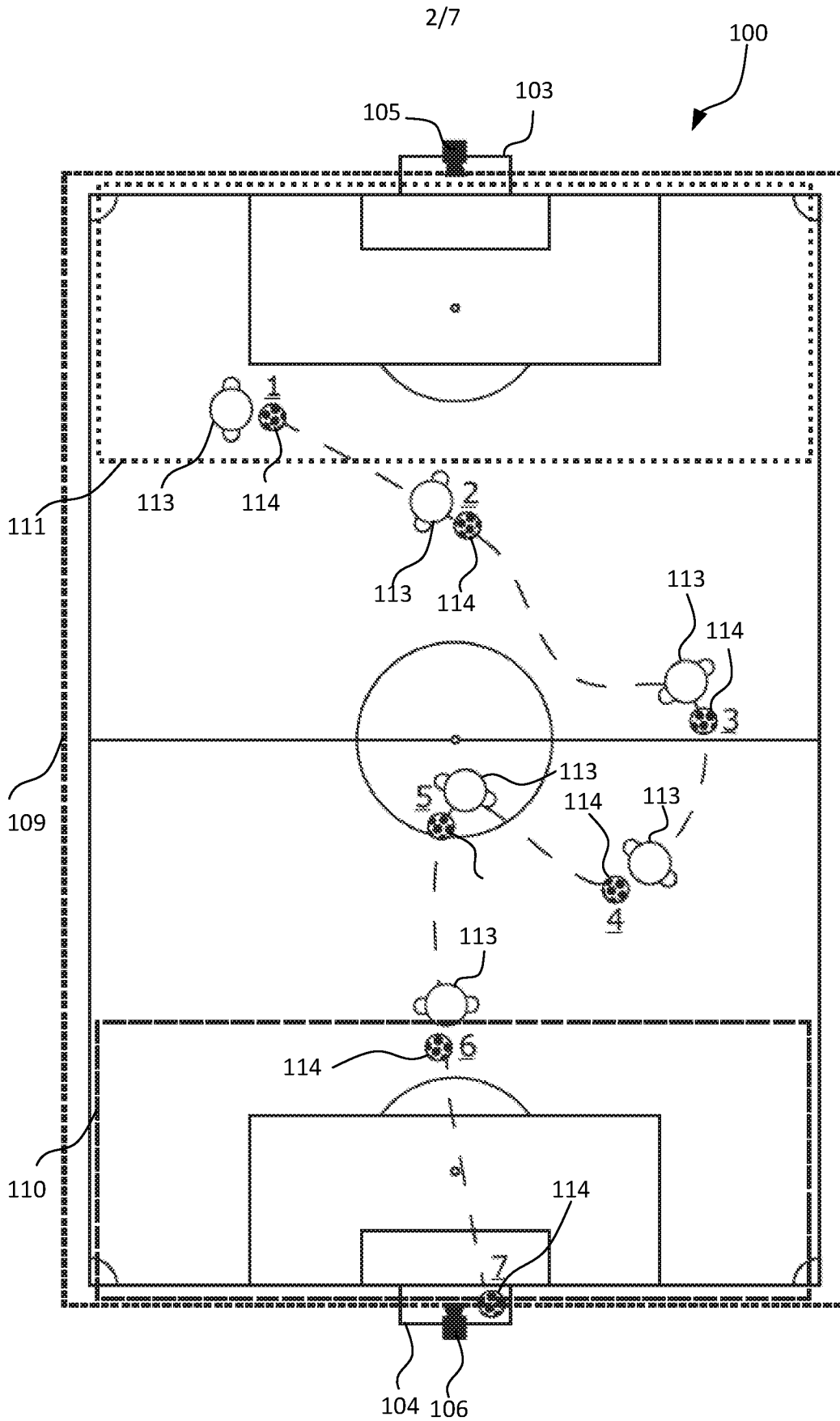

Fig. 3

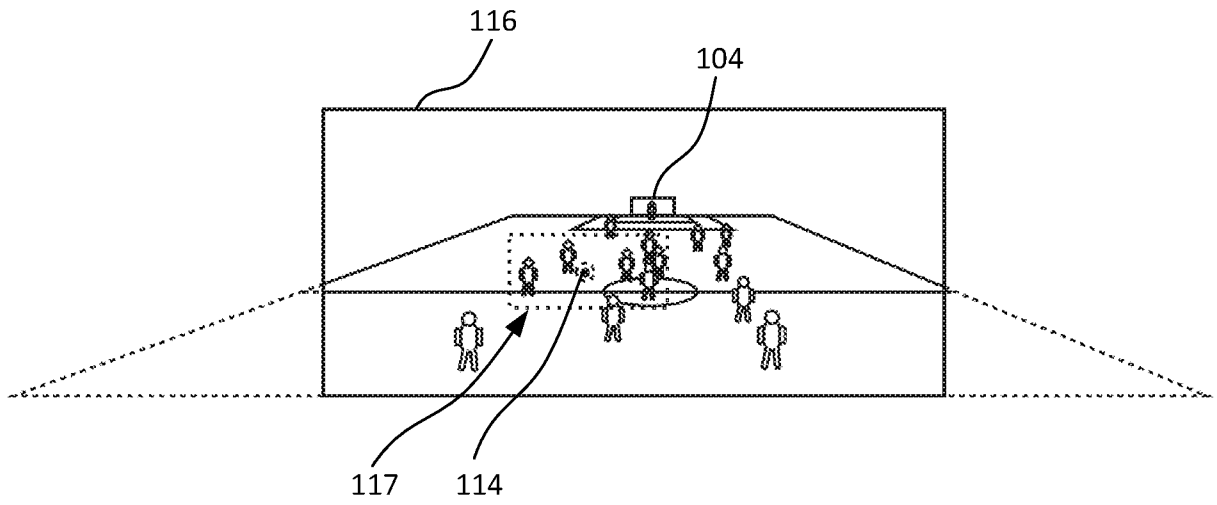

Fig. 4

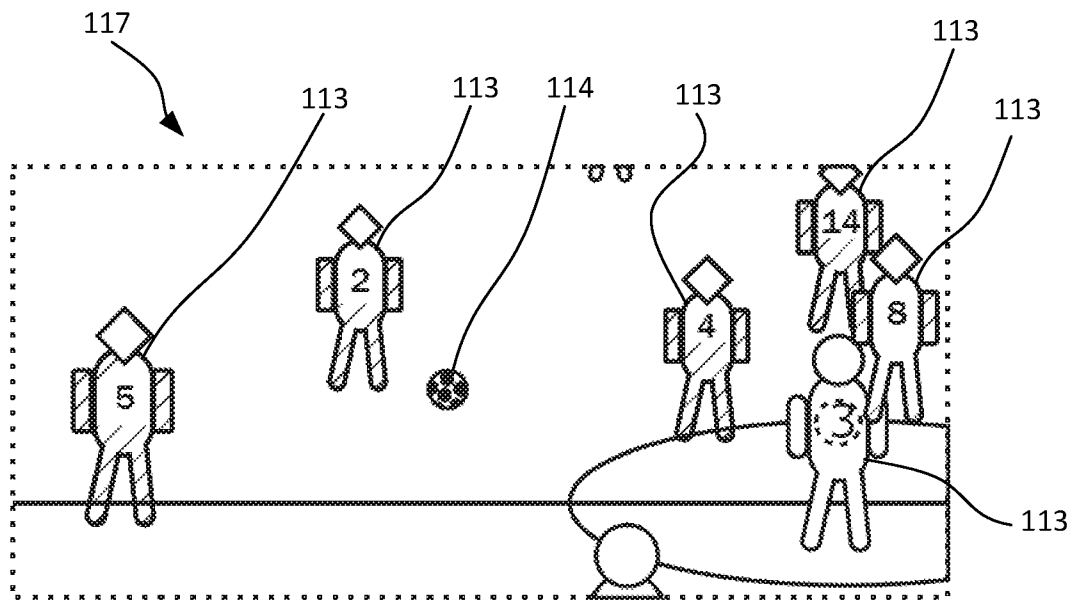

Fig. 5

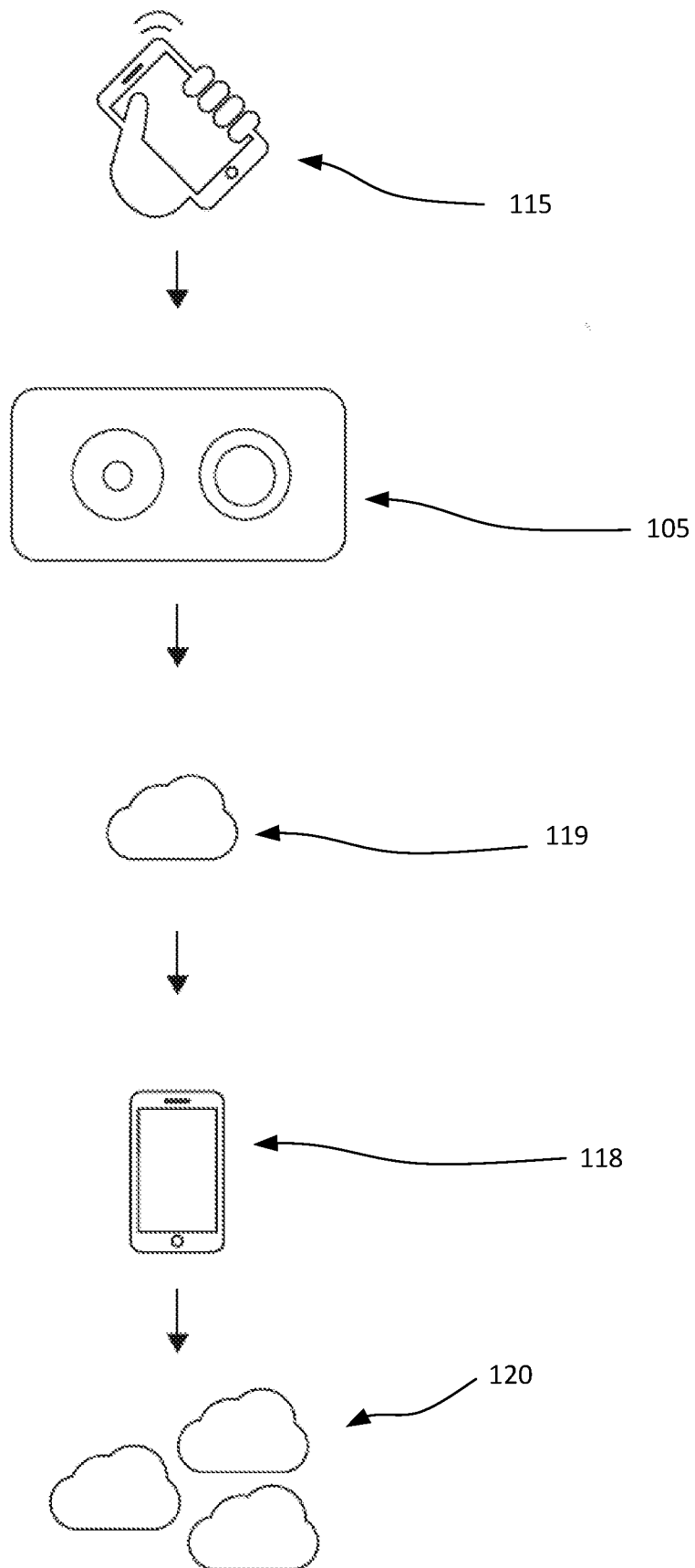

Fig. 6

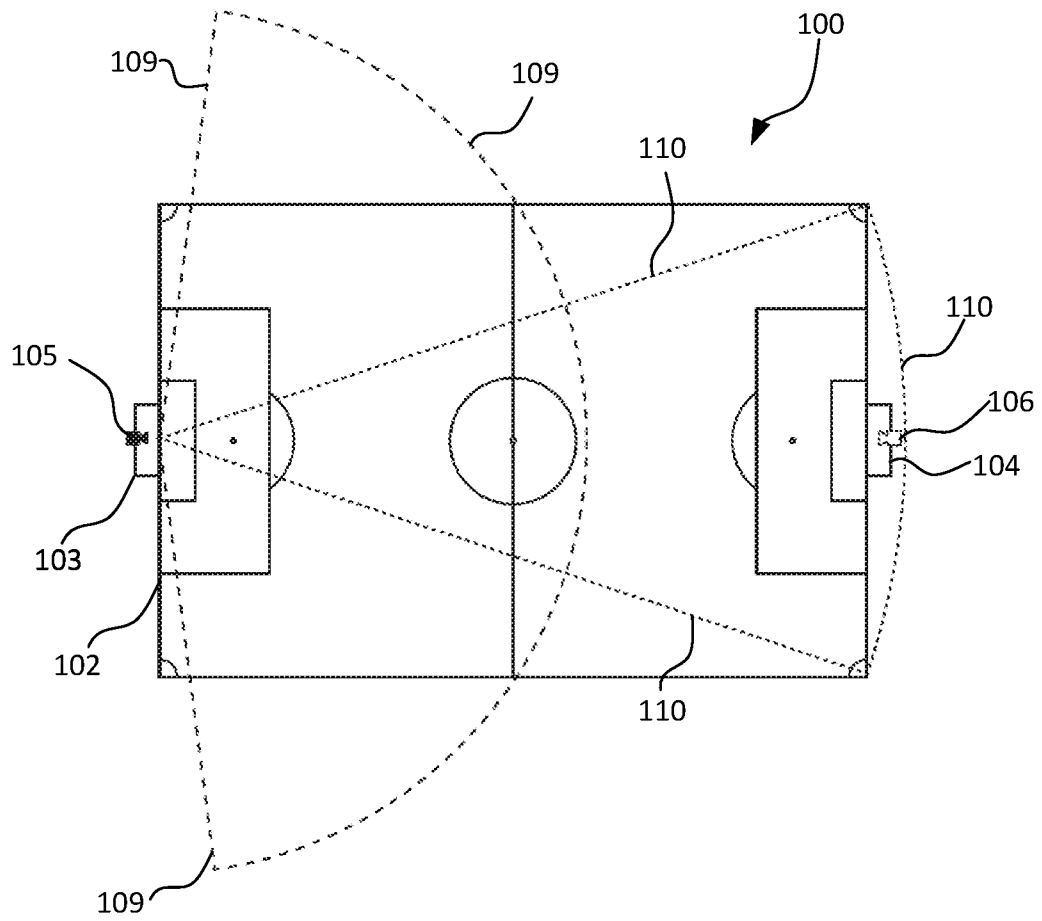

Fig. 7

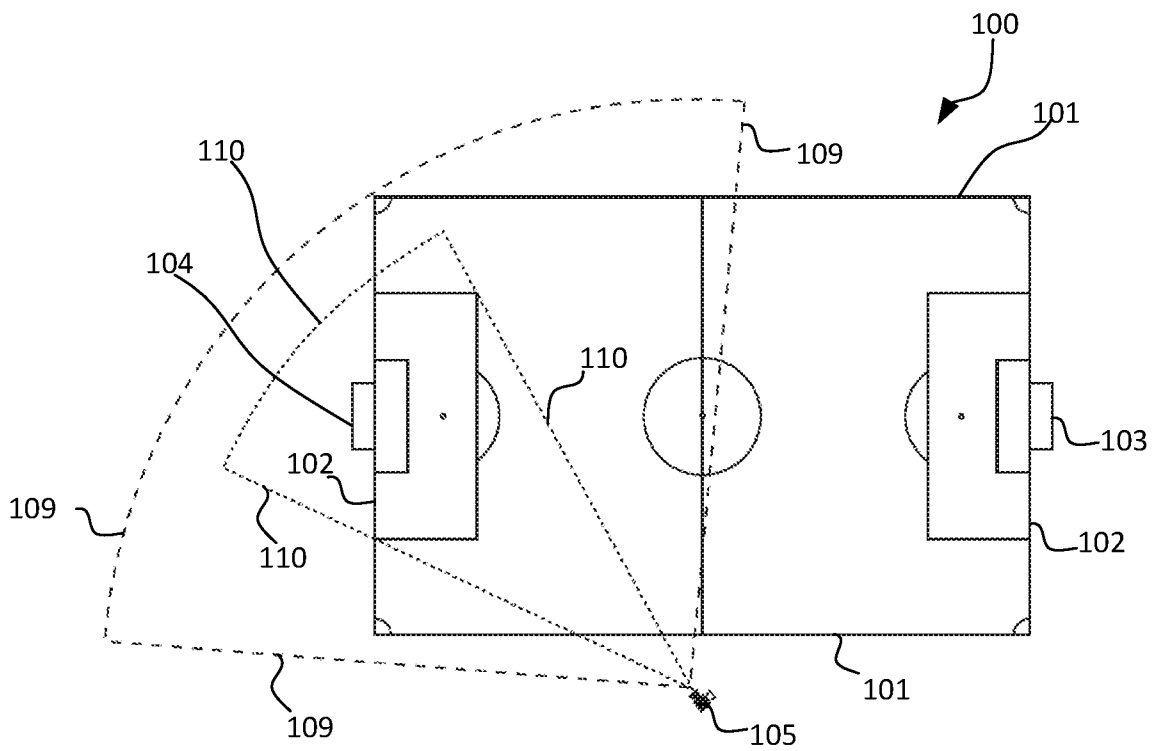

Fig. 8

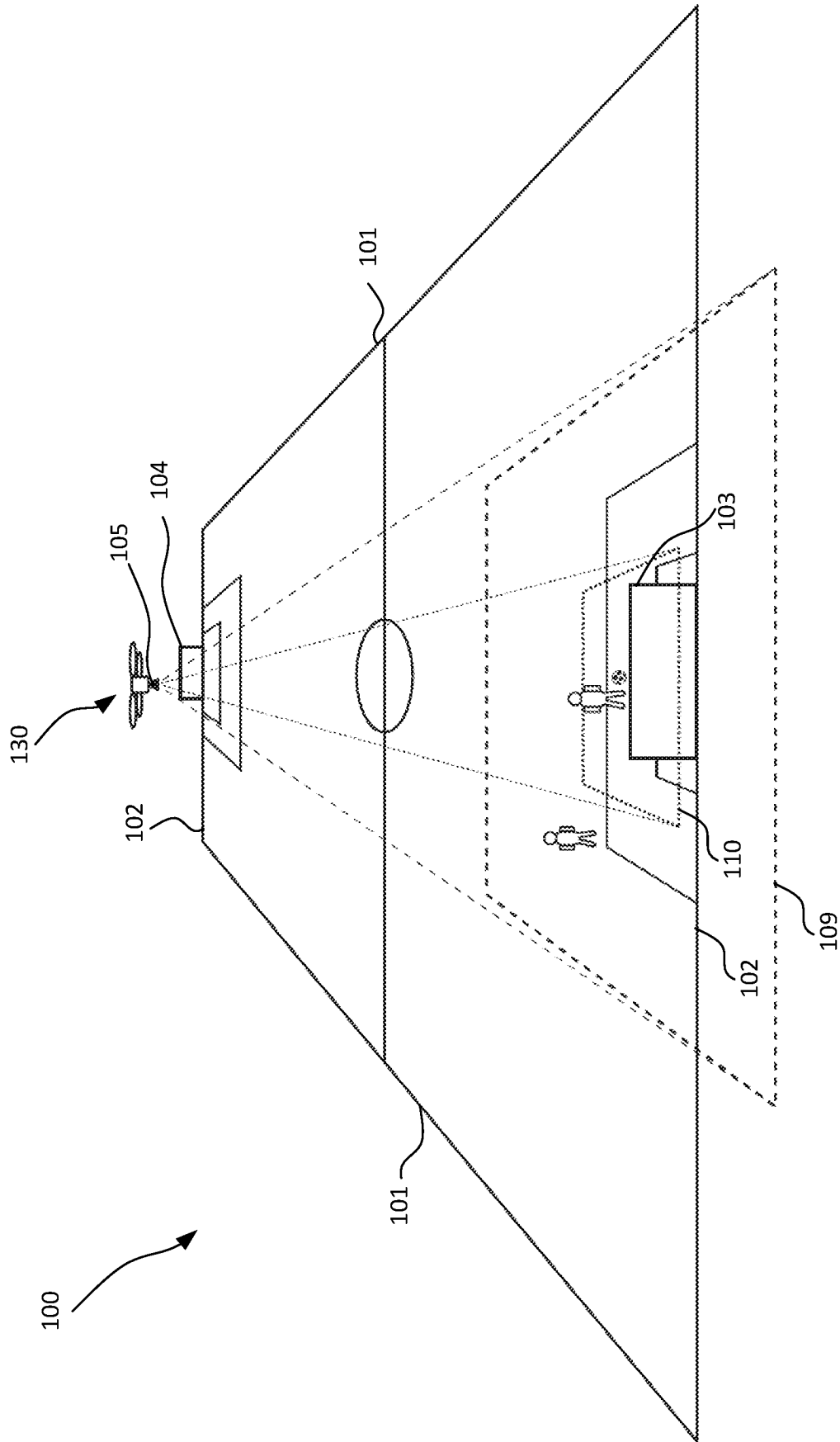

Fig. 9

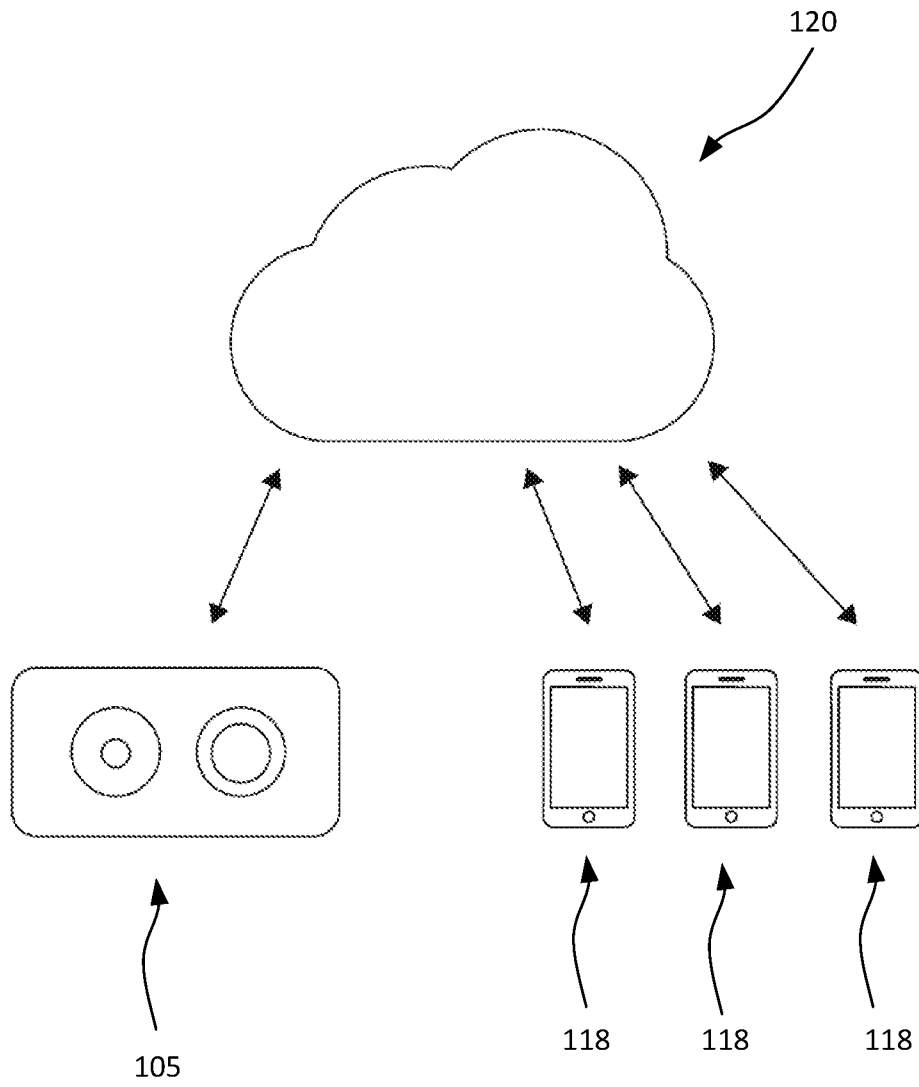

Fig. 10

INTERNATIONAL SEARCH REPORT

International application No.
PCT/NO2017/050170

A. CLASSIFICATION OF SUBJECT MATTER		
IPC: see extra sheet		
According to International Patent Classification (IPC) or to both national classification and IPC		
B. FIELDS SEARCHED		
Minimum documentation searched (classification system followed by classification symbols)		
IPC: G06F, G06K, H04N		
Documentation searched other than minimum documentation to the extent that such documents are included in the fields searched		
SE, DK, FI, NO classes as above		
Electronic data base consulted during the international search (name of data base and, where practicable, search terms used)		
EPO-Internal, PAJ, WPI data, COMPENDEX, INSPEC, MEDLINE		
C. DOCUMENTS CONSIDERED TO BE RELEVANT		
Category*	Citation of document, with indication, where appropriate, of the relevant passages	Relevant to claim No.
Y	WO 2015100116 A1 (TELEMETRIO LLC), 2 July 2015 (2015-07-02); abstract; paragraphs [0025]-[0032], [0049]-[0055], [0058]-[0060], [0095]; figures 1,3,5,11-14 --	1-22
Y	US 20150264258 A1 (BERVOETS ALFONSUS MARIA ET AL), 17 September 2015 (2015-09-17); paragraphs [0006]-[0015], [0051]-[0053], [0063]-[0068], [0090]-[0094]; figures 1,2,7-8	1-6, 9-22
A	--	7-8
<input checked="" type="checkbox"/> Further documents are listed in the continuation of Box C. <input checked="" type="checkbox"/> See patent family annex.		
* Special categories of cited documents: "A" document defining the general state of the art which is not considered to be of particular relevance "E" earlier application or patent but published on or after the international filing date "L" document which may throw doubts on priority claim(s) or which is cited to establish the publication date of another citation or other special reason (as specified) "O" document referring to an oral disclosure, use, exhibition or other means "P" document published prior to the international filing date but later than the priority date claimed "T" later document published after the international filing date or priority date and not in conflict with the application but cited to understand the principle or theory underlying the invention "X" document of particular relevance; the claimed invention cannot be considered novel or cannot be considered to involve an inventive step when the document is taken alone "Y" document of particular relevance; the claimed invention cannot be considered to involve an inventive step when the document is combined with one or more other such documents, such combination being obvious to a person skilled in the art "&" document member of the same patent family		
Date of the actual completion of the international search 19-10-2017		Date of mailing of the international search report 19-10-2017
Name and mailing address of the ISA/SE Patent- och registreringsverket Box 5055 S-102 42 STOCKHOLM Facsimile No. + 46 8 666 02 86		Authorized officer Jenny Wallner Telephone No. + 46 8 782 28 00

INTERNATIONAL SEARCH REPORT

International application No.
PCT/NO2017/050170

C (Continuation). DOCUMENTS CONSIDERED TO BE RELEVANT		
Category*	Citation of document, with indication, where appropriate, of the relevant passages	Relevant to claim No.
Y	WO 0124515 A1 (KONINKL PHILIPS ELECTRONICS NV), 5 April 2001 (2001-04-05); abstract; page 1, line 28 - page 2, line 33; page 3, line 26 - page 4, line 2; page 14, line 6 - line 11; figure 10 --	1-22
A	EP 0345982 A1 (TECHNO TIP), 13 December 1989 (1989-12-13); column 1, line 1 - line 40; figures --	1-22
A	WO 2013026991 A1 (THOMAS DAVID JOHN), 28 February 2013 (2013-02-28); abstract; page 6, line 12 - page 8, line 17; page 12, line 14 - page 14, line 6; figures 1-10 --	1-22
A	WO 2016054729 A1 (LIVEBARN INC), 14 April 2016 (2016-04-14); abstract; page 3, line 10 - page 8, line 21; figures 1-4 --	1-22
P, A	M. Manafifard, H. Ebadi, H. Abrishami Moghaddam, 2017, A survey on player tracking in soccer videos, vol 159, Computer Vision and Image Understanding, p. 19-46, ISSN 1077-3142; whole document -- -----	1-22

INTERNATIONAL SEARCH REPORT

Information on patent family members

International application No.

PCT/NO2017/050170

WO	2015100116 A1	02/07/2015	US	20150189243 A1	02/07/2015
US	20150264258 A1	17/09/2015	EP	2966851 A1	13/01/2016
			NL	2012399 B1	26/11/2015
WO	0124515 A1	05/04/2001	EP	1133868 A1	19/09/2001
			JP	2003510666 A	18/03/2003
			US	6734911 B1	11/05/2004
EP	0345982 A1	13/12/1989	DE	68900156 D1	29/08/1991
			ES	2025362 T5	16/03/1992
			GB	2219710 A	13/12/1989
			GR	3002997 T3	25/01/1993
WO	2013026991 A1	28/02/2013	NONE		
WO	2016054729 A1	14/04/2016	AU	2015330646 A1	01/06/2017
			CN	107005654 A	01/08/2017
			EP	3205112 A1	16/08/2017
			KR	20170086493 A	26/07/2017
			US	20170001118 A1	05/01/2017
			US	9744457 B2	29/08/2017
			US	20160101358 A1	14/04/2016
			US	9468850 B2	18/10/2016

Continuation of: second sheet

International Patent Classification (IPC)

H04N 5/247 (2006.01)

G06F 17/30 (2006.01)

G06K 9/20 (2006.01)

H04N 5/268 (2006.01)

H04N 7/00 (2011.01)