

W. O. BARNES.
 BAYONET JOINT.
 APPLICATION FILED MAR. 4, 1908.

1,002,115.

Patented Aug. 29, 1911.

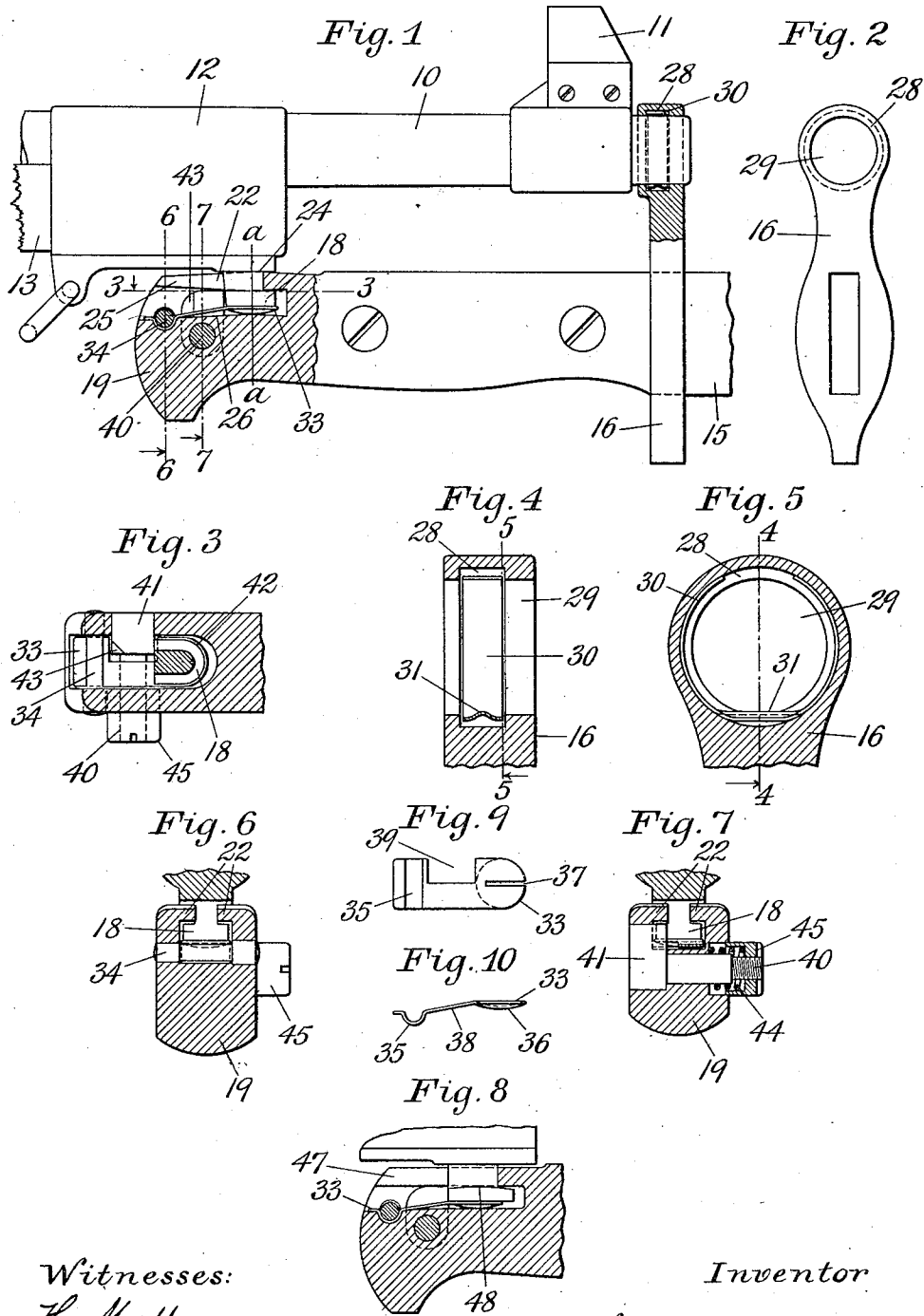

Witnesses:
H. Mallner
Caroline M. Breckle

Inventor
William O. Barnes
 By *W. A. House* Atty.

UNITED STATES PATENT OFFICE.

WILLIAM O. BARNES, OF QUEBEC, QUEBEC, CANADA.

BAYONET-JOINT.

1,002,115.

Specification of Letters Patent. Patented Aug. 29, 1911.

Application filed March 4, 1908. Serial No. 419,123.

To all whom it may concern:

Be it known that I, WILLIAM O. BARNES, a citizen of the United States, and resident of Quebec, in the Province of Quebec and Dominion of Canada, have invented certain new and useful Improvements in Bayonet-Joints, of which the following is a full, clear, and exact specification.

This invention relates to improvements in bayonet joints for attaching bayonets in a fixed position for service upon the end of, and preferably beneath, the barrel of a rifle or other firearm.

The objects of this invention are in general to provide a joint which securely holds the bayonet in its seat upon, and in the desired relation to, the end of the rifle or other firearm; to enable the bayonet to be easily and quickly attached in place in the desired alinement or parallelism or other desired relation to the barrel, and to be as readily removed therefrom even though the parts may have become rusted or clogged with dirt; to make the parts of simple construction so that they can be manufactured at a low cost, and may be used interchangeably with each other and with the firearm upon which they are to be used; and to make the attaching joints of such a character that they will take up whatever looseness may be due to variations in manufacture or to wear, so as to insure snug fitting of the bayonet and avoid rattling of the joints.

My preferred embodiment of this invention is illustrated in the accompanying sheet of drawings, in which—

Figure 1 is a side view showing the front end of a rifle barrel and the rearward end of a bayonet connected together. Fig. 2 is a front view projected from the right hand end of Fig. 1, showing mainly the blade of the bayonet and the guard or cross piece thereof. Fig. 3 is a plan view in section taken on the line 3—3 of Fig. 1. Figs. 4 and 5 are enlarged views showing details of the connection between the cross piece of the bayonet and the end of the barrel. Fig. 4 is a side view in section taken on the line 4—4 of Fig. 5; and Fig. 5 is an end view in section taken on the line 5—5 of Fig. 4. Fig. 6 is an end view in section taken on the line 6 of Fig. 1. Fig. 7 is a similar end view taken on the line 7—7 of Fig. 1. Fig. 8 is a side view in section, similar to that of Fig. 1, showing a modified arrangement of the rearward joint.

Fig. 9 is a plan view, and Fig. 10 a side view of the spring preferably employed in connection with the rearward joint between the bayonet and the firearm.

In the embodiment shown in the drawings, the barrel 10 is provided with a front sight 11, and with a front band 12 for securing forestock 13 to the barrel. These parts are, or may be, of any ordinary or convenient construction.

The bayonet is attached to the barrel at two points at a substantial distance apart, so as to give an extended base of support to the bayonet to fix it firmly in position. The front attachment is therein shown to be made by the guard or cross-piece 16 forming an extension of the bayonet guard, which is provided with an aperture for receiving the end of the barrel or any suitable stud on the firearm. The rear attachment is preferably made between the pommel end of the hilt and the front band 12, the latter being in the present instance provided with a T-shaped knob 18, which engages with a T-slot in the pommel 19 of the bayonet.

For various practical reasons it is desirable to have the joints, by which the bayonet is attached to the firearm, fit closely together at the attached position, so as to have a firm connection; and also to avoid rattling noises. On the other hand, it is desirable to make these joints so that the bayonets can be quickly and surely attached, particularly in cases of emergency, when in haste, and in the dark. If the joints, which may be designated as slip joints, were made to fit closely throughout their sliding contact, they would be difficult to enter, and would be liable to cramp in moving them to their fixed position. On account of the difficulty of entering the two separate joints at the same time, the rearward joint is made longer than the other, and the bayonet is first attached at this joint, the members of which are slid together until the members of the other joint meet and interlap. During this initial sliding movement of the members of the first or rearward joint, before they are guided and steadied by the union of the second or front joint, the bayonet should be free to rock considerably upon the rearward joint so as to avoid cramping therein, due to unskilful or unsteady manipulation, in the dark, or by an unskilled recruit. These de-

5 sirable objects are attained in the present
 invention. The rearward joint fits closely
 only at those portions of the joint surfaces
 which are in contact when the bayonet is
 10 fully seated, these surfaces being herein des-
 igned as a contact seat at and adjacent
 to the line *a— a* of Fig. 1. The surfaces of
 one or both of the joint members adjacent
 15 to their contact seat are rounded or other-
 wise relieved, thus allowing the bayonet to
 rock freely in this joint in a lateral direction
 until the second or front joint is made,
 which brings the bayonet into proper align-
 20 ment or parallelism with the barrel, where-
 upon the members of the rearward joint are
 brought to their close fitting position. This
 arrangement prevents the bayonet from
 catching or cramping at its rearward end
 25 during the act of attaching it to the gun,
 and avoids the necessity of guiding the
 front end of the bayonet in any exact re-
 lation up to the time that the second joint
 is made. It also enables the two parts to be
 30 joined firmly together, in spite of varia-
 tions that may occur in the manufacture of
 the parts. The surfaces of the T-slot are
 inclined or flared at their rearward ends,
 so as to afford a wide entrance for the
 knob.

35 In the arrangement shown in Figs. 1 to 7
 inclusive, the joint is made by the flanges 22
 of the T slot projecting inwardly toward
 each other into the neck portion of the knob
 40 18, and between the under side of that knob
 and the surface 24 of the front band 12.
 The final or contact seat of the joint is at or
 adjacent to the plane indicated by the line
a— a in Fig. 1, at which plane the flanges 22
 45 closely fill the space between the head of
 the knob and the surface 24. The upper and
 lower surfaces of the flanges 22 are relieved
 both forwardly and rearwardly from the
 contact seat to permit the desired rocking
 50 movement of the joint. The flanges 22 taper
 from the contact seat toward their rearward
 ends 25, thus enabling those ends to enter
 the neck of the knob freely in the operation
 of attaching the bayonet. The bottom sur-
 55 face 26 of the T-slot in the pommel is also
 inclined downwardly, so that both the upper
 and lower surfaces of this portion of the T-
 slot are flared to permit the easy entrance
 of the head of the knob into the rearward
 end of the T-slot.

60 In the embodiment of the invention herein
 shown the front joint is made between the
 guard or cross-piece 16 of the bayonet and
 the end of the barrel or muzzle, although
 that joint, or a similar joint, could be made
 65 between any suitable members or appur-
 tenances of the bayonet and the barrel. The
 upper end of the cross-piece 16 is bored at
 29 to receive the end of the muzzle as shown
 in Figs. 1 and 2, and to fit with a reasonable
 degree of closeness, which, however, depends

upon the limits of variation recognized or
 allowed in the manufacture of the parts, this
 variation differing with different manufac-
 turers, according to the skill of their work-
 70 men, or their other facilities for doing close
 work. Even in the best practice it is, how-
 ever, considered necessary to provide for
 variations of some degree; hence the cross-
 piece is bored to the largest limit size of
 75 the barrels, and means are provided for tak-
 ing up the looseness in the varying degrees
 of smaller sizes, so as to avoid in all of
 them the liability of rattling. In the pres-
 ent instance this is provided for by making
 80 an annular recess 28 in the bore 29 of the
 cross-piece, and placing in that recess a ring
 or band-shaped spring 30, the form and dis-
 position of which is best shown in large
 scale in Figs. 4 and 5. The circle of the
 85 spring 30 is preferably larger than the circle
 of the bore 29, so that that spring, or at
 least the edge portions thereof, lie outside of
 that circle of that bore to avoid presenting
 abrupt shoulders to the entrance of the bar-
 90 rel. Those portions of the spring which are
 to contact with the barrel are bent inwardly
 so as to form crimps 31 in the spring at
 about the middle of its width, as shown in
 Fig. 4. Only one of these crimps is herein
 95 shown, but their number is immaterial and
 depends upon the size of the barrel and
 whether it is round, octagonal, hexagonal,
 etc., it being considered generally advisable
 to hold the barrel at three points disposed
 100 about equally around its perimeter, one of
 which points of contact may be directly be-
 tween the barrel and the one side of the bore
 29. These crimps present inclined faces to
 the entering edges of the barrel.

105 What has herein been said about the de-
 sirability of providing for variations in the
 practical manufacture of firearms, applies
 also to the rearward joint, and provision is
 also there made for taking up whatever
 110 looseness may result from such variations or
 from the wear of the parts. In that case a
 spring 33 is seated in the pommel of the
 bayonet and held by means of a pin 34. The
 pin is preferably provided with an annular
 115 groove at about the middle of its length, in
 approximate conformity with the width and
 thickness of the spring 33 at that point, as
 shown in Figs. 1, 3 and 6, the corresponding
 portion of the spring being bent around
 120 the pin, so as to fit in the annular groove of
 the pin and between the shoulders thereof.
 Thus the pin holds the spring in position
 and is itself held by the spring against end-
 wise movement. The center of the hole for
 125 the pin 34 is drilled approximately in the
 plane of the surface 26 of the T-slot, so that
 the half circle of the pin 34 is below the
 plane of the surface 26, that surface being
 recessed to receive the downwardly curved
 130 portion 35 of the spring. That recess is

made deep enough to allow the said curved portion 35 of the spring to be sprung down while driving the pin 34 through to its place, so as to allow the enlarged end of the pin to pass over the spring. One of the ends of the pin may be larger than the other, as shown in Fig. 6, and in other ways may be adapted to facilitate the assembling and disassembling of the parts. That portion 36 of the spring 33 which bears against the knob 18 is preferably cupped as shown in Fig. 10, and split, as shown at 37 in Fig. 9, so as to form a resilient yet sufficiently stiff seat between the knob 18 and the bottom surface 26 of the T-slot when the knob is at its attaching position shown in Fig. 1. The intermediate portion 38 of the spring is preferably inclined so as to impose a resilient resistance to the entrance of the knob, and give a feeling of firmness in the operation of fixing the bayonet.

As a means for latching the bayonet endwise in position, I have herein shown a well-known form of latching bolt, consisting of a spring bolt 40, which passes transversely through the pommel below the T-slot. The enlarged head 41 of the bolt projects upwardly into the path of movement of the knob, and locks behind the knob, as shown in Figs. 3, 7 and 8, when the bayonet is seated in place. The forward end of the knob is rounded or beveled, as shown at 42, and the head of the bolt may also be beveled or rounded, as shown at 43 in Figs. 1 and 3 to enable the head to push the bolt back automatically as the knob enters the rearward end of the T-slot. The bolt is yieldingly held to its locking position by means of a spring 44, which is seated in a counterbored portion of the pommel, beneath the screw cap 45, which serves as a convenient button by means of which the bolt may be retracted by the thumb or finger of the soldier, when attaching the bayonet to or detaching it from the firearm. This locking mechanism, however, is of well-known construction, and forms no part of the present invention. If such a latch bolt is used a portion of the spring 33 should be cut away as shown at 39 in Fig. 9, to clear the head of the bolt.

Various modifications may be made in these parts for securing the objects and ends described. One of these modifications is shown in Fig. 8, in which the flanges 47 are made parallel instead of tapering, the upper side 48 of the knob 49 being rounded to permit the desired rocking movement and also to facilitate the easy entrance of the knob between the underside of the flange 47 and the top surface of the spring 33, the construction and operation of which are like those of the previous figures. Obviously also the spring 33 may be omitted from this and any of the other forms shown, and the

seating contact be made between the top and bottom surfaces of the T-slot and the upper and lower sides of the head, those sides of the head being rounded as shown by the rounded side 48 in Fig. 8 to permit of the required rocking movement; or the under surface 24 of the band shown in Fig. 1 may be rounded like the under surfaces of the flanges 22 in Fig. 1. The underside of the knob may be rounded as shown in Fig. 8, either with tapering flanges 35, as shown in Fig. 1, or with those flanges made substantially parallel as in Fig. 8. In many such ways which will be apparent to those skilled in this art, the details of the invention may be reversed, transposed, or otherwise modified to suit different conditions of manufacture or use, or to suit the preferences of purchasers.

I claim as my invention:—

1. Means for attaching bayonets to firearms, comprising a knob appurtenant to one of said members, and flanges appurtenant to the other member for receiving the said knob between them, one of the contact surfaces between the knob and the said flanges being rounded or inclined to facilitate the entrance of the knob and permit correct alinement and seating of the bayonet in attaching it to the firearm.

2. Means for attaching bayonets to firearms, comprising a knob appurtenant to the firearm, flanges appurtenant to the bayonet for receiving the knob between them with the head of the knob projecting beneath the flanges, the contacting surfaces of the flange and the knob at the seating position of the knob forming a joint fitting more closely than elsewhere, to permit rocking movement of the bayonet relative to the firearm, to facilitate attachment in correct relative position and alinement.

3. Means for attaching bayonets to firearms, comprising a knob appurtenant to the firearm, flanges appurtenant to the bayonet for receiving the knob between them with the head of the knob projecting beneath the said flanges, the upper and lower surfaces of said flanges being adapted to fit the knob closely at its seating position, and being inclined or relieved from the said seating position toward the ends of the flanges to facilitate the entrance of the knob and permit proper positioning of the bayonet relative to the firearm.

4. Means for attaching bayonets to firearms, comprising a knob appurtenant to the firearm, flanges appurtenant to the bayonet, forming a joint with the knob, having a rounded seat to permit rocking movement of the bayonet thereon, to facilitate the attaching of the bayonet, the latter being also provided with a second attaching member for engaging with the firearm.

5. A bayonet provided with means for

detachably securing the bayonet to firearms, and a spring appurtenant to one of the joint members, and bearing against the other joint member for taking up the looseness of the joint.

5 6. A bayonet and firearm provided with a joint for detachably connecting them together, and a spring appurtenant to the bayonet, and forming one of the surfaces
10 of the joint for taking up the looseness of the said joint.

7. A bayonet and firearm provided with a plurality of detachable joints for connecting them together, each of said joints being
15 provided with a resilient member forming part of the joint surface for taking up the looseness and wear of the said joints.

8. A bayonet and firearm provided with slip joints for detachably connecting them
20 together, one of said joints being provided with a spring, forming one of the joint surfaces, the said spring being detachably held in position adjacent to its joint.

9. The combination, with a bayonet provided with a slip joint, of a spring forming
25 one of the bearing surfaces of the said joint, and means for detachably securing the spring in position adjacent to the said joint, comprising a pin seated in the said bayonet,
30 the spring being bent partway around the pin and seated in a recess adjacent to the said pin.

10. The combination, with a bayonet provided with a slip joint, of a spring forming
35 one of the bearing surfaces of the said joint, and means for detachably securing the spring in its place in the joint, consisting of a pin having an annular recess forming a seat for one side of the spring, the latter
40 being bent partway around the pin in the said recess, and being seated in a recess also partly surrounding the said pin, whereby the pin secures the spring, and the spring by means of its annular seat in the pin holds the
45 latter against unintentional dislodgment.

11. A bayonet, and means for securing it to a firearm, comprising a knob appurtenant to the firearm, a seat in the pommel of the bayonet for receiving the knob, and a
50 spring appurtenant to the pommel of the bayonet and bearing against the head of the knob to take up looseness and wear.

12. A bayonet and a firearm, and means including a slip joint for removably attaching
55 them together, and means for taking up the looseness and wear of the joint, comprising a spring having a cupped portion forming one of the surfaces of the joint.

13. The combination, with a bayonet, and

firearm, of a self alining joint for attaching
60 ing them together, consisting of a member appurtenant to the bayonet provided with an aperture for receiving the coengaging member of the firearm, the said aperture
65 being recessed to receive a spring, and a spring seated in said recess and resiliently bearing against the said coengaging member of the firearm.

14. Means for attaching a bayonet to a firearm, comprising a member appurtenant
70 to the bayonet provided with an aperture for receiving an attaching member of the firearm, an annular recess in the said aperture, and a curved spring seated in said annular recess, and resiliently bearing against
75 the said attaching member of the firearm.

15. Means for attaching a bayonet to a firearm, comprising a member appurtenant
to the bayonet provided with an aperture for receiving an attaching member of the fire-
80 arm, an annular recess in the said aperture, and a curved spring seated in said annular recess provided with a raised surface bearing against the said attaching member.

16. Means for attaching a bayonet to a
85 firearm, comprising a member appurtenant to the bayonet provided with an aperture for receiving the barrel of the firearm, an annular recess in the said aperture, and a ring-like spring seated in said recess and
90 bearing against the barrel.

17. Means for attaching a bayonet to a firearm, comprising a member appurtenant
to the bayonet provided with an aperture for receiving the barrel of the firearm, an
95 annular recess in the said aperture, and a ring-like spring seated in said recess and bearing against the barrel, the spring being provided with a rounded crimp bearing
100 against the barrel.

18. The combination in a bayonet and firearm, of self-adjusting joints for removably
but firmly attaching them together, consisting of a knob, and a slotted recess for attaching
105 the pommel of the bayonet to the firearm, and of an aperture in the cross piece of the bayonet for receiving the barrel of the firearm, the said aperture being provided with an annular recess, and with a ring-like spring seated in said recess and
110 bearing against the barrel.

In testimony whereof I have signed my name to this specification in the presence of two subscribing witnesses.

WILLIAM O. BARNES.

Witnesses:

FRED B. PAULIN,
W. A. FELLOWS.