

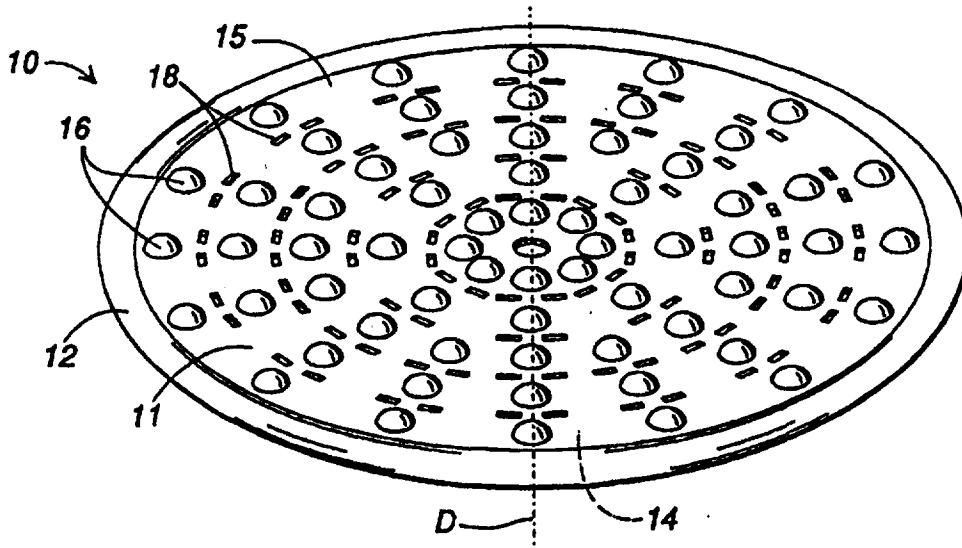

## INTERNATIONAL APPLICATION PUBLISHED UNDER THE PATENT COOPERATION TREATY (PCT)

<p>(51) International Patent Classification <sup>6</sup> : A63H 27/00, 33/00</p>	<p>A1</p>	<p>(11) International Publication Number: <b>WO 98/09698</b> (43) International Publication Date: 12 March 1998 (12.03.98)</p>
<p>(21) International Application Number: PCT/US97/15190 (22) International Filing Date: 28 August 1997 (28.08.97) (30) Priority Data: 08/707,240 3 September 1996 (03.09.96) US (71)(72) Applicant and Inventor: JOHNSON, Lonnie, G. [US/US]; 4030 Ridgehurst Drive, Smyrna, GA 30080 (US). (72) Inventor: APPLEWHITE, John, T.; 138 Belmonte Drive, S.W., Atlanta, GA 30311 (US). (74) Agent: KENNEDY, Dorian, B.; Kennedy, Davis &amp; Kennedy, 400 Northpark Town Center, Suite 1250, 1000 Abernathy Road, Atlanta, GA 30311 (US).</p>		<p>(81) Designated States: AL, AM, AT, AU, AZ, BB, BG, BR, BY, CA, CH, CN, CZ, DE, DK, EE, ES, FI, GB, GE, HU, IL, IS, JP, KE, KG, KP, KR, KZ, LK, LR, LS, LT, LU, LV, MD, MG, MK, MN, MW, MX, NO, NZ, PL, PT, RO, RU, SD, SE, SG, SI, SK, TJ, TM, TR, TT, UA, UG, UZ, VN, ARIPO patent (GH, KE, LS, MW, SD, SZ, UG, ZW), Eurasian patent (AM, AZ, BY, KG, KZ, MD, RU, TJ, TM), European patent (AT, BE, CH, DE, DK, ES, FI, FR, GB, GR, IE, IT, LU, MC, NL, PT, SE), OAPI patent (BF, BJ, CF, CG, CI, CM, GA, GN, ML, MR, NE, SN, TD, TG).</p> <p><b>Published</b> <i>With international search report.</i></p>

(54) Title: FLYING DISK



## (57) Abstract

A flexible, limp flying disk (10) having a body portion (11) and a peripheral lip (12). The body portion has an annular array of bumps (16) for lift and an annular array of openings (18) therethrough for stability.

**FOR THE PURPOSES OF INFORMATION ONLY**

Codes used to identify States party to the PCT on the front pages of pamphlets publishing international applications under the PCT.

AL	Albania	ES	Spain	LS	Lesotho	SI	Slovenia
AM	Armenia	FI	Finland	LT	Lithuania	SK	Slovakia
AT	Austria	FR	France	LU	Luxembourg	SN	Senegal
AU	Australia	GA	Gabon	LV	Latvia	SZ	Swaziland
AZ	Azerbaijan	GB	United Kingdom	MC	Monaco	TD	Chad
BA	Bosnia and Herzegovina	GE	Georgia	MD	Republic of Moldova	TG	Togo
BB	Barbados	GH	Ghana	MG	Madagascar	TJ	Tajikistan
BE	Belgium	GN	Guinea	MK	The former Yugoslav Republic of Macedonia	TM	Turkmenistan
BF	Burkina Faso	GR	Greece	ML	Mali	TR	Turkey
BG	Bulgaria	HU	Hungary	MN	Mongolia	TT	Trinidad and Tobago
BJ	Benin	IE	Ireland	MR	Mauritania	UA	Ukraine
BR	Brazil	IL	Israel	MW	Malawi	UG	Uganda
BY	Belarus	IS	Iceland	MX	Mexico	US	United States of America
CA	Canada	IT	Italy	NE	Niger	UZ	Uzbekistan
CF	Central African Republic	JP	Japan	NL	Netherlands	VN	Viet Nam
CG	Congo	KE	Kenya	NO	Norway	YU	Yugoslavia
CH	Switzerland	KG	Kyrgyzstan	NZ	New Zealand	ZW	Zimbabwe
CI	Côte d'Ivoire	KP	Democratic People's Republic of Korea	PL	Poland		
CM	Cameroon	KR	Republic of Korea	PT	Portugal		
CN	China	KZ	Kazakstan	RO	Romania		
CU	Cuba	LC	Saint Lucia	RU	Russian Federation		
CZ	Czech Republic	LI	Liechtenstein	SD	Sudan		
DE	Germany	LK	Sri Lanka	SE	Sweden		
DK	Denmark	LR	Liberia	SG	Singapore		
EE	Estonia						

5

10

FLYING DISK

15

TECHNICAL FIELD

This invention relates to toy flying disks.

BACKGROUND OF THE INVENTION

20 Toy flying disks, such as those sold under the tradename "FRISBEE", have existed for many years. These flying disks typically have a rigid saucer shaped body with a downturned peripheral lip. In use, the flying disk is sailed by throwing it with a flicking motion of the wrist to cause the disk to spin rapidly while in flight. The configuration of the disk during  
25 flight however is stagnant. Additionally, these types of disks are typically caught along the leading, peripheral edge, a task which is often difficult for small children. Furthermore, the disk may cause physical harm to small children not accustomed to catching the disk. This physical harm may come about from not  
30 properly catching the edge of the disk and thereby causing harm to the hand, or from missing the disk entirely which may result in the rigid disk colliding with the body or head of a child.

Soft flying disks have also been developed having a fabric disk-shaped center and a weighted peripheral edge in the form of a hollow fabric ring filled with weighted material, as disclosed in U.S. Patent Nos. 4,241,533, 4,223,473 and 5,078,637. These flying disks however tend to turn onto their sides during flight rather than flying level. These disks also have a stagnant, level configuration during flight due to centrifugal force upon the weighted peripheral edge. While these disks are not rigid, their weight may still cause harm to a child upon collision.

Accordingly, it is seen that a need remains for a flying disk which can be thrown for dynamic flight and which may be easily grasped by a small child without causing possible harm. It is to the provision of such therefore that the present invention is primarily directed.

#### SUMMARY OF THE INVENTION

In a preferred form of the invention a flying disk comprises a flexible, limp body having a top surface, a bottom surface and a peripheral rim. The body has an annular array of passages therethrough and a plurality of bumps projecting outwardly from the upper surface.

#### BRIEF DESCRIPTION OF THE DRAWING

Fig. 1 is a perspective view of a flying disk embodying principles of the invention is a preferred form.

Fig. 2 is a perspective view of the flying disk of Fig. 1 shown grasped within a hand prior to flight.

Fig. 3 is a perspective view of the flying disk of Fig. 1 shown being caught.

Fig. 4 is a sequence of perspective views of the flying disk of Fig. 1 showing the configuration of the flying disk during  
5 flight.

Fig. 5 is a perspective view of an alternative embodiment of the flying disk shown in Fig. 1.

Fig. 6 is a cross-sectional view of a portion of an alternative embodiment of the flying disk shown in Fig. 1.

10 Fig. 7 is a cross-sectional view of another alternative embodiment of the flying disk shown in Fig. 1.

Fig. 8 is a perspective view of another alternative embodiment of the flying disk shown in Fig. 1.

15 Fig. 9 is a top view of another alternative embodiment of the flying disk shown in Fig. 1.

Fig. 10 is a top view of another alternative embodiment of the flying disk shown in Fig. 1.

20

#### DETAILED DESCRIPTION

With reference next to the drawings, there is shown a flexible, limp flying disk 10 made of a soft, nonrigid, rubber. The disk 10 has a generally circular, central body portion 11 and an upturned, annular peripheral lip 12. The body portion 11 has  
25 a bottom surface 14 and top surface 15 having a multitude of bumps 16 thereon. A series of openings or passages 18 extend through the body portion 11. Preferably the openings 18 are aligned in an annular array and in a symmetric pattern with

respect to a bisecting diameter D. Also, the series of bumps 16 are preferably oriented in an annular array and in a symmetric pattern with respect to diameter D.

In use, the flying disk 10 is grasped about its peripheral lip 12, as shown in Fig. 2, and thrown with the same manual motion as conventional flying disks. As shown in Fig. 4, the thrown disk is typically imparted with a pair of symmetric, standing waves W which results from the flexibility of the disk, the generally even distribution of weight from center to peripheral edge, and the manual release of the disk, i.e. the disks takes on a wavy configuration during flight as opposed to the level configuration of prior art disks. The standing waves W in the spinning disk typically rotate about the spinning disk in the same direction as the direction of disk spin or rotation R, but at a much slower rate than that of the disk rotation R. This wavy, undulating configuration during flight gives the disk a dynamic flying characteristic which resembles the swimming pattern of sea creatures such as sting-rays. The height, width and rotation of the standing wave may be changed by the manner in which the disk is thrown.

The bumps 16 upon the top surface 15 of the disk provide lift to the disk while in flight due to the flow of air over the bump which creates an air foil effect. The openings 18 aid the disk in achieving a relative level flight path. Without such openings 18 the disk tends to tilt during flight causing it to veer off the intended flight path. The openings also allow air passing over the bumps to continue through the body to increase the lifting effect of the bumps.

As shown in Fig. 3, to catch the disk one needs only place a hand H in the flight path of the disk. As the disk collides with the hand it tends to fold upon itself and momentarily wrap about the hand. At this time the hand is closed to grasp the disk. This action differs from conventional rigid disks in that rigid disks tends to ricochet or bounce off the hand very quickly and therefore the hand must be closed at precisely the moment of contact. Conversely, disk 10 remains in intimate contact with the hand for an extended period of time rather than bouncing off the hand. Also, conventional disks are usually caught along the periphery of the leading edge of the disk since their bodies cannot be grasped from the top or bottom alone. The soft body of disk 10 however allows it to be folded and grasped from any direction along any part of the disk. A person may catch the disk by grasping the top, bottom or edge of the disk. It should be understood that the light, limp construction of the disk will not cause physical harm to a child, even if it should hit the child in the face.

With reference next to Fig. 5, a flying disk 20 in another preferred form is shown as an alternative to that shown in Figs. 1-4. Here, the disk 20 has a flexible, limp body 21 of a generally octangular shape. The body has an annular array of bumps 22 having a generally square shape rather than a rounded shape. The body also has four large openings 23 rather than many small openings.

With reference next to Fig. 8, a flying disk 40 in another preferred form is shown. Here, the disk 40 has a star-shaped body 41 having six arms 42 extending about an annular, inner lip

43 defining a central opening 44.

With reference next to Fig. 9, a flying disk 50 in another preferred form is shown. The disk 50 has a central opening 51 and an annular array of six openings 52. Here, the disk 50 has an annular array of bumps 53 extending radially from the central opening 51.

With reference next to Fig. 10, a flying disk 60 in another preferred form is shown. The disk 60 has a central portion 62 and a peripheral portion 63. The central portion 62 has three concentric annular arrays of bumps 64 which form a field of bumps having openings therebetween so as to have a spoke-like appearance. The peripheral portion 63 also has an annular array of bumps 65.

With reference next to Fig. 7, a flying disk 70 in another preferred form is shown. The disk 70 has a body 71 with a central, annular lip 72 having an upper portion 73 extending upwardly and a lower portion 74 extending downwardly. The disk 70 also has a peripheral lip 76 having an upper portion 77 and a lower portion 78. It is believed that the central lip 72 maintains the disk in the inclined angle at which it is thrown, i.e. preventing self-leveling of the disk in flight. Likewise, the lower portion 78 of peripheral lip 76 is believed to enhance the flying characteristics of the disk.

It should be understood that the disk bumps may be formed in most geometric shapes so long as the crown 25 is rounded so as to cause an even flow of air thereover. Also, it is believed that the size and number of bumps are not critical so long as they provide adequate lift. Also, it should be understood that

the size, shape and number of the disk openings are not critical so long as an even flow of air passes through the body and the body has adequate structure to enable the disk to be grasped. The shape of the disk is preferably circular, however other  
5 symmetric shapes may be employed. As such, the terms annular and disk used herein are not meant to be limited to circular or annular shapes, but are meant to include generally symmetric shapes such as stars, pentagons, heptagons, octagons, etc. Lastly, it is preferred that the disk include a peripheral lip  
10 to aid grasping and air flow about the periphery, however, this lip also is not critical to the invention.

Referring next to Fig. 6, the disk may also include dimples  
30 which extend from the bottom surface 14 of the disk body. Preferably, the dimples 30 are aligned with the bumps 16  
15 protruding from the top surface 15. It is believed that the dimples 30 provide a greater amount of lift to the disk during flight than the flat bottom surface.

It thus is seen that a toy flying disk is now provided which may be used for children for dynamic flight in a safe and easy  
20 to grasp manner. While this invention has been described in detail with particular references to the preferred embodiments thereof, it should be understood that many modifications, additions and deletions, in addition to those expressly recited, may be made thereto without departure from the spirit and scope  
25 of the invention as set forth in the following claims.

CLAIMS

1. A flying disk comprising a flexible, limp body having a top surface, a bottom surface and a peripheral rim, said body having an annular array of passages therethrough and a plurality of bumps projecting upwardly from said upper surface.

2. The flying disk of claim 1 wherein said plurality of bumps are arranged in an annular array.

3. The flying disk of claim 1 wherein said bumps extend radially from a center of said body.

4. The flying disk of claim 1 wherein said body has a plurality of dimples extending inwardly from said bottom surface.

5. The flying disk of claim 4 wherein said dimples are aligned with said bumps.

6. The flying disk of claim 1 wherein said passages are aligned symmetrically with respect to a diameter bisecting said body.

7. The flying disk of claim 1 wherein said peripheral rim has a lip projecting from a central portion.

8. The flying disk of claim 7 wherein said lip projects

upwardly from said central portion.

9. The flying disk of claim 8 wherein said lip also projects downwardly from said central portion.

10. The flying disk of claim 1 wherein said body has a central lip defining a central opening.

11. The flying disk of claim 10 wherein said lip extends upwardly from said central portion.

12. The flying disk of claim 11 wherein said lip also extends downwardly from said central portion.

13. A flying disk made of a soft, limp material and having an annular array of passages within a field of raised bumps.

14. The flying disk of claim 13 wherein said raised bumps are arranged in an annular array.

15. The flying disk of claim 14 wherein said bumps extend radially from a center of said flying disk.

16. The flying disk of claim 13 further comprising a field of dimples.

17. The flying disk of claim 15 wherein said dimples are aligned with said bumps.

18. The flying disk of claim 13 further comprising a peripheral lip.

19. The flying disk of claim 18 wherein said lip extends downwardly.

20. The flying disk of claim 19 wherein said lip also extends upwardly.

21. The flying disk of claim 13 further comprising a central lip defining a central opening.

22. The flying disk of claim 21 wherein said central lip extends upwardly.

23. The flying disk of claim 21 wherein said central lip extends downwardly.

24. A flying disk made of a soft, limp material having a top surface with an annular array of bumps.

25. The flying disk of claim 24 further comprising a plurality of passages extending through said disk.

26. The flying disk of claim 25 wherein said passages are oriented in an annular array.

27. The flying disk of claim 26 further comprising an upwardly extending peripheral lip.

**FIG. 1**

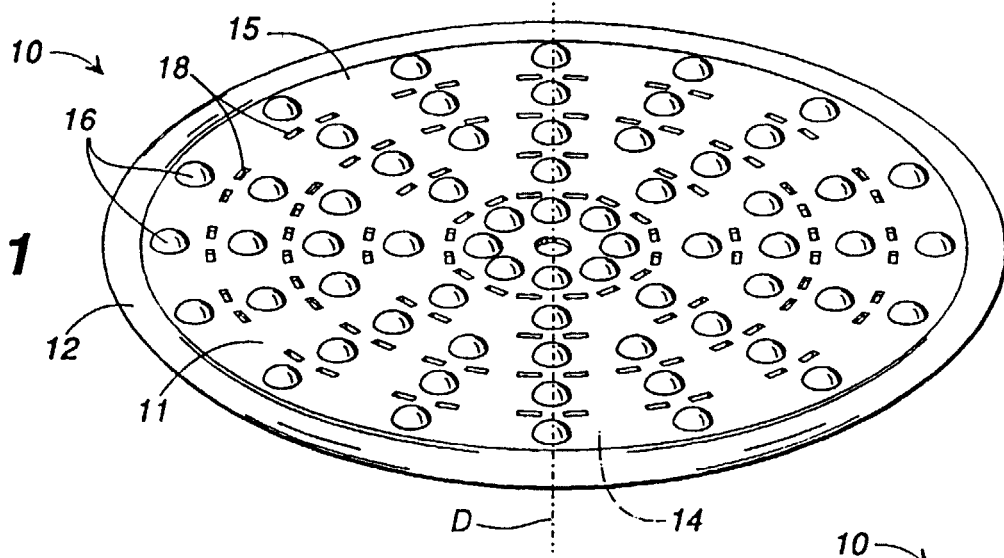

**FIG. 2**

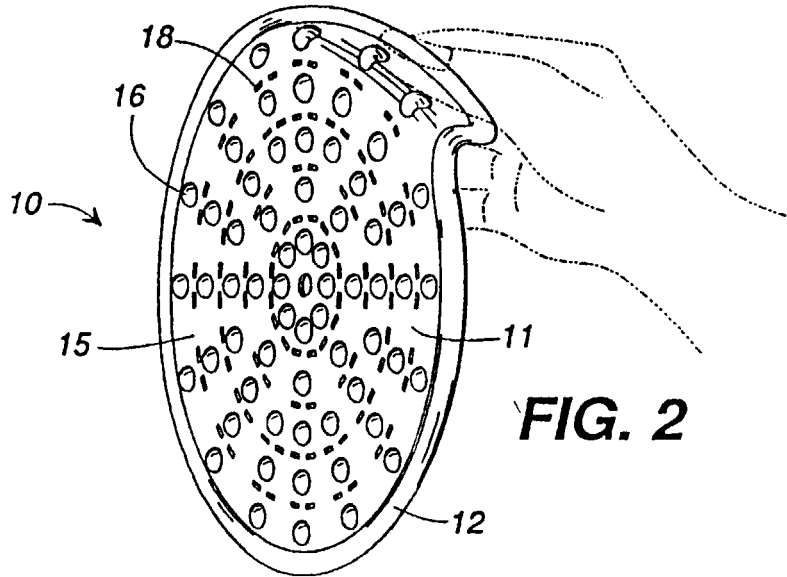

**FIG. 3**

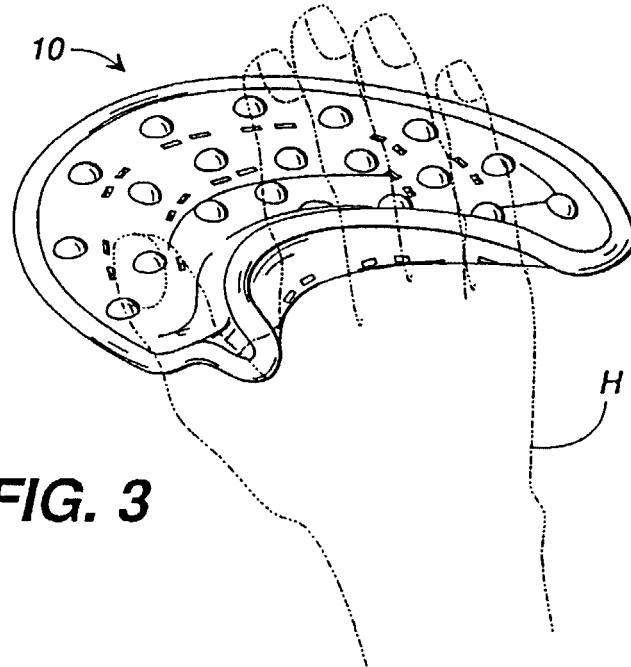

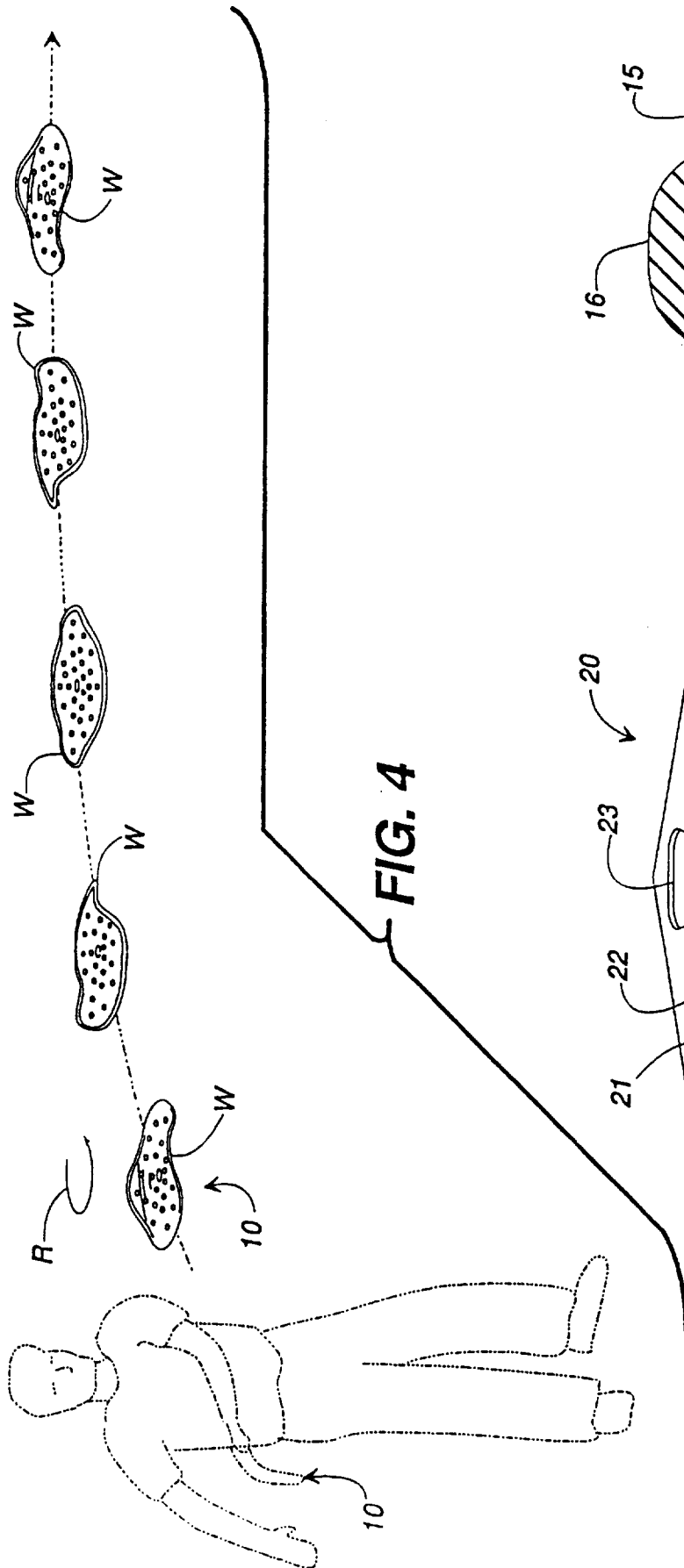

FIG. 4

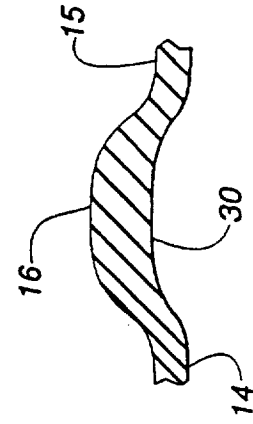

FIG. 6

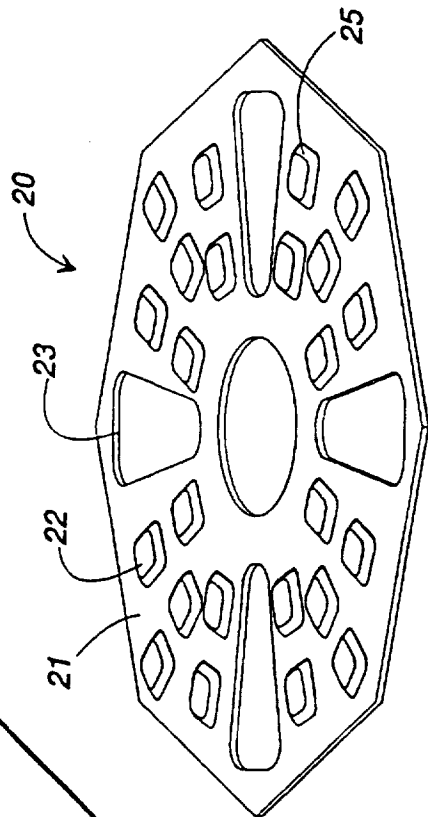

FIG. 5

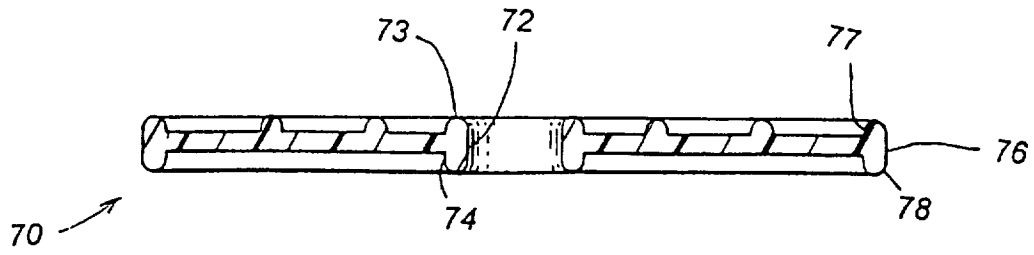

FIG. 7

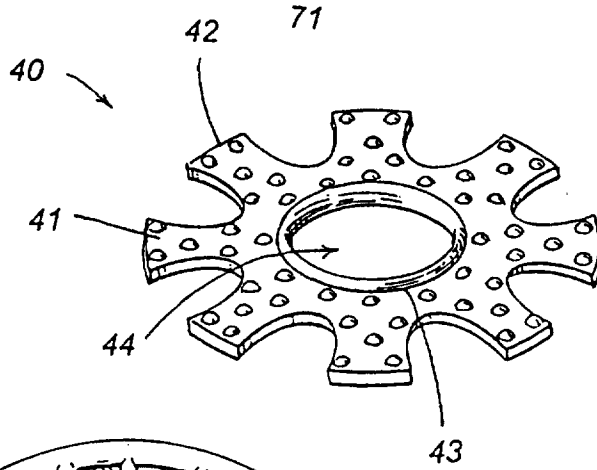

FIG. 8

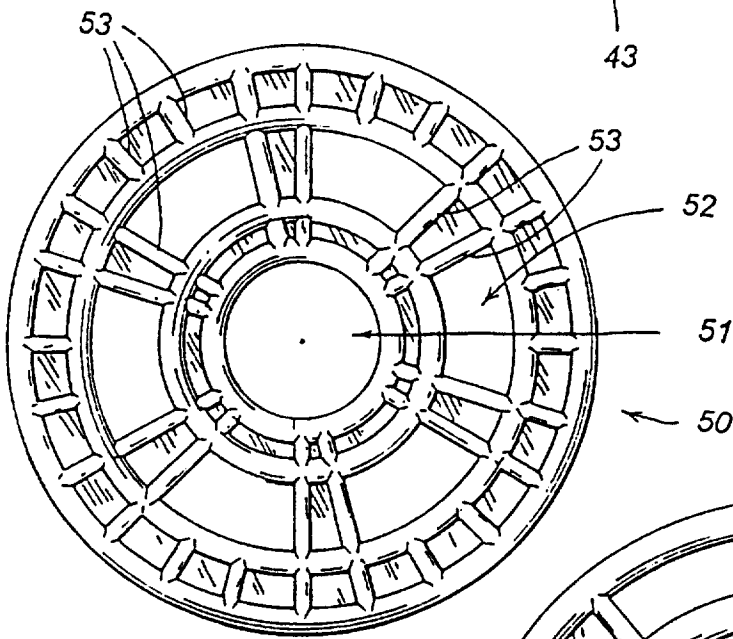

FIG. 9

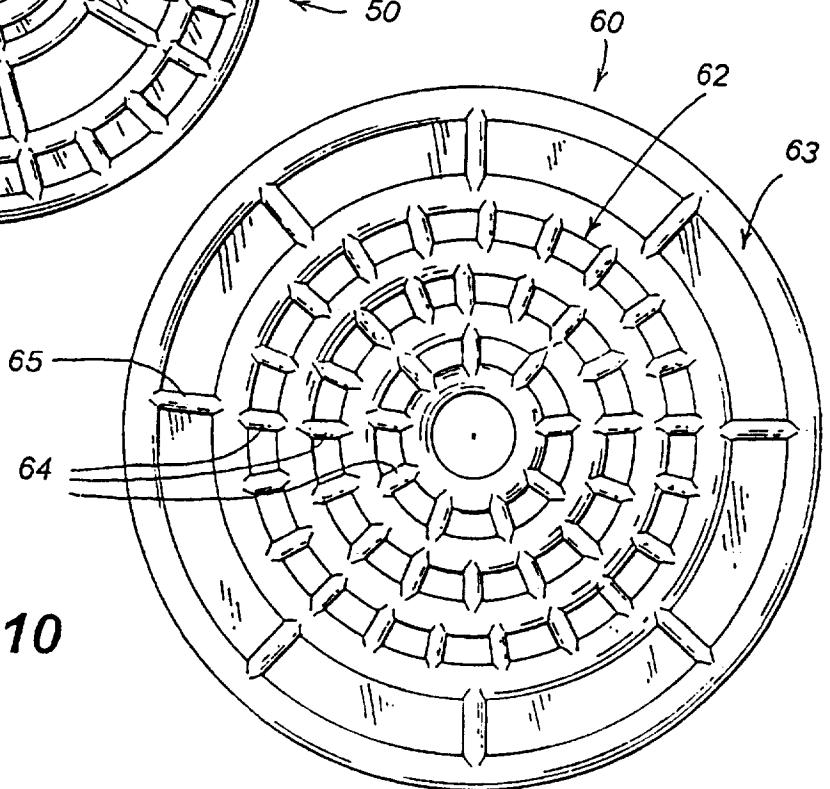

FIG. 10

**INTERNATIONAL SEARCH REPORT**

International application No.  
PCT/US97/15190

**A. CLASSIFICATION OF SUBJECT MATTER**  
 IPC(6) : A63H 27/00, 33/00  
 US CL : 446/46, 48; 473/588; D21/86  
 According to International Patent Classification (IPC) or to both national classification and IPC

**B. FIELDS SEARCHED**  
 Minimum documentation searched (classification system followed by classification symbols)  
 U.S. : 446/46, 48, 236, 255, 266; 473/486, 487, 588, 486; D21/82, 86

Documentation searched other than minimum documentation to the extent that such documents are included in the fields searched

Electronic data base consulted during the international search (name of data base and, where practicable, search terms used)  
 APS

**C. DOCUMENTS CONSIDERED TO BE RELEVANT**

Category*	Citation of document, with indication, where appropriate, of the relevant passages	Relevant to claim No.
X	US 5,476,405 A (CLAYBORNE) 19 December 1995, Fig. 1.	24
Y	US 5358440 A (ZHENG) 25 October 1994, entire document.	1-27
Y	US 4,302,901 A (PSYRAS) 01 Dec 1981, see figure 1.	1-3, 6-9, 13-20, 24-27
Y	US 5,340,347 A (YENERICH) 23 August 1994, Figs. 1-3.	4, 5
Y	US 3,828,466 A (GEIGER) 13 August 1974, raised bumps (15), and central opening (2).	4, 5, 10-12, 21-23
Y	US 4,944,707 A (SILVERGLATE) 31 January 1990, Fig. 3.	10-12, 21-23

Further documents are listed in the continuation of Box C.  See patent family annex.

* Special categories of cited documents:	"T" later document published after the international filing date or priority date and not in conflict with the application but cited to understand the principle or theory underlying the invention
"A" document defining the general state of the art which is not considered to be of particular relevance	"X" document of particular relevance; the claimed invention cannot be considered novel or cannot be considered to involve an inventive step when the document is taken alone
"E" earlier document published on or after the international filing date	"Y" document of particular relevance; the claimed invention cannot be considered to involve an inventive step when the document is combined with one or more other such documents, such combination being obvious to a person skilled in the art
"L" document which may throw doubts on priority claim(s) or which is cited to establish the publication date of another citation or other special reason (as specified)	"&" document member of the same patent family
"O" document referring to an oral disclosure, use, exhibition or other means	
"P" document published prior to the international filing date but later than the priority date claimed	

Date of the actual completion of the international search 06 OCTOBER 1997	Date of mailing of the international search report 10 NOV 1997
--	---

Name and mailing address of the ISA/US Commissioner of Patents and Trademarks Box PCT Washington, D.C. 20231 Facsimile No. (703) 305-3230	Authorized officer <i>Laura Fossum</i> LAURA FOSSUM Telephone No. (703) 308-2678
--	---

## INTERNATIONAL SEARCH REPORT

International application No.  
PCT/US97/15190

C (Continuation). DOCUMENTS CONSIDERED TO BE RELEVANT		
Category*	Citation of document, with indication, where appropriate, of the relevant passages	Relevant to claim No.
Y	US 4,023,805 A (SHERRILL) 17 May 1977, note the upwardly extending portion (4).	4, 5
A	US 5,261,846 A (HANNA) 16 November 1993, entire document.	1-27