

(No Model.)

2 Sheets—Sheet 1.

G. ALBERT.

CLOTH MEASURING AND TESTING MACHINE.

No. 304,591.

Patented Sept. 2, 1884.

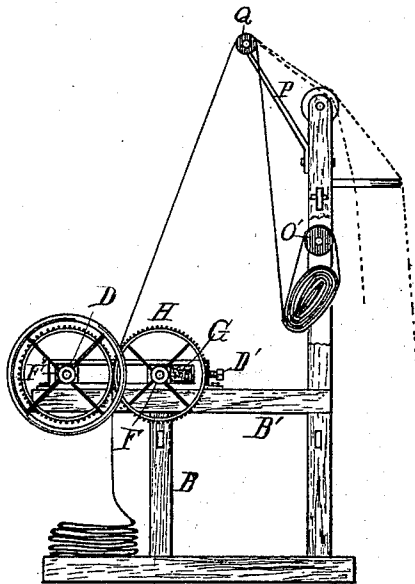

Fig. 1.

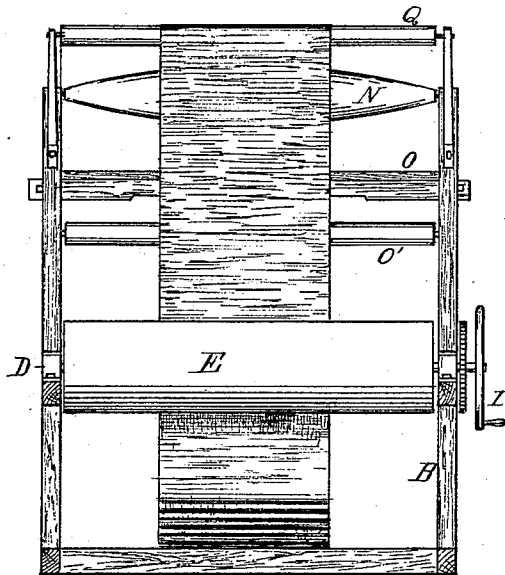

Fig. 2.

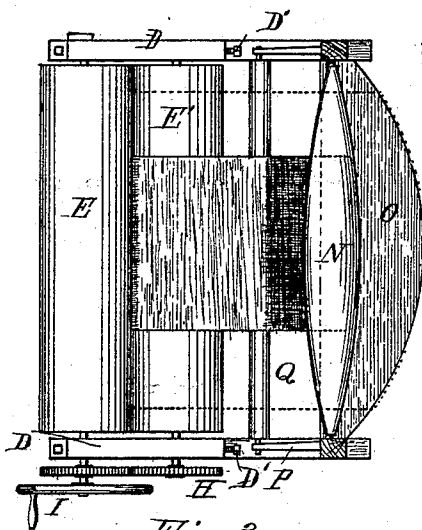

Fig. 3.

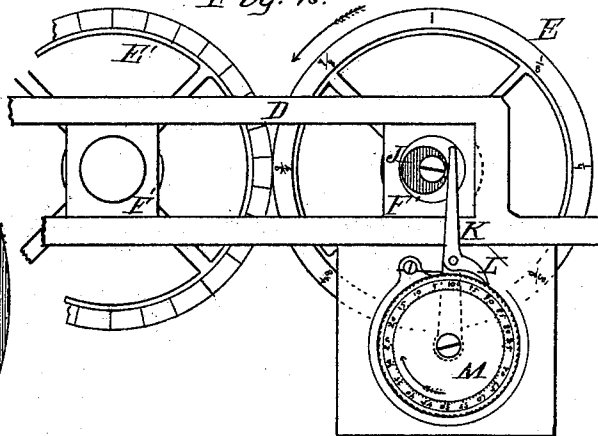

Fig. 4.

WITNESSES:

C. J. Bailey
C. D. Zerk

INVENTOR:

George Albert
By *J. D. Zerk*
Attorney.

(No Model.)

2 Sheets—Sheet 2.

G. ALBERT.

CLOTH MEASURING AND TESTING MACHINE.

No. 304,591.

Patented Sept. 2, 1884.

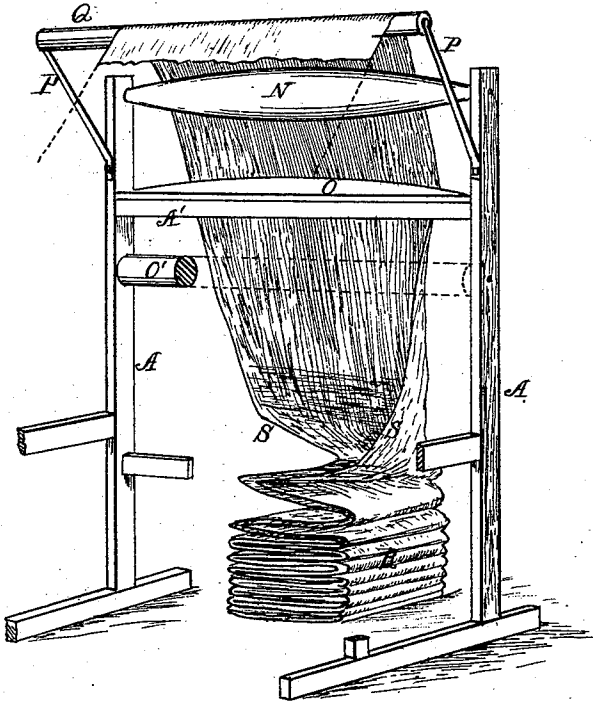

Fig. 5.

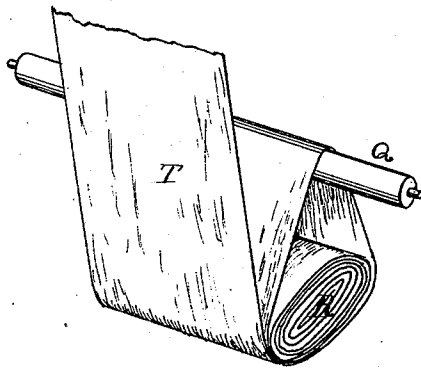

Fig. 6.

WITNESSES:

O. J. Bailey
C. D. Zerk

INVENTOR:

George Albert
By *C. D. Zerk* Attorney.

UNITED STATES PATENT OFFICE.

GEORGE ALBERT, OF CINCINNATI, OHIO.

CLOTH MEASURING AND TESTING MACHINE.

SPECIFICATION forming part of Letters Patent No. 304,591, dated September 2, 1884.

Application filed July 13, 1883. (No model.)

To all whom it may concern:

Be it known that I, GEORGE ALBERT, of Cincinnati, in the county of Hamilton and State of Ohio, have invented a new and useful Improvement in Cloth Measuring and Testing Machines, which improvement is fully set forth in the following specification and accompanying drawings, in which—

Figure 1 is an end view of the cloth measuring and testing machine. Fig. 2 is a front view of the same. Fig. 3 is a top view; Fig. 4, enlarged end view of a section of the frame, the rolls, and the measuring device. Fig. 5 is a perspective elevation of the rear part of the frame, showing method of opening and examining double-width goods on the machine; and Fig. 6, perspective view of the bolt-suspending roll having a bolt thereon ready for unwinding.

The object of the present invention is to provide a cheap, simple, and easily-operated machine for testing or examining cloth, or for measuring the same. It also provides a means for unwinding the cloth while being measured, and it is also so arranged that double-width goods can be taken from the piece and automatically spread and conducted to and through the measuring-rolls without any manipulation by hand, all of which will now be set forth in detail.

In the accompanying drawings, A A represent two posts of suitable height, having cross-beams A' A'.

B B are two short posts placed forward of the high post A, which support the horizontal beams B' B', which project forward from the rear posts, A A. These posts A B are framed into a suitable base, C, of sufficient strength to rigidly maintain the structure and mechanism. Each horizontal beam B' has mounted thereon, near the forward end, a metallic slotted guide-block, D, having at one end a screw-threaded bolt, D'.

E E' are two cylinders or rollers having suitable journals at each end, which pass through the sliding boxes F F' in the guide-blocks. The journal-box F is designed to slide in the guide-block horizontally, and interposed between it and the end of the screw-threaded bolt D' is an elastic cushion, G. The other journal-box, F', is also placed in the guide-

block, so that it will slide; but in operation said box rests against the head or end of the guideway. When, therefore, the screw-threaded bolts D' are forced up against the cushions G, the two cylinders are moved snugly together. The cylinder-journals carry pinions H at one end, which mesh into each other, so that the movements of the two cylinders are synchronous with each other. The elastic cushions behind the sliding journal-boxes F permit goods of various thicknesses to pass down between the rollers or cylinders. The journal of the stationary cylinder E, at one end, in any convenient way, and directly or intermediately, is provided with a crank, I, by means of which the machine is operated. The opposite end of this shaft or journal has an eccentric or cam, J, which is designed to operate this end of a pawl-lever, K, the pawl L of which actuates the ratchet-wheel M, which latter has its face properly graded and numbered, so that the operator can read the indications thereon and determine the number of revolutions made by the cylinders or calculate the quantity of goods which has passed through the rollers. In practice I prefer to have each cylinder exactly one yard in circumference, so that each rotation of the cylinder will cause the pawl L to move forward the ratchet-wheel one notch. This arrangement, therefore, only provides for measuring one or more yards, without fractions. To indicate the fractions of a yard, I divide the end of the cylinder E into eighths, as shown in Fig. 4. The upper end of the rear posts, A A, has a peculiarly-shaped roller, N, extending from one to the other. This roller is enlarged centrally, or is made convex from end to end, as shown. Below this roller, and secured to the posts or to the beam A, is a horizontal curved guide-board, O, with the curve projecting or extending rearwardly. The arc of this guide-board is preferably smaller than the arc of the face of the roller N from end to end.

P P are two arms projecting upwardly from the rear posts, A, so that they extend above the tops of said posts and incline forwardly. A roller, Q, is journaled to these arms. Below the curved guide-board O is also a similar roller, O', journaled to the posts, and both these rollers, as well as the roller N and the

curved guide-board, serve important purposes in the manipulation of the goods, as will now be shown. The primary object of the curved guide-board O is to open the fold of double-width goods as it is taken from the piece and fed through the machine, and the face of the roller N, being less curved, serves to more readily adapt the wide goods to the straight roll Q.

I will now first describe the operation of examining and measuring double-width goods. As shown more fully in Fig. 5, the piece of cloth R is laid on the floor, or on a truck on the rear side of the machine, with the end toward the machine. The goods, being double width, was folded longitudinally before being baled, as in R; therefore the selvage-edges S are on one end of the bale. It is a slow and tedious process to take the goods from the bale by hand and measure the same, and after this is done it is necessary to again go over the same piece to test it and examine the entire surface to discover the defects. To take the goods from the bale, therefore, I place the selvage end of the bale toward the machine, and place the end of the cloth over the guide-board O and rolls N Q, and conduct it thence down to and through between the measuring-cylinders E E'. The curved guide-board O and convex roller N open the fold and prevent the edges of the goods from lapping as the cylinders E E' draw the goods from the bale. The operator stands in front of the crank I, and the goods, as it passes from the top roll, Q, to the cylinders E E', is in full view of the inspector, who examines every foot of the goods as it passes to the cylinders. The cylinders being self-registering, the operator is enabled to stop the machine at any point and mark the edge of the goods where imperfections are found. Thus the two operations of measuring and examining are both performed at the same time, and, in addition, it is perfectly adapted to double-width as well as to single-width goods. Single-width goods are rolled up instead of being folded, as with double-width cloth, and it is therefore necessary to place the bolt in such a position that it will revolve, while the cyl-

inders draw on the end of the goods. For this purpose I have provided the roll O'. To place a bolt of cloth, R, of single width thereon, I loosen the end of the goods on the bolt and place the end T around the roll O', so that the bolt R hangs on the roll O'. It is therefore unrolled as the end T is drawn upward, as shown more fully at Fig. 6. Thus the machine is fully adapted for measuring and testing or examining the goods at one operation, and this applies to double as well as to single width goods.

What I claim as new is—

1. In a cloth-measuring machine, the cylinders E E', of equal size, working synchronously by means of the pinions H, in combination with the slotted guide-blocks at each end, having therein sliding journal-boxes, to which said cylinders are journaled, so as to adjust the same, substantially as herein shown.

2. In a cloth-measuring machine, the cylinders E E', of equal size, one having stationary bearings and the other capable of being moved to or from the first, having on the end of the stationary cylinder a cam or eccentric, in combination with a pawl and lever, and indicator or revolving dial-plate for registering the movement of the cylinders, substantially as herein set forth.

3. In a cloth measuring and testing machine, the combination of the measuring-cylinders E E', having at one end a registering device, with the elevated roll Q, the convex roll N, and the curved guide-board O, substantially as herein set forth.

4. In a cloth measuring and testing machine, the combination of the measuring-cylinders E E', having at one end a registering device, with the elevated roll Q and the bolt-suspending roll O', substantially as herein set forth.

In testimony that I claim the foregoing I have hereunto set my hand, this 21st day of June, 1883, in the presence of witnesses.

GEORGE ALBERT.

Witnesses:

J. S. ZERBE,
C. SUGENHEIM.