

[54] **PERMUTATION LOCK**
 [76] Inventor: **Gisela Lindner**, P.O. Box
 Friedrichstrasse 47, 586 Iserlohn,
 Germany

3,411,330	11/1968	Atkinson.....	70/288 X
3,434,314	3/1969	Atkinson.....	70/312 X
3,597,945	8/1971	Feinberg.....	70/318 X
3,707,861	1/1973	Lindner.....	70/313 X

[22] Filed: **Aug. 21, 1972**

FOREIGN PATENTS OR APPLICATIONS

207,684 12/1923 Great Britain..... 70/314

[21] Appl. No.: **282,569**

Primary Examiner—Albert G. Craig, Jr.

[30] **Foreign Application Priority Data**
 Aug. 21, 1971 Germany..... 2142065

[57] **ABSTRACT**

[52] U.S. Cl. **70/74, 70/312**
 [51] Int. Cl. **E05b 65/52**
 [58] Field of Search 70/2, 3, 4, 74, 75, 288,
 70/312, 314, 315, 316, 317, 318, 319

A permutation lock with a permutation set-over device, which comprises a setting handle carrying marks and being rotatably mounted relative to an annular-shaped locking disc. The locking disc having a feed-in opening for entering of a lock tongue of a sliding bolt at a correctly set permutation, and said sliding bolt is blocked against any longitudinal displacement upon a falsely set permutation.

[56] **References Cited**
UNITED STATES PATENTS
 86,908 2/1869 Cole et al 70/288 X
 1,782,212 11/1930 Recker..... 70/288 X

3 Claims, 11 Drawing Figures

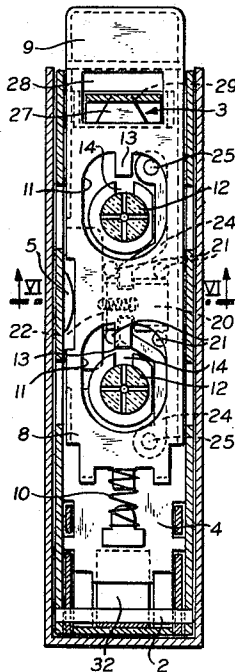

FIG. 5.

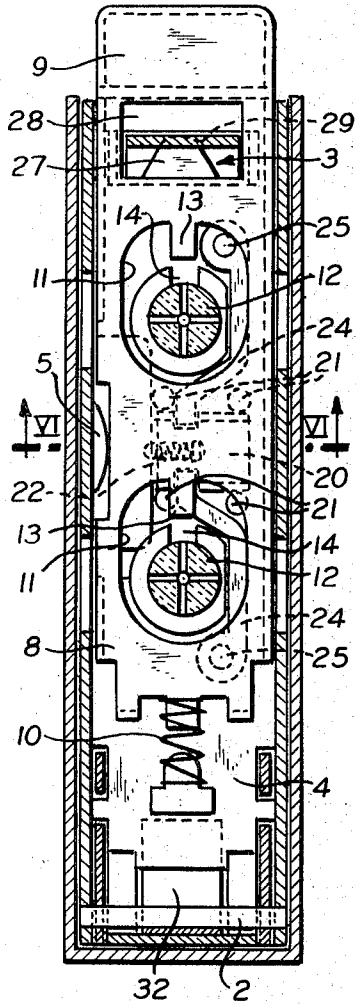

FIG. 9.

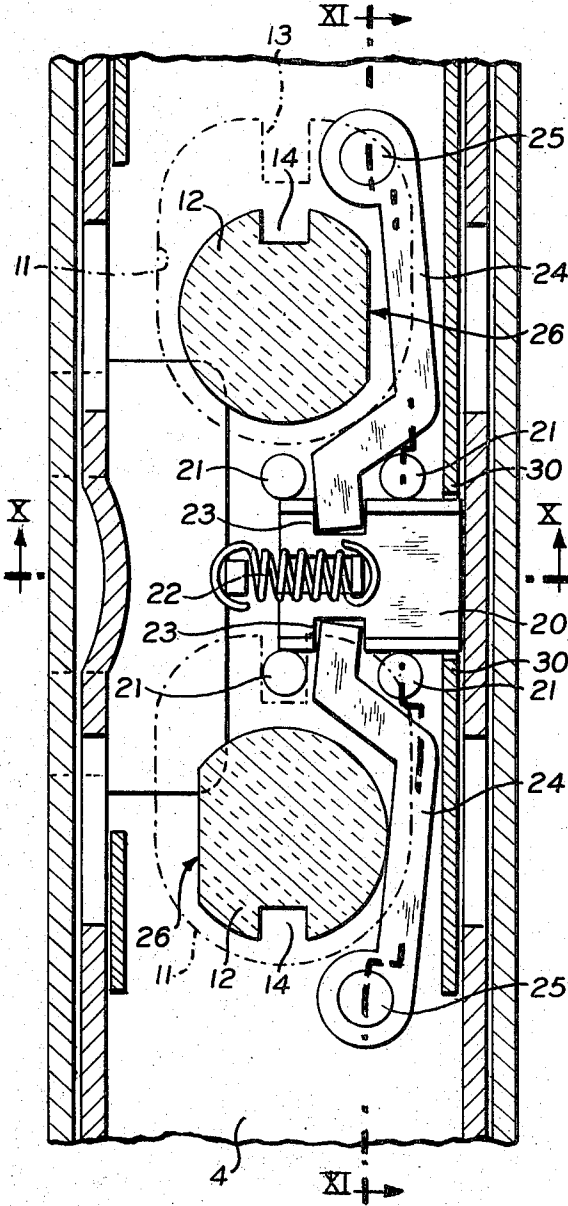

FIG. 11.

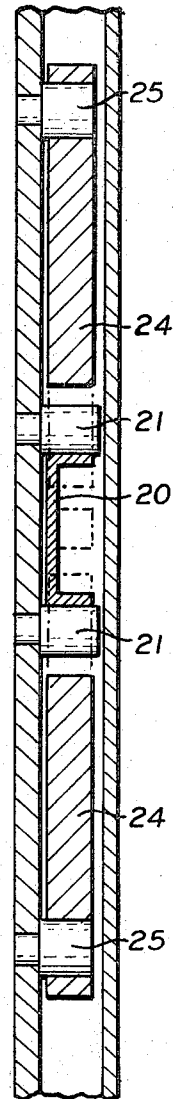

FIG. 6.

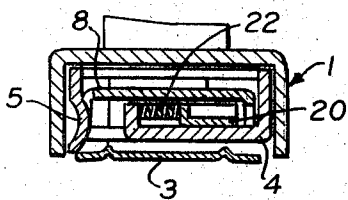
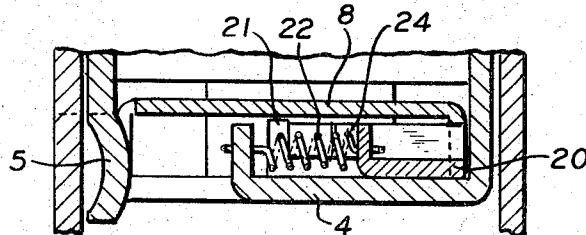

FIG. 10.



PERMUTATION LOCK

The present invention relates to permutation lock with a permutation-set over device, in which a setting handle carrying marks is rotatably provided for the variation of the permutation relative to an annular locking disc, which locking disc has a feed opening for entry of a locking tongue of the sliding bolt in case of a correctly set permutation.

In these known permutation locks, a heavily weighing drawback exists in accordance with experience, since it occurs rather often that the set permutation varies unintentionally, so that opening difficulties occur, since the set self-permutation cannot be recognized. This danger of the self-variation is conditioned by experience, since it is necessary, to couple together the locking disc of the lock with the setting handle carrying the marks by means of stops. If in case of an error in the handling, the locking tongue of the sliding bolt shuts towards the periphery of the locking disc, the latter is secured due to friction and the rotation of the number disc (setting handle), thus an adjustment of the set permutation occurs.

It is one object of the present invention to provide a permutation lock, which avoids this drawback in reliable manner with slight expenses.

It is another object of the present invention to provide a permutation lock such, that in accordance with the present invention the sliding bolt is blocked in case of falsely-set permutation against any longitudinal displacement. The play-free blocking is brought about such, that the sliding bolt, in case of a correctly-set permutation, enters the releasing position.

The sliding bolt is thereby spring biased in the direction of its releasing position and the peripheral face of the locking disc has a flat portion which is disposed opposite the control lever, in case of a correctly-set permutation.

The locking slide is preferably guided in the housing and enters a locking opening of the sliding bolt.

Since advantages of this formation reside in the first place in the fact, that with exception of the opening position, the sliding bolt is blocked play-free, so that also upon loading the same its locking tongue cannot be effective in retarding the locking disc. By this arrangement always a free rotation of the handle and of the locking gear is assured. A further advantageous effect results insofar, that due to the locking also a sensing of the opening position is prevented. Thereafter, also still structural advantages result, in particular an advantageous friction coupling between the handle and the locking disc is made possible.

With these and other objects in view, which will become apparent in the following detailed description, the present invention, which is shown by example only, will be clearly understood, in connection with the accompanying drawings, in which:

FIG. 1 is a front elevation of the permutation closure designed in accordance with the present invention as a map lock, as well as of the closing hasp;

FIG. 2 is a side elevation of the permutation closure shown in FIG. 1;

FIG. 3 is a longitudinal section along the lines III—III of FIG. 1 in closed position at an enlarged scale;

FIG. 4 is similarly a longitudinal section; however, in open position of the permutation lock;

FIG. 5 is a section along the lines V—V of FIG. 3;

FIG. 6 is a section along the lines VI—VI of FIG. 5.

FIG. 7 is a section through the locking disc in addition to the handle at a still larger scale;

FIG. 8 is a section along the lines VIII—VIII of FIG. 7;

FIG. 9 is a part section with the sliding bolt in locking position (closing position);

FIG. 10 is a cross section along the lines X—X of FIG. 9; and

FIG. 11 is a longitudinal section along the lines XI—XI of FIG. 9.

Referring now to the drawings, the lock housing 1 comprises a box having a housing cover 1' and the longitudinal side walls 1'', as well as the cross side walls 1''', which box is tiltingly hinged by means of the pivot pin 2 on the lock securing plate 3. The box of the lock housing 1 is closed up on the bottom side by a cup shaped bottom part 4. In the one longitudinal side wall 1'' a holding tongue 5 with a recess 6 forming a holding tongue 5 is provided, in which recess 6 the closing hasp 7 can be inserted. During swinging in of the lock housing 1 into engagement on the securing plate 3 (FIG. 2), the hasp is secured.

The pressure key 9 formed by extension of the sliding bolt 8 emerges at the upper cross side wall 1''' from the lock housing 1. The sliding bolt 8 is mounted in the lock housing 1 for longitudinal displacement and stands biased by a pressure spring 10, which advances the sliding bolt 8. The sliding bolt 8 has two window openings 11 through which each of the locking discs 12 passes. In the window openings 11 a locking tongue 13 each is provided, which point in the same direction and for which in the locking disc a feeding opening 14 each is provided (FIG. 5).

The locking discs 12 are mounted in the housing bottom wall 4 by means of a pivot 12' and enter with a projecting band 15 into a recess 16 of the hat-shaped handle 17. The latter has at the edge of the hat 17 the marking signs necessary for the permutation, by example, the numbers of 0 to 9 (FIG. 8), which are visible from the outside in the window 31.

In order to obtain a sufficient friction closure, the band 15 is equipped with crosswise slots 18, which cause an elasticity of the band, so that the latter can be inserted into the recess 16 in a pressure seat. Accordingly the handle 17 can be turned only upon surpassing the holding force relative to the locking disc 12. As a mounting assistance for the setting of the permutation serves a gearing 19 disposed at the edge of the number disc, which provides the setting marks relative to the feeding slot 14.

A locking slide 20, which is coordinated to the sliding bolt 8, is mounted on the housing bottom 4, which locking slide 20 is movable due to guide pins 21 crosswise to the moving direction of the sliding bolt 8. The locking slide 20 is under effect of a spring 22. Furthermore, the locking slide 20 has two oppositely disposed recesses 23, in which the ends of a controlled lever 24 each enter. The latter are mounted on immovable pins 25 swingably at the bottom 4 of the housing. The arm of each control lever 24 enters with its edge conventionally the face of the control disc 12 (FIG. 9). The latter has a flat portion 26 disposed parallel to the feeding opening 13, which makes possible a swinging of the particular control lever.

In the longitudinal side wall of the U-shaped profile sliding bolt 8 a locking opening 30 is cut out, in which by means of the control levers 24 (in case of a multiple number thereof in closing position of the lock by at least one thereof) the locking slide 20 is preferably inserted play-free and thereby the sliding bolt 8 is blocked.

The sliding bolt 8 has a tongue 27 which is disposed at the level of an opening 28 of the housing bottom 4 and which, as can be ascertained from FIGS. 3 and 4, for the closing position jumps into a closing eye 29 of the securing plate 3.

A spreading spring 32 is also provided, in order to simplify the opening and release, respectively, of the hasp 7.

The operation of the above-described permutation lock is as follows:

In case of a closed closure (FIG. 2) by setting of the characteristic number, the lock is put into operational possibility thus, by pushing inwardly the pressure key 9 in arrow direction A (FIG. 2) the sliding bolt 8 is displaced. The locking tongues 13 enter thereby into the feeding openings 14, so that the required stroke for releasing the eye 29 is brought about. The locking slide 20 is withdrawn during this function by the pull spring 22, from the blocking position (FIG. 9) and the locking opening 30, respectively.

The closing hasp 7 can now be released. The closing of the closure takes place accordingly in a reversed order.

For variation of the set permutation number it is required, at first to set the opening permutation characteristic number, which is brought about by rotation of the handle 17, which is turned as long, until the corresponding numbers appear in the view windows 31. Thereafter, the pressure key 9 is operated and retained. One can then secure by overcoming the friction force the locking disc and turn the number disc, so that a selected variation of the characteristic number occurs, which maintains thereafter validity.

In order to avoid that the clamping of the locking discs during pressing down the key 9 a variation of the permutation is obtained, the blocking bolt 20 is always in the locking opening 30 in blocking position, so that the sliding bolt 8 is blocked in case of a falsely set per-

mutation against any longitudinal displacement (FIG. 9).

The control levers 24 releasing the locking bolt 20 cooperate with the periphery of the locking slide 12, in which the flattened position 26 thereof is disposed opposite the control lever in case of a correctly set permutation. The control levers 24 support themselves then on the flat portion 26 and make possible the spring return of the locking slide.

While I have disclosed one embodiment of the present invention, it is to be understood, that this embodiment is given by example only, and not in a limiting sense.

I claim:

1. A permutation lock with a permutation set-over device, comprising

a setting handle carrying marks being rotatably mounted relative to an annular-shaped locking disc,

said locking disc having a feed-in opening for entering of a lock tongue of a sliding bolt at a correctly set permutation,

said sliding bolt being blocked against any longitudinal displacement upon false set permutation,

a locking slide means for blocking said sliding bolt, and

a control lever operatively connected to said locking slide and cooperating together with a peripheral face of said locking disc such, that said locking slide means enters into a position releasing said sliding bolt by said correctly set permutation.

2. The permutation lock, as set forth in claim 1 wherein

said locking slide means is spring-biased in direction of its releasing position,

the peripheral face of said locking disc has a flattened portion, and

said flattened portion is disposed opposite said control lever upon said correctly set permutation.

3. The permutation lock, as set forth in claim 1, wherein

said locking slide means is guided in said housing and enters into a lock opening of said sliding bolt.

* * * * *

50

55

60

65