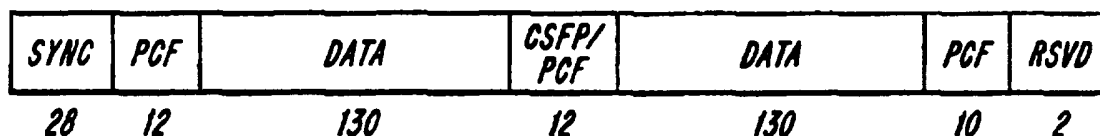




INTERNATIONAL APPLICATION PUBLISHED UNDER THE PATENT COOPERATION TREATY (PCT)

<p>(51) International Patent Classification <sup>6</sup> : <b>H04Q 7/38, 7/22, H04B 7/26</b></p>	<p><b>A2</b></p>	<p>(11) International Publication Number: <b>WO 97/15166</b> (43) International Publication Date: 24 April 1997 (24.04.97)</p>
<p>(21) International Application Number: PCT/US96/16696 (22) International Filing Date: 18 October 1996 (18.10.96) (30) Priority Data: 08/544,835 18 October 1995 (18.10.95) US (71) Applicants: TELEFONAKTIEBOLAGET LM ERICSSON [SE/SE]; S-126 25 Stockholm (SE). ERICSSON INC. [US/US]; 7001 Development Drive, P.O. Box 13969, Research Triangle Park, NC 27709 (US). (72) Inventor: RATH, Alex, Krister, 805-A5 Park Ridge Road, Durham, NC 27713 (US). (74) Agents: GRUDZIECKI, Ronald, L. et al.; Burns, Doane, Swecker &amp; Mathis, L.L.P., P.O. Box 1404, Alexandria, VA 22313-1404 (US).</p>		<p>(81) Designated States: AL, AM, AT, AU, AZ, BA, BB, BG, BR, BY, CA, CH, CN, CU, CZ, DE, DK, EE, ES, FI, GB, GE, HU, IL, IS, JP, KE, KG, KP, KR, KZ, LC, LK, LR, LS, LT, LU, LV, MD, MG, MK, MN, MW, MX, NO, NZ, PL, PT, RO, RU, SD, SE, SG, SI, SK, TJ, TM, TR, TT, UA, UG, UZ, VN, ARIPO patent (KE, LS, MW, SD, SZ, UG), Eurasian patent (AM, AZ, BY, KG, KZ, MD, RU, TJ, TM), European patent (AT, BE, CH, DE, DK, ES, FI, FR, GB, GR, IE, IT, LU, MC, NL, PT, SE), OAPI patent (BF, BJ, CF, CG, CI, CM, GA, GN, ML, MR, NE, SN, TD, TG).</p> <p><b>Published</b> <i>Without international search report and to be republished upon receipt of that report.</i></p>

(54) Title: DISCRIMINATING BETWEEN CHANNELS IN WIRELESS COMMUNICATION SYSTEMS



(57) Abstract

A method and device are provided for encoding superframe phase (SFP) and packer channel feedback (PCF) information into a coded superframe phase/packet channel feedback (CSFP/PCF) field. More particularly, the channel coding method is directed to distinguishing among a DCCH, a DTC and a packet data channel (PDCH). An exclusive-OR function may be performed on the logical value of the SFP before transmittal. In this way, transmitted SFP values exhibit a generally decreasing trend on a PDCH.

**FOR THE PURPOSES OF INFORMATION ONLY**

Codes used to identify States party to the PCT on the front pages of pamphlets publishing international applications under the PCT.

AM	Armenia	GB	United Kingdom	MW	Malawi
AT	Austria	GE	Georgia	MX	Mexico
AU	Australia	GN	Guinea	NE	Niger
BB	Barbados	GR	Greece	NL	Netherlands
BE	Belgium	HU	Hungary	NO	Norway
BF	Burkina Faso	IE	Ireland	NZ	New Zealand
BG	Bulgaria	IT	Italy	PL	Poland
BJ	Benin	JP	Japan	PT	Portugal
BR	Brazil	KE	Kenya	RO	Romania
BY	Belarus	KG	Kyrgystan	RU	Russian Federation
CA	Canada	KP	Democratic People's Republic of Korea	SD	Sudan
CF	Central African Republic	KR	Republic of Korea	SE	Sweden
CG	Congo	KZ	Kazakhstan	SG	Singapore
CH	Switzerland	LI	Liechtenstein	SI	Slovenia
CI	Côte d'Ivoire	LK	Sri Lanka	SK	Slovakia
CM	Cameroon	LR	Liberia	SN	Senegal
CN	China	LT	Lithuania	SZ	Swaziland
CS	Czechoslovakia	LU	Luxembourg	TD	Chad
CZ	Czech Republic	LV	Latvia	TG	Togo
DE	Germany	MC	Monaco	TJ	Tajikistan
DK	Denmark	MD	Republic of Moldova	TT	Trinidad and Tobago
EE	Estonia	MG	Madagascar	UA	Ukraine
ES	Spain	ML	Mali	UG	Uganda
FI	Finland	MN	Mongolia	US	United States of America
FR	France	MR	Mauritania	UZ	Uzbekistan
GA	Gabon			VN	Viet Nam

-1-

**DISCRIMINATING BETWEEN CHANNELS  
IN WIRELESS COMMUNICATION SYSTEMS****BACKGROUND**

5 Applicants' invention relates to electrical telecommunication, and more particularly to wireless communication systems, such as cellular and satellite radio systems, for various modes of operation (analog, digital, dual mode, etc.), and access techniques such as frequency division multiple access (FDMA), time division multiple access (TDMA), code division multiple access (CDMA), and hybrid  
10 FDMA/TDMA/CDMA. The invention is directed to enhancing timing, decoding and encoding aspects of electrical communication in wireless communication systems.

A description follows which is directed to environments in which this invention may be applied. This general description is intended to provide a general overview of known systems and the associated terminology so that a better understanding of the  
15 invention can be obtained.

In North America, digital communication and multiple access techniques such as TDMA are currently provided by a digital cellular radiotelephone system called the digital advanced mobile phone service (D-AMPS), some of the characteristics of which are specified in the interim standard TIA/EIA/IS-54-B, "Dual-Mode Mobile  
20 Station-Base Station Compatibility Standard", published by the Telecommunications Industry Association and Electronic Industries Association (TIA/EIA). The TIA/EIA/IS-54-B standard is incorporated by reference in this application. Because of a large existing consumer base of equipment operating only in the analog domain with frequency-division multiple access (FDMA), TIA/EIA/IS-54-B is a dual-mode  
25 (analog and digital) standard, providing for analog compatibility together with digital communication capability. For example, the TIA/EIA/IS-54-B standard provides for both FDMA analog voice channels (AVC) and TDMA digital traffic channels (DTC). The AVCs and DTCs are implemented by frequency modulating radio carrier signals, which have frequencies near 800 megahertz (MHz) such that each radio channel has a  
30 spectral width of 30 kilohertz (KHz).

-2-

In a TDMA cellular radiotelephone system, each radio channel is divided into a series of time slots, each of which contains a burst of information from a data source, e.g., a digitally encoded portion of a voice conversation. The time slots are grouped into successive TDMA frames having a predetermined duration. The number  
5 of time slots in each TDMA frame is related to the number of different users that can simultaneously share the radio channel. If each slot in a TDMA frame is assigned to a different user, the duration of a TDMA frame is the minimum amount of time between successive time slots assigned to the same user.

The successive time slots assigned to the same user, which are usually not  
10 consecutive time slots on the radio carrier, constitute the user's digital traffic channel, which may be considered a logical channel assigned to the user. As described in more detail below, digital control channels (DCCs) can also be provided for communicating control signals, and such a DCC is a logical channel formed by a succession of usually non-consecutive time slots on the radio carrier.

In only one of many possible embodiments of a TDMA system as described  
15 above, the TIA/EIA/IS-54-B standard provided that each TDMA frame consists of six consecutive time slots and has a duration of 40 milliseconds (msec). Thus, each radio channel can carry from three to six DTCs (e.g., three to six telephone conversations), depending on the source rates of the speech coder/decoders (codecs) used to digitally  
20 encode the conversations. Such speech codecs can operate at either full-rate or half-rate. A full-rate DTC requires twice as many time slots in a given time period as a half-rate DTC, and in TIA/EIA/IS-54-B, each full-rate DTC uses two slots of each TDMA frame, i.e., the first and fourth, second and fifth, or third and sixth of a TDMA frame's six slots. Each half-rate DTC uses one time slot of each TDMA  
25 frame. During each DTC time slot, 324 bits are transmitted, of which the major portion, 260 bits, is due to the speech output of the codec, including bits due to error correction coding of the speech output, and the remaining bits are used for guard times and overhead signalling for purposes such as synchronization.

It can be seen that the TDMA cellular system operates in a buffer-and-burst,  
30 or discontinuous-transmission, mode: each mobile station transmits (and receives) only during its assigned time slots. At full rate, for example, a mobile station might

-3-

transmit during slot 1, receive during slot 2, idle during slot 3, transmit during slot 4, receive during slot 5, and idle during slot 6, and then repeat the cycle during succeeding TDMA frames. Therefore, the mobile station, which may be battery-powered, can be switched off, or sleep, to save power during the time slots when it is  
5 neither transmitting nor receiving.

In addition to voice or traffic channels, cellular radio communication systems also provide paging/access, or control, channels for carrying call-setup messages between base stations and mobile stations. According to TIA/EIA/IS-54-B, for example, there are twenty-one dedicated analog control channels (ACCs), which have  
10 predetermined fixed frequencies for transmission and reception located near 800 MHz. Since these ACCs are always found at the same frequencies, they can be readily located and monitored by the mobile stations.

For example, when in an idle state (i.e., switched on but not making or receiving a call), a mobile station in a TIA/EIA/IS-54-B system tunes to and then  
15 regularly monitors the strongest control channel (generally, the control channel of the cell in which the mobile station is located at that moment) and may receive or initiate a call through the corresponding base station. When moving between cells while in the idle state, the mobile station will eventually "lose" radio connection on the control channel of the "old" cell and tune to the control channel of the "new" cell. The  
20 initial tuning and subsequent re-tuning to control channels are both accomplished automatically by scanning all the available control channels at their known frequencies to find the "best" control channel. When a control channel with good reception quality is found, the mobile station remains tuned to this channel until the quality deteriorates again. In this way, mobile stations stay "in touch" with the system.

25 While in the idle state, a mobile station must monitor the control channel for paging messages addressed to it. For example, when an ordinary telephone (land-line) subscriber calls a mobile subscriber, the call is directed from the public switched telephone network (PSTN) to a mobile switching center (MSC) that analyzes the dialed number. If the dialed number is validated, the MSC requests some or all of a  
30 number of radio base stations to page the called mobile station by transmitting over their respective control channels paging messages that contain the mobile identification

-4-

number (MIN) of the called mobile station. Each idle mobile station receiving a paging message compares the received MIN with its own stored MIN. The mobile station with the matching stored MIN transmits a page response over the particular control channel to the base station, which forwards the page response to the MSC.

5           Upon receiving the page response, the MSC selects an AVC or a DTC available to the base station that received the page response, switches on a corresponding radio transceiver in that base station, and causes that base station to send a message via the control channel to the called mobile station that instructs the called mobile station to tune to the selected voice or traffic channel. A through-  
10 connection for the call is established once the mobile station has tuned to the selected AVC or DTC.

The performance of the system having ACCs that is specified by TIA/EIA/IS-54-B has been improved in a system having digital control channels (DCCHs) that is specified in TIA/EIA/IS-136. Using such DCCHs, each TIA/EIA/IS-54-B radio  
15 channel can carry DTCs only, DCCHs only, or a mixture of both DTCs and DCCHs. Within the TIA/EIA/IS-136-B framework, each radio carrier frequency can have up to three full-rate DTCs/DCCHs, or six half-rate DTCs/DCCHs, or any combination in between, for example, one full-rate and four half-rate DTCs/DCCHs.

In general, however, the transmission rate of the DCCH need not coincide  
20 with the half-rate and full-rate specified in TIA/EIA/IS-54-B, and the length of the DCCH slots may not be uniform and may not coincide with the length of the DTC slots. The DCCH may be defined on an TIA/EIA/IS-54-B radio channel and may consist, for example, of every n-th slot in the stream of consecutive TDMA slots. In this case, the length of each DCCH slot may or may not be equal to 6.67 msec,  
25 which is the length of a DTC slot according to TIA/EIA/IS-54-B. Alternatively (and without limitation on other possible alternatives), these DCCH slots may be defined in other ways known to one skilled in the art.

In cellular telephone systems, an air link protocol is required in order to allow a mobile station to communicate with the base stations and MSC. The  
30 communications link protocol is used to initiate and to receive cellular telephone calls. The communications link protocol is commonly referred to within the communications

-5-

industry as a Layer 2 protocol, and its functionality includes the delimiting, or framing, of Layer 3 messages. These Layer 3 messages may be sent between communicating Layer 3 peer entities residing within mobile stations and cellular switching systems. The physical layer (Layer 1) defines the parameters of the physical communications channel, e.g., radio frequency spacing, modulation characteristics, etc. Layer 2 defines the techniques necessary for the accurate transmission of information within the constraints of the physical channel, e.g., error correction and detection, etc. Layer 3 defines the procedures for reception and processing of information transmitted over the physical channel.

Communications between mobile stations and the cellular switching system (the base stations and the MSC) can be described in general with reference to FIGS. 1 and 2. FIG. 1 schematically illustrates pluralities of Layer 3 messages 11, Layer 2 frames 13, and Layer 1 channel bursts, or time slots, 15. In FIG. 1, each group of channel bursts corresponding to each Layer 3 message may constitute a logical channel, and as described above, the channel bursts for a given Layer 3 message would usually not be consecutive slots on an TIA/EIA/136 carrier. On the other hand, the channel bursts could be consecutive; as soon as one time slot ends, the next time slot could begin.

Each Layer 1 channel burst 15 contains a complete Layer 2 frame as well as other information such as, for example, error correction information and other overhead information used for Layer 1 operation. Each Layer 2 frame contains at least a portion of a Layer 3 message as well as overhead information used for Layer 2 operation. Although not indicated in FIG. 1, each Layer 3 message would include various information elements that can be considered the payload of the message, a header portion for identifying the respective message's type, and possibly padding.

Each Layer 1 burst and each Layer 2 frame is divided into a plurality of different fields. In particular, a limited-length DATA field in each Layer 2 frame contains the Layer 3 message 11. Since Layer 3 messages have variable lengths depending upon the amount of information contained in the Layer 3 message, a plurality of Layer 2 frames may be needed for transmission of a single Layer 3 message. As a result, a plurality of Layer 1 channel bursts may also be needed to

-6-

transmit the entire Layer 3 message as there is a one-to-one correspondence between channel bursts and Layer 2 frames.

As noted above, when more than one channel burst is required to send a Layer 3 message, the several bursts are not usually consecutive bursts on the radio channel. Moreover, the several bursts are not even usually successive bursts devoted to the particular logical channel used for carrying the Layer 3 message. Since time is required to receive, process, and react to each received burst, the bursts required for transmission of a Layer 3 message are usually sent in a staggered format, as schematically illustrated in FIG. 2(a) and as described above in connection with the TIA/EIA/IS-136 standard.

FIG. 2(a) shows a general example of a forward (or downlink) DCCH configured as a succession of time slots 1, 2, . . . , N, . . . included in the consecutive time slots 1, 2, . . . sent on a carrier frequency. These DCC slots may be defined on a radio channel such as that specified by TIA/EIA/IS-136, and may consist, as seen in FIG. 2(a) for example, of every n-th slot in a series of consecutive slots. Each DCC slot has a duration that may or may not be 6.67 msec, which is the length of a DTC slot according to the TIA/EIA/IS-136 standard.

As shown in FIG. 2(a), the DCCH slots may be organized into superframes (SF), and each superframe includes a number of logical channels that carry different kinds of information. One or more DCCH slots may be allocated to each logical channel in the superframe. The exemplary downlink superframe in FIG. 2(a) includes three logical channels: a broadcast control channel (BCCH) including six successive slots for overhead messages; a paging channel (PCH) including one slot for paging messages; and an access response channel (ARCH) including one slot for channel assignment and other messages. The remaining time slots in the exemplary superframe of FIG. 2(a) may be dedicated to other logical channels, such as additional paging channels PCH or other channels. Since the number of mobile stations is usually much greater than the number of slots in the superframe, each paging slot is used for paging several mobile stations that share some unique characteristic, e.g., the last digit of the MIN.

-7-

FIG. 2(b) illustrates a preferred information format for the slots of a forward DCCH. The information transferred in each slot comprises a plurality of fields, and FIG. 2(b) indicates the number of bits in each field above that field. The bits sent in the SYNC field are used in a conventional way to help ensure accurate reception of the CSFP and DATA fields. The SYNC field carries a predetermined bit pattern used by the base stations to find the start of the slot. The SCF field is used to control a random access channel (RACH), which is used by the mobile to request access to the system. The CSFP information conveys a coded superframe phase value that enables the mobile stations to find the start of each superframe. This is just one example for the information format in the slots of the forward DCCH. FIG. 2(c) illustrates the 12 bit allocation for the CSFP field which includes bits  $d_7$ - $d_0$  and check bits  $b_3$ - $b_0$ .

For purposes of efficient sleep mode operation and fast cell selection, the BCCH may be divided into a number of sub-channels. A BCCH structure is known that allows the mobile station to read a minimum amount of information when it is switched on (when it locks onto a DCCH) before being able to access the system (place or receive a call). After being switched on, an idle mobile station needs to regularly monitor only its assigned PCH slots (usually one in each superframe); the mobile can sleep during other slots. The ratio of the mobile's time spent reading paging messages and its time spent asleep is controllable and represents a tradeoff between call-set-up delay and power consumption.

Since each TDMA time slot has a certain fixed information carrying capacity, each burst typically carries only a portion of a Layer 3 message as noted above. In the uplink direction, multiple mobile stations attempt to communicate with the system on a contention basis, while multiple mobile stations listen for Layer 3 messages sent from the system in the downlink direction. In known systems, any given Layer 3 message must be carried using as many TDMA channel bursts as required to send the entire Layer 3 message.

Digital control and traffic channels are desirable for reasons, such as supporting longer sleep periods for the mobile units, which results in longer battery life. Digital traffic channels and digital control channels have expanded functionality for optimizing system capacity and supporting hierarchical cell structures, i.e.,

-8-

structures of macrocells, microcells, picocells, etc. The term "macrocell" generally refers to a cell having a size comparable to the sizes of cells in a conventional cellular telephone system (e.g., a radius of at least about 1 kilometer), and the terms "microcell" and "picocell" generally refer to progressively smaller cells. For example, a microcell might cover a public indoor or outdoor area, e.g., a convention center or a busy street, and a picocell might cover an office corridor or a floor of a high-rise building. From a radio coverage perspective, macrocells, microcells, and picocells may be distinct from one another or may overlap one another to handle different traffic patterns or radio environments.

10           FIG. 3 is an exemplary hierarchical, or multi-layered, cellular system. An umbrella macrocell 10 represented by a hexagonal shape makes up an overlying cellular structure. Each umbrella cell may contain an underlying microcell structure. The umbrella cell 10 includes microcell 20 represented by the area enclosed within the dotted line and microcell 30 represented by the area enclosed within the dashed line corresponding to areas along city streets, and picocells 40, 50, and 60, which cover individual floors of a building. The intersection of the two city streets covered by the microcells 20 and 30 may be an area of dense traffic concentration, and thus might represent a hot spot.

20           FIG. 4 represents a block diagram of an exemplary cellular mobile radiotelephone system, including an exemplary base station 110 and mobile station 120. The base station includes a control and processing unit 130 which is connected to the MSC 140 which in turn is connected to the PSTN (not shown). General aspects of such cellular radiotelephone systems are known in the art, as described by U.S. Patent No. 5,175,867 to Wejke et al., entitled "Neighbor-Assisted Handoff in a Cellular Communication System," which is incorporated in this application by reference.

30           The base station 110 handles a plurality of voice channels through a voice channel transceiver 150, which is controlled by the control and processing unit 130. Also, each base station includes a control channel transceiver 160, which may be capable of handling more than one control channel. The control channel transceiver 160 is controlled by the control and processing unit 130. The control channel

-10-

data communication may be well suited to constant-bandwidth applications, it is relatively inefficient for low-bandwidth and "bursty" applications.

Packet-switched technology, which may be connection-oriented (e.g., X.25) or "connectionless" (e.g., the Internet Protocol, "IP"), does not require the set-up and tear-down of a physical connection, which is in marked contrast to circuit-switched technology. This reduces the data latency and increases the efficiency of a channel in handling relatively short, bursty, or interactive transactions. A connectionless packet-switched network distributes the routing functions to multiple routing sites, thereby avoiding possible traffic bottlenecks that could occur when using a central switching hub. Data is "packetized" with the appropriate end-system addressing and then transmitted in independent units along the data path. Intermediate systems, sometimes called "routers", stationed between the communicating end-systems make decisions about the most appropriate route to take on a per packet basis. Routing decisions are based on a number of characteristics, including: least-cost route or cost metric; capacity of the link; number of packets waiting for transmission; security requirements for the link; and intermediate system (node) operational status.

Packet transmission along a route that takes into consideration path metrics, as opposed to a single circuit set up, offers application and communications flexibility. It is also how most standard local area networks (LANs) and wide area networks (WANs) have evolved in the corporate environment. Packet switching is appropriate for data communications because many of the applications and devices used, such as keyboard terminals, are interactive and transmit data in bursts. Instead of a channel being idle while a user inputs more data into the terminal or pauses to think about a problem, packet switching interleaves multiple transmissions from several terminals onto the channel.

Packet data provides more network robustness due to path independence and the routers' ability to select alternative paths in the event of network node failure. Packet switching, therefore, allows for more efficient use of the network lines. Packet technology offers the option of billing the end user based on amount of data transmitted instead of connection time. If the end user's application has been designed to make efficient use of the air link, then the number of packets transmitted

-9-

transceiver 160 broadcasts control information over the control channel of the base station or cell to mobiles locked to that control channel. It will be understood that the transceivers 150 and 160 can be implemented as a single device, like the voice and control transceiver 170, for use with DCCHs and DTCs that share the same radio carrier frequency.

The mobile station 120 receives the information broadcast on a control channel at its voice and control channel transceiver 170. Then, the processing unit 180 evaluates the received control channel information, which includes the characteristics of cells that are candidates for the mobile station to lock on to, and determines on which cell the mobile should lock. Advantageously, the received control channel information not only includes absolute information concerning the cell with which it is associated, but also contains relative information concerning other cells proximate to the cell with which the control channel is associated, as described in U.S. Patent No. 5,353,332 to Raith et al., entitled "Method and Apparatus for Communication Control in a Radiotelephone System," which is incorporated in this application by reference.

To increase the user's "talk time", i.e., the battery life of the mobile station, a digital forward control channel (base station to mobile station) may be provided that can carry the types of messages specified for current analog forward control channels (FOCCs), but in a format which allows an idle mobile station to read overhead messages when locking onto the FOCC and thereafter only when the information has changed; the mobile sleeps at all other times. In such a system, some types of messages are broadcast by the base stations more frequently than other types, and mobile stations need not read every message broadcast.

The systems specified by the TIA/EIA/IS-54-B and TIA/EIA/IS-136 standards are circuit-switched technology, which is a type of "connection-oriented" communication that establishes a physical call connection and maintains that connection for as long as the communicating end-systems have data to exchange. The direct connection of a circuit switch serves as an open pipeline, permitting the end-systems to use the circuit for whatever they deem appropriate. While circuit-switched

-11-

will be minimal. If each individual user's traffic is held to a minimum, then the service provider has effectively increased network capacity.

Packet networks are usually designed and based on industry-wide data standards such as the open system interface (OSI) model or the TCP/IP protocol stack. These standards have been developed, whether formally or de facto, for many years, and the applications that use these protocols are readily available. The main objective of standards-based networks is to achieve interconnectivity with other networks. The Internet is today's most obvious example of such a standards-based network pursuit of this goal.

Packet networks, like the Internet or a corporate LAN, are integral parts of today's business and communications environments. As mobile computing becomes pervasive in these environments, wireless service providers such as those using TIA/EIA/IS-136 are best positioned to provide access to these networks. Nevertheless, the data services provided by or proposed for cellular systems are generally based on the circuit-switched mode of operation, using a dedicated radio channel for each active mobile user.

A few exceptions to data services for cellular systems based on the circuit-switched mode of operation are described in the following documents, which include the packet data concepts.

U.S. Patent No. 4,887,265 and "Packet Switching in Digital Cellular Systems", Proc. 38th IEEE Vehicular Technology Conf., pp. 414-418 (June 1988) describe a cellular system providing shared packet data radio channels, each one capable of accommodating multiple data calls. A mobile station requesting packet data service is assigned to a particular packet data channel using essentially regular cellular signalling. The system may include packet access points (PAPS) for interfacing with packet data networks. Each packet data radio channel is connected to one particular PAP and is thus capable of multiplexing data calls associated with that PAP. Handovers are initiated by the system in a manner that is largely similar to the handover used in the same system for voice calls. A new type of handover is added for those situations when the capacity of a packet channel is insufficient.

-12-

These documents are data-call oriented and based on using system-initiated handover in a similar way as for regular voice calls. Applying these principles for providing general purpose packet data services in a TDMA cellular system would result in spectrum-efficiency and performance disadvantages.

5 U.S. Patent No. 4,916,691 describes a new packet mode cellular radio system architecture and a new procedure for routing (voice and/or data) packets to a mobile station. Base stations, public switches via trunk interface units, and a cellular control unit are linked together via a WAN. The routing procedure is based on mobile-station-initiated handovers and on adding to the header of any packet transmitted from  
10 a mobile station (during a call) an identifier of the base station through which the packet passes. In case of an extended period of time between subsequent user information packets from a mobile station, the mobile station may transmit extra control packets for the purpose of conveying cell location information.

The cellular control unit is primarily involved at call establishment, when it  
15 assigns to the call a call control number. It then notifies the mobile station of the call control number and the trunk interface unit of the call control number and the identifier of the initial base station. During a call, packets are then routed directly between the trunk interface unit and the currently serving base station.

The system described in U.S. Patent No. 4,916,691 is not directly related to  
20 the specific problems of providing packet data services in TDMA cellular systems.

"Packet Radio in GSM", European Telecommunications Standards Institute (ETSI) T Doc SMG 4 58/93 (Feb. 12, 1993) and "A General Packet Radio Service Proposed for GSM" presented during a seminar entitled "GSM in a Future  
25 Competitive Environment", Helsinki, Finland (Oct. 13, 1993) outline a possible packet access protocol for voice and data in GSM. These documents directly relate to TDMA cellular systems, i.e., GSM, and although they outline a possible organization of an optimized shared packet data channel, they do not deal with the aspects of integrating packet data channels in a total system solution.

"Packet Data over GSM Network", T Doc SMG 1 238/93, ETSI (Sept. 28,  
30 1993) describes a concept of providing packet data services in GSM based on first using regular GSM signalling and authentication to establish a virtual channel between

-13-

a packet mobile station and an "agent" handling access to packet data services. With regular signalling modified for fast channel setup and release, regular traffic channels are then used for packet transfer. This document directly relates to TDMA cellular systems, but since the concept is based on using a "fast switching" version of existing  
5 GSM traffic channels, it has disadvantages in terms of spectrum efficiency and packet transfer delays (especially for short messages) compared to a concept based on optimized shared packet data channels.

Cellular Digital Packet Data (CDPD) System Specification, Release 1.0 (July 1993), describes a concept for providing packet data services that utilizes available  
10 radio channels on current Advanced Mobile Phone Service (AMPS) systems, i.e., the North American analog cellular system. CDPD is a comprehensive, open specification endorsed by a group of U.S. cellular operators. Items covered include external interfaces, air link interfaces, services, network architecture, network management, and administration.

15 The specified CDPD system is to a large extent based on an infrastructure that is independent of the existing AMPS infrastructure. Commonalities with AMPS systems are limited to utilization of the same type of radio frequency channels and the same base station sites (the base station used by CDPD may be new and CDPD specific) and employment of a signalling interface for coordinating channel  
20 assignments between the two systems.

Routing a packet to a mobile station is based on, first, routing the packet to a home network node (home Mobile Data Intermediate System, MD-IS) equipped with a home location register (HLR) based on the mobile station address; then, when  
25 necessary, routing the packet to a visited, serving MD-IS based on HLR information; and finally transferring the packet from the serving MD-IS via the current base station, based on the mobile station reporting its cell location to its serving MD-IS.

Although the CDPD System Specification is not directly related to the specific problems of providing packet data services in TDMA cellular systems that are addressed by this application, the network aspects and concepts described in the  
30 CDPD System Specification can be used as a basis for the network aspects needed for

-14-

an air link protocol in accordance with this invention. The CDPD System Specification is incorporated in this application by reference.

The CDPD network is designed to be an extension of existing data communications networks and the AMPS cellular network. Existing connectionless  
5 network protocols may be used to access the CDPD network. Since the network is always considered to be evolving, it uses an open network design that allows the addition of new network layer protocols when appropriate. The CDPD network services and protocols are limited to the Network Layer of the OSI model and below. Doing so allows upper-layer protocols and applications development without changing  
10 the underlying CDPD network.

From the mobile subscriber's perspective, the CDPD network is a wireless mobile extension of traditional networks, both data and voice. By using a CDPD service provider network's service, the subscriber is able seamlessly to access data applications, many of which may reside on traditional data networks. The CDPD  
15 system may be viewed as two interrelated service sets: CDPD network support services and CDPD network services.

CDPD network support services perform duties necessary to maintain and administer the CDPD network. These services are: accounting server; network management system; message transfer server; and authentication server. These  
20 services are defined to permit interoperability among service providers. As the CDPD network evolves technically beyond its original AMPS infrastructure, it is anticipated that the support services shall remain unchanged. The functions of network support services are necessary for any mobile network and are independent of radio frequency (RF) technology.

CDPD network services are data transfer services that allow subscribers to  
25 communicate with data applications. Additionally, one or both ends of the data communications may be mobile.

To summarize, there is a need for a system providing general purpose packet data services in D-AMPS cellular systems, based on providing shared packet-data  
30 channels optimized for packet data. This application is directed to systems and methods that provide the combined advantages of a connection-oriented network like

-15-

that specified by the TIA/EIA/IS-136 standard and a connectionless, packet data network. Furthermore, the invention is directed to enhancing timing, decoding and encoding aspects of electrical communication in wireless communication systems.

5

### SUMMARY

In accordance with one aspect of the invention, there is provided a method for encoding superframe phase (SFP) and packet channel feedback (PCF) information into a coded superframe phase/packet channel feedback (CSFP/PCF) field that is sent on a forward packet data channel (PDCH). More particularly, for distinguishing among a digital control channel (DCCH), a digital traffic channel (DTC) and a PDCH, a logic operation is performed on the logical value of the SFP information of the PDCH before transmittal. As a result of this operation, transmitted SFP values of a PDCH will generally decrease by a predetermined decrement value, while the transmitted SFP values of a DCCH will generally increase by a predetermined increment value.

15

### BRIEF DESCRIPTION OF THE DRAWINGS

The features and advantages of Applicants' invention will be understood by reading this description in conjunction with the drawings in which:

FIG. 1 schematically illustrates pluralities of Layer 3 messages, Layer 2 frames, and Layer 1 channel bursts, or time slots;

20

FIG. 2(a) shows a forward DCCH configured as a succession of time slots included in the consecutive time slots sent on a carrier frequency;

FIG. 2(b) shows an example of an IS-136 DCCH field slot format;

FIG. 2(c) shows an example of a CSFP bit allocation;

25

FIG. 3 illustrates an exemplary hierarchical, or multi-layered, cellular system;

FIG. 4 is a block diagram of an exemplary cellular mobile radiotelephone system, including an exemplary base station and mobile station;

FIG. 5 illustrates one example of a possible message mapping sequence across layers;

30

FIG. 6 illustrates an example of a slot format for BMI → MS messaging on PDCH; and

-16-

FIG. 7 illustrates an example of a CSFP/PCF field having eight information bits.

#### DETAILED DESCRIPTION

5 To aid in understanding, a possible sequence for mapping higher-layer messages into lower-layer messages is illustrated in FIG. 5. Specifically, FIG. 5 shows, using a dedicated PDCH as an example, how a Layer 3 message (which may be derived from higher layers, such as a frame according to the CDPD mobile data link protocol) is mapped into several Layer 2 frames, an example of a Layer 2 frame  
10 mapping onto a time slot, and an example of time slot mapping onto a PDCH channel. (See also FIGs. 2(a), 2(b), 2(c)). The length of the forward packet data channel FPDCH time slots and reverse packet data channel RPDCH bursts is fixed, although there may be three forms of RPDCH bursts which have different fixed lengths. The FPDCH slot and the full-rate PDCH are assumed to be on the physical  
15 layer in FIG. 5. For purposes of explanation, the TDMA frame structure is assumed to be the same as the IS-136 DCCH and DTC; the TIA/EIA/IS-136 standard is incorporated in this application by reference. To maximize throughput when a multi-rate channel is used (e.g., double-rate PDCH or triple-rate PDCH), a different FPDCH slot format is specified as shown in FIG. 5.

20 FIG. 6 depicts a slot format which can be used for forward messaging (i.e., from the base station mobile switching center interworking (BMI) to the mobile station (MS)) on a PDCH channel as shown in FIG. 5. It will be appreciated that the slot format illustrated in FIG. 6 differs from the IS-136 DCCH BMI → MS slot format in that packet channel feedback (PCF) fields replace the shared channel  
25 feedback (SCF) fields. Another difference is that a CSFP/PCF field replaces the CSFP field in the IS-136 DCCH format. The CSFP/PCF field conveys information regarding the superframe phase SFP, so that mobile stations can determine the start of a superframe.

The PCF field controls access on the RPDCH and includes busy/reserved/idle  
30 (BRI), received/not received (R/N), partial echo (PE) and partial echo qualifier (PEQ) information. The BRI, CPE, and R/N data are as specified in IS-136. The additional

-17-

PEQ information can be used for controlling the association of the PE to the BRI or R/N or both the BRI and the R/N.

In IS-136, the CSFP field can be used to discriminate between a DCCH and a DTC by taking advantage of the fact that the CSFP field of a DCCH and the coded data verification color code (CDVCC) of a DTC have no common codewords. Discrimination between a DTC and a DCCH in an IS-136 system is performed by inverting the check bits  $b_3$ - $b_0$  of the CSFP field of a received signal. Because bit errors can cause received codewords to appear as valid codewords from a different channel coding set (e.g., DTC codewords can appear as DCCH codewords, and vice versa), an additional test can be performed to discriminate between the channels. The mobile station can perform a counting up test to determine whether or not the control values are an up counter, i.e., whether the control values in codeword in successive slots trend generally upward in increment values of 1, from 0, 1, 2, ..., 31 (see FIG. 5). If the SFP values display a generally upward trend (because of bits errors, for example, the trend may not be a perfect up counter), the mobile station determines that the received signal is a DCCH; if the control values do not display a generally upward trend (i.e., is generally constant), the received signal is determined to be a DTC.

For the packet data system in accordance with the present invention, SFP and PCF information are encoded into the CSFP/PCF field using the same basic channel coding method ((12, 8) coding) used in IS-136. The CSFP/PCF field can be used to distinguish between a PDCH, a DCCH, and a DTC.

The CSFP/PCF field is expanded from the CSFP field of IS-136, and can be analyzed according to a new technique which enables the mobile station to distinguish among a DCCH, a DTC, and a PDCH. In order to distinguish the additional channel, an exclusive OR or other logic operation can be performed on the logical value of the SFP (e.g., with 1,1,1,1,1) and the result is encoded and transmitted on the PDCH in the CSFP/PCF field. Advantageously, the same (12,8) channel coding as in IS-136 is used for the CSFP/PCF field. It will be understood that coding and decoding of this information can employ other techniques and enhancements, such as those described in Applicant's U.S. Patent Application No. 08/544,840, filed on

-18-

October 18, 1995, for "Simplifying Decoding of Codewords in a Wireless Communication System," which is incorporated in this application by reference.

As a result of the logic operation transmitted control (SFP) values of a PDCH exhibit a generally downward trend, decrementing generally by a predetermined  
5 decrement value. As explained previously, bit errors may cause the actual decrement values of the decoded control values to vary slightly from the predetermined decrement value. Accordingly, upon receiving the PDCH bursts, a suitable discriminator in the mobile station examines the logical value of the SFP to determine if it is an up counter or a down counter. Besides the channel encoding of the SFP,  
10 which has the exclusive OR function performed thereon, the channel encoding of PEQ into CSFP/PCF and the transmittal order of the CSFP/PCF are identical to how the SFP is encoded into CSFP in IS-136. As a result, the check bits of the CSFP/PCF are inverted. In an advantageous embodiment, the most significant bit of the CSFP/PCF field, bit  $d_7$ , for example, may be reserved and set to zero, and the PEQ  
15 information may be assigned the next two MSB bits, bits  $d_6$  and  $d_5$ , for example. This is illustrated in FIG. 7.

In discriminating among DCCH, DTC, and PDCH, the following conditions will be noted. When a mobile station searches for a PDCH and examines the CSFP/PCF field of a received signal, the SFP bits of a DCCH will not exhibit an  
20 expected trend and the CDVCC field on a DTC will not produce a valid (12, 8) codeword (assuming no bit errors) because the check bits are not inverted when decoding CDVCC. When a mobile station searches for a DCCH and examines the CSFP field, SFP bits of a PDCH will not exhibit the expected trend, and the CDVCC field on a DTC will not produce a valid (12, 8) code word (assuming no bit errors).  
25 When a mobile station searches for a DTC by attempting to examine the CDVCC field, reading the CSFP/PCF field on a PDCH will not produce a valid (12, 8) codeword (assuming no bit errors) and the CSFP field on a DCCH will not produce a valid (12, 8) codeword (assuming no bit errors). Accordingly, in order to keep using (12, 8) codewords (or whatever type of channel coding is appropriate) and to be able  
30 to distinguish among PDCH, DCCH and DTC, the SFP data is inverted such that the SFP values of a PDCH demonstrate a specific (e.g., generally downward) trend.

(Because the check bits have been inverted once to distinguish between the DCCH and DTC channels, the check bits cannot be inverted again since doing so would revert to providing the original data).

To summarize, according to the present invention, three or more signal types (e.g., DTC, DCCH, or PDCH) can be distinguished by performing a logic operation on control information associated with one type such that the control information exhibits a desired trend (i.e., increases or decreases by some increment or decrement value associated with the signal type.) To discriminate between the signal types, the control information is decoded and examined (e.g., by a suitable decoder/discriminator). A first decision can be made based on the coding of the control information (e.g., determining the coding of the control information by testing each channel using an assumed decoding method until a suitable match is determined, or by testing each channel using an assumed decoding method and then selecting the channel type based on the best result), and further decisions can be made based on general trends of the decoded control information. If, using the channel decoding method associated with the first type of channel, multiple readings of the control information indicate no discernable trend, it can be determined that the signal is a first type (e.g., a DTC channel). If multiple readings of the control information using the channel decoding associated with the second type of channel exhibit a first trend (e.g., generally increasing), the signal can be categorized as a second type (e.g., a DCCH). If multiple readings of the control information using the channel decoding method associated with the third type of channel exhibit a second trend (e.g., generally decreasing) the signal can be categorized as a third type (e.g., a PDCH).

The invention being thus described, it will be obvious that the same may be varied in many ways. Such variations are not to be regarded as a departure from the spirit and scope of the invention, and all such modifications as would be obvious to one skilled in the art are intended to be included within the scope of the following claims.

-20-

**What Is Claimed Is:**

1. A method for distinguishing between three or more channel types in a wireless communication system, comprising the steps of:
  - decoding control values associated with a received signal;
  - 5 determining whether the decoded control values exhibit one of a plurality of general trends, each general trend being associated with a channel type; and
  - identifying the received signal as being one of the three or more channel types based on the general trend of the decoded control values.
- 10 2. The method of claim 1, wherein the three or more channel types include a digital traffic channel, a digital control channel, and a packet data channel.
3. The method of claim 1, wherein the general trend associated with a digital traffic channel is a generally constant trend, the general trend associated with a digital control channel is a generally increasing trend, and the general trend associated with a packet data channel is a generally decreasing trend.
- 15 4. The method of claim 1, wherein the control values associated with the received signal are derived from performing a logic operation on control values associated with a transmitted signal.
- 20 5. The method of claim 4, wherein the logic operation is an exclusive OR operation of the control values and a predetermined value.
- 25 6. The method of claim 5, wherein the predetermined value is 1,1,1,1,1.
7. The method of claim 6, wherein the exclusive OR operation is performed on control values associated with a packet data channel.
- 30 8. The method of claim 1, wherein the control values are superframe phase values contained in coded superframe phase/packet channel feedback (CSFP/PCF) fields.

-21-

9. The method of claim 1, wherein the plurality of general trends includes: generally constant, generally increasing by a predetermined increment value, and generally decreasing by a predetermined decrement value, and wherein each channel type is associated with a general trend and a predetermined increment or decrement value.

10. A device for distinguishing between two or more channel types in a wireless communication system, comprising:  
a decoder for decoding control values associated with a received signal; and  
a discriminator for determining whether the decoded control values exhibit one of a plurality of general trends, each general trend being associated with a channel type, and identifying the received signal as being one of the three or more channel types based on the general trend of the decoded control values.

11. The device of claim 10, wherein the two or more channel types include a digital traffic channel, a digital control channel, and a packet data channel.

12. The device of claim 10, wherein the general trend associated with a digital traffic channel is a generally constant trend, the general trend associated with a digital control channel is a generally increasing trend, and the general trend associated with a packet data channel is a generally decreasing trend.

13. The device of claim 10, wherein the control values associated with the received signal are derived from performing a logic operation on control values associated with a transmitted signal.

14. The device of claim 13, wherein the logic operation is an exclusive OR operation of the control values and a predetermined value.

15. The device of claim 14, wherein the predetermined value is 1,1,1,1,1.

-22-

16. The device of claim 15, wherein the exclusive OR operation is performed on control values associated with a packet data channel.

17. The device of claim 10, wherein the control values are superframe phase values contained in coded superframe phase/packet channel feedback (CSFP/PCF) fields.

18. The device of claim 10, wherein the plurality of general trends includes: generally constant, generally increasing by a predetermined increment value, and generally decreasing by a predetermined decrement value, and wherein each channel type is associated with a general trend and a predetermined increment or decrement value.

19. A method for identifying a received signal as being one of N channel types in a communication system, each channel type being encoded with one of up to N channel coding sets, comprising the steps of:

distinguishing between a first channel type and the remaining channel types based on the channel coding set of the received signal; and

identifying the received signal as being one of the remaining channel types based on whether decoded control values included in the received signals exhibit one of a plurality of general trends.

20. The method of claim 19, wherein the step of distinguishing is performed by analyzing up to M instances of the received signal until a suitable coding set match is determined.

21. The method of claim 19, wherein the plurality of general trends include generally constant, generally decreasing by one of a plurality of predetermined decrement values, or generally increasing by one of a plurality of predetermined increment values.

-23-

22. The method of claim 21, wherein the step of distinguishing is performed by decoding the received signal using each of the up to N channel coding sets until a suitable match is determined.

5           23. The method of claim 21, wherein the step of distinguishing is performed by decoding the received signal using each of the up to N channel coding sets, and selecting the best result.

10           24. The method of claim 21, wherein the N channel types include a digital traffic channel, a digital control channel, and a packet data channel.

15           25. The method of claim 24, wherein the general trend associated with a digital traffic channel is a generally constant trend, the general trend associated with a digital control channel is a generally increasing trend with an increment value of one, and the general trend associated with a packet data channel is a generally decreasing trend with a decrement value of one.

20           26. The method of claim 25, wherein the control values associated with the packet data channel are derived from performing a logic operation on control values associated with the transmitted signal.

            27. The method of claim 26, wherein the logic operation is an exclusive OR operation of the control values and a predetermined value.

25           28. The method of claim 27, wherein the predetermined value is 1,1,1,1,1.

            29. The method of claim 21, wherein the control values are superframe phase values contained in coded superframe phase/packet channel feedback (CSFP/PCF) fields.

30

-24-

30. A method for identifying a received signal as being one of up to N channel types in a communication system, each channel type having one of up to N associated channel coding sets and control information included in the received signal having one of up to N associated trends, comprising the steps of:

- 5                   making an initial determination of channel type based on the channel coding set associated with the control information;
- decoding the control information using the determined channel coding set; and
- refining the initial determination, if necessary, based on whether the
- 10   decoded control information displays one of the up to N associated trends.

31. The method of claim 30, wherein the up to N associated trends include generally constant, generally increasing by one of a plurality of increment values, or generally decreasing by one of a plurality of decrement values.

15

32. The method of claim 30, wherein the step of distinguishing is performed by decoding the received signal using each of the up to N channel coding sets until a suitable match is determined.

- 20                   33. The method of claim 30, wherein the step of distinguishing is performed by decoding the received signal using each of the up to N channel coding sets, and selecting the best result.

34. The method of claim 31, wherein the N channel types include a digital

25   traffic channel, a digital control channel, and a packet data channel.

35. The method of claim 34, wherein the general trend associated with a digital traffic channel is a generally constant trend, the general trend associated with a digital control channel is a generally increasing trend with an increment value of one,

30   and the general trend associated with a packet data channel is a generally decreasing trend with a decrement value of one.

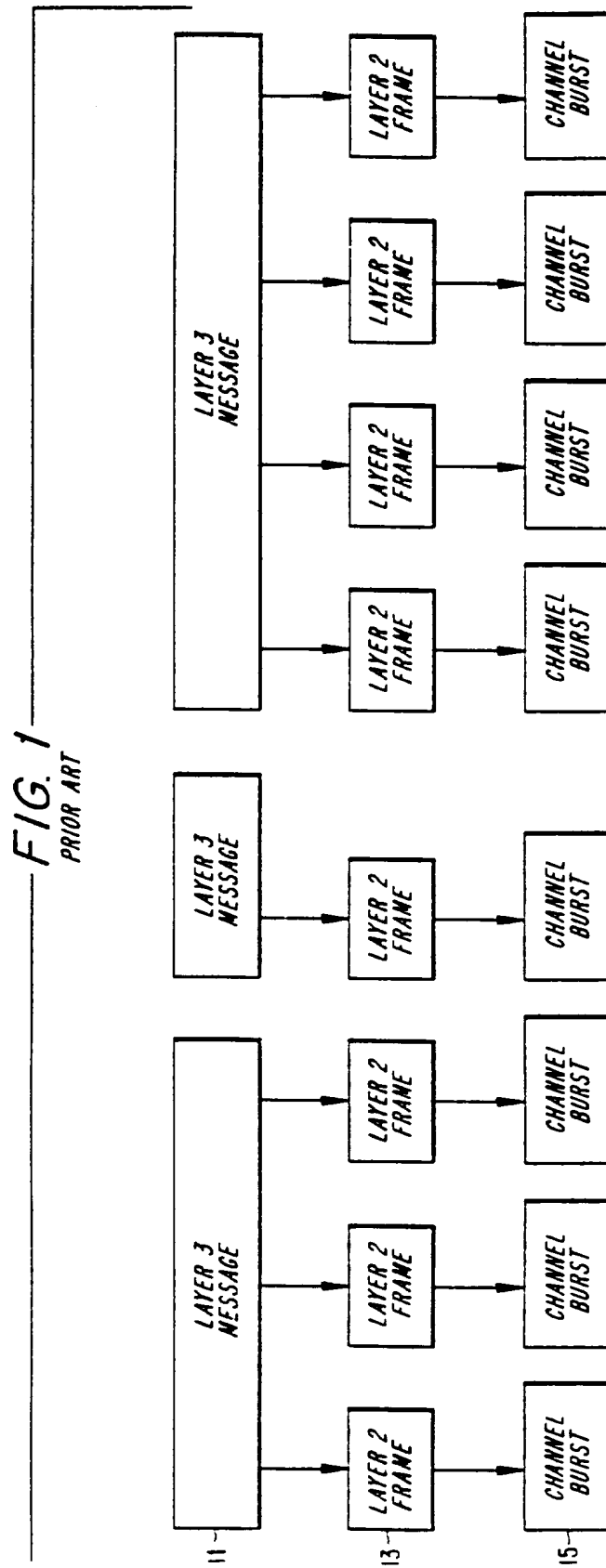
-25-

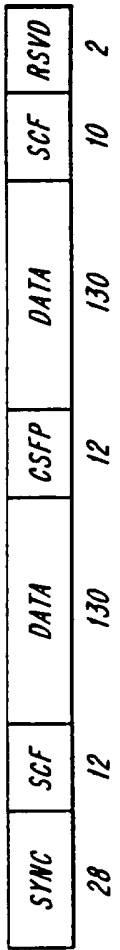
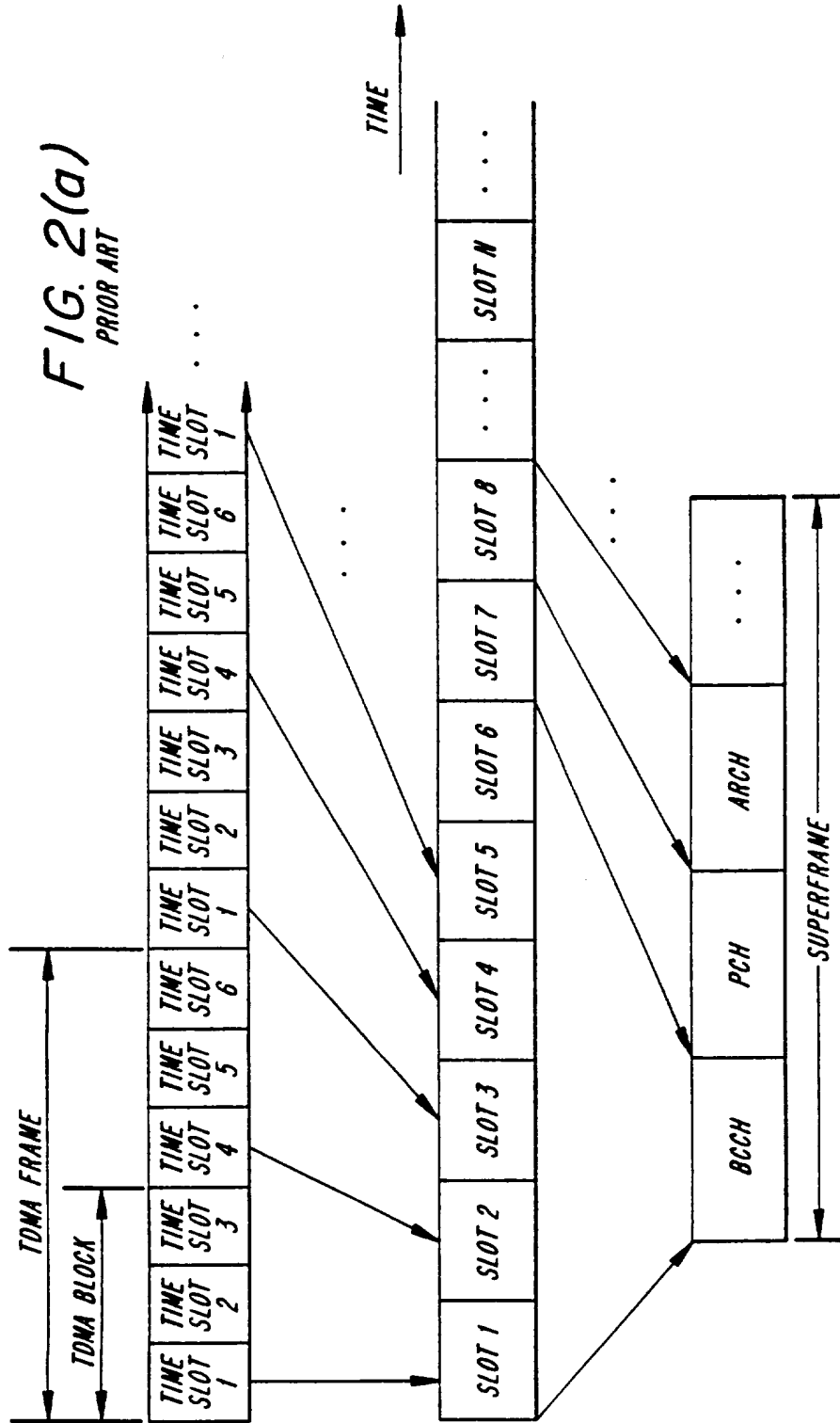
36. The method of claim 34, wherein the control values associated with the packet data channel are derived from performing a logic operation on control values associated with the transmitted signal.

5           37. The method of claim 36, wherein the logic operation is an exclusive OR operation of the control values and a predetermined value.

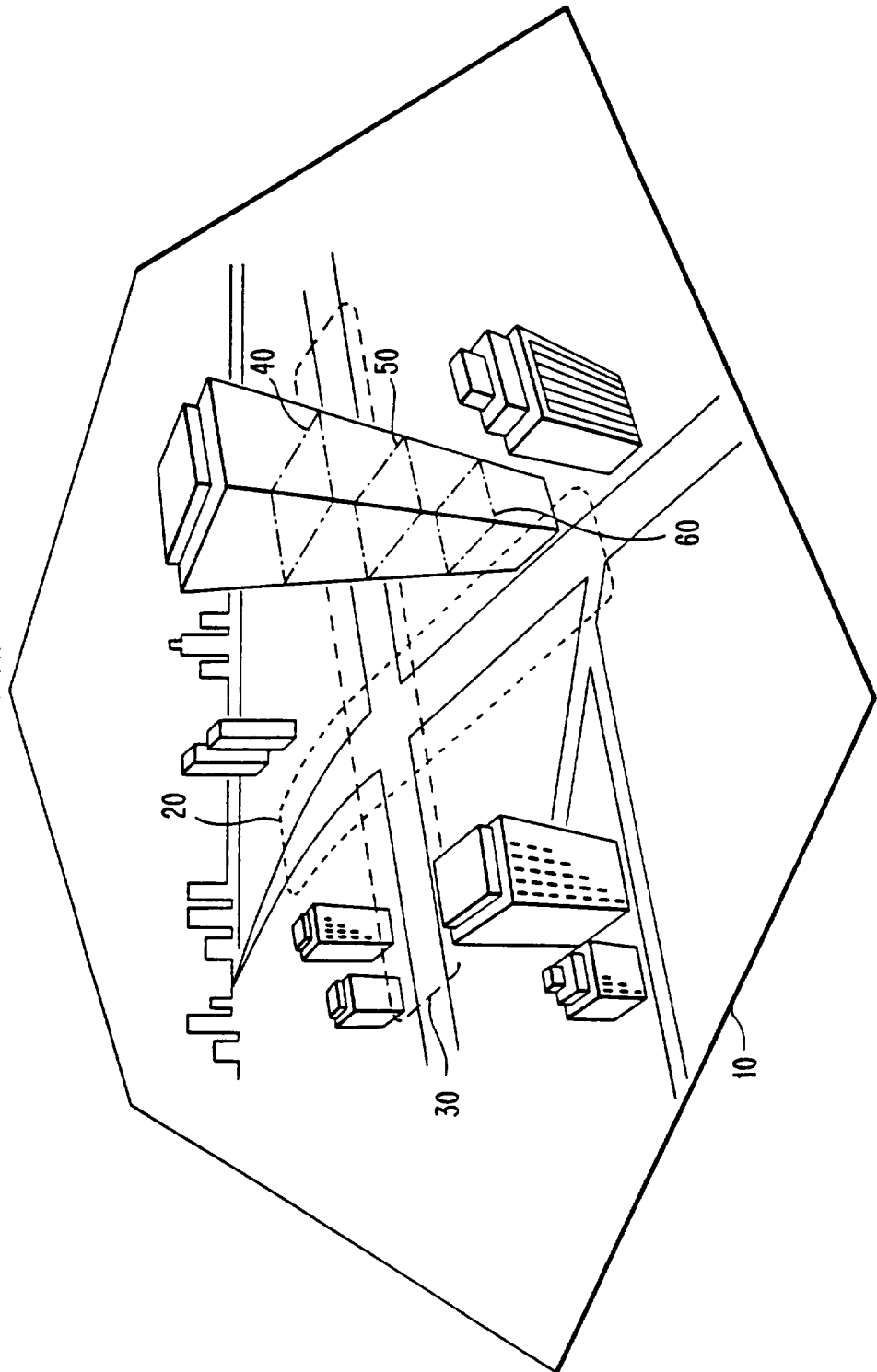
38. The method of claim 37, wherein the predetermined value is 1,1,1,1,1.

10           39. The method of claim 30, wherein the control values are superframe phase values contained in coded superframe phase/packet channel feedback (CSFP/PCF) fields.

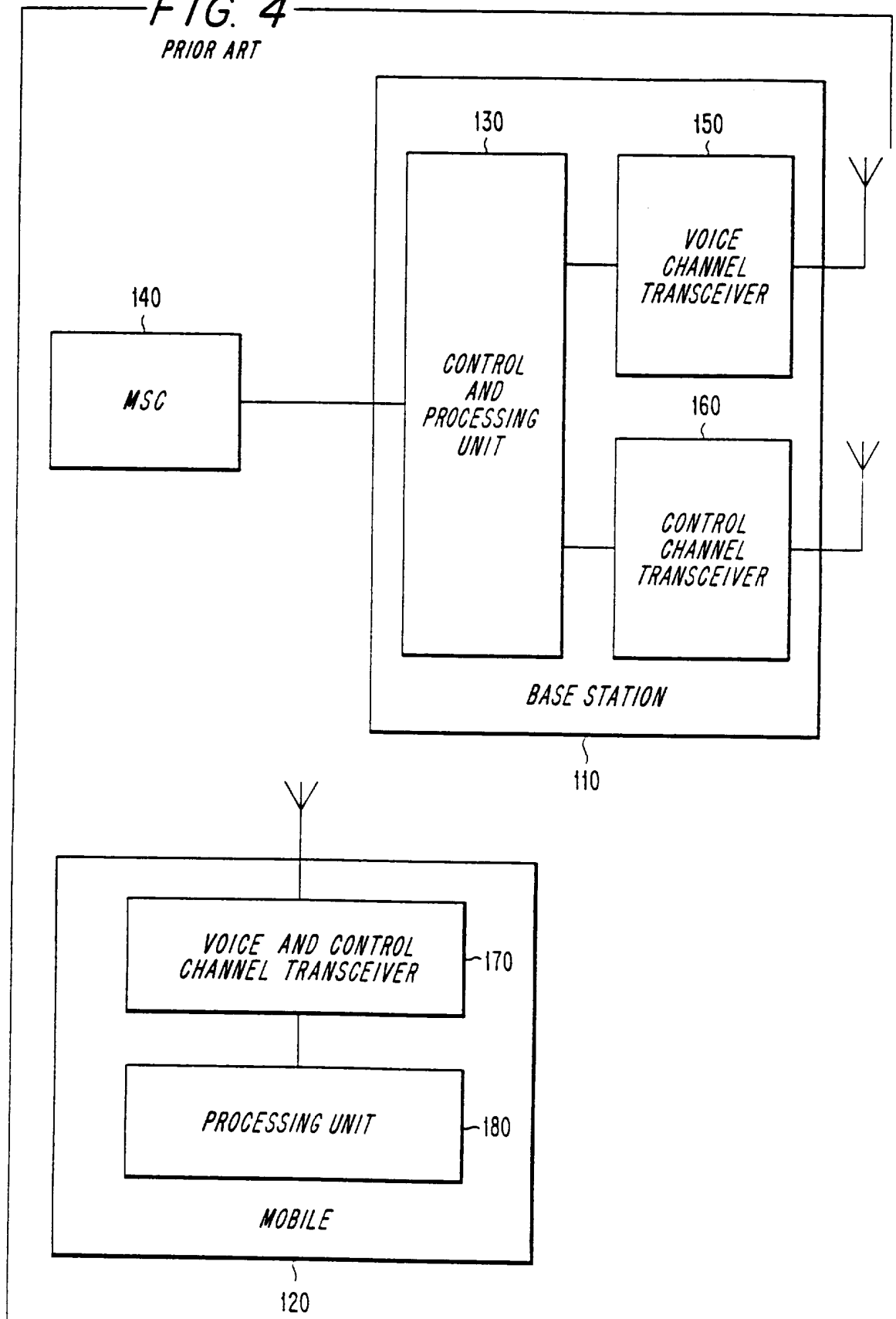




**FIG. 3**  
*PRIOR ART*



**FIG. 4**  
PRIOR ART



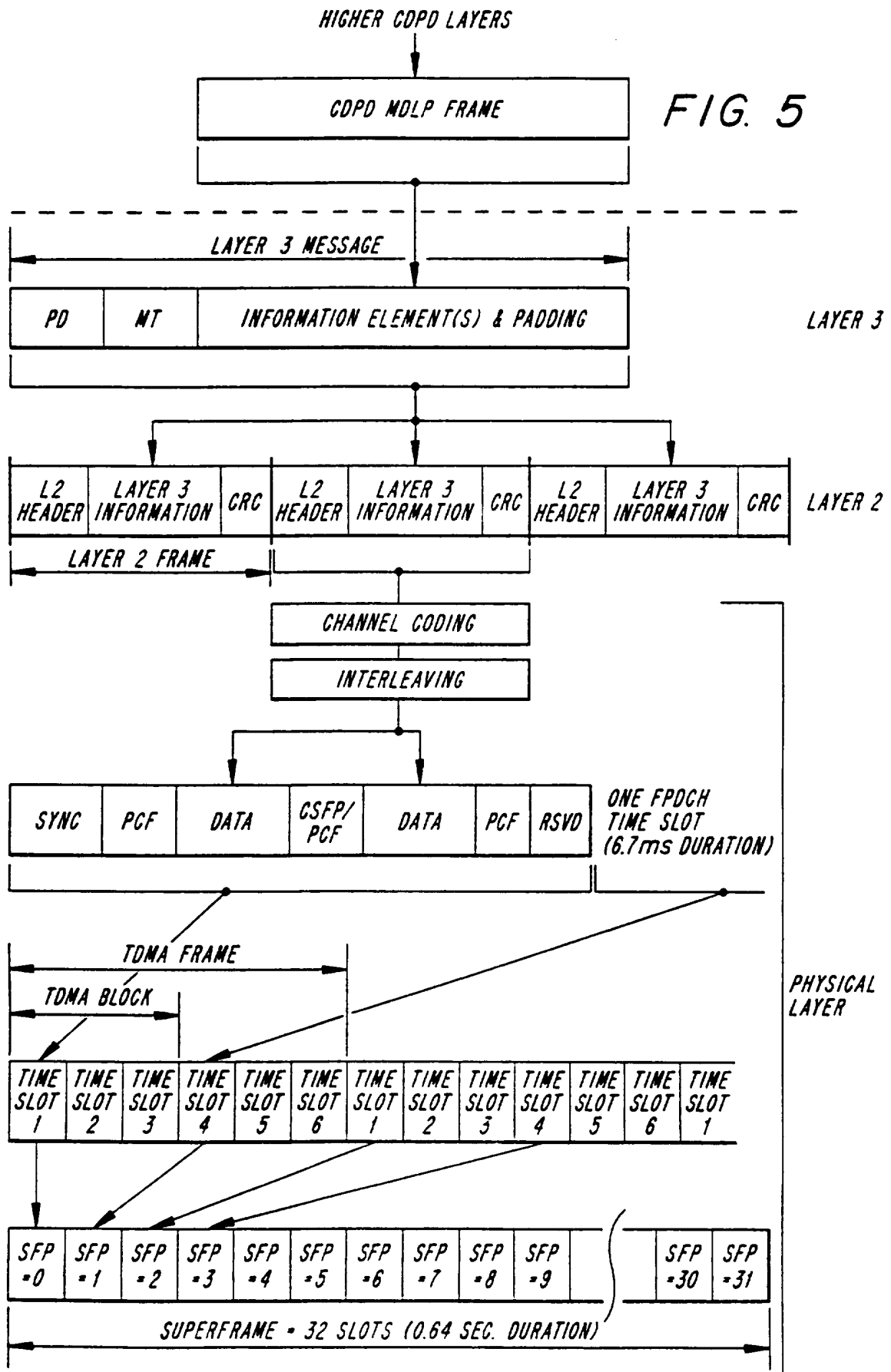


FIG. 2(c)

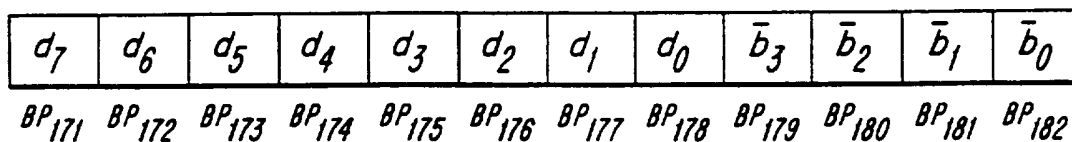


FIG. 6

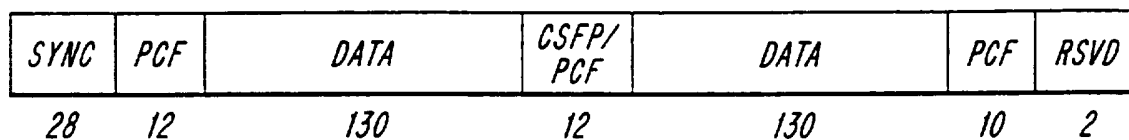


FIG. 7

