

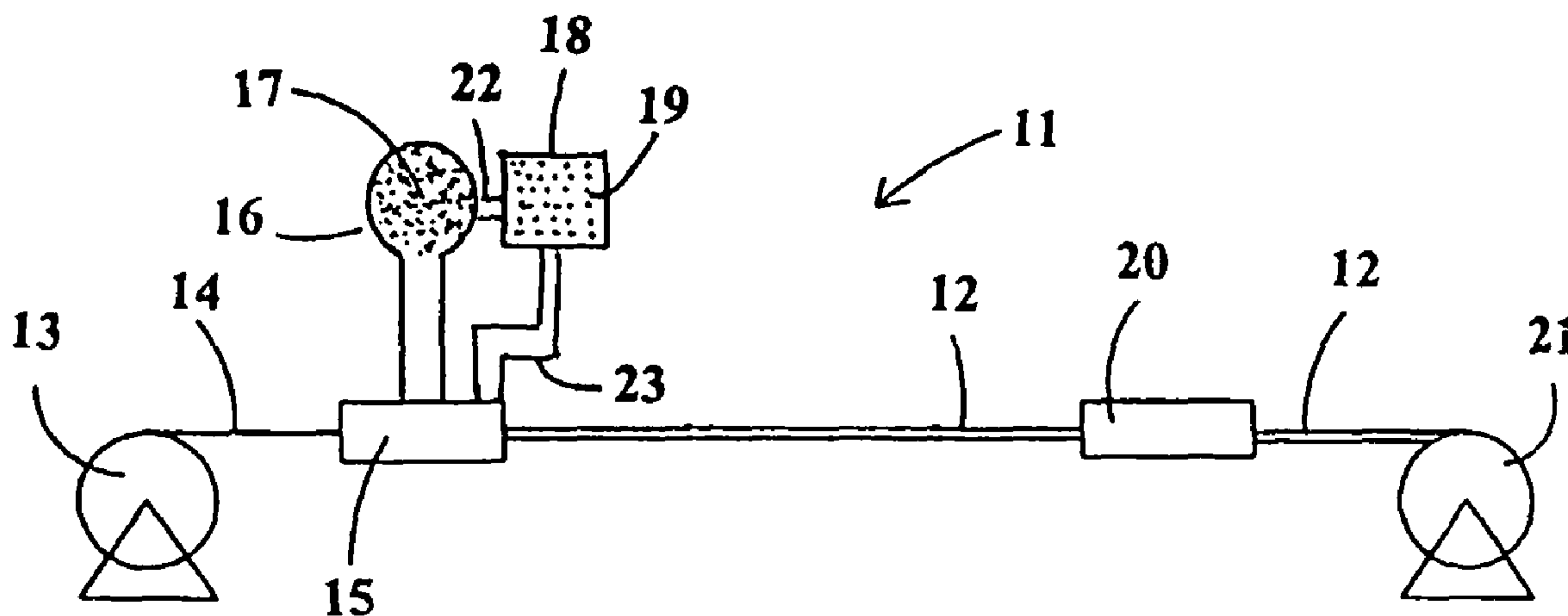

(86) Date de dépôt PCT/PCT Filing Date: 2005/02/18
 (87) Date publication PCT/PCT Publication Date: 2006/02/16
 (45) Date de délivrance/Issue Date: 2013/11/26
 (85) Entrée phase nationale/National Entry: 2008/01/09
 (86) N° demande PCT/PCT Application No.: US 2005/005165
 (87) N° publication PCT/PCT Publication No.: 2006/016895
 (30) Priorités/Priorities: 2004/07/13 (US60/587,584);
 2004/09/28 (US10/952,294)

(51) Cl.Int./Int.Cl. *B29C 41/30* (2006.01),
G02B 6/44 (2006.01), *H01B 13/14* (2006.01),
H01B 13/24 (2006.01), *H01B 7/18* (2006.01),
H01B 7/40 (2006.01)
 (72) Inventeurs/Inventors:
 KUMMER, RANDY D., US;
 REECE, DAVID, US;
 DIXON, MARK D., US;
 CARLSON, JOHN R., US;
 LAM, HAI, US;
 SASSE, PHILIP, US
 (73) Propriétaire/Owner:
 SOUTHWIRE COMPANY, US
 (74) Agent: KIRBY EADES GALE BAKER

(54) Titre : CABLE ELECTRIQUE POSSEDANT UNE SURFACE AVEC UN COEFFICIENT DE FROTTEMENT REDUIT
 (54) Title: ELECTRICAL CABLE HAVING A SURFACE WITH REDUCED COEFFICIENT OF FRICTION



(57) Abrégé/Abstract:

The mixture of plastic (17) and lubricating material (19) being coated on the electrical conductive wire or fiber optic wire by extruding head (15) to form an electrical cable or optical cable (12) having a surface with reduced coefficient of friction.



(12) INTERNATIONAL APPLICATION PUBLISHED UNDER THE PATENT COOPERATION TREATY (PCT)

(19) World Intellectual Property Organization
International Bureau(43) International Publication Date
16 February 2006 (16.02.2006)

PCT

(10) International Publication Number
WO 2006/016895 A1(51) International Patent Classification⁷: **B23P 19/00**,
H01R 43/00, H01B 5/00, 7/00, 7/29, 11/06, B23B 9/00,
15/00, 27/00, 31/00(74) Agents: HANEGAN, Herbert M. et al.; Smith, Gambrell
& Russell, LLP, 1230 Peachtree Street, N.E., Suite 3100,
Promenade II, Atlanta, Georgia 30309-3592 (US).(21) International Application Number:
PCT/US2005/005165(81) Designated States (unless otherwise indicated, for every
kind of national protection available): AE, AG, AL, AM,
AT, AU, AZ, BA, BB, BG, BR, BW, BY, BZ, CA, CH, CN,
CO, CR, CU, CZ, DE, DK, DM, DZ, EC, EE, EG, ES, FI,
GB, GD, GE, GH, GM, HR, HU, ID, IL, IN, IS, JP, KE,
KG, KP, KR, KZ, LC, LK, LR, LS, LT, LU, LV, MA, MD,
MG, MK, MN, MW, MX, MZ, NA, NI, NO, NZ, OM, PG,
PH, PL, PT, RO, RU, SC, SD, SE, SG, SK, SL, SM, SY,
TJ, TM, TN, TR, TT, TZ, UA, UG, US, UZ, VC, VN, YU,
ZA, ZM, ZW.(22) International Filing Date:
18 February 2005 (18.02.2005)

(25) Filing Language: English

(26) Publication Language: English

(30) Priority Data:
60/587,584 13 July 2004 (13.07.2004) US
10/952,294 28 September 2004 (28.09.2004) US(84) Designated States (unless otherwise indicated, for every
kind of regional protection available): ARIPO (BW, GH,
GM, KE, LS, MW, MZ, NA, SD, SL, SZ, TZ, UG, ZM,
ZW), Eurasian (AM, AZ, BY, KG, KZ, MD, RU, TJ, TM),
European (AT, BE, BG, CH, CY, CZ, DE, DK, EE, ES, FI,
FR, GB, GR, HU, IE, IS, IT, LT, LU, MC, NL, PL, PT, RO,
SE, SI, SK, TR), OAPI (BF, BJ, CF, CG, CI, CM, GA, GN,
GQ, GW, ML, MR, NE, SN, TD, TG).(71) Applicant (for all designated States except US): SOUTH-
WIRE COMPANY [US/US]; P.O. Box 1000, One South-
wire Drive, Carrollton, Georgia 30119 (US).

(72) Inventors; and

(75) Inventors/Applicants (for US only): KUMMER, Randy
D. [US/US]; 9059 River Bend Court, Villa Rica, Geor-
gia 30180 (US). REECE, David [US/US]; 10 Trellis
Court, Carrollton, Georgia 30117 (US). DIXON, Mark
D. [US/US]; 78 Riverridge Drive, Carrollton, Georgia
30117 (US). CARLSON, John R. [US/US]; 210 Primrose
Pass, Newnan, Georgia 30264 (US). LAM, Hai [US/US];
4173 Chapel Valley Drive, Douglasville, Georgia 30135
(US). SASSE, Philip [US/US]; 9455 Grace Lake Drive,
Douglasville, Georgia 30153 (US).

Published:

- with international search report
- with amended claims

Date of publication of the amended claims: 4 May 2006

For two-letter codes and other abbreviations, refer to the "Guid-
ance Notes on Codes and Abbreviations" appearing at the begin-
ning of each regular issue of the PCT Gazette.

(54) Title: ELECTRICAL CABLE HAVING A SURFACE WITH REDUCED COEFFICIENT OF FRICTION

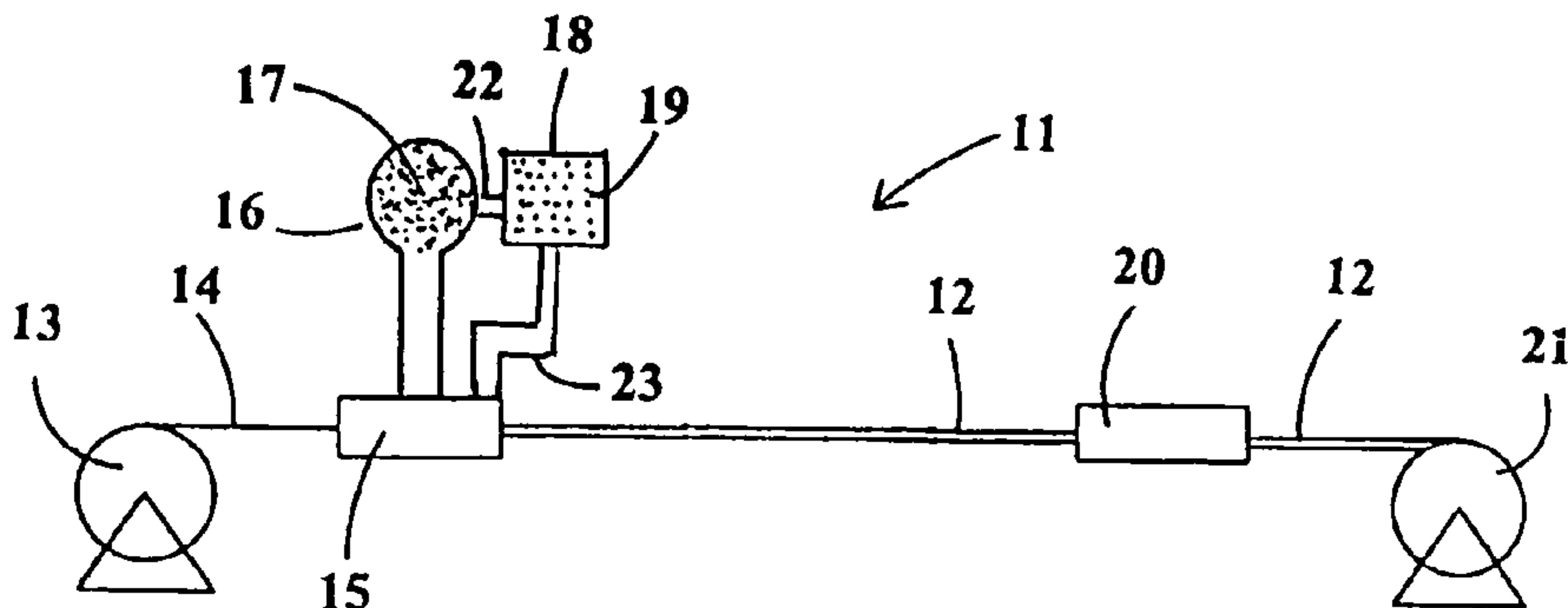

(57) Abstract: The mixture of plastic (17) and lubricating material (19) being coated on the electrical conductive wire or fiber optic wire by extruding head (15) to form an electrical cable or optical cable (12) having a surface with reduced coefficient of friction.

WO 2006/016895 A1

**ELECTRICAL CABLE HAVING A SURFACE WITH REDUCED
COEFFICIENT OF FRICTION**

TECHNICAL FIELD

[0001] The present invention relates to an electrical cable and to a method of and equipment for reducing its coefficient of friction.

BACKGROUND

[0002] Electrical cables which include at least one conductor core and at least one coating are well known.

[0003] Such cables present the disadvantage that their exterior surface has a high coefficient of friction, so that they are awkward to fit in internal sections of walls and ceilings or conduits, since when they come into contact with the surfaces they become stuck or difficult to pull, etc.

[0004] In order to overcome said difficulty, alternative materials such as vaselines and the like have been used to coat the exterior surface of the cable, thereby reducing the coefficient of friction.

[0005] In a complementary manner, guides of small diameter are sometimes used, one end of which is inserted through the cavity through which the cable has to pass and the other is attached to the end of the cable which must be inserted into the cavity. Thus, once the guide has emerged at the desired place it is pulled until the end of the cable appears again after having passed through the entire section.

[0006] In numerous fields of application, and in particular telecommunications, electric or fiber optic cables are inserted into ducts. There is therefore a need to minimize the coefficient of friction between cables and the inside walls of ducts.

[0007] In one solution, the core of the cable passes via a first extruder which applies a conventional sheath thereto i.e., a jacket and/or insulation, often made of polyethylene. The sheathed core then passes through a second extruder which applies a lubricant layer thereto,

such as an alloy of silicone resin and polyethylene. The cable lubricated in that way then passes in conventional manner through a cooling vessel.

[0008] A second solution provides for an extruder to cover the core of a cable with a sheath. At the outlet from that extruder there is disposed a coating chamber for applying granules of material to the still-hot sheath, which granules are designed to become detached when the cable is inserted in a duct. Finally, the coated cable passes through a cooling vessel.

[0009] In both of these two prior solutions, it is necessary to interpose additional equipment between the extruder and the cooling vessel. That gives rise to a major alteration of the manufacturing line.

[0010] In addition, the equipment for depositing the lubricant must be very close to the sheath extrusion head since otherwise it is not possible to control the thickness of the sheath properly. In any event, the additional equipment occupies non-negligible space and such an arrangement is not favorable for control over the dimensions of the sheath.

[0011] Whatever the prior art method used, the manufacture and/or installation of said cables involves a considerable loss of time and an economic cost, since alternative materials are required.

SUMMARY

[0012] The present invention thus seeks to provide a method for making a cable having a surface with reduced coefficient of friction that does not significantly alter the geometrical characteristics of the cable and the cable so produced.

[0013] The invention thus provides a method for incorporating a lubricant in the sheath of a cable, the sheath being made by means of an extruder and optionally followed by a cooling vessel.

[0013a] Certain exemplary embodiments can provide a method of providing an electrical cable, having a cable core and an external jacket with an exterior surface defining the outermost exterior surface of the cable, said method comprising during the manufacture of the said cable, extruding plastic material to form said external jacket, wherein: the electrical cable is for installation through building passageways; the jacket incorporates lubricating material that blooms, migrates toward the exterior surface of or permeates the jacket, the lubricating material being introduced into the jacket during or prior to the extruding; and the jacket contains sufficient lubricating material to provide a reduced coefficient of friction of the exterior surface of said external jacket sufficient to reduce the amount of force required to pull the cable through said passageways during its installation as compared to an electrical cable without the lubricating material.

[0013b] Certain exemplary embodiments can provide a method of installing an electrical cable through angled building conduits or passageways through internal sections of walls, ceilings, conduits, rafters or joists in a manner that reduces the amount of force required for such installation, said method comprising: (a) selecting a finished electrical cable having an outermost extruded protective jacket of preselected material surrounding a conductor core, the cable of the type in which a lubricant has been internally combined with the preselected jacket material in connection with the extrusion, and prior to the completion of formation of, the extruded jacket, the lubricant having been effective to migrate through, or permeate, the jacket to be available at the exterior surface of the jacket, and reduce the amount of force required to install the cable through the angled building conduits or passageways through the internal sections of walls, ceilings, conduits, rafters or joists, at the time the cable is to be installed; and (b) installing said cable in the building conduits or passageways without need of adding any additional external lubricant to the exterior surface besides said preselected internal lubricant.

[0013c] Certain exemplary embodiments can provide a method of providing a finished electrical cable for installation through angled building conduits or passageways through internal sections of walls, ceilings, conduits, rafters or joists, the cable having lubrication embodied in its outermost jacket sufficient to reduce the amount of force required to pull

the cable through said angled building conduits or passageways and without the need for additional lubrication at the exterior surface of said outermost jacket, the method comprising: (a) extruding only a single jacket of plastic material during the manufacture of the cable to surround at least an electrical conductor of the cable, said jacket also constituting the said outermost jacket of the cable; (b) introducing sufficient lubricant into said plastic material in connection with the extruding, and prior to the completion of formation of said single jacket to provide said reduced amount of force, such lubricant being of the type which either migrates through, or permeates, the said plastic material to be available at the exterior surface of said outermost jacket at the time of installation of the cable; and (c) providing said so-jacketed cable for its installation without need of adding any external lubrication to said jacket.

[0013d] Certain exemplary embodiments can provide a method of providing a finished electrical cable for installation through angled building conduits or passageways through internal sections of walls, ceilings, conduits, rafters or joists, the cable having lubrication embodied in its outermost jacket sufficient to reduce the amount of force required to pull the cable through the angled building conduits or passageways through the internal sections of walls, ceilings, conduits, rafters or joists, and without the need for additional lubrication at the exterior surface of said outermost jacket, the method comprising: (a) extruding a jacket of polyvinylchloride (PVC) material during the manufacture of the cable to surround at least an electrical conductor of the cable, said jacket also constituting the said outermost jacket of the cable; (b) introducing sufficient lubricant into said PVC material in connection with the extruding of the jacket prior to the completion of formation of said single jacket to provide said reduced amount of force, such lubricant being of the type which migrates through said PVC material to be available at the exterior surface of said outermost jacket at the time of said installation of the cable; and (c) providing said so-jacketed cable for its installation without need of adding any external lubrication to said jacket.

[0013e] Certain exemplary embodiments can provide in a method of manufacturing a finished electrical cable having at least one conductor and surrounding insulation and a jacket of plastic material surrounding said conductor and said insulation, with a step of extruding said jacket defining the outermost exterior surface of the finished cable, the method including: introducing sufficient lubricant into said material in connection with said extruding, and prior to the completion of formation of said jacket to reduce the amount of force required to pull the cable during its installation through angled building conduits or passageways through internal sections of walls, ceilings, conduits, rafters or joists in which said lubricant is of the type which migrates through said material to be available at the said outermost exterior surface during said installation.

[0013f] Certain exemplary embodiments can provide in a method of manufacturing a finished electrical cable having at least one conductor and surrounding insulation, and a protective jacket of plastic material surrounding said conductor and said insulation, said jacket defining the outermost exterior surface of the finished cable, the method including: forming said protective jacket; and introducing sufficient lubricant into said plastic material in connection with said forming, and prior to the completion of formation, of said protective jacket in order to reduce the amount of force required to pull the cable during its installation through angled building conduits or passageways through internal sections of walls ceilings, conduits, rafters or joists, in which said lubricant is of the type which permeates said material to be continuously available at the said outermost exterior surface during said installation.

[0013g] Certain exemplary embodiments can provide a method of manufacturing a finished electrical cable having a conductor core and a jacket of a first material, the jacket surrounding at least said conductor core and defining the outermost exterior surface of the finished cable, comprising combining a preselected lubricant with said first material in connection with the formation of the jacket , the lubricant being sufficient so as to reduce the amount of force required to install the cable through angled building passageways, and

of the type which migrates through said jacket to be available at said outermost exterior surface of said finished cable during the cable's installation through said angled building passageways.

[0013h] Certain exemplary embodiments can provide in a method of manufacturing a finished electrical cable having a conductor core and a jacket formed primarily of a first material, the jacket surrounding at least said conductor core and defining the outermost exterior surface of the finished cable, the method including combining a preselected lubricant with said first material in connection with, but prior to the completion of, the formation of the jacket, such that the force required to install the cable during its installation through angled building passageways through internal sections of walls, ceilings, conduits, rafters or joists is reduced, in which said lubricant is of the type which permeates said jacket to be continuously available at the said cable outermost exterior surface during its installation through said angled building passageways.

[0013i] Certain exemplary embodiments can provide in a method of manufacturing a finished electrical cable of the type having a conductor core, and an outermost jacket defining the exterior surface of the finished cable, the method including (a) extruding the outermost jacket, and (b) introducing a preselected lubricant in connection with the extruding of the jacket, of the type and sufficiency that enables the lubricant to either permeate, or migrate through, said jacket to be available at said cable exterior surface at the time of the finished cable's installation through angled building passageways through internal sections of walls, ceilings, conduits, rafters or joists, so as to reduce the amount of force required to install the finished cable through said building passageways.

[0013j] Certain exemplary embodiments can provide a method of manufacturing a finished electrical cable of the type having a conductor core and surrounding sheath of lubricated plastic material, the sheath defining the exterior surface of the cable, said method comprising: (a) preselecting a lubricant by both type and sufficiency to so interact with said preselected plastic material as to either migrate through or permeate said surrounding sheath and be available at the exterior surface of said sheath at the time of the

cable's installation, said lubricant further selected to be sufficient to reduce the amount of pulling force required to install the finished cable through angled building passageways or conduits with said lubricant from that pulling force required to install a finished electrical cable without said lubricant through said angled building passageways or conduits; (b) combining said lubricant with said plastic material; and (c) thereafter extruding the so combined lubricant and plastic material around said conductor core to form said lubricated sheath.

[0013k] Certain exemplary embodiments can provide the use of an electrical cable having a cable core and an external jacket with an exterior surface defining the outermost exterior surface of the cable wherein the external jacket of the cable is formed of extruded plastic material characterized in that: the electrical cable is utilised in installation through wall or ceiling cavities conduits or ducts; the cable core is comprised of an electrical conductor; the plastic material forming the external jacket comprises polyvinyl chloride (PVC); the jacket incorporates lubricating material that blooms, migrates toward the exterior surface of or permeates the jacket, the lubricating material being incorporated into the sheath during or prior to the extruding; and the jacket contains sufficient lubricating material to provide a reduced coefficient of friction of the exterior surface of said external jacket sufficient to reduce the amount of force required to pull the cable through said wall or ceiling cavities conduits or ducts during its installation.

[0014] In another embodiment, the lubricant material is mixed with the sheath material prior to either material being heated.

[0015] In another embodiment, the lubricant material is heated and mixed with the sheath material prior to the sheath material being heated.

[0016] In a further embodiment, the lubricant material is mixed with the sheath material after both materials have been heated.

[0017] In yet another embodiment, the non-heated lubricant material is mixed with heated sheath material.

[0018] As used herein the term sheath means a jacket and/or insulation applied to the core of a cable.

[0019] With the method and cable of various embodiments said disadvantages can be solved, while providing other advantages which will be described below.

[0020] The method for the manufacture of electrical cables is characterized in that it includes a step in which a lubricating material is mixed with the sheath material and this mixture is applied to the core of the cable.

[0021] A cable with low coefficient of friction is achieved thereby, so that subsequent installation of the same is considerably simplified, since it slides over the surfaces with which it comes into contact.

[0022] The step of mixing the lubricating material and the sheath material may be carried out with the lubricating material heated or not and the sheath material heated or not.

[0023] The sheath material normally is introduced in pellet form to an extruder which heats and directs the sheath material onto the cable or conductor core. The present invention includes the embodiment of incorporating the lubricating material into the sheath pellets during the formation of the sheath pellets and introducing this mixture of sheath pellets and lubricant material into an extruder, the embodiment of mixing the lubricant material with the sheath pellets and the embodiment of introducing this mixture into the extruder, and

introducing the sheath pellets into the extruder and subsequently introducing the lubricating material into the extruder prior to contacting the cable core.

[0024] Advantageously, the lubricant material is selected from the group consisting essentially of fatty amides, hydrocarbon oils, fluorinated organic resins, and mixtures thereof. The lubricant material may be incorporated at any point in the manufacturing process before the formation of the sheath, and depending upon the material, may be heated prior to mixing with the sheath material.

[0025] In instances where the sheath material has a high melting or softening temperature, or for other reasons such as processibility, efficiency of the process, etc. the lubricant material may be added to the sheath material as the sheath material is being formed. If the final cable construction is such that there are two or more different sheath materials applied to the cable core, the lubricant material need only be incorporated into the outermost sheath material.

[0026] Advantageous fatty amides and metallic fatty acids include, but are not limited to erucamide, oleamide, oleyl palmitamide, stearyl stearamide, stearamide, behenamide, ethylene bisstearamide, ethylene bisoleamide, stearyl erucamide, erucyl stearamide, and the like. Advantageous hydrocarbon oils include, but are not limited to, mineral oil, silicone oil, and the like. Lubricating materials suitable for the present invention further include plasticizers, dibasic esters, silicones, anti-static amines, organic amines, ethanolamides, mono- and di-glyceride fatty amines, ethoxylated fatty amines, fatty acids, zinc stearate, stearic acids, palmitic acids, calcium stearate, lead stearate, sulfates such as zinc sulfate, etc., and the like. The above lubricating materials may be used individually or in combination.

[0027] Suitable lubricating materials include fluorinated organic resins, such as a polymer of one or more fluorinated monomers selected from tetrafluoroethylene, vinylidene fluoride, chlorotrifluoroethylene and the like. The fluorinated resin is preferably used in the form of a powder, emulsion or aqueous dispersion.

[0028] The electrical cable is characterized in that it incorporates a lubricating material in the sheath coating, which lubricating material blooms, migrates toward the exterior, or permeates the cable sheath. If desired the sheath material may be somewhat porous, thereby resulting in the lubricating material more readily migrating toward the exterior surface of the sheath.

[0029] The sheath of the cable thus contains sufficient lubricating material to provide an exterior surface with reduced coefficient of friction.

[0030] The equipment for the manufacturing of electrical cables is characterized in that it may include a device for the incorporation of a lubricating material into the sheath material prior to application to the cable core.

[0031] Said equipment may also include a tank to maintain the lubricating material, a section for mixing the lubricating material and sheath material and a section for applying the mixture to the cable core.

[0032] Moreover, the equipment may also include a pressure adjusting valve(s), a level indicator(s) of the lubricating material tank and sheath material tanks, and a pressure gauge(s).

BRIEF DESCRIPTION OF THE DRAWINGS

[0034] FIG. 1 is a schematic elevation view of equipment for manufacturing electrical cable, according to the method of the present invention.

[0034a] FIG. 2 is a diagram illustrating a first type of joist-pull test apparatus used to characterize the present invention.

[0034b] FIG. 3 is a diagram illustrating a modified type of joist-pull test apparatus used to characterize the present invention.

DETAILED DESCRIPTION

[0035] As can be appreciated in Fig. 1, the equipment 11 for manufacturing electrical cable 12 of the present invention includes a reel 13 which supplies conductor wire 14 to an extruding head 15, which in turn includes a tank 16 of plastic material 17; a tank 18 of lubricating material 19 for mixture with plastic material 17 and for application onto the exterior surface of the conductor wire 14; a cooling box 20 for cooling the exterior surface of the plastic material 17 - lubricating material 19 mixture which is in a state of fusion or semi-fusion on the conductor wire or cable core 14; and a reel 21 for taking up the resulting cable 12.

[0036] As can be seen in Fig. 1, the tank 18 may include a section 22 through which the lubricating material can pass into tank 16 and be mixed with plastic material 17 and a section 23 through which lubricating material 19 can be introduced directly into extruding head 15 at a point after plastic material 17 has been introduced into extruding head 15.

[0037] Plastic material 17 includes known materials used in electrical wire and cable products such as polyethylene, polypropylene, polyvinylchloride, organic polymeric thermosetting and thermoplastic resins and elastomers, polyolefins, copolymers, vinyls, olefin-vinyl copolymers, polyamides, acrylics, polyesters, fluorocarbons, and the like.

[0038] The present inventive method and the novel cable produced thereby includes the step of coating conductor wire or cable core 14 with the mixture of plastic material 17 and lubricating material 19 and optionally cooling the coated cable formed thereby.

[0039] Cable 12 is thus obtained with at least one conducting core and an exterior coating, the main characteristic of which is that its coefficient of friction is low, which makes it easier to install since it slips on the surfaces with which it comes into contact.

[0040] Another beneficial property gained by the present invention is an increased resistance to "burn-through." "Burn-through," or "pull-by," results from friction generated by pulling one cable over another during installation, causing deterioration and eventual destruction to its own jacket as well as the jacket of the other cable. When using a lubricated cable of this invention the number of six-inch-stroke cycles required to produce burn-through was increased from 100 to 300.

[0041] The present inventive cable may also enhance ease in stripping the jacket from the cable end – termed stripability.

[0042] A further benefit of the present invention is the reduction of jacket rippling. Jacket rippling results from the friction of the jacket against building materials, causing the jacket material to stretch and bunch. Jacket damage may result. Installation situations, which repeatedly caused jacket rippling in unlubricated cable caused no rippling in lubricated cable jackets.

[0043] Despite the fact that reference has been made to specific embodiments of the invention, it will be clear to experts in the subject that the cable, the method and the equipment described can be varied and modified in many ways, and that all the details mentioned can be replaced by others which are technically equivalent without departing from the sphere of protection defined by the attached claims.

[0044] For example, cable 12 on which plastic material 17 and lubricating material 19 are applied can be of any desired configuration and can be an optical fiber cable or the like.

[0045] It has been found experimentally that the use of a lubricating material disclosed herein is suitable for providing a considerable reduction of the coefficient of friction of the cable, which means that it is easier to install without adding any external element to it, which is one of the objectives sought in the present invention.

EXAMPLE

[0046] To understand the affects of the jacket lubricant system on the ease of pull variations of the UL (Underwriters Laboratories, Inc.) joist pull test was utilized.

[0047] The joist pull test outlined in UL 719 Section 23 establishes the integrity of the outer PVC jacket of Type NM-B constructions when subjected to pulling through angled holes drilled through wood blocks.

[0048] The first variation of the test apparatus (see Fig. 2) consists of an arrangement of 2"x4" wood blocks having holes drilled at 15° drilled through the broad face. Four of these blocks are then secured into a frame so that the centerlines of the holes are offset 10" to create tension in the specimen through the blocks. A coil of NM-B is placed into a cold-box and is conditioned at -20°C for 24 hours. A section of the cable is fed through corresponding holes in the blocks where the end protruding out of the last block is pulled through at 45° to the horizontal. The cable is then cut off and two other specimens are pulled through from the coil in the cold-box. Specimens that do not exhibit torn or broken jackets and maintain conductor spacing as set fort in the Standard are said to comply.

[0049] Pulling wire through the wood blocks provides a more direct correlation of the amount of force required to pull NM-B in during installation. Because of this relationship, the joist-pull test is initially the basis for which ease of pulling is measured, but a test for quantifying this "ease" into quantifiable data had to be established.

[0050] Accordingly, and as shown in Fig. 3, a variable-speed device was introduced to pull the cable specimen through the blocks. An electro-mechanical scale was installed between the specimen and the pulling device to provide a readout of the amount of force in the specimen. To create back tension a mass of known weight (5-lbs) was tied to the end of the specimen.

[0051] Data recorded proved that NM-B constructions having surface lubricates reduced pulling forces.

[0052] A 12-V constant speed winch having a steel cable and turning sheave was employed; the turning sheave maintains a 45 degree pulling angle and provides a half-speed to slow the rate of the pulling so that more data points could be obtained. Holes were drilled in rafters whereby specimens could be pulled by the winch.

[0053] It was found using this method that lubricated specimens yielded approximately a 50% reduction in pulling force when compared to standard, non-lubricated NM-B specimens. The results are shown in Tables 1 and 2 wherein the data was recorded at five second intervals.

TABLE 1

Test Pt. Descr.	Specimen Description								
	Manufacturer A1	Manufacturer A2	Manufacturer A3	Manufacturer B1	Manufacturer B2	Manufacturer B3	Control 1	Control 2	Present Invention
1st Point	26.8	48.3		37.8	37.4		16.5	41.9	24
2nd Point	34.6	51.1		35.2	38.1		41.6	42	20.5
3rd Point	33.7	46.8		32	33		40.2	38.7	20
4th Point	38.6	49.8		34.7	34.6		41.3	29.5	17.4
5th Point	33.1	44.8		34.2	32.5		41.3	34.3	20.2
6th Point	28.6	44.7		32.2	33.2		42.5	35.9	15.8
7th Point	5.5	51		32.2	33.9		41.1	37	17.2
8th Point	26.8	49.2		33.9	33		40.9	38.4	17.3
9th Point	21.9	52.5		32.6	30.6		42.7	37.3	21.9
Average	30.51	48.69		33.87	34.03		41.45	37.22	19.37

AAA - Denotes Outliers

Test in Table 1 performed at a constant speed with winch using 1/2 speed pulley

Test in Table 2 performed on cable with a 5# weight suspended at building entry

Std. Prod.

Average

37.6289

Present Invention

19.37

TABLE 2

Test Pt. Descr.	Specimen Description						
	Manufacturer A 14-2	Manufacturer B 14-2	Control 1 14-2/12-2	Control 2 14-2/12-2	Control 3 14-2/12-2	Invention A 14-2/12-2	Invention B 14-2/12-2
1st Point	34	32.6	50	47.5	40.2	21.5	12.3
2nd Point	35	35.7	50.6	38.3	37.5	22.9	12.8
3rd Point	35.5	31.2	46.7	43.2	27.5	29	12.1
4th Point	37.7	35	44.5	46	36.8	22.4	14.9
5th Point	40.5	30.6	46.2	39.5	36	23.3	11.9
6th Point	32.9	28.8	40.9	35.7	41.2	21.1	12.5
7th Point	44.2	32.4	52.8	37.5	37	21.6	11.7
8th Point	43	32.4	40.7	27.7	31.7	22.5	11.7
9th Point	43.4	30.5	40	31.1		19.2	11
10th Point	40						11.6
Average	38.62	32.13	45.82	38.50	35.99	22.61	12.25

14-2/12-2
Control Avg.
40.103241

14-2/12-2
Invention A
22.61

14-2/12-2
Invention B
12.25

TABLE 2

Test Pt. Descr.	Specimen Description						
	Manufacturer A 14-2	Manufacturer B 14-2	Control 1 14-2/12-2	Control 2 14-2/12-2	Control 3 14-2/12-2	Invention A 14-2/12-2	Invention B 14-2/12-2
1st Point	34	32.6	50	47.5	40.2	21.5	12.3
2nd Point	35	35.7	50.6	38.3	37.5	22.9	12.8
3rd Point	35.5	31.2	46.7	43.2	27.5	29	12.1
4th Point	37.7	35	44.5	46	36.8	22.4	14.9
5th Point	40.5	30.6	46.2	39.5	36	23.3	11.9
6th Point	32.9	28.8	40.9	35.7	41.2	21.1	12.5
7th Point	44.2	32.4	52.8	37.5	37	21.6	11.7
8th Point	43	32.4	40.7	27.7	31.7	22.5	11.7
9th Point	43.4	30.5	40	31.1		19.2	11
10th Point	40						11.6
Average	38.62	32.13	45.82	38.50	35.99	22.61	12.25

14-2/12-2
Control Avg.
40.103241

14-2/12-2
Invention A
22.61

14-2/12-2
Invention B
12.25

Claims:

1. A method of providing an electrical cable, having a cable core and an external jacket with an exterior surface defining the outermost exterior surface of the cable, said method comprising during the manufacture of the said cable, extruding plastic material to form said external jacket, wherein:

the electrical cable is for installation through building passageways;

the jacket incorporates lubricating material that blooms, migrates toward the exterior surface of or permeates the jacket, the lubricating material being introduced into the jacket during or prior to the extruding; and

the jacket contains sufficient lubricating material to provide a reduced coefficient of friction of the exterior surface of said external jacket sufficient to reduce the amount of force required to pull the cable through said passageways during its installation as compared to an electrical cable without the lubricating material.

2. The method as defined by Claim 1, in which the introduction of said lubricating material is effected by combining said lubricating material with said plastic material in non-pellet form, thereby to form sufficiently lubricated material pellets, and the so-lubricated material pellets are thereafter used for said extruding.

3. The method as defined in Claim 1, in which said introduction is effected by injecting said plastic material in non-lubricated form into an extruding head at a first location and injecting the said selected lubricating material into said extruding head at a second location downstream from said first location, while extruding said jacket through said extruding head.

4. The method as defined in Claim 1, in which said introduction is effected by combining said preselected lubricating material with pellets of said plastic material, and extruding the jacket with use of the so-lubricated material pellets.

5. The method as defined by any one of Claims 1 to 4, in which the plastic material is polyvinylchloride (PVC).

6. The method as defined by any one of Claims 1 to 5, in which the cable core includes at least one electrical conductor, and the plastic material is extruded directly onto said at least one electrical conductor.
7. The method as defined by any one of Claims 1 to 6, in which the external jacket surrounds the cable core.
8. The method as defined by any one of Claims 1 to 7, in which said lubricating material is a fatty amide.
9. The method as defined by any one of Claims 1 to 8, in which the reduction of the required force for installation through said building passageways is at least approximately 30% of the force required to install non-lubricated cable of the same cable type.
10. The method as defined in any one of Claims 1 to 9, in which said building passageways are internal sections of walls and ceilings.
11. The method as defined in any one of Claims 1 to 10, in which said building passageways are conduits.
12. The method as defined in any one of Claims 1 to 11, in which said building passageways are ducts.
13. The method as defined in any one of Claims 1 to 12, wherein the finished electrical cable has the characteristic that an amount of force required to install said cable through corresponding holes in an arrangement of four 2"x4" wood blocks having holes drilled at 15° through the broad face and the centerlines of the holes are offset 10" and pulled through at 45° to the horizontal from the last block is a consideration reduction in comparison to an amount of force required to install a non-lubricated cable of the same cable type and size through corresponding holes in said arrangement.

14. The method as defined by Claim 13, wherein the reduction in the amount of force is at least about 30% .

15. The method as defined by Claim 13, wherein the reduction in the amount of force is at least about 50% .

16. A method of installing an electrical cable through angled building conduits or passageways through internal sections of walls, ceilings, conduits, rafters or joists in a manner that reduces the amount of force required for such installation, said method comprising:

(a) selecting a finished electrical cable having an outermost extruded protective jacket of preselected material surrounding a conductor core, the cable of the type in which a lubricant has been internally combined with the preselected jacket material in connection with the extrusion, and prior to the completion of formation of, the extruded jacket, the lubricant having been effective to migrate through, or permeate, the jacket to be available at the exterior surface of the jacket, and reduce the amount of force required to install the cable through the angled building conduits or passageways through the internal sections of walls, ceilings, conduits, rafters or joists, at the time the cable is to be installed; and

(b) installing said cable in the building conduits or passageways without need of adding any additional external lubricant to the exterior surface besides said preselected internal lubricant.

17. A method of providing a finished electrical cable for installation through angled building conduits or passageways through internal sections of walls, ceilings, conduits, rafters or joists, the cable having lubrication embodied in its outermost jacket sufficient to reduce the amount of force required to pull the cable through said angled building conduits or passageways and without the need for additional lubrication at the exterior surface of said outermost jacket, the method comprising:

- (a) extruding only a single jacket of plastic material during the manufacture of the cable to surround at least an electrical conductor of the cable, said jacket also constituting the said outermost jacket of the cable;
- (b) introducing sufficient lubricant into said plastic material in connection with the extruding, and prior to the completion of formation of said single jacket to provide said reduced amount of force, such lubricant being of the type which either migrates through, or permeates, the said plastic material to be available at the exterior surface of said outermost jacket at the time of installation of the cable; and
- (c) providing said so-jacketed cable for its installation without need of adding any external lubrication to said jacket.

18. The method as defined by Claim 17, in which the introduction of said lubricant into said plastic material in connection with the extruding is effected by combining said plastic material in non-pellet form with said lubricant, thereby to form sufficiently lubricated material pellets, and the so-lubricated material pellets are thereafter used for said extruding.

19. A method of providing a finished electrical cable for installation through angled building conduits or passageways through internal sections of walls, ceilings, conduits, rafters or joists, the cable having lubrication embodied in its outermost jacket sufficient to reduce the amount of force required to pull the cable through the angled building conduits or passageways through the internal sections of walls, ceilings, conduits, rafters or joists, and without the need for additional lubrication at the exterior surface of said outermost jacket, the method comprising:

- (a) extruding a jacket of polyvinylchloride (PVC) material during the manufacture of the cable to surround at least an electrical conductor of the cable, said jacket also constituting the said outermost jacket of the cable;
- (b) introducing sufficient lubricant into said PVC material in connection with the extruding of the jacket prior to the completion of formation of said single jacket to provide said reduced amount of force, such lubricant being of the type which migrates through said PVC material to be available at the exterior surface of said outermost jacket at the time of said installation of the cable; and

(c) providing said so-jacketed cable for its installation without need of adding any external lubrication to said jacket.

20. In a method of manufacturing a finished electrical cable having at least one conductor and surrounding insulation and a jacket of plastic material surrounding said conductor and said insulation, with a step of extruding said jacket defining the outermost exterior surface of the finished cable, the method including:

introducing sufficient lubricant into said material in connection with said extruding, and prior to the completion of formation of said jacket to reduce the amount of force required to pull the cable during its installation through angled building conduits or passageways through internal sections of walls, ceilings, conduits, rafters or joists in which said lubricant is of the type which migrates through said material to be available at the said outermost exterior surface during said installation.

21. In a method of manufacturing a finished electrical cable having at least one conductor and surrounding insulation, and a protective jacket of plastic material surrounding said conductor and said insulation, said jacket defining the outermost exterior surface of the finished cable, the method including:

forming said protective jacket; and

introducing sufficient lubricant into said plastic material in connection with said forming, and prior to the completion of formation, of said protective jacket in order to reduce the amount of force required to pull the cable during its installation through angled building conduits or passageways through internal sections of walls ceilings, conduits, rafters or joists, in which said lubricant is of the type which permeates said material to be continuously available at the said outermost exterior surface during said installation.

22. A method of manufacturing a finished electrical cable having a conductor core and a jacket of a first material, the jacket surrounding at least said conductor core and defining the outermost exterior surface of the finished cable, comprising combining a preselected lubricant with said first material in connection with the formation of the jacket, the lubricant being sufficient so as to reduce the amount of force required to

install the cable through angled building passageways, and of the type which migrates through said jacket to be available at said outermost exterior surface of said finished cable during the cable's installation through said angled building passageways.

23. The method as defined by Claim 22, in which the angled building passageways are through internal sections of walls and ceilings of the building.

24. The method as defined by Claim 22, in which the angled building passageways are through one or more of the rafters, joists or angled conduits of the building.

25. In a method of manufacturing a finished electrical cable having a conductor core and a jacket formed primarily of a first material, the jacket surrounding at least said conductor core and defining the outermost exterior surface of the finished cable, the method including combining a preselected lubricant with said first material in connection with, but prior to the completion of, the formation of the jacket, such that the force required to install the cable during its installation through angled building passageways through internal sections of walls, ceilings, conduits, rafters or joists is reduced, in which said lubricant is of the type which permeates said jacket to be continuously available at the said cable outermost exterior surface during its installation through said angled building passageways.

26. The method as defined by Claim 25, in which the angled building passageways are through internal sections of walls and ceilings of the building.

27. The method as defined by Claim 25, in which the angled building passageways are through rafters of the building.

28. The method as defined by Claim 25, in which the angled building passageways are through joists of the building.

29. The method as defined by Claim 25, in which the preselected lubricant is such as to reduce the required force for installation of the cable through the angled building passageways and through angled building conduits.

30. The method as defined in Claim 21 or Claim 25, in which said combining is effected by combining said preselected lubricant with said first material in non-pellet form, thereby to form lubricated material pellets, and extruding the jacket with use of the so-lubricated material pellets.

31. The method as defined in Claim 21 or Claim 25, in which said combining is effected by injecting said first material in non-lubricated form into an extruding head at a first location and injecting the said preselected lubricant into said extruding head at a second location downstream from said first location, while extruding said jacket through said extruding head.

32. The method as defined in Claim 21 or Claim 25, in which said combining is effected by combining said preselected lubricant with pellets of said first material, and extruding the jacket with use of the so-lubricated material pellets.

33. In a method of manufacturing a finished electrical cable of the type having a conductor core, and an outermost jacket defining the exterior surface of the finished cable, the method including (a) extruding the outermost jacket, and (b) introducing a preselected lubricant in connection with the extruding of the jacket, of the type and sufficiency that enables the lubricant to either permeate, or migrate through, said jacket to be available at said cable exterior surface at the time of the finished cable's installation through angled building passageways through internal sections of walls, ceilings, conduits, rafters or joists, so as to reduce the amount of force required to install the finished cable through said building passageways.

34. The method as defined by any one of Claims 16, 17, 19, 20, 21, 22, 25, or 33, in which the finished electrical cable additionally has the characteristic that an amount of force required to install said cable through corresponding holes in an arrangement of four 2"x4" wood blocks, with the holes being drilled at an angle through the broad face and the centerlines of the holes offset, and the cable pulled through at an angle to the horizontal from the last block, is less than the amount of force required to install a non-lubricated cable of the same cable type and size through corresponding holes in said arrangement.

35. A method of manufacturing a finished electrical cable of the type having a conductor core and surrounding sheath of lubricated plastic material, the sheath defining the exterior surface of the cable, said method comprising:

(a) preselecting a lubricant by both type and sufficiency to so interact with said preselected plastic material as to either migrate through or permeate said surrounding sheath and be available at the exterior surface of said sheath at the time of the cable's installation, said lubricant further selected to be sufficient to reduce the amount of pulling force required to install the finished cable through angled building passageways or conduits with said lubricant from that pulling force required to install a finished electrical cable without said lubricant through said angled building passageways or conduits;

(b) combining said lubricant with said plastic material; and

(c) thereafter extruding the so combined lubricant and plastic material around said conductor core to form said lubricated sheath.

36. The method of manufacturing defined by Claim 35, further including the step of verifying, after said extruding, that the installation pulling force had been reduced, said verifying being by quantifiably determining the ease of pulling said finished electrical cable.

37. The use of an electrical cable having a cable core and an external jacket with an exterior surface defining the outermost exterior surface of the cable wherein the external jacket of the cable is formed of extruded plastic material characterized in that:

the electrical cable is utilised in installation through wall or ceiling cavities conduits or ducts;

the cable core is comprised of an electrical conductor;

the plastic material forming the external jacket comprises polyvinyl chloride (PVC);

the jacket incorporates lubricating material that blooms, migrates toward the exterior surface of or permeates the jacket, the lubricating material being incorporated into the sheath during or prior to the extruding; and

the jacket contains sufficient lubricating material to provide a reduced coefficient of friction of the exterior surface of said external jacket sufficient to reduce the amount of force required to pull the cable through said wall or ceiling cavities conduits or ducts during its installation.

38. The use as defined by Claim 37, in which the introduction of said lubricating material is into said plastic material and is effected by combining said lubricating material with said plastic material in non-pellet form, thereby to form sufficiently lubricated material pellets, and the so-lubricated material pellets are thereafter used for said extruding.

39. The use as defined in claim 37, in which said introduction is effected by injecting said plastic material in non-lubricated form into an extruding head at a first location and injecting the said selected lubricating material into said extruding head at a second location downstream from said first location, while extruding said jacket through said extruding head.

40. The use as defined in claim 37, in which said introduction is effected by combining said preselected lubricating material with pellets of said plastic material, and extruding the jacket with use of the so-lubricated material pellets.

41. The use as defined by any one of claims 37 to 40 in which the cable core includes at least one electrical conductor.

42. The use as defined by any one of claims 37 to 41 in which the reduction of the required force for installation is at least approximately 50% of the force required to install non-lubricated cable of the same cable type.

43. The use as defined in any one of claims 37 to 42 in which the installation is through the internal section of a wall or ceiling.

44. The use as defined in any one of claims 37 to 43 in which the installation is through a conduit.

45. The use as defined in any one of claims 37 to 44 in which the installation is through a duct.

46. The use as defined in any one of claims 37 to 45 in which said lubricating material is comprised of a fatty amide.

FIG. 1

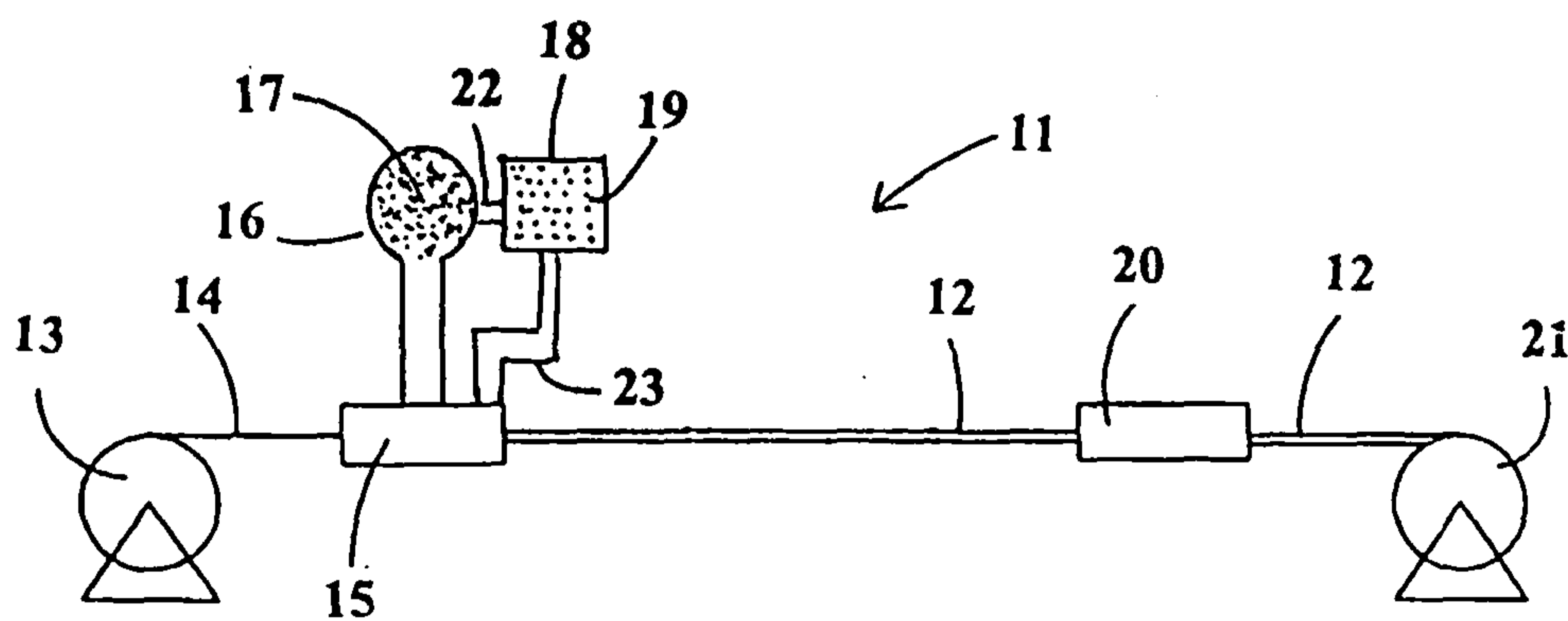

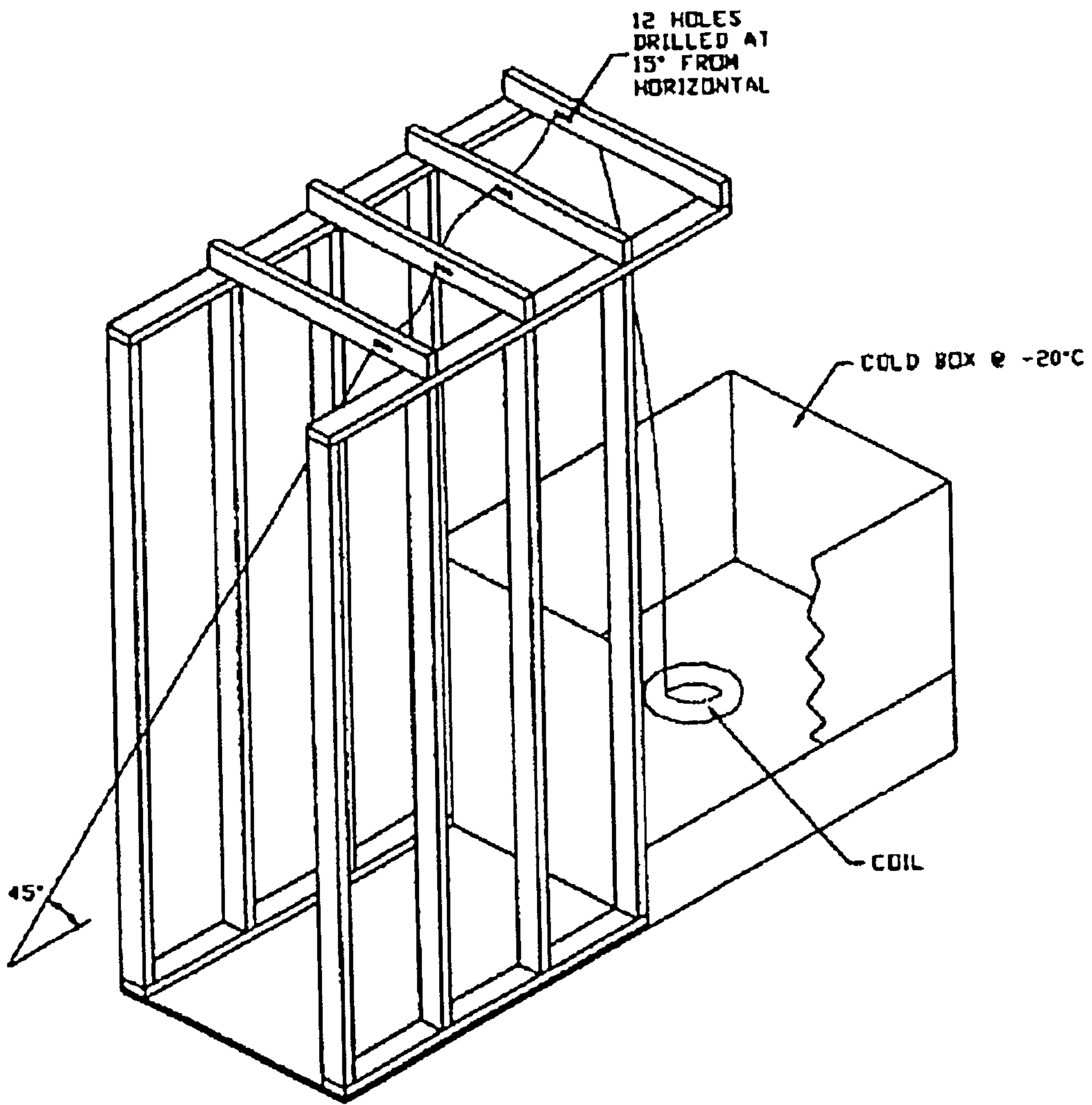

FIG. 2

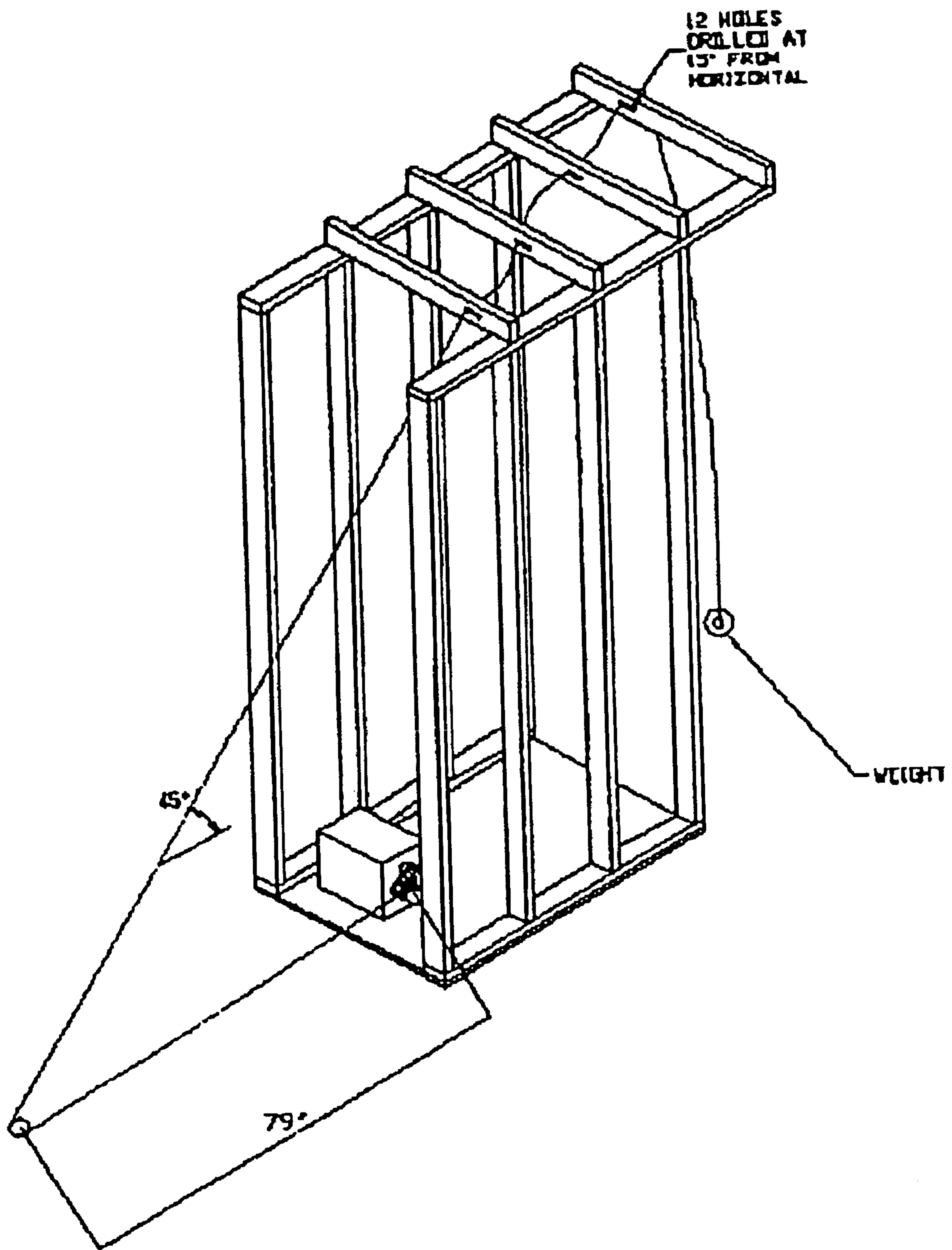

FIG. 3

