

(19) World Intellectual Property Organization
International Bureau



(43) International Publication Date
3 June 2011 (03.06.2011)

(10) International Publication Number
WO 2011/063820 A1

(51) International Patent Classification:
F16B 5/06 (2006.01)

(21) International Application Number:
PCT/EP2009/008362

(22) International Filing Date:
24 November 2009 (24.11.2009)

(25) Filing Language: English

(26) Publication Language: English

(71) Applicant (for all designated States except US):
RAIMUND BECK NAGELTECHNIK GMBH
[AT/AT]; Biburg 1, A-5270 Mauerkirchen (AT).

(72) Inventor; and

(75) Inventor/Applicant (for US only): **SIEMERS, Stefan**
[DE/DE]; Dr. Wolfgang-Gruber-Strasse 11, 84489
Burghausen (DE).

(74) Agents: **PAUL, Dieter, Alfred** et al.; Paul & Albrecht,
Hellersbergstrasse 18, 41460 Neuss (DE).

(81) Designated States (unless otherwise indicated, for every
kind of national protection available): AE, AG, AL, AM,

AO, AT, AU, AZ, BA, BB, BG, BH, BR, BW, BY, BZ,
CA, CH, CL, CN, CO, CR, CU, CZ, DE, DK, DM, DO,
DZ, EC, EE, EG, ES, FI, GB, GD, GE, GH, GM, GT,
HN, HR, HU, ID, IL, IN, IS, JP, KE, KG, KM, KN, KP,
KR, KZ, LA, LC, LK, LR, LS, LT, LU, LY, MA, MD,
ME, MG, MK, MN, MW, MX, MY, MZ, NA, NG, NI,
NO, NZ, OM, PE, PG, PH, PL, PT, RO, RS, RU, SC, SD,
SE, SG, SK, SL, SM, ST, SV, SY, TJ, TM, TN, TR, TT,
TZ, UA, UG, US, UZ, VC, VN, ZA, ZM, ZW.

(84) Designated States (unless otherwise indicated, for every
kind of regional protection available): ARIPO (BW, GH,
GM, KE, LS, MW, MZ, NA, SD, SL, SZ, TZ, UG, ZM,
ZW), Eurasian (AM, AZ, BY, KG, KZ, MD, RU, TJ,
TM), European (AT, BE, BG, CH, CY, CZ, DE, DK, EE,
ES, FI, FR, GB, GR, HR, HU, IE, IS, IT, LT, LU, LV,
MC, MK, MT, NL, NO, PL, PT, RO, SE, SI, SK, SM,
TR), OAPI (BF, BJ, CF, CG, CI, CM, GA, GN, GQ, GW,
ML, MR, NE, SN, TD, TG).

Published:

— with international search report (Art. 21(3))

(54) Title: SCREW NAIL

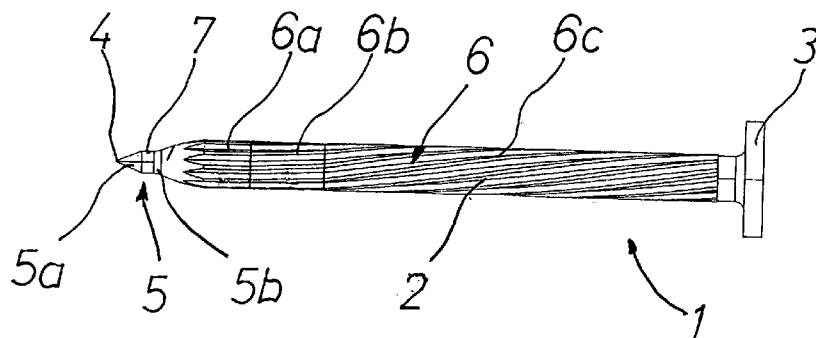

FIG. 1

(57) Abstract: The present invention relates to a screw nail (1) for connecting plane components in dry construction by means of an automatic nailer, in particular for fixing surface elements onto a metallic substructure. The screw nail has a shaft (2) with a head (3), and on the other end a hole formation region (5) extending to a point (4). The shaft (2) is provided with a knurling (6), having a first knurling section (6a), in a region of the shaft (2) adjacent to the hole formation region (5) in which the knurling (6) extends substantially parallel to a central axis of the shaft (2), and at least one second knurling section (6b) adjacent to the latter, in which an angle of elevation of the knurling (6) formed between the central axis of the shaft (2) and the knurling (6) increasing constantly towards the head (3).



WO 2011/063820 A1

DESCRIPTION**Screw Nail**

The present invention relates to a screw nail for connecting plane components in dry construction by means of an automatic nailer, in particular for fixing surface elements onto a metallic substructure, the screw nail having a shaft on one end region of which a head, and on the other end region of which a deformation region extending to a point or to a shape similar to a point is formed, the shaft being provided with a knurling.

When attaching plasterboard panels onto metal substructures using positioning nails, loose joints are often produced which are due to insufficient interlocking of the attachment means and the supporting substructure. Upon close examination it is shown that a technically satisfactory hold is generally only produced by the attachment means not being driven in at exact right angles to the surface, but by being at different angles to one another, thus preventing one another from slipping out of the components to be attached. Alternatively one can use screw nails which are subjected to a rotational movement after being inserted into the material to be joined.

Screw nails of the type specified above are generally known. Therefore, for example, a nail is known from German utility model DE 7 805 747 which has a substantially cylindrical, knurled shaft and is used to attach surface elements, such as for example plasterboard panels, onto metallic components. The knurling of the nail shown in this publication extends substantially parallel to an axial extension of the shaft of the nail.

In order to achieve a rotatory movement of the screw nail in addition to a translatory movement implemented by the positioning device, and so to reduce the risk of undesired loosening of the nail, after being driven in by means of an automatic nailer, in a subsequent procedural step the nail can be subjected manually to a rotational movement.

Alternatively, it is also possible to use an automatic nailer which implements both translatory and rotatory movements. However, a disadvantage with such positioning devices is that the latter require substantially more time to drive the nail into the components to be joined together in comparison to purely translatory automatic nailers due to the implementation of rotatory movements and also due to the change between the translatory and the rotatory movement, and are also more expensive than purely translatory nail positioning devices.

In document DE 4 312 868 C1 a plastic nail for light-weight and porous concrete is shown. For better fixing of the nail it is proposed to form, in addition to anchoring plates and axially extending displacement grooves beneath the nail head, radially extending wings which have a circumferential component designed to have increasing strength towards the head and providing angular momentum to the nail as it is driven in. However, the production of these wings is very complex and expensive.

Furthermore, the nail is not suitable for penetrating harder materials, such as for example sheet metal substructures, and so the attachment of plasterboard panels onto metal substructures is not possible, and its use is restricted to the attachment of objects onto light-weight or porous concrete. It is also only possible with great difficulty to drive in the nails using an automatic nailer due to the forces acting on the nail when penetrating the metal substructure.

Therefore, it is the object of the present invention to provide a screw nail which can be driven in reliably by means of an automatic nailer simply with a translatory movement and which has improved pull-out values.

This object is achieved according to the invention in that the shaft has a first knurling section, in particular in a region of the shaft adjacent to the hole formation region in which the knurling extends substantially

parallel to a central axis of the shaft, and at least one second knurling section adjacent to the latter, in which an angle of elevation of the knurling formed between the central axis of the shaft and the knurling increasing constantly towards the head.

In other words, by providing knurling on the shaft of the screw nail with a constantly increasing angle of elevation, it is achieved that when being driven in, the screw nail implements a constantly increasing rotation movement as it penetrates more deeply into the components to be joined together due to the constantly increasing angle of elevation of the knurling. By providing a rotational movement of the screw nail it is achieved that the screw nail rotates more softly into the components to be joined together, or at least experiences elastic rotational pre-tensioning which leads to the pull-out values of the screw nail being substantially improved. The first knurling section extending parallel to the central axis of the shaft provides stabilisation and maintenance of the positioning direction of the screw nail and the insertion of a thread-type structure into the material penetrated by the latter, and thus guarantees that the screw nail also engages in the material and in this way initiates a subsequent automatic rotational movement of the screw nail in the material.

Trials have shown that optimal rotational properties of the screw nail are achieved if a maximum angle of eleva-

tion in the second or subsequent knurling section of the knurling relative to the central axis of the shaft comes within the range between 3° and 50° , preferably within the range between 10° and 20° , even more preferably is 14° .

In a further exemplary embodiment of the invention the knurling has a number of knurling sections, the second or a third knurling section having an uneven increase along the shaft.

A particularly homogeneous movement of the screw nail within the components to be joined together is achieved if a profile of the knurling is disposed distributed evenly around the circumference of the shaft.

The number of threads of the knurling distributed around the circumference can be between 3 and 30, preferably in the range between 5 and 20, more preferably 10.

Here a profile depth of the knurling can decrease towards the point and come within the range between 0.01 and 0.15 mm.

In order to enable a particularly even crossover and the most impact-free possible penetration of the knurling into the components to be joined together, in one exemplary embodiment provision is made in the hole formation region, in order to gently expand the components to be

penetrated, to form sections tapering towards the point, of which at least two of the sections have different degrees of tapering in relation to one another.

Particularly gentle penetration of the screw nail into the components to be penetrated is achieved by the hole formation region being at least partially ogival in form.

Alternatively, the hole formation region can also be at least partially conical or ballistic in form.

In order to keep residual stresses caused by expansion of the inlet opening of the plane material as small as possible, in one exemplary embodiment provision is made such that two sections formed in the hole formation region are connected to one another respectively by means of an intermediate stage which is in particular cylindrical. In this way it is achieved that the hole expansion takes place in stages, and between the expansions by means of the cylindrical intermediate stages the material is given the possibility of flowing, and so residual stresses are broken down, at least in some regions.

Further advantageous embodiments of the present invention are given by the sub-claims and by the following drawing.

This shows as follows:

Figure 1 a screw nail according to the invention.

The single figure shows a screw nail 1 according to the invention for connecting plane components in dry construction by means of a high-speed automatic nailing device. The screw nail serves to fix surface elements onto a metallic substructure, as generally known in dry construction. The screw nail 1 according to the invention has a shaft 2 on one end region of which a head 3, and on the other end region of which a hole formation region 5 extending to a point 4 or to a shape similar to a point are formed.

On the shaft 2 a knurling 6 comprising ten knurling sides distributed evenly around the circumference of the shaft is formed. Furthermore, in this exemplary embodiment of the invention the knurling 6 is distributed over three knurling sections 6a, 6b, 6c. In the first knurling section 6a the knurling 6 extends constantly, substantially parallel to the central axis of the shaft 2. In this knurling section 6a the angle of elevation formed between the central axis of the shaft 2 and the knurling 6 is substantially 0°. This parallel alignment of the knurling section 6a leads to even penetration into the components to be joined together and to uniform acceleration of the screw nail 1, thus stabilising the direction of driving in. The knurling section 6a of the knurling 6 further ensures that the screw nail 1 gains a better hold in the components to be attached and introduces a thread-like structure into the material penetrated by it, and so

guarantees that the screw nail 1 also engages in the material to be joined together.

In order to also add a rotatory component to the translatory movement of the screw nail 1 in order to thus improve the pull-out values of the screw nail 1, the angle of elevation of the knurling in the second knurling section 6b for initiating a rotational movement of the screw nail 1 initially increases slightly by a few degrees in order then, in the third knurling section 6c, to more greatly increase knurling 6 towards the head 3. The maximum angle of elevation of the knurling 6 according to the screw nail 1 shown in relation to the central axis of the shaft 2 is 14° . Here the knurling 6 is introduced into the shaft 2 in an anti-clockwise direction, but can, if required, also alternatively be arranged in a clockwise direction.

By providing the third knurling section 6c with a strongly increasing angle of elevation, the screw nail 1 implements a rotation movement which leads to the pull-out values of the screw nail 1 within the components to be joined together being considerably improved.

Furthermore, the screw nail 1 according to the invention has special shaping of the point 4. Here the screw nail 1 has a penguin- or dolphin-shaped point 4. The technical effect of this is that when penetrating the components to be joined together, the material of the compo-

nents is expanded in two stages. This means that in the region of the knurling 6 the screw nail 1 engages quickly and reliably in the components to be joined together. For this purpose, with the first, very sharp point 4 the material is first of all broken through, whereas it can be expanded with the second part of the point 5a, 5b. In this way the sheet metal material is opened more gently than with conventional point geometry. For this purpose the two sections 5a, 5b formed in the hole formation region 5 are connected to one another by means of a cylindrical intermediate stage 7.

CLAIMS

1. A screw nail (1) for connecting plane components in dry construction by means of an automatic nailer, in particular for fixing surface elements onto a metallic substructure, the screw nail having a shaft (2) on one end region of which a head (3), and on the other end of which a hole formation region (5) extending to a point (4) or to a shape similar to a point (5) are formed, the shaft (2) being provided with a knurling (6), **characterised in that** the shaft (2) has a first knurling section (6a), in particular in a region of the shaft (2) adjacent to the hole formation region (5) in which the knurling (6) extends substantially parallel to a central axis of the shaft (2), and at least one second knurling section (6a) adjacent to the latter, in which an angle of elevation (5) of the knurling (6) formed between the central axis of the shaft (2) and the knurling (6) increasing constantly towards the head (3).

2. The screw nail (1) according to claim 1, **characterized in that** a maximum angle of elevation of the knurling (6) relative to the central axis of the shaft (2) comes within the range between 5° and 30°, preferably within the range between 10° and 20°, even more preferably is 14°.

3. The screw nail (1) according to claim 1 or 2, **characterised in that** at least one knurling section (6a, 6b, 6c), in particular the second (6b) or a third (6c) knurling section, has an uneven increase along the shaft (2).

4. The screw nail (1) according to any of the preceding claims, **characterised in that** a profile of the knurling (6) is arranged distributed evenly around the circumference of the shaft (2).

5. The screw nail (1) according to any of the preceding claims, **characterized in that** the number of threads of the knurling (6) distributed around the circumference of the shaft (2) are between 3 and 30, preferable in the range between 5 and 20, more preferably 10.

6. The screw nail (1) according to any of the preceding claims, **characterised in that** a profile depth of the knurling (6) decreases towards the point (4) and comes within the range between 0.01 and 0.15 mm.

7. The screw nail (1) according to any of the preceding Claims 1 to 5, **characterised in that** on the hole formation region (5), in order to gently expand the components to be penetrated, a number of sections (5a, 5b) tapering towards the point (4) are formed, of which at least two of the sections (5a, 5b) have different degrees of tapering in relation to one another.

8. The screw nail (1) according to any of the preceding claims, **characterised in that** the hole formation region (5) is at least partially ogival in form.

9. The screw nail (1) according to any of the preceding claims, **characterised in that** the hole formation region (5) is at least partially conical or ballistic in form.

10. The screw nail (1) according to any of the preceding claims, **characterised in that** two sections (5a, 5b) formed in the hole formation region (5) are connected to one another respectively by means of an intermediate stage (7) which is in particular cylindrical.

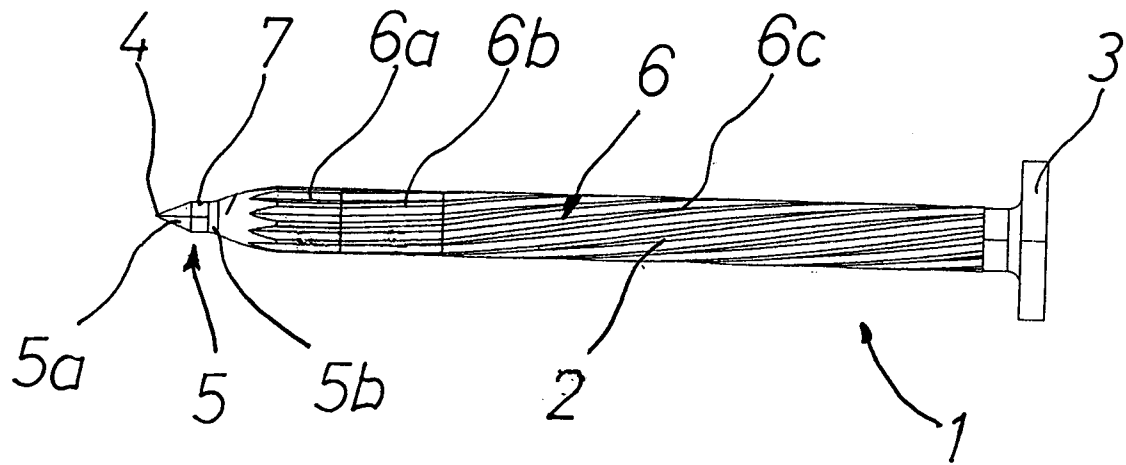

FIG. 1

INTERNATIONAL SEARCH REPORT

International application No
PCT/EP2009/008362

A. CLASSIFICATION OF SUBJECT MATTER
INV. F16B5/06
ADD.

According to International Patent Classification (IPC) or to both national classification and IPC

B. FIELDS SEARCHED

Minimum documentation searched (classification system followed by classification symbols)
F16B

Documentation searched other than minimum documentation to the extent that such documents are included in the fields searched

Electronic data base consulted during the international search (name of data base and, where practical, search terms used)

EPO-Internal

C. DOCUMENTS CONSIDERED TO BE RELEVANT

Category*	Citation of document, with indication, where appropriate, of the relevant passages	Relevant to claim No.
A	EP 0 576 034 B1 (DEUTSHER PTY LTD [AU]) 9 October 1996 (1996-10-09) column 4, line 55 - column 6, line 7 figures 1-9	1-10
A	----- WO 2007/106255 A1 (HKN INTERNATIONAL LLC [US]; GREENE KEVIN [US]; KUDLAK DON [US]) 20 September 2007 (2007-09-20) the whole document	1-10
A	----- US 2002/071741 A1 (OSWALD ROBERT C [US]) 13 June 2002 (2002-06-13) the whole document	1-10
	----- -/--	

Further documents are listed in the continuation of Box C.

See patent family annex.

* Special categories of cited documents :

- "A" document defining the general state of the art which is not considered to be of particular relevance
- "E" earlier document but published on or after the international filing date
- "L" document which may throw doubts on priority claim(s) or which is cited to establish the publication date of another citation or other special reason (as specified)
- "O" document referring to an oral disclosure, use, exhibition or other means
- "P" document published prior to the international filing date but later than the priority date claimed

- "T" later document published after the international filing date or priority date and not in conflict with the application but cited to understand the principle or theory underlying the invention
- "X" document of particular relevance; the claimed invention cannot be considered novel or cannot be considered to involve an inventive step when the document is taken alone
- "Y" document of particular relevance; the claimed invention cannot be considered to involve an inventive step when the document is combined with one or more other such documents, such combination being obvious to a person skilled in the art.
- "&" document member of the same patent family

Date of the actual completion of the international search

28 July 2010

Date of mailing of the international search report

04/08/2010

Name and mailing address of the ISA/

European Patent Office, P.B. 5818 Patentlaan 2
NL - 2280 HV Rijswijk
Tel. (+31-70) 340-2040,
Fax: (+31-70) 340-3016

Authorized officer

Huusom, Carsten

INTERNATIONAL SEARCH REPORT

International application No

PCT/EP2009/008362

C(Continuation). DOCUMENTS CONSIDERED TO BE RELEVANT

Category*	Citation of document, with indication, where appropriate, of the relevant passages	Relevant to claim No.
A	WO 2007/043985 A1 (ILLINOIS TOOL WORKS [US]; DILL MICHAEL C [US]; KOLODZIEJ NORBERT K [US]) 19 April 2007 (2007-04-19) * abstract figures 1-4	1-10
A	EP 0 164 432 B1 (WAKAI SANGYO KK [JP]) 3 February 1988 (1988-02-03) column 2, lines 9-12 column 2, lines 36-42 column 4, lines 26-38 claim 1 figures 1,4,5	1-10

INTERNATIONAL SEARCH REPORT

Information on patent family members

International application No

PCT/EP2009/008362

Patent document cited in search report	Publication date	Patent family member(s)	Publication date
EP 0576034	B1	09-10-1996	CA 2099228 A1 27-12-1993 EP 0576034 A1 29-12-1993 JP 2563069 B2 11-12-1996 JP 6213220 A 02-08-1994 US 5391029 A 21-02-1995
WO 2007106255	A1	20-09-2007	US 2007217889 A1 20-09-2007
US 2002071741	A1	13-06-2002	NONE
WO 2007043985	A1	19-04-2007	AU 2005333514 A1 08-02-2007 CA 2572604 A1 26-01-2006 EP 1812719 A1 01-08-2007
EP 0164432	B1	03-02-1988	AT 32370 T 15-02-1988 DE 3469208 D1 10-03-1988 EP 0164432 A1 18-12-1985