



US00D891777S

(12) **United States Design Patent**  
**Newton**

(10) **Patent No.:** **US D891,777 S**  
(45) **Date of Patent:** **\*\* Aug. 4, 2020**

(54) **TRANSPORT TRAY**

(71) Applicant: **William Charles Brian Newton,**  
Greensboro, NC (US)

(72) Inventor: **William Charles Brian Newton,**  
Greensboro, NC (US)

(\*\*) Term: **15 Years**

(21) Appl. No.: **29/621,341**

(22) Filed: **Oct. 6, 2017**

(51) **LOC (12) Cl.** ..... **09-04**

(52) **U.S. Cl.**  
USPC ..... **D3/304**

(58) **Field of Classification Search**

USPC ..... D3/304, 318, 319; D6/672, 675, 675.2,  
D6/682.3, 683; D7/387, 388, 391, 392.1,  
D7/396.1, 396.6, 403, 409, 511, 550.1,  
D7/553.1, 553.2, 566, 568, 601, 602, 614,  
D7/615, 629, 701, 703, 707, 708;  
D9/414, 416, 424, 425, 426, 427, 428,  
D9/430, 432, 433, 434, 435, 436, 456,  
D9/601, 602, 701, 703, 707, 708, 715,  
D9/721, 732, 736, 756, 761; D24/121,  
D24/123, 124, 227, 228

CPC B65D 71/04; B65D 21/0212; B65D 21/0224;  
B65D 1/36; B65D 71/70; B65D 75/5855;  
B65D 43/16; B65D 43/18; B65D 65/42;  
B65D 65/461; B65D 5/04; B65D 5/105;  
B65D 5/5035; B65D 5/0004; B65D  
5/4212; B65D 5/503; B65B 11/045;  
B65B 31/028; B65B 11/52; E04F 19/02;  
E05F 5/06; A47F 7/281; G04D 1/0021;  
G04D 1/0071; G04D 1/066; A47J 37/10;  
E04B 2001/7691; B32B 3/12

See application file for complete search history.

(56) **References Cited**

**U.S. PATENT DOCUMENTS**

1,717,974 A 6/1929 Heinrichs  
3,157,902 A 11/1964 Hardwick

3,757,990 A 9/1973 Buth  
D289,719 S \* 5/1987 Daenen ..... D7/392.1  
D291,526 S \* 8/1987 Heaney ..... D7/354  
5,392,917 A 2/1995 Alpern et al.  
D373,284 S \* 9/1996 Hirst ..... D7/354  
D402,850 S \* 12/1998 Davis ..... D7/550.1  
D462,231 S \* 9/2002 Kari ..... D7/354  
6,749,063 B2 6/2004 Parker  
D530,921 S \* 10/2006 Snell ..... D3/304  
D547,064 S \* 7/2007 Snell ..... D3/304  
D555,904 S \* 11/2007 Snell ..... D3/304  
D569,676 S \* 5/2008 Millsap ..... D7/354  
D583,615 S \* 12/2008 Simon ..... D7/354  
D588,396 S \* 3/2009 Millsap ..... D7/354

(Continued)

**FOREIGN PATENT DOCUMENTS**

EP 1 439 795 6/2006  
WO WO 96/07364 3/1996

(Continued)

*Primary Examiner* — Catherine S Posthauer  
(74) *Attorney, Agent, or Firm* — Tuggle Duggins P.A.;  
Blake P. Hurt

(57) **CLAIM**

The ornamental design for a transport tray, as shown and described.

**DESCRIPTION**

FIG. 1 is a top, front, right side perspective view of a transport tray showing my new design;  
FIG. 2 is a top plan view thereof;  
FIG. 3 is a left side elevational view thereof, the right side elevational view being a mirror image thereof;  
FIG. 4 is a rear elevational view thereof, the front elevational view being a mirror image thereof; and,  
FIG. 5 is a bottom plan view thereof.

**1 Claim, 5 Drawing Sheets**

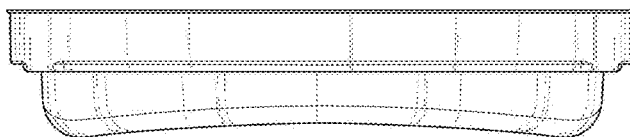
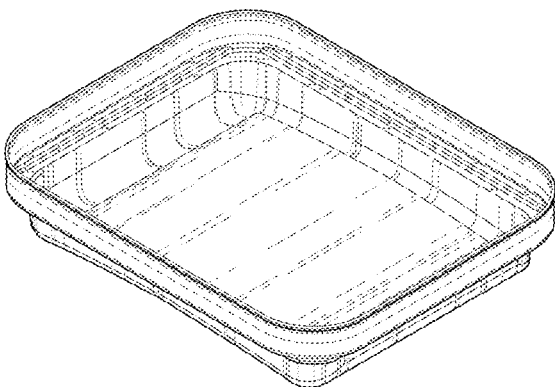

(56)

**References Cited**

## U.S. PATENT DOCUMENTS

D612,723 S \* 3/2010 Bougoulas ..... D9/435  
D653,496 S \* 2/2012 Henry ..... D7/354  
D663,570 S \* 7/2012 Sarnoff ..... D7/354  
D677,154 S \* 3/2013 Miller ..... D9/424  
D686,498 S \* 7/2013 Rego ..... D9/456  
D688,461 S \* 8/2013 Ambrefe, Jr. .... D3/304  
D708,951 S \* 7/2014 Studt ..... D9/456  
D717,597 S \* 11/2014 Henry ..... D7/363  
D731,230 S \* 6/2015 Librus ..... D7/354  
D772,058 S \* 11/2016 Urushidani ..... D7/602  
D772,059 S \* 11/2016 Urushidani ..... D7/602  
D774,349 S \* 12/2016 Zemel ..... D7/354  
D778,365 S \* 2/2017 Kott ..... D20/43  
D784,067 S \* 4/2017 Keating ..... D7/354  
D792,759 S \* 7/2017 Foster ..... D7/602  
D802,970 S \* 11/2017 Henonin ..... D6/675  
D809,848 S \* 2/2018 Mirchandani ..... D7/354  
D817,072 S \* 5/2018 Mirchandani ..... D7/354  
D820,629 S \* 6/2018 Lum ..... D7/354  
D824,115 S \* 7/2018 Couse ..... D30/119  
D829,545 S \* 10/2018 Thurin ..... D9/425  
D834,314 S \* 11/2018 Nicoline ..... D3/304  
D838,536 S \* 1/2019 Wilkinson ..... D7/354  
2009/0123333 A1 5/2009 Parker et al.  
2011/0192744 A1 8/2011 Parker et al.  
2012/0074149 A1 3/2012 Roth  
2014/0131428 A1 5/2014 Balke  
2017/0334611 A1\* 11/2017 Wu ..... A47G 19/02

## FOREIGN PATENT DOCUMENTS

WO WO 03/034936 5/2003  
WO 2015166240 11/2015

\* cited by examiner

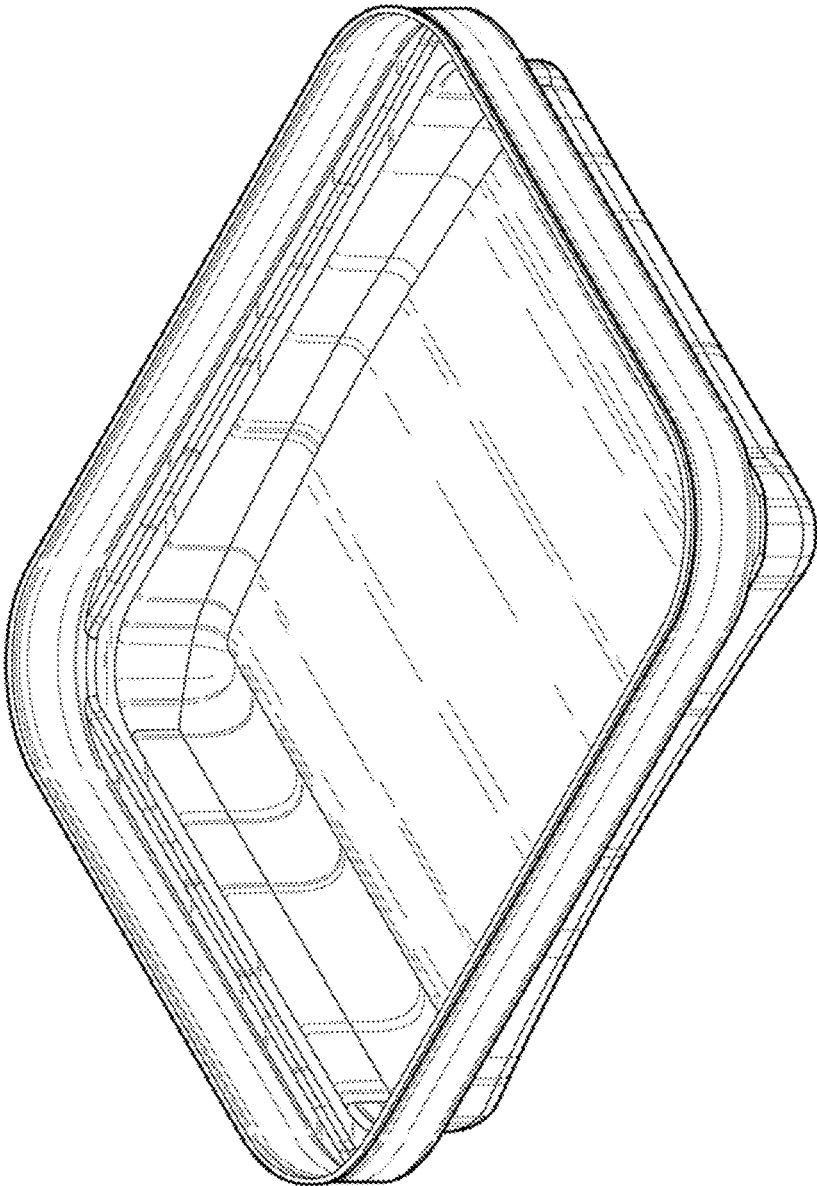

Fig. 1

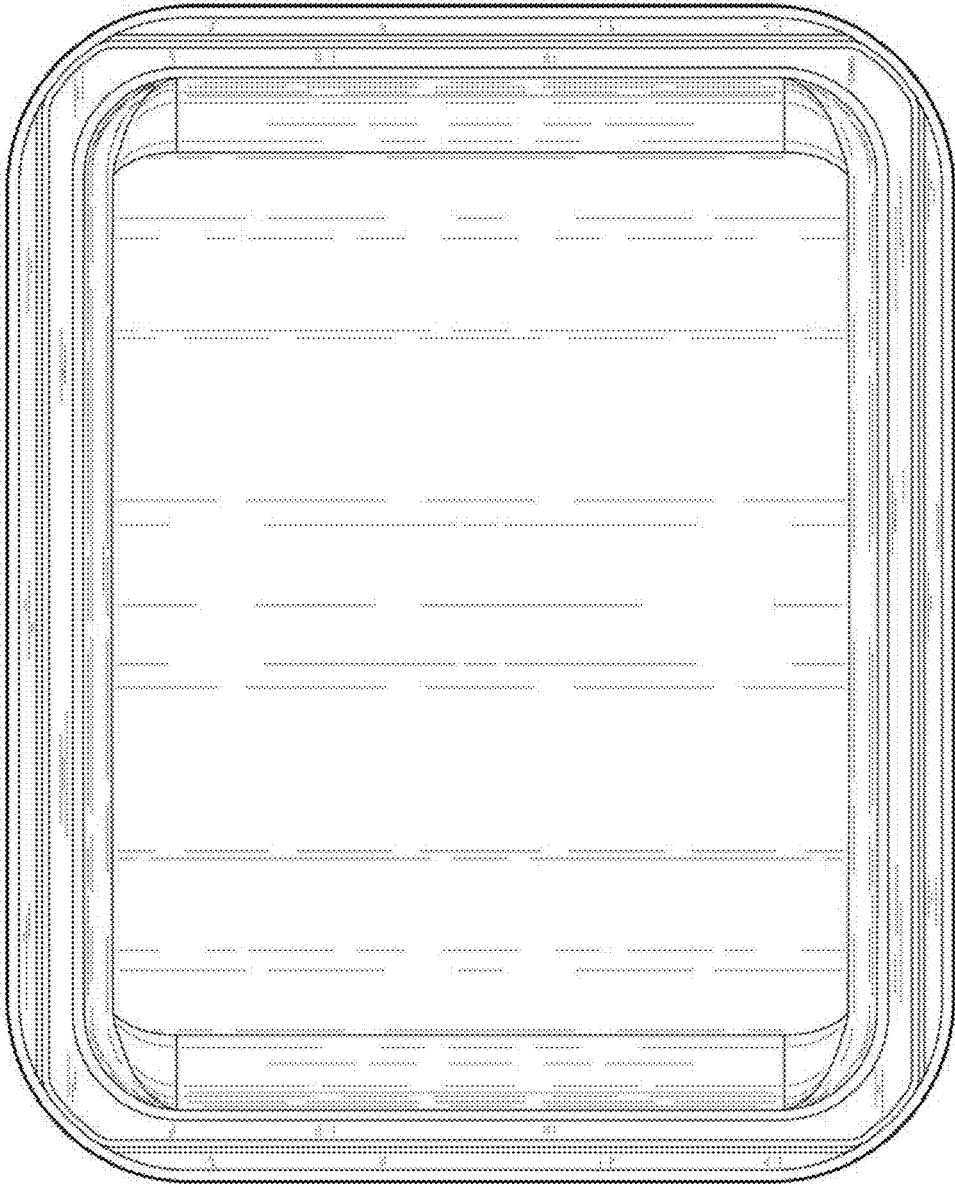

Fig. 2

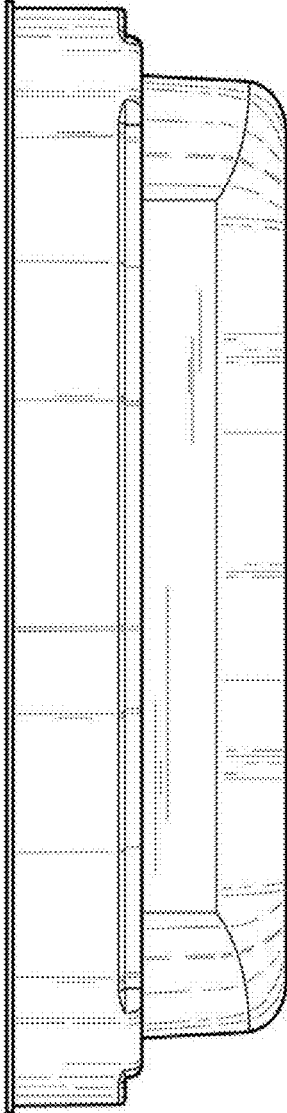

Fig. 3

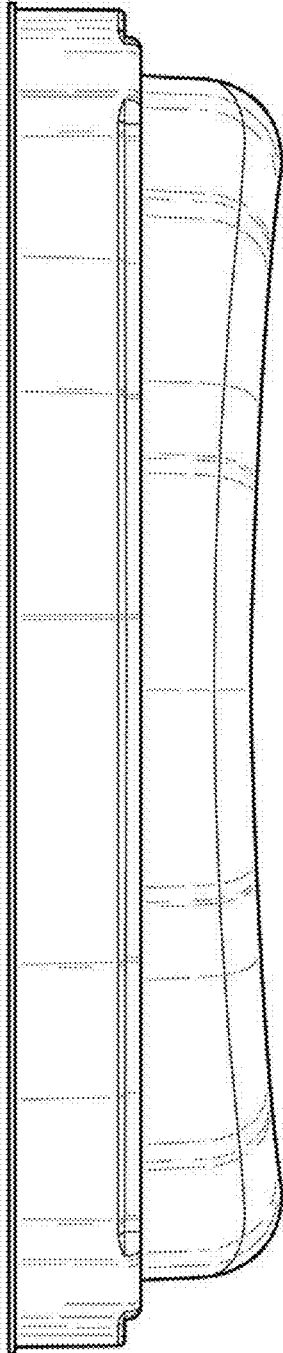

Fig. 4

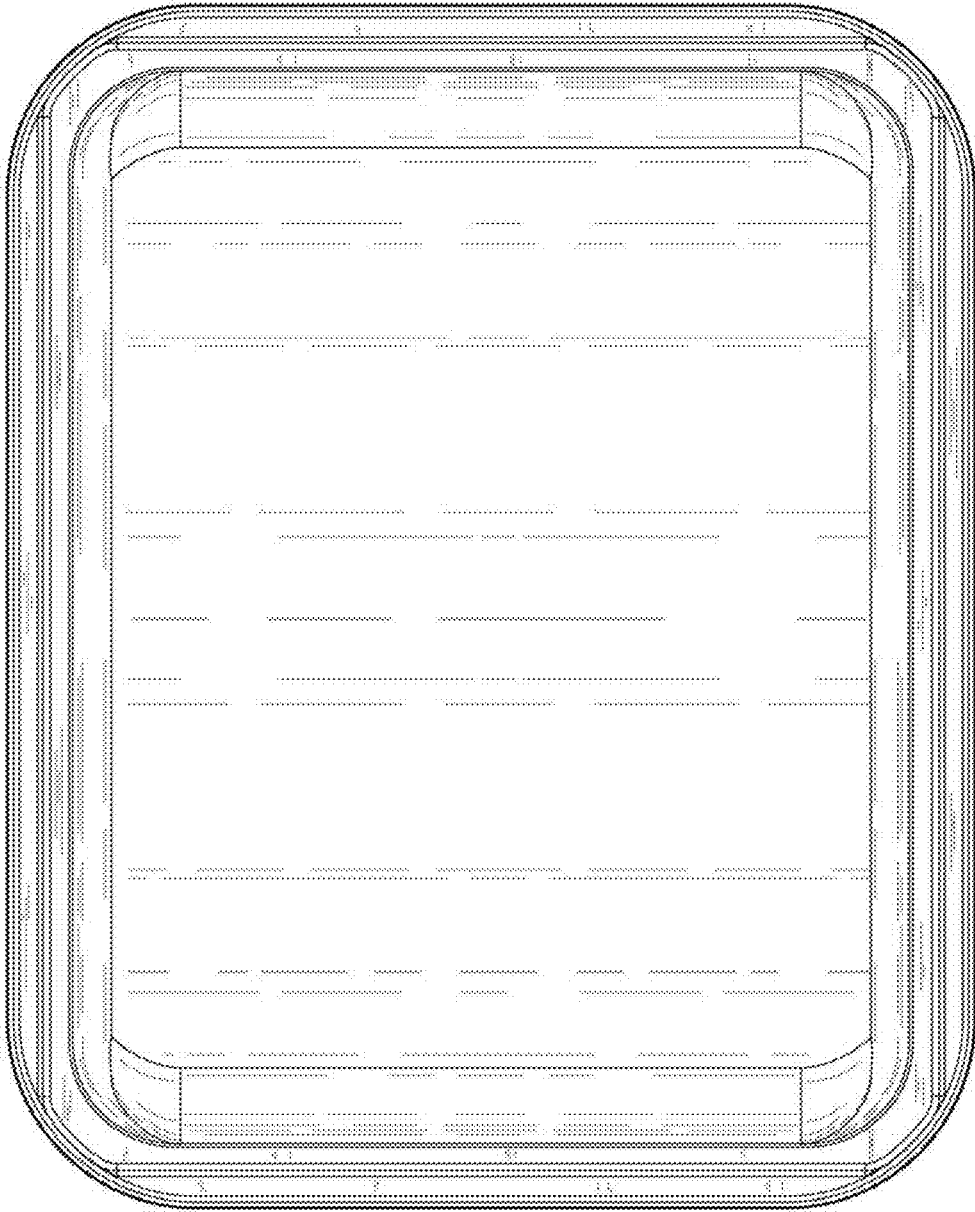

Fig. 5