

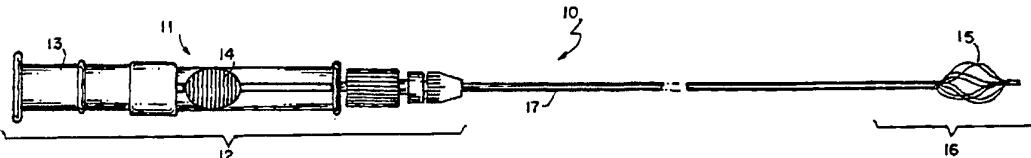

## INTERNATIONAL APPLICATION PUBLISHED UNDER THE PATENT COOPERATION TREATY (PCT)

<p>(51) International Patent Classification<sup>5</sup> : <b>A61B 8/00</b></p>	<p><b>A1</b></p>	<p>(11) International Publication Number: <b>WO 94/18888</b></p> <p>(43) International Publication Date: 1 September 1994 (01.09.94)</p>
<p>(21) International Application Number: PCT/US94/01885</p> <p>(22) International Filing Date: 15 February 1994 (15.02.94)</p> <p>(30) Priority Data: 08/019,551 19 February 1993 (19.02.93) US</p> <p>(71) Applicant: BOSTON SCIENTIFIC CORPORATION [US/US]; 480 Pleasant Street, Watertown, MA 02172 (US).</p> <p>(72) Inventors: BATES, James, S.; 2627 Banta Avenue, Bloomington, IN 47403 (US). TRIPP, Hugh, A.; 42 Leonard Street, Foxboro, MA 02035 (US).</p> <p>(74) Agent: HERBSTER, George, A.; Pearson &amp; Pearson, 12 Hurd Street, Lowell, MA 01852 (US).</p>		<p>(81) Designated States: CA, JP, European patent (AT, BE, CH, DE, DK, ES, FR, GB, GR, IE, IT, LU, MC, NL, PT, SE).</p> <p><b>Published</b> <i>With international search report.</i></p>
<p>(54) Title: SURGICAL EXTRACTOR</p>		
		
<p>(57) Abstract</p>		
<p>A surgical extractor (10) for removing calculi, such as kidney stones and gall stones, from the body. The extractor includes a handle (11) at a proximal end (12) of the extractor with a slider (14) for operation by a physician. At the distal end (16) the extractor includes a plurality of pairs of wires (15) with portions of each pair being formed along the turn of a helix. When a retaining sheath (17) is retracted, the wires, formed of a shape memory material such as stainless steel, expand such that each pair of wires closely assumes a path along a helical turn with individual wires remaining closely adjacent. This use of plural wires for each strand multiples the number of contacts with entrapped calculi and can be provided without any deleterious effect on the reliability or size of the extractor.</p>		

**FOR THE PURPOSES OF INFORMATION ONLY**

Codes used to identify States party to the PCT on the front pages of pamphlets publishing international applications under the PCT.

AT	Austria	GB	United Kingdom	MR	Mauritania
AU	Australia	GE	Georgia	MW	Malawi
BB	Barbados	GN	Guinea	NE	Niger
BE	Belgium	GR	Greece	NL	Netherlands
BF	Burkina Faso	HU	Hungary	NO	Norway
BG	Bulgaria	IE	Ireland	NZ	New Zealand
BJ	Benin	IT	Italy	PL	Poland
BR	Brazil	JP	Japan	PT	Portugal
BY	Belarus	KE	Kenya	RO	Romania
CA	Canada	KG	Kyrgystan	RU	Russian Federation
CF	Central African Republic	KP	Democratic People's Republic of Korea	SD	Sudan
CG	Congo	KR	Republic of Korea	SE	Sweden
CH	Switzerland	KZ	Kazakhstan	SI	Slovenia
CI	Côte d'Ivoire	LI	Liechtenstein	SK	Slovakia
CM	Cameroon	LK	Sri Lanka	SN	Senegal
CN	China	LU	Luxembourg	TD	Chad
CS	Czechoslovakia	LV	Latvia	TG	Togo
CZ	Czech Republic	MC	Monaco	TJ	Tajikistan
DE	Germany	MD	Republic of Moldova	TT	Trinidad and Tobago
DK	Denmark	MG	Madagascar	UA	Ukraine
ES	Spain	ML	Mali	US	United States of America
FI	Finland	MN	Mongolia	UZ	Uzbekistan
FR	France			VN	Viet Nam
GA	Gabon				

-1-

DescriptionSurgical ExtractorTechnical Field

This invention generally relates to medical instruments and more specifically to an extractor for removing an object from a body, particularly calculi that can form in the biliary and urinary systems.

Background Art

Recently developed medical instruments reduce the invasiveness and potential trauma previously associated with various medical procedures. The removal of calculi in the form of kidney stones, gallstones and the like from the body is one area where this effort is meeting with success. Various instruments now permit the removal of kidney stones and gallstones without the need for major surgery.

Some of these instruments incorporate miniaturized grasping forceps. This invention, however, is directed to an alternative set of instruments that utilize mechanical retrieval baskets as described in the following United States Letters Patent:

	4,590,938	(1986)	Segura et al
	4,611,594	(1986)	Grayhack et al
	4,625,726	(1986)	Duthoy
25	4,807,626	(1989)	McGirr

The Segura et al patent discloses a medical retrieval device that can be inserted through the working channel of an endoscope for removing stones and the like from the kidneys or the ureter or biliary duct. It includes a retrieval basket of relatively large diameter that is extendable from the distal end of a sheath and collapsible when withdrawn into the sheath. Outwardly bowed spring strips form the retrieval basket. These strips extend generally axially of the sheath and join at respective distal and proximal ends. The retrieval basket has a generally bulbous form which is relatively stiff due to

-2-

the spring strip construction and facilitates dislodgement and capture of stones.

The Grayhack et al patent discloses another retrieval basket that is useful during the removal and/or  
5 destruction of calculi. A smooth outer tubular sheath overlies and contains a stranded wire cable terminating in a protective tip at the working or distal end of the device. When the cable is extended distally, the spring wire strands at the working end of the cable expand to  
10 form a retrieval basket. The distal end of this device additionally includes an expandable distal portion for protecting surrounding tissue during withdrawal of the device and calculi.

The Duthoy patent discloses an extraction device that  
15 includes a retrieval basket formed from a plurality of wires spaced about and outwardly from an imaginary extension of the center line of a hollow cable. A filiform extends distally from the distal end of the retrieval basket to extend past a stone and to allow the  
20 basket to be threaded around and onto the calculi.

The McGirr patent discloses an extractor included a self-closing retrieval basket at the distal end of a catheter with a flexible control line for opening the basket from the proximal end of the catheter. The basket  
25 assumes a normal position wherein it is in a compact closed form. Pulling on the control line flexes the strips to open the basket. When the control line is released, the strips relax and surround the calculi or object being removed.

30 These and other surgical extractors using retrieval baskets have certain common characteristics. Each retrieval basket comprises a plurality of strands in the form of individual strips or wires substantially equiangularly spaced about the retrieval basket. In some  
35 retrieval baskets the strands are formed along substantially straight lines when the basket is in a compact form; in others, the individual strands extend along a generally helical path. Each instrument includes

-3-

a plurality of three or more strands. However, the overall size or diameter of an extractor and ancillary equipment, such as an endoscopic device, can impose upper limits on that plurality. For example, an instrument  
5 having a sheath outer diameter of 3.0 Fr can incorporate up to 6 wires each having a diameter 0.008 inches in the prior art.

Additional wires could be advantageous because increasing the number of wires increases the number of  
10 contacts between the basket and any entrapped calculi. However, the overall size limitation means that additional wires can be incorporated only by decreasing their diameters. As the individual diameters reduce, they  
15 become weaker. Moreover the individual wires are generally equiangularly spaced, so the additional wires reduce the angular spacing between adjacent wires. This can complicate the manipulation of an expanded retrieval basket onto calculi. Wires of reduced diameter can also  
20 limit any radially acting, dilating force that the wires exert against surrounding tissue when the retrieval basket expands. In some applications the retrieval basket may not fully open. This attribute can reduce the opening between adjacent wires and make it more difficult to entrap calculi. Even prior art extractors with larger  
25 single wires can fail to expand fully with the same result.

#### Disclosure of Invention

Therefore it is an object of this invention to  
30 provide a surgical extractor that increases the reliability of retaining calculi in a retrieval basket.

Another object of this invention is to provide a surgical extractor that increases the number of contact points with calculi in a retrieval basket without  
35 increasing the overall size of the instrument.

Still another object of this invention is to provide a surgical extractor that increases the number of contact points with entrapped calculi without reducing the

-4-

dilating force that can be extractor can apply to surrounding tissue.

Yet another object of this invention is to provide a surgical extractor that increases the number of contacts with entrapped calculi in an extractor and that opens fully when expanded.

Yet still another object of this invention is to provide a surgical extractor that increases the number of contacts with entrapped calculi in an extractor that is readily manufactured.

Still yet another object of this invention is to provide a surgical extractor that increases the number of contact points with entrapped calculi and requires substantially the same level of physician dexterity as required by prior art extractors having a fewer number of such contact points.

In accordance with this invention a surgical extractor for removing an object from a body includes a plurality of prestressed strands that are normally encased in a sheath and wrapped in a helical form. The displacement of the sheath from the prestressed strands enables the strands to form a basket for retrieving the object. Each of the strands comprises a plurality of individual filaments.

#### Brief Description of the Drawings

The appended claims particularly point out and distinctly claim the subject matter of this invention. The various objects, advantages and novel features of this invention will be more fully apparent from a reading of the following detailed description in conjunction with the accompanying drawings in which like reference numerals refer to like parts, and in which:

Fig. 1 is a plan view of a surgical extractor constructed in accordance with this invention with a handle at a proximal end and an expanded retrieval basket at a distal end;

-5-

Fig. 2 is an enlarged plan view of the distal end of the extractor shown in Fig. 1;

Fig. 3 is an enlarged view, partially in cross section, of the distal end of the extractor shown in Figs. 1 and 2 in a compact form;

Fig. 4 depicts the distal end of a surgical extractor incorporating a different embodiment of a retrieval basket;

Fig. 5 depicts the distal end of another surgical extractor with still a different retrieval basket;

Fig. 6 is an enlarged plan view of the handle at the proximal end of the extractor shown in Fig. 1; and

Fig. 7 is another view, partially in section, taken along lines 7-7 in Fig. 6; and

Fig. 8 is a cross sectional view taken along lines 8-8 in Fig. 7.

#### Best Mode for Carrying out the Invention

Fig. 1 depicts one embodiment of a surgical extractor constructed in accordance with this invention. The surgical extractor 10 includes a handle 11 at a proximal end 12 having a base 13 and a slider 14. A physician can grasp the base 13 in the palm in his or her hand and manipulate the slider 14 with his or her thumb. A retrieval basket 15 constructed in accordance with this invention is located at the distal end 16 of the extractor 10. A sheath 17 overlies an intermediate supporting structure between the handle 12 and the retrieval basket 15.

As shown in Fig. 1 the slider 14 is located at a proximal position. When the slider 14 advances to a distal position, that is to the right in Figs. 1 and 2, the sheath 17 advances to compact and cover the retrieval basket 15 as shown in Fig. 3. The sheath 17 typically comprises a polyimide tube or a tube of another material that exhibits the radial flexibility, axial stiffness, biocompatibility and hoop strength of a polyimide tube.

-6-

Fig. 2 depicts the distal end 16 of the surgical extractor 10 in an enlarged form and specifically discloses a substitute for a prior art four-wire retrieval basket. The retrieval basket comprises a plurality of  
5 four prestressed strands 21, 22, 23 and 24. In accordance with this invention, each of these strands comprises a plurality of individual wires. The strand 21, for example, comprises wires 21a and 21b; the strand 22, wires 22a and 22b; the strand 23, wires 23a and 23b and the  
10 strand 24, wires 24a and 24b. These wires will be made from stainless steel or some other shape memory material.

A cap 25 captures distal ends of all the wires 21a through 24b by soldering the wires in the cap 25, by swaging or by some other method. A sleeve 26 at the  
15 proximal end of the basket 25 encircles and is affixed to the wires. The cap 25 and sleeve 26 thereby define the axial extent of the retrieval basket 15 in which the individual wires are prestressed or preformed to the helical expanded shape show in Figs.1 and 2. Portions of  
20 the individual wires, such as wires 21a and 21b, extend proximally of the sleeve 26 to a connector 27 inside the sheath 17. These portions extend essentially axially between sleeve 26 and a connector 27 and within the sheath 17.

25 Consequently, the structure shown in Fig. 2 produces a retrieval basket 15 in a distal portion 30 of the wires 21a through 24b and a proximal portion 31 intermediate the sleeve 26 and connector 27. Each of the wires lies in parallel in the proximal wire portion 31, and each of the  
30 wires is independent in the distal portion 30.

Therefore, the distal end 16 of the extractor 10 remains radially flexible and, by virtue of the sheath 17, axially stiff to facilitate placement of the extractor 10. The combination of radial flexibility and axial stiffness is  
35 particularly important when the extractor 10 has the form shown in Fig. 3 with the sheath 17 advanced distally to the cap 25.



-7-

More specifically, a physician will introduce the extractor 10 with its distal end 16 in the form shown in Fig. 3. In this form the sheath 17 retains the distal wire portion 30 in its compact form and stresses the individual wires. When the extractor 10 is positioned proximate to calculi to be retrieved, the physician uses the slider 14 in Fig. 1 to retract the sheath 17 and expose the wires in the distal wire portion 30. With the constraint of sheath 17 removed, the wires return to their original shape as shown in Fig. 2 thereby to dilate surrounding tissue and to provide a structure that can be manipulated over the calculi. Once the physician has moved calculi into the retrieval basket 15 defined by the strands 21 through 24, the physician advances the sheath 17 distally and reduces the volume of the retrieval basket 15 until it contacts the entrapped calculi. Then the physician withdraws the extractor 10 with the entrapped calculi.

During manufacture of the specific embodiment of Fig. 2, eight individual wires 21a through 24b are collected together. The distal ends of the wires are soldered or swaged into the cap 25. The wires are separated into pairs corresponding to the strands 21 through 24. Each pair is then formed onto a four-part helix former. Although the wires in a strand, such as wires 21a and 21b associated with strand 21, are formed as a pair of a single strand or thread, the wires are not twisted. Consequently, each of the strands 21 through 24 will be equiangularly spaced, by approximately 90°, but individual wires, such as wires 21a and 21b of a strand, such as strand 21, will be closely angularly spaced. A typical close angular spacing will produce a separation of the wires in a set, such as wires 21a and 21b, by a distance in the range from 0 to 0.5 mm or so.

The increase in the number of wires does not reduce the openings between adjacent strands appreciably, so the effort for moving the retrieval basket 15 over calculi is about the same as required to position a prior art four-

-8-

strand basket. The sleeve 26 provides a confining force that allows the proximal portion 31 of the wires to lie in a substantially parallel entrapped relationship between the sleeve 26 and connector 27. The manufacturing process  
5 also prestressed the individual wires 21a through 25b into the helical form shown in Fig. 2.

The use of multiple wires for a given strand, such as wires 21a and 21b in strand 21, increases the number of contact points with any entrapped calculi. In Fig. 2, for  
10 example, eight wires will contact the calculi rather than four. Moreover, the close equiangular spacing of adjacent wires in a given strand also permits the wires collectively to accommodate any surface unevenness of such calculi surfaces to further increase the reliability with  
15 which the retrieval basket 15 entraps calculi.

Further, the increase in the number of wires, such as doubling the wires from four to eight in Fig. 2, occurs without increasing the overall size of the sheath 17 or reducing the strength of the retrieval basket 15. For  
20 example, it is possible to replace four individual wires having a diameter of 0.008" in a sheath 17 with an outside diameter of 3.0 Fr with eight wires having a diameter of 0.006" due to the change in packing efficiency without a concomitant reduction in the diameter. Thus, for a given  
25 material, the collective strength of the retrieval basket 15 and of the strands 21 through 24 can increase by as much as 50% over a single-filament strand of the prior art.

When the sheath 17 moves from the position shown in  
30 Fig. 3 to the position shown in Fig. 2 and releases the retrieval basket 15, the retrieval basket 15 can exert the same or a greater dilating force on surrounding tissue as produced by a corresponding prior art device with half of the wires. Thus, the reduction in the wire size and the  
35 doubling of the number of contacts with entrapped calculi occurs without affecting the overall strength and reliability of the extractor 10.

-9-

Fig. 4 depicts an alternative embodiment of a retrieval basket 15A and sheath 17A at a distal end 16A of the extractor 10A. In this particular embodiment, the retrieval basket 15A comprises three strands 41, 42 and 5 43. Each strand, again, includes a pair of wires or filaments. For example, the strand 41 includes wires 41a and 41b. A cap 25A captures the distal end of the strands 41, 42 and 43 and another sleeve connector A sleeve, corresponding to sleeve 26, defines the proximal end of 10 the retrieval basket 15A. In this particular embodiment the strands 41, 42 and 43 would be angularly spaced by about 120°.

In this particular embodiment, the sleeve connector 25A also carries a filiform 44 that extends distally from 15 the retrieval basket 15A. Such filiforms are known in the art. Fig. 4 illustrates the use of a filiform in appropriate circumstances; a filiform can be included as an element in any embodiment of this invention.

Fig. 5 depicts another embodiment of a surgical 20 extractor 10B that includes a retrieval basket 15B at a distal end 16B and a sheath 17B. In this particular embodiment the retrieval basket 15A comprises five substantially equiangularly spaced strands 51 through 55. Each strand comprises a pair of wires or filaments, such 25 as wires 51a and 51b that form strand 51, and forms a portion of a turn of a helix. An end cap 25B retains the distal ends of the wires that form the strands 51 through 55.

As previously indicated with respect to Fig 1, the 30 sheath 17 extends between the handle 11 and the distal end 16 and contains an interconnecting link that allows the slider 14 to move the sheath 17 relative to the distal end 16. This link comprises a radially flexible stainless steel cable 60 that is shown at its distal end in Figs. 2 35 and 3, and at its proximal end in Figs. 6 and 7. The sheath 17 retains the cable 60 on its axis.

Now referring to Figs. 6 through 8, the proximal end of the cable 60 attaches to a rod 61 by swaging, soldering

-10-

or other method. The rod 61 extends proximally into the handle 11.

More specifically, the handle base 13 includes a hollowed handle portion 62 with an internal boss or  
5 receptacle 63 that receives the proximal end of the rod 61. Typically the proximal end of the rod 61 will be affixed in the receptacle 63 by an adhesive, ultrasonic or other fastening technique. Consequently, the rod 61, the cable 60 and the basket 15 are fixed spatially with  
10 respect to the handle 11.

The slider 14 rides in an axially extending chamber 64 within the base 13 formed with a radially extending slot 65. The slider 14 comprises a cylindrical, elongated body 66 that has a radial passageway 67 for allowing the  
15 cylindrical body 66 to slide axially and freely in the chamber 64 with respect to the base 13 and the rod 61.

A thumb actuator 70 includes a thumb pad 71 and radial arm 72 that are molded integrally with and extend radially from the cylindrical body 66. The arm 72 extends  
20 through the slot 65 and is therefore slidable along the axis of the extractor 10 between distal and proximal positions. In this particular embodiment the base portion 11 includes radially extending bosses 73 and 74 that define the proximal and distal terminations of the slot 65  
25 respectively. The slider than moves between a proximal position, defined when the arm 72 reaches the boss 73, and a distal position defined when the arm 72 reaches the boss 74.

The distal end of the cylindrical body 66 supports a  
30 Luer-lock fitting 75. A first component or base 76 attaches to the cylindrical body 66 and includes an axially extending aperture that allows the rod 61 to pass through the fitting 75. A detachable component 77 carries the sheath 17. Consequently, as a physician moves the  
35 thumb actuator pad 71 between proximal and distal positions, the slider 14 and the sheath 17 move relative to the rod 61, the cable 60 and the retrieval basket 15 (Fig. 1). Further as the thumb pad 71 moves toward the

-11-

distal position, the distal end of the sheath 17, as shown in Figs. 2 and 3, advances over and compacts the strands 21 through 24 of the retrieval basket 15 due to the axial stiffness and hoop strength of a polyimide tube or tube of similar material.

Therefore, each embodiment disclosed in Figs. 1 through 8 provides an extractor that meets the various objects of this invention. The extractor requires essentially the degree of dexterity as would be involved with a prior art extractor. In each embodiment the use of strands having multiple, closely adjacent, independent wires formed to be closely adjacent increases the number of contact points with an entrapped calculi without requiring a concomitant increase in the size of the overlying sheath or in the difficulty placing the retrieval basket over calculi. Thus the extractor with multiple wire strands does not subject patient to any increase or trauma during its introduction into the body. Moreover, this is accomplished without affecting the strength and reliability of the retrieval basket.

This invention has been described with respect to specific embodiments constructed with specific materials. Other materials can be substituted for various components. The interconnecting structure between the retrieval basket at the distal end of the extractor and the handle can be modified. Different numbers of strands and different numbers of wires or filaments in a strand may be incorporated in an extractor. It also will be apparent that many other modifications can be made to the disclosed apparatus without departing from the invention. Therefore, it is the intent of the appended claims to cover all such variations and modifications as come within the true spirit and scope of this invention.

-12-

Claims

1. In a surgical extractor for removing an object from a body including a plurality of threads normally encased in a sheath and wrapped in a helical form  
5 whereupon displacement of a portion of the threads from the sheath enables the threads to form a basket for retrieving an object, the improvement wherein each of said threads comprises a set of a plurality of individual, spaced filaments.
- 10 2. A surgical extractor as recited in claim 1 wherein the filaments are formed of a shape memory material.
3. A surgical extractor as recited in claim 2 wherein the shape memory material is stainless steel.
- 15 4. A surgical extractor as recited in claim 3 wherein said set comprises a pair of filaments.
5. A surgical extractor as recited in claim 4 wherein  
20 said plurality of threads is in the range of 3 to 5.
6. A surgical extractor as recited in claim 5 wherein each of said filaments in a pair are untwisted.
- 25 7. A surgical extractor as recited in claim 1 wherein a at least one of said sets comprises a pair of individual filaments.
8. A surgical extractor as recited in claim 1 wherein  
30 said plurality of threads is in the range of 3 to 5.
9. A surgical extractor as recited in claim 8 wherein each said set comprises a pair of individual filaments.
- 35 10. A surgical extractor as recited in claim 9 wherein each of said filaments in a pair are untwisted.

-13-

11. A surgical extractor as recited in claim 1 wherein each of said filaments in a set are untwisted.
- 5 12. A surgical extractor as recited in claim 11 wherein each said set comprises a pair of individual filaments.
13. A surgical extractor for removing an object from a body comprising:
- 10 A. handle means extending along an axis at a proximal portion of said extractor for operating said extractor, said handle means having base means for being grasped by a physician and slider means for reciprocating along the axis
- 15 with respect to said base means,
- B. basket forming means connected to said base means for forming a basket distally of said handle means, said basket forming means including a plurality of sets of filaments being
- 20 helically wound with each set of filaments constituting a turn in a helix, and each said set of spaced filaments comprising a plurality of individual spaced filaments prestressed in a distal portion thereof for forming an enlarged
- 25 basket, and
- C. sheath means connected to said slider means and axially displaceable between first and second positions with respect to said basket forming means whereby said sheath means retains said
- 30 filaments in a compact form within said sheath means in a first position and exposes the distal portion of said basket forming means in the second position thereby to enable said prestressed filaments to form an enlarged
- 35 basket.

-14-

14. A surgical extractor as recited in claim 13 wherein the filaments are formed of a shape memory material.
15. A surgical extractor as recited in claim 14 wherein  
5 the shape memory material is stainless steel.
16. A surgical extractor as recited in claim 15 wherein each said set comprises a pair of individual filaments.
- 10 17. A surgical extractor as recited in claim 16 wherein said plurality of sets is in the range of 3 to 5.
18. A surgical extractor as recited in claim 17 wherein  
15 each of said filaments in a pair are untwisted.
19. A surgical extractor as recited in claim 13 wherein each said set comprises a pair of individual filaments.
- 20 20. A surgical extractor as recited in claim 13 wherein said plurality of sets is in the range of 3 to 5.
21. A surgical extractor as recited in claim 20 wherein  
25 each said set comprises a pair of individual filaments.
22. A surgical extractor as recited in claim 21 wherein  
30 each of said filaments in a pair are untwisted.
23. A surgical extractor as recited in claim 19 wherein each of said filaments in a pair are untwisted.
24. A surgical extractor as recited in claim 13  
35 additionally comprising radially flexible, axially stiff support means attached intermediate said handle base means and said basket forming means and lying within said sheath means wherein said filaments



-15-

- 5 additionally have a proximal portion that attaches to the distal end of said support means and said basket forming means additionally includes means at opposite ends of said distal portion for binding said filaments and limiting the axial extent of said enlarged basket.
25. A surgical extractor as recited in claim 24 wherein said extractor additionally includes a filiform extending distally of said distal portion.
- 10 26. A surgical extractor as recited in claim 24 wherein each said set comprises a pair of filaments.
27. A surgical extractor as recited in claim 26 wherein said plurality of sets is in the range of 3 to 5.
- 15 28. A surgical extractor as recited in claim 24 wherein said filaments and support means are formed of stainless steel .
29. A surgical extractor as recited in claim 28 wherein said sheath comprises a polyimide tube that overlies said support means and said plurality of filaments.
- 20 30. A surgical extractor as recited in claim 19 wherein said handle base means and said handle slider means are formed of molded plastic.
- 25 31. A surgical extractor as recited in claim 24 wherein said handle base means includes means for engaging said slider means thereby to limit the axial motion of said slider means and wherein said support means connects to said handle base means.
- 30 32. A surgical extractor as recited in claim 31 wherein said support means and said filaments are formed of

-16-

stainless steel and said sheath is formed of polyimide.

33. A surgical extractor for removing objects from a body comprising:
- 5       A. a molded plastic, partially hollowed base extending axially,
  - B. support means including a solid stainless steel radially flexible, axially stiff rod attached to said base and extending distally therefrom, a  
10       stainless steel cable extending distally from said rod and means for connecting said rod and said cable together axially,
  - C. a plurality of pairs of spaced stainless steel  
15       wires attached to the distal end of said cable and including means for defining proximal and distal portion of said wires, said wires in said distal portion being formed to conform to a helix having a greater diameter than said proximal portion and each pair being  
20       equiangularly spaced with individual wires in a pair being closely angularly spaced,
  - D. a plastic slider captured in said base for limited axial movement relative thereto between distal and proximal positions, and
  - 25       E. a polyimide sheath of a given diameter having a proximal end attached to said slider for overlying said support means and said wires, said slider, in its distal position, locating said sheath coextensively with said distal  
30       portion of said wires thereby to compact and retain said wires at substantially the given diameter and, in its proximal position, retracting said sheath to release said wires to form an enlarged retrieval basket for entrapping  
35       the object.

-17-

34. A surgical extractor as recited in claim 33 wherein said surgical extractor additionally includes a filiform extending distally of said wires for facilitating the steering of said extractor to the  
5 object.
35. A surgical extractor as recited in claim 35 wherein said plurality of pairs of stainless steel wires is in the range of three to five pairs.

1/4

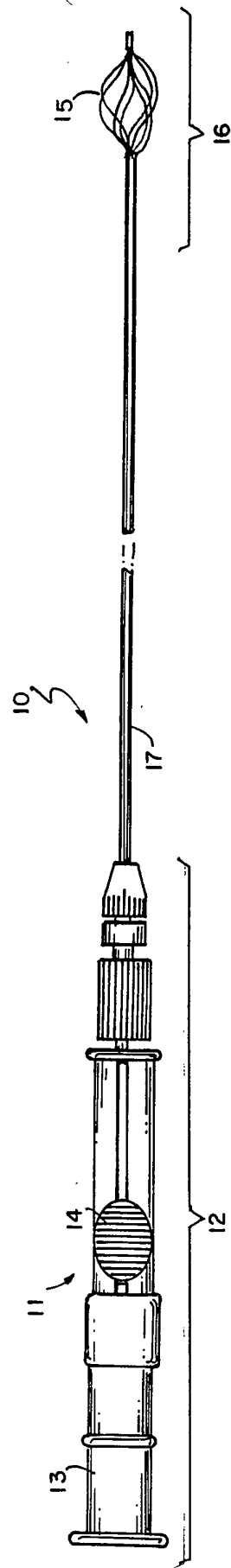

FIG. 1

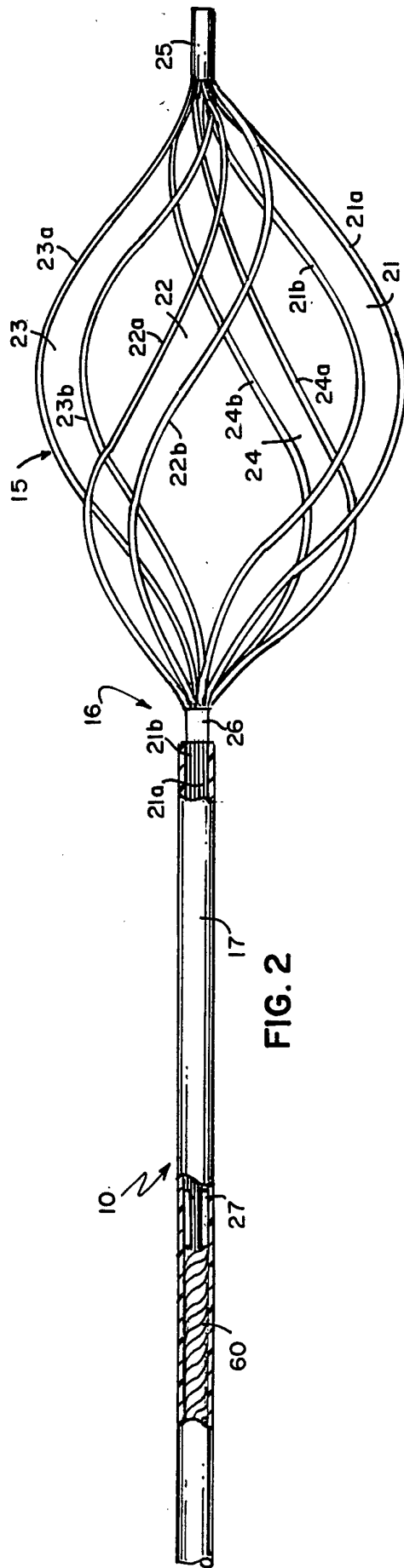

FIG. 2

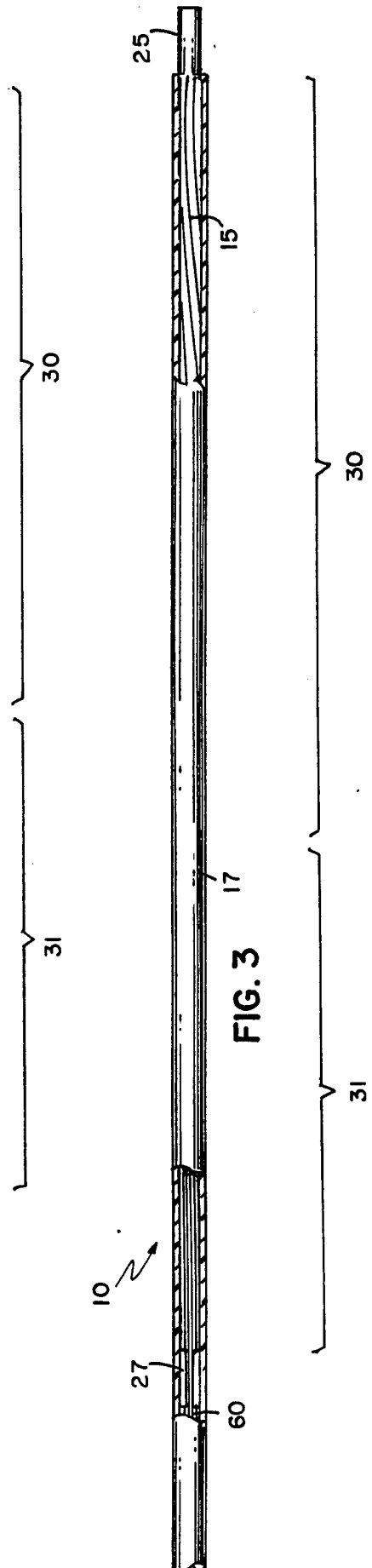

FIG. 3

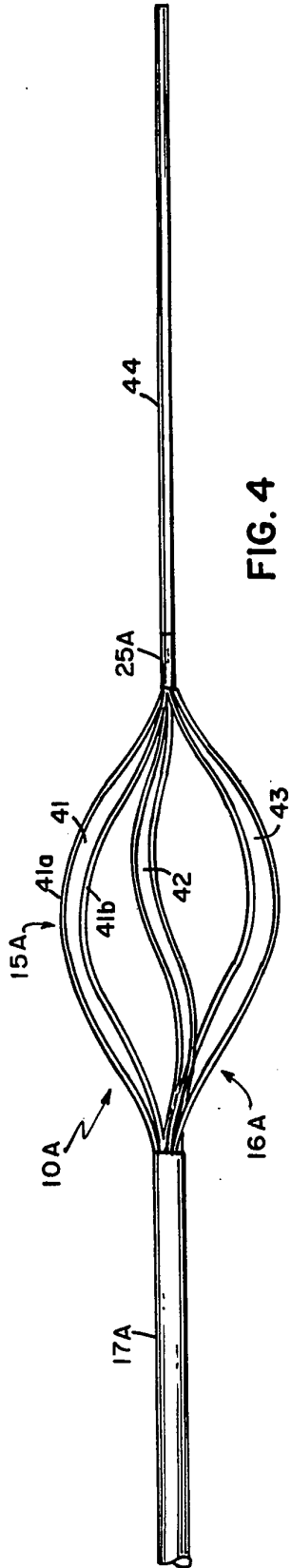

FIG. 4

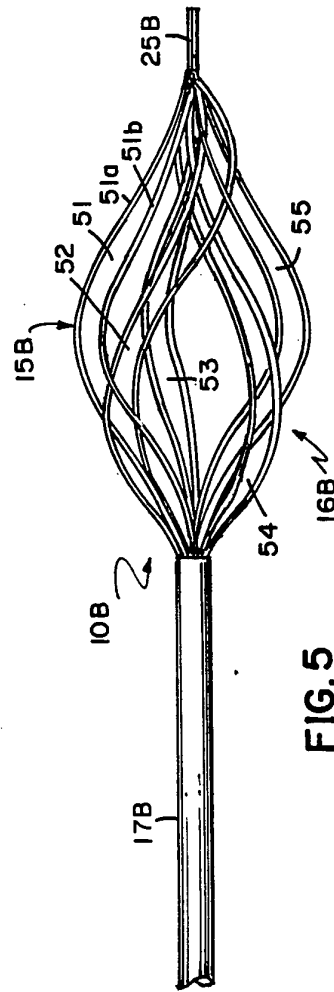
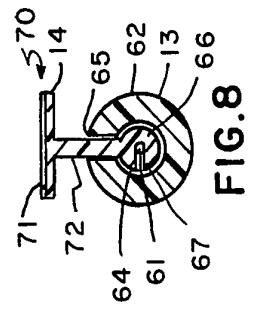
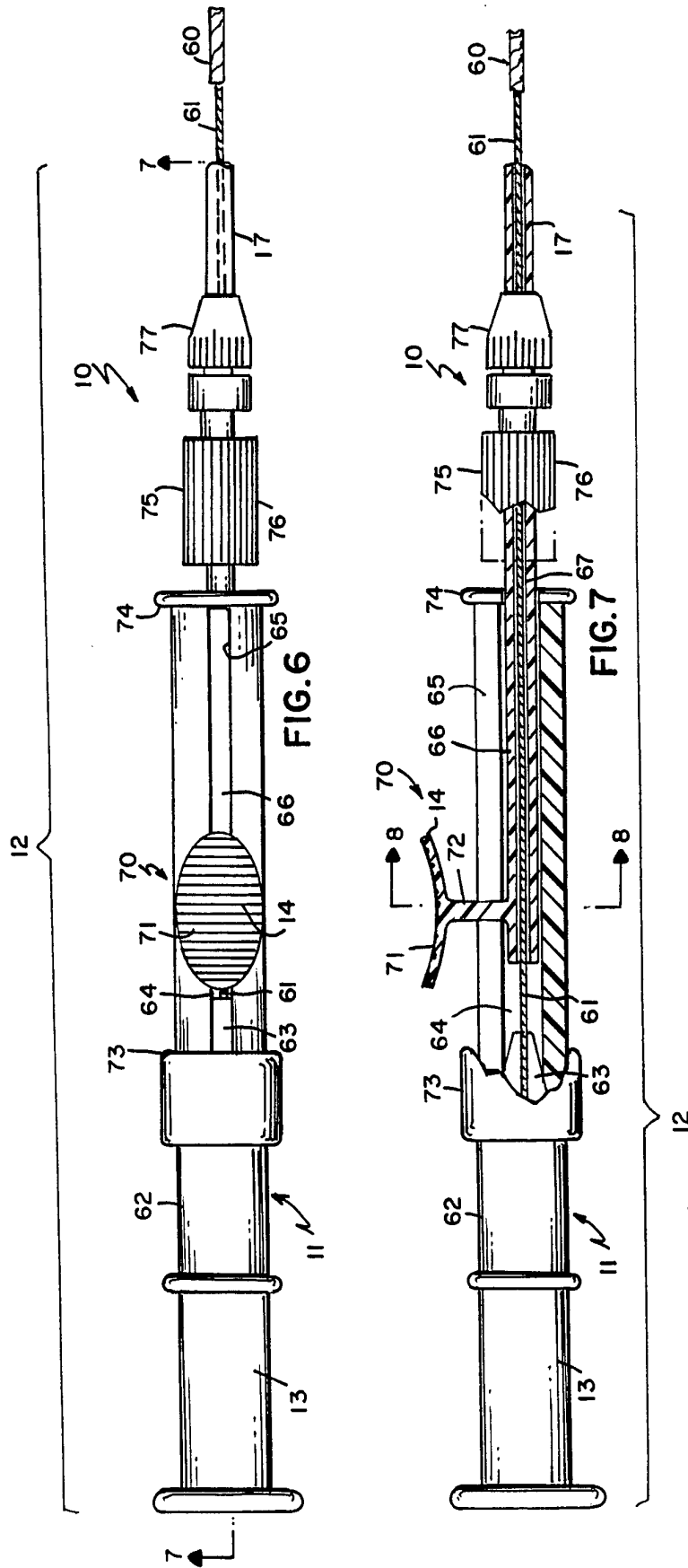

FIG. 5



INTERNATIONAL SEARCH REPORT

International application No.  
PCT/US94/01885

**A. CLASSIFICATION OF SUBJECT MATTER**

IPC(5) :A61B 8/00

US CL :606/127, 110, 113

According to International Patent Classification (IPC) or to both national classification and IPC

**B. FIELDS SEARCHED**

Minimum documentation searched (classification system followed by classification symbols)

U.S. : 606/ 1, 110, 113, 114, 127, 128

Documentation searched other than minimum documentation to the extent that such documents are included in the fields searched

Electronic data base consulted during the international search (name of data base and, where practicable, search terms used)

**C. DOCUMENTS CONSIDERED TO BE RELEVANT**

Category*	Citation of document, with indication, where appropriate, of the relevant passages	Relevant to claim No.
X ----, P Y	DT, A, 2428319 (LEVEEN) 01 February 1994. See Figs. 3, 5, and 7.	1, 2, 7, 11 - 14 , 19, 23, 24, 26,28 and 30- 31 ----- 3-6,8-10, 15- 18, 20 - 22, 25,27,29 and 32-35
Y	US, A, 4,046,150 (SCHWARTZ et al) 06 September 1977. See Figs. 1 AND 4, Col. 1 Lines 51-60, Col. 3, Line 34	3-6,8-10,15 - 18, 20 - 22, 25,27,29 and 32-35

Further documents are listed in the continuation of Box C.  See patent family annex.

* Special categories of cited documents:	"T"	later document published after the international filing date or priority date and not in conflict with the application but cited to understand the principle or theory underlying the invention
"A" document defining the general state of the art which is not considered to be part of particular relevance	"X"	document of particular relevance; the claimed invention cannot be considered novel or cannot be considered to involve an inventive step when the document is taken alone
"E" earlier document published on or after the international filing date	"Y"	document of particular relevance; the claimed invention cannot be considered to involve an inventive step when the document is combined with one or more other such documents, such combination being obvious to a person skilled in the art
"L" document which may throw doubts on priority claim(s) or which is cited to establish the publication date of another citation or other special reason (as specified)	"&"	document member of the same patent family
"O" document referring to an oral disclosure, use, exhibition or other means		
"P" document published prior to the international filing date but later than the priority date claimed		

Date of the actual completion of the international search 28 MARCH 1994	Date of mailing of the international search report 21 APR 1994
--	---

Name and mailing address of the ISA/US Commissioner of Patents and Trademarks Box PCT Washington, D.C. 20231 Facsimile No. (703) 305-3590	Authorized officer <i>Allen W. O'Keefe</i> for GLENN KEITH DAWSON Telephone No. (703) 308-0858
---	---