



(12) **DEMANDE DE BREVET CANADIEN
CANADIAN PATENT APPLICATION**

(13) **A1**

(86) Date de dépôt PCT/PCT Filing Date: 2016/09/30
(87) Date publication PCT/PCT Publication Date: 2017/04/06
(85) Entrée phase nationale/National Entry: 2018/03/29
(86) N° demande PCT/PCT Application No.: CA 2016/051143
(87) N° publication PCT/PCT Publication No.: 2017/054088
(30) Priorité/Priority: 2015/09/30 (US62/234,711)

(51) Cl.Int./Int.Cl. *H02J 7/00* (2006.01),
B65D 85/88 (2006.01), *H05K 5/00* (2006.01)
(71) Demandeur/Applicant:
EISENBRUK, ROBERT, CA
(72) Inventeur/Inventor:
EISENBRUK, ROBERT, CA
(74) Agent: BROUILLETTE LEGAL INC.

(54) Titre : DISPOSITIF ET PROCEDE DE CHARGE, DE DISTRIBUTION ET DE STOCKAGE DE BATTERIE
(54) Title: BATTERY CHARGING, DISPENSING AND STORING DEVICE AND METHOD

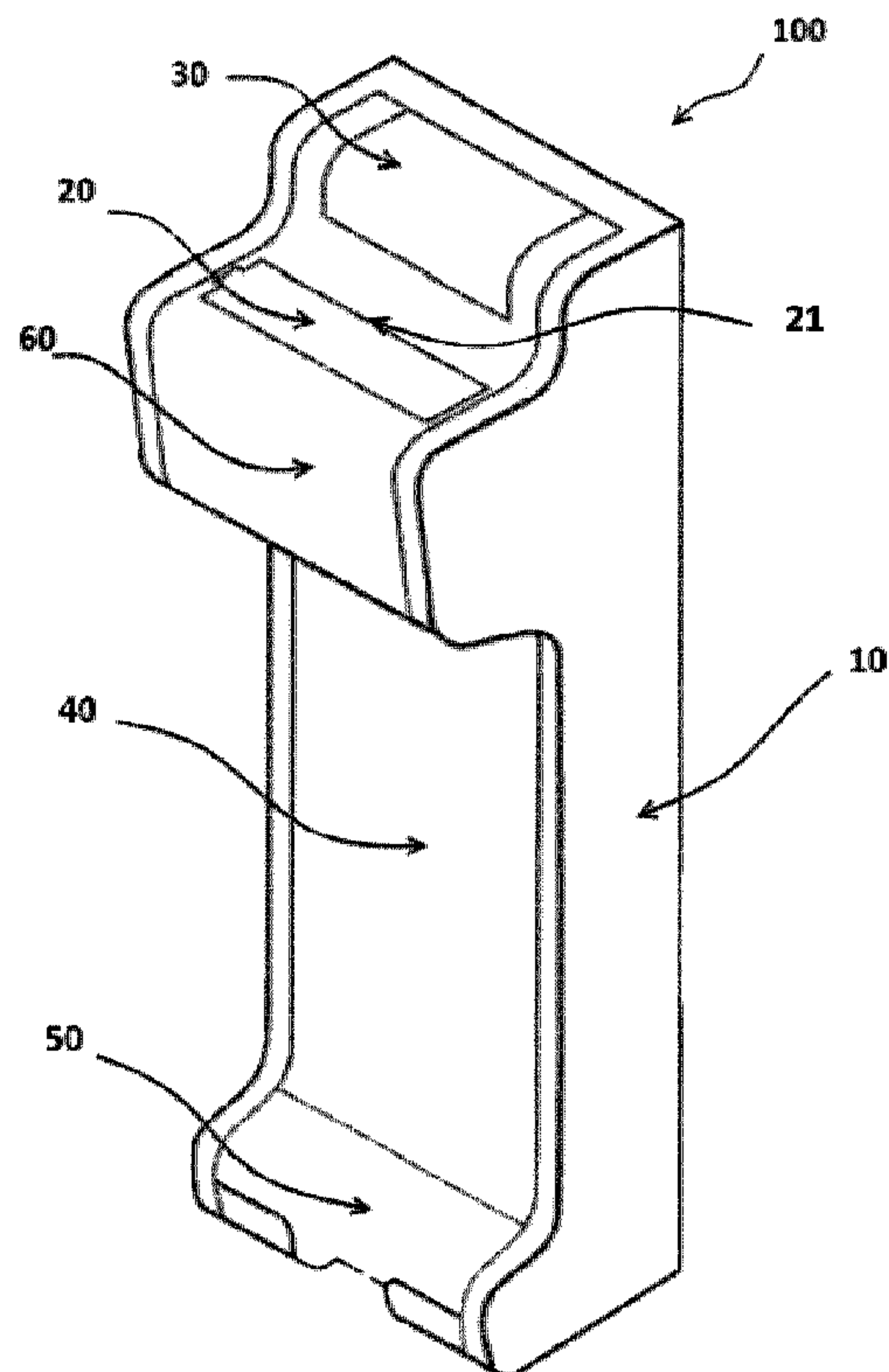

FIG. 1

(57) Abrégé/Abstract:

A battery charger adapted to simultaneously store, charge and dispense batteries. The battery charger is in an elongated form having a reservoir to store the battery in an upper portion and provides a mean to push the batteries from the reservoir toward charging station which are vertically aligned in a charging compartment connected to the reservoir by a passageway. When the push means is activated, a battery from the storing compartment is pushed in an uppermost charging station, pushing any battery present in the said uppermost charging station. When all charging stations contain a battery, the battery from the lowermost charging station is expelled or ejected from the said lowermost charging station.

(12) INTERNATIONAL APPLICATION PUBLISHED UNDER THE PATENT COOPERATION TREATY (PCT)

(19) World Intellectual Property
Organization
International Bureau(10) International Publication Number
WO 2017/054088 A1(43) International Publication Date
6 April 2017 (06.04.2017)

- (51) **International Patent Classification:**
H02J 7/00 (2006.01) *H05K 5/00* (2006.01)
B65D 85/88 (2006.01)
- (21) **International Application Number:**
 PCT/CA2016/051143
- (22) **International Filing Date:**
 30 September 2016 (30.09.2016)
- (25) **Filing Language:** English
- (26) **Publication Language:** English
- (30) **Priority Data:**
 62/234,711 30 September 2015 (30.09.2015) US
- (72) **Inventor; and**
- (71) **Applicant :** EISENBRUK, Robert [CA/CA]; 2910
 Ontario Est, Montréal, Québec H2K 0A8 (CA).
- (74) **Agent:** BROUILLETTE LEGAL INC.; 1050 Côte du
 Beaver Hall, bureau 1500, Montréal, Québec H2Z 0A5
 (CA).

(81) **Designated States** (*unless otherwise indicated, for every kind of national protection available*): AE, AG, AL, AM, AO, AT, AU, AZ, BA, BB, BG, BH, BN, BR, BW, BY, BZ, CA, CH, CL, CN, CO, CR, CU, CZ, DE, DJ, DK, DM, DO, DZ, EC, EE, EG, ES, FI, GB, GD, GE, GH, GM, GT, HN, HR, HU, ID, IL, IN, IR, IS, JP, KE, KG, KN, KP, KR, KW, KZ, LA, LC, LK, LR, LS, LU, LY, MA, MD, ME, MG, MK, MN, MW, MX, MY, MZ, NA, NG, NI, NO, NZ, OM, PA, PE, PG, PH, PL, PT, QA, RO, RS, RU, RW, SA, SC, SD, SE, SG, SK, SL, SM, ST, SV, SY, TH, TJ, TM, TN, TR, TT, TZ, UA, UG, US, UZ, VC, VN, ZA, ZM, ZW.

(84) **Designated States** (*unless otherwise indicated, for every kind of regional protection available*): ARIPO (BW, GH, GM, KE, LR, LS, MW, MZ, NA, RW, SD, SL, ST, SZ, TZ, UG, ZM, ZW), Eurasian (AM, AZ, BY, KG, KZ, RU, TJ, TM), European (AL, AT, BE, BG, CH, CY, CZ, DE, DK, EE, ES, FI, FR, GB, GR, HR, HU, IE, IS, IT, LT, LU, LV, MC, MK, MT, NL, NO, PL, PT, RO, RS, SE, SI, SK, SM, TR), OAPI (BF, BJ, CF, CG, CI, CM, GA, GN, GQ, GW, KM, ML, MR, NE, SN, TD, TG).

[Continued on next page]

(54) **Title:** BATTERY CHARGING, DISPENSING AND STORING DEVICE AND METHOD

FIG. 1

(57) **Abstract:** A battery charger adapted to simultaneously store, charge and dispense batteries. The battery charger is in an elongated form having a reservoir to store the battery in an upper portion and provides a mean to push the batteries from the reservoir toward charging station which are vertically aligned in a charging compartment connected to the reservoir by a passage-way. When the push means is activated, a battery from the storing compartment is pushed in an uppermost charging station, pushing any battery present in the said uppermost charging station. When all charging stations contain a battery, the battery from the lowermost charging station is expelled or ejected from the said lowermost charging station.

WO 2017/054088 A1 

Published:

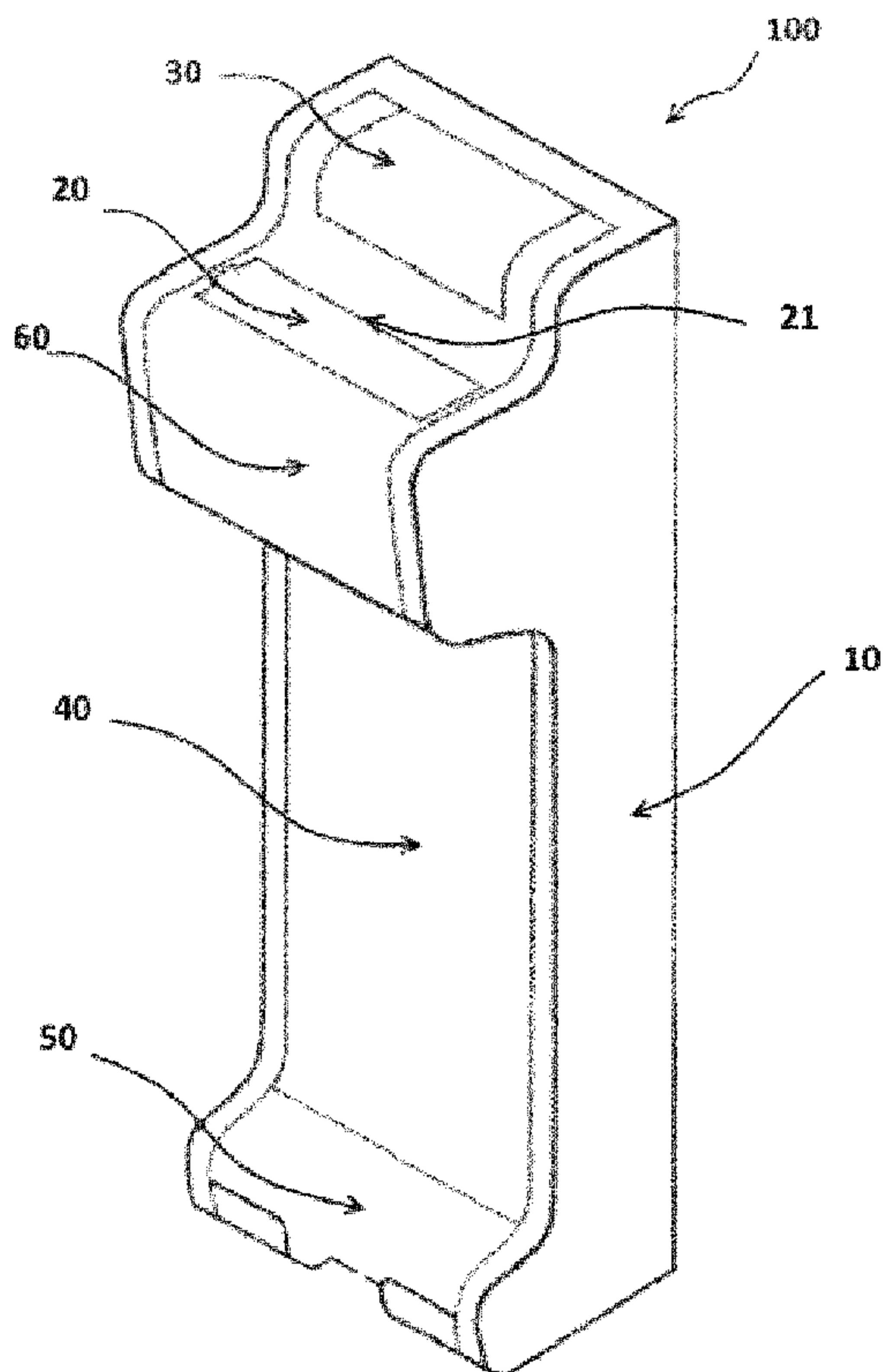
— *with international search report (Art. 21(3))*

BATTERY CHARGING, DISPENSING AND STORING DEVICE AND METHOD**Cross-Reference to Related Applications**

[0001] The present patent application claims the benefits of priority of U.S Patent Application
5 No. 62/234,711, entitled "Battery Charging Dispensing and Storing Device and Method" and
filed at the United States Patent and Trademark Office on September 30, 2015, the content of
which is included by reference.

Field of the Invention

[0002] The present invention generally relates to a battery charger for simultaneously
10 charging a multiplicity of any round format of battery cells. More particularly, the present
invention is adapted to store depleted batteries received in one way in and to dispense charged
ones.

Background of the Invention

[0003] Nowadays, many devices use a plurality of AA and AAA batteries. Typically, non-
15 rechargeable batteries are used as such batteries are fully charged and ready to be used.
However, non-rechargeable are generally used once and in many application only last one day
or one session with the device. Rechargeable batteries are not used as they bring much
inconvenient and hassles as the batteries must be rotated and charged in conventional battery
chargers. This process generally comprises removing the charged batteries from the charger
20 and replacing the said batteries with depleted one. Also, when many batteries are needed,
many electrical outlets are used as chargers are typically configured to charge up to four
batteries.

[0004] Conventionally, multi-cell charging devices, such as the battery charger disclosed in
U.S. Pat. No. 3,171,568, have been proposed to dispose and charge batteries in row. Patent
25 '568 discloses that the introduction of a depleted battery into the row at one side,
automatically lead to the expenditure of a charged battery from the other side. Such charger
doesn't allow storing of spent batteries without being charged which means a less efficient
process of consuming energy.

[0005] A general prior art solution is to insert batteries into a charger using an horizontal feed
30 without any restriction on the position or the introducing direction of the battery. Typically,

such solution requires complex electronic circuitry to ensure that each battery is charging independently of its polarity.

[0006] Despite the previous use of different systems placed at the bottom of chargers to hold batteries and prevent them from falling out of the main body, there is still a need to improve the process of charging multiple batteries and to rotate the batteries in the charger during all the process.

Summary of the Invention

[0007] The aforesaid and other objectives of the present invention are realized by generally providing a device allowing automatic rotation of the batteries when a depleted is inserted in a battery reservoir of the charging device. Such reservoir allowing to increase the number depleted batteries stored in the charging device.

[0008] The features of the present invention which are believed to be novel are set forth with particularity in the appended claims.

[0009] In one aspect of the invention, a battery charger adapted to simultaneously store and charge batteries is provided. The charger comprises an upstanding housing, the housing comprising an aperture adapted to receive batteries, a battery storing compartment in communication with the aperture, a charging compartment comprising a plurality of charging stations, the charging stations being side by side and being configured to provide current to a battery within the charging station, a guiding wall adapted to guide one or more batteries present in the charging stations to slide down along the charging compartment and a resilient member adapted to displace at least one battery present in the battery storing compartment to the charger compartment and to displace any battery present in the charger compartment to the next charging station and/or to the receiving portion. Each charging station is configured to provide a resilient force sufficient to hold a battery present in the charging station during the charging process and configured to release the battery when a battery present in the battery storing compartment is pushed toward an uppermost charging station by the resilient member.

[0010] The charging device may further comprise charging terminals adapted to provide current to the batteries and each charging station is configured to reinforce holding of batteries. The charging terminal may be made of conductive material and may be configured

to provide a resilient force sufficient to hold batteries during the charging process but adapted to release the battery when a battery is pushed by the resilient

[0011] In another aspect of the invention, the storing compartment may comprise an upper portion and a lower portion, the upper portion being adapted to store a plurality of batteries
5 and the lower portion being configured to receive only one battery.

[0012] In yet another aspect of the invention, the resilient member may comprise a handle attached to a spring, the housing being configured to receive the handle and to limit the vertical movement of the handle, the handle comprising a bottom portion adapted to push a
10 battering present in the storing compartment. The resilient member may further comprise a protrusion adapted to be received by guide rails of the housing.

[0013] In a further aspect of the invention, the housing may comprise a back wall, the back wall comprising a holding member in between two charging stations, the holding member being adapted to hold a battery within the charging station and to displace the battery toward the guiding wall when a downward force is apply on the said battery.

[0014] In another aspect of the invention, the charger may further comprise a communication
15 mean adapted to communicate with a network and a controller adapted to send status of the charging process to client device in communication with the charger. The guiding wall may further comprise an aperture adapted to access the charging stations.

[0015] The present invention also provided a method for storing, charging and dispensing
20 batteries. The method comprises inserting a battery to be charged in an aperture of a charging device, the aperture being in communication with a storing compartment, activating a resilient member of the charger to displace a battery present in the storing compartment to an upper most charging station of a charging compartment through a passage portion in-between the storing compartment and the charging compartment, the charging compartment comprising a
25 plurality of charging stations being vertically aligned and providing a resilient force sufficient to hold a battery present in the charging station during the charging process and configured to release the battery when a battery present in the battery storing compartment is pushed by the resilient member, the resilient member being configured to provide a force sufficient to release all batteries present in the charging stations, and repeating step b) until a battery
30 present in a lowermost charging station is ejected from the lowermost charging station.

[0016] In yet another aspect of the invention, the resilient member may comprise a handle, the activating of the resilient member is done by downwardly pushing the handle.

[0017] In a further aspect of the invention, the battery present in the lowermost charging station is ejected in a battery charger under the lowermost charging station.

- 5 [0018] The aperture for inserting batteries may be shaped as the type of battery to be inserted, the method further comprising aligning the battery with the shape of the aperture.

[0019] The method may also further comprise communicating status of the charging device to at least one device in communication with the charging device.

10 **Brief Description of the Drawings**

[0020] The above and other objects, features and advantages of the invention will become more readily apparent from the following description, reference being made to the accompanying drawings in which:

- 15 [0021] Figure 1 is a perspective view of a battery charger device in accordance with the principles of the present invention.

[0022] Figure 2 is a perspective view of the inner portion of the battery charger device of Figure 1.

[0023] Figure 3 is a perspective schematic view of an inner portion of the housing of the battery charger device in accordance with the principles of the present invention.

- 20 [0024] Figure 4 is a perspective schematic inner view of the slider/feeder of the battery charger device of Figure 1.

Detailed Description of the Preferred Embodiment

- 25 [0025] A novel battery charging, dispensing and storing device and method will be described hereinafter. Although the invention is described in terms of specific illustrative embodiment(s), it is to be understood that the embodiment(s) described herein are by way of example only and that the scope of the invention is not intended to be limited thereby.

[0026] Now referring to Figure 1, a preferred embodiment of a battery charging, dispensing and storing device 100 is illustrated as perspective view. The charging device 100 comprises a

housing 10 adapted to receive a plurality of batteries, an aperture adapted to receive one or more batteries 20, a mean adapted to push/pull discharged batteries within a charging compartment 40 and/or to eject charged batteries from the charging compartment 40 and a receiving portion 50 adapted to receive ejected batteries,

5 [0027] In a preferred embodiment, the housing 10 has an upstanding elongated shape, preferably a general rectangular form.

[0028] The housing 10 comprises a mean or mechanism adapted to push/pull discharged batteries within a charging compartment 40 and/or to eject charged batteries from the charging compartment 40 from an aperture 20. In a preferred embodiment, the mean for
10 pushing batteries is a slider/feeder 30 used for pushing batteries down, generally one by one. In such an embodiment, the slider/feeder 30 is located higher than the charging compartment 40. Understandably, in other embodiment, the slider/feeder 30 could be adapted to pull the batteries inserted in an aperture 20.

[0029] Now referring to Figure 4, the mean to push discharged batteries 30 allows movement
15 limited by a certain distance L allowing only a predetermined number of batteries to come out the receiving portion or bottom shoot 50. In a preferred embodiment, the said movement of the slider 30 is guided by rails 31. A resilient member 32, such as but not limited to a spring, is located on the bottom portion of the slider 30. The resilient member 32 is adapted to allow the slider 30 to return to the standby position.

20 [0030] Referring back to Figure 1, the housing 10 comprise a discharged batteries reservoir or tank 60 and a wall 41 typically located at the front of the housing. In a preferred embodiment, with the reservoir 60 is formed by a forward offset of an upper portion of the housing 10.

[0031] Still referring to Figure 1, in a preferred embodiment, the top of the tank 60 comprises the aperture 20 adapted to receive discharged batteries. In another embodiment, a door 21,
25 such as a trap door, may cover the aperture to limit dust or other elements which could within the housing 10. In a further embodiment, the aperture 20 may be shaped as the type of battery to be inserted. As such, the shaped aperture 20 allows batteries to be inserted in one only direction allowing each terminal of the batteries to be correctly aligned with the matching terminals of the charger. In embodiments having a trap door, the door 21 may comprise a
30 resilient member, such as a spring 21 adapted to control the return the trap door after a battery is inserted within the aperture or the filling shoot 20.

[0032] In a preferred embodiment, the guiding wall 40 is adapted to guide the batteries to slide down along the charging compartment 40. In some embodiments, the guiding wall 40 may be made of transparent material for easier visual inspection. Typically, the bottom end 42 of the guiding wall is located just above the battery receiving portion or battery catcher 50.

5 [0033] In another embodiment, the guiding wall may comprise an aperture allowing access to manually push the batteries of the charging compartment 40. In such an embodiment, the aperture may be used when all the batteries within the charging compartment 40 must be ejected (ex: for maintenance of the device or in the event of a defective battery).

[0034] The battery catcher 50 is adapted to receive the charged one or more charged batteries
10 the device 100. The one or more charged batteries may be dispensed each time the user press the slider/feeder 30. In a preferred embodiment, the battery catcher 50 is adapted to hold up to two charged batteries. Understandably, in other embodiments, the battery catcher 50 may be configured to hold any number of charged batteries. For instance, the volume and the shape of the battery catcher 50 may be increased to receive more batteries. Typically, the catcher 50
15 comprises an open slot 51 for easy access for the user. In a preferred embodiment, the open slot is typically located on the top portion of the battery catcher 50.

[0035] Now referring to Figures 2 and 3, the inner portion or charging compartment 40 of the charging device 100 is shown. The charging compartment 40 comprises charging stations 13
20 for batteries. Each station 13 comprises a charging terminal 11 matching the terminal 16 of the charging battery 15. Each station 13 is typically shaped to match the type of the battery to be charged. As an example, the charging device 10 shown in Figure 2 comprises stations 13 adapted to receive AA or AAA type batteries. In other embodiments, the station 13 may be shaped to receive C or D type batteries or even 9-volt type batteries. It should be understood that the present invention is not limited to any particular shape of batteries.

25 [0036] Understandably, any type of charging system may be used in a station 13 without departing from the principles of the present disclosure. As a example, typical chargers providing constant current or smart chargers automatically stopping when batteries are charged may be used.

[0037] .Each station 13 comprises at least two connectors or terminals 11 adapted to provide
30 current/voltage to the batteries to be charged 15. Each connector 11 is made of conductive material and is configured to provide a resilient force sufficient to hold batteries during the

charging process but adapted to release the battery when a discharged battery is pushed by the slider 30 on battery to be charged. Between each two successive stations 13, a strip 12, typically made of metal, helps the retainers 11 to keep batteries in place.

[0038] In a preferred embodiment, the connector 11 are metal retainers 11.

- 5 [0039] In some embodiments, the charging device 100 may further comprise one or more indicator lights 14 adapted to display the state of the charging process. Understandably, each station 13 may comprise an indicator light 14 to show the charging status of each battery being charged.

[0040] In yet other embodiments, the charging device 100 may be connected to a network
10 through a communication mean, such as a network adapter, a wireless network adapter or a mobile adapter. In such an embodiment, the charging device would comprise a controller unit, such as CPU and a memory unit, configured to communicate the state of the charging process and/or the state of charging of each charging station 13 to a client device, such as a mobile device, a computer, a tablet, etc, using the communication mean. The controller unit may be
15 further configured or programmed to allow a client device to control the charging device upon reception of a request comprising the command to be executed. As an example, the command may comprise suspending, stopping or starting the charging process. A command might further comprise requesting the status of the charging process and other statistic of previous charges.

- 20 [0041] In other embodiments, the charging compartment 40 could also be adapted to be replaceable with another similar charging compartment 40 adapted to charge another type of batteries. As an example, the charging device 100 may comprise two charging compartment 40, one for charging AA batteries and the other for charging C batteries. In such an example, the charging compartment 40 for AA batteries would comprise more stations than the
25 charging compartment 40 for C batteries as the AA batteries are substantially smaller than the C batteries. In such embodiments, the charging compartments 40 may comprise terminal or sockets (not shown) to quickly mount the charging compartment 40 to the charging device 100.

[0042] In a preferred embodiment, once a battery is inserted into the storing compartment 60,
30 through the aperture 20, the slider 30 may be activated by downwardly pushing the handle. The activation of the slider 30 place a bottom portion of the slider in contact with a battery in

the storing compartment 60. The movement of the slider 30 pushes the said battery down from the storing compartment 60 into the most upper charging station 13 of the charging compartment 40. As the movement of the slider is limited, the movement of the battery shall not move more than the height of one charging station. The retainers 11 and optionally the strip 12 limits or stops the movement of the battery to allow maintaining said battery in the charging station 13. When a second battery is present in the storing compartment 60, the slider 30 exerts a force sufficient to guide the said second battery in a passageway above the upper most charging station 13 of the charging compartment 40. When the slider 30 is activated a second time, the second battery is moved towards the uppermost charging station 13, thus pushing on the first battery present in the uppermost charging station 13 toward the next charging station 13. The movement of the first battery is guided by the guiding wall 41 to the next charging station 13. The said procedure may be repeated until all charging stations 13 contain batteries. When a battery is present in a lowermost charging station, the force exerted by the slider 30, induces the ejection of the battery from the said lowermost charging station. In a preferred embodiment, the battery catcher 50 receives the charged battery.

[0043] In embodiments where the aperture 20 is shaped as the type of battery to be inserted, the battery must be aligned to correspond with the shape of the aperture prior to inserting the said battery through the aperture within the storing compartment.

[0044] While illustrative and presently preferred embodiment(s) of the invention have been described in detail hereinabove, it is to be understood that the inventive concepts may be otherwise variously embodied and employed and that the appended claims are intended to be construed to include such variations except insofar as limited by the prior art.

Claims

What is claimed is:

1. A battery charger adapted to simultaneously store and charge batteries, the charger comprising:
 - 5 – an upstanding housing, the housing comprising an aperture adapted to receive batteries;
 - a battery storing compartment in communication with the aperture;
 - a charging compartment comprising a plurality of charging stations, the charging stations being side by side and being configured to provide current to a battery
10 within the charging station;
 - a guiding wall adapted to guide one or more batteries present in the charging stations to slide down along the charging compartment;
 - a resilient member adapted to displace at least one battery present in the battery storing compartment to the charger compartment and to displace any battery
15 present in the charger compartment to the next charging station and/or to the receiving portion.

wherein each charging station is configured to provide a resilient force sufficient to hold a battery present in the charging station during the charging process and configured to release the battery when a battery present in the battery storing
20 compartment is pushed toward an uppermost charging station by the resilient member;
2. The battery charger according to claim 1, wherein each charging station comprises charging terminals adapted to provide current to the batteries and each charging station is configured to reinforce holding of batteries.
3. The battery charger according to claim 2, wherein each charging terminal is made of
25 conductive material and is configured to provide a resilient force sufficient to hold batteries during the charging process but adapted to release the battery when a battery is pushed by the resilient.
4. The battery charger according to claim 3, wherein the charging terminal are resilient metal strips.

5. The battery charger according to claim 1, wherein the battery charger further comprises an indicator means for indicating charging status of the battery charger.
6. The battery charger according to claim 1, wherein the battery charger further comprises an indicator means for indicating charging status of each charging station.
- 5 7. The battery charger according to any one of claims 5 or 6, wherein the indicator means is a light.
8. The battery charger according to claim 1, wherein the aperture is on top of the housing.
9. The battery charger according to claim 1, wherein the aperture is shaped according to
10 the shape of the type of battery to be inserted.
10. The battery charger according to claim 1, wherein a door covers the aperture.
11. The battery charger according to claim 10, wherein the door is resiliently mounted to the aperture.
12. The battery charger according to claim 1, wherein the storing compartment comprises
15 an upper portion and a lower portion, the upper portion being adapted to store a plurality of batteries and the lower portion being configured to receive only one battery.
13. The battery charger according to claim 1, wherein the resilient member comprises a handle attached to a spring, the housing being configured to receive the handle and to
20 limit the vertical movement of the handle, the handle comprising a bottom portion adapted to push a battering present in the storing compartment.
14. The battery charger according to claim 13, wherein the resilient member comprises a protrusion adapted to be received by guide rails of the housing.
15. The battery charger according to claim 1, the housing comprising a back wall, the
25 back wall comprising a holding member in between two charging stations, the holding member being adapted to hold a battery within the charging station and to displace the battery toward the guiding wall when a downward force is apply on the said battery.
16. The battery charger according to claim 1, wherein the charger further comprises a communication mean adapted to communicate with a network and a controller adapted

to send status of the charging process to client device in communication with the charger.

17. The battery charger according to claim 1, wherein the guiding wall further comprises an aperture adapted to access the charging stations.
- 5 18. A method for storing, charging and dispensing batteries, the method comprising:
- a) inserting a battery to be charged in an aperture of a charging device, the aperture being in communication with a storing compartment;
- b) activating a resilient member of the charger to displace a battery present in the storing compartment to an upper most charging station of a charging compartment through a passage portion in-between the storing compartment and the charging compartment, the charging compartment comprising a plurality of charging stations being vertically aligned and providing a resilient force sufficient to hold a battery present in the charging station during the charging process and configured to release the battery when a battery present in the battery storing compartment is pushed by the resilient member, the resilient member being configured to provide a force sufficient to release all batteries present in the charging stations; and
- 10 c) repeating step b) until a battery present in a lowermost charging station is ejected from the lowermost charging station.
- 15 19. The method according to claim 18, wherein the resilient member comprises a handle, the activating of the resilient member is done by downwardly pushing the handle.
- 20 20. The method according to claim 18, wherein the battery presents in the lowermost charging station is ejected in a battery charger under the lowermost charging station.
- 25 21. The method according to claim 18, wherein the aperture is shaped as the type of battery to be inserted, the method further comprising aligning the battery with the shape of the aperture.
22. The method according to claim 18, wherein the method further comprises communicating status of the charging device to at least one device in communication with the charging device.

30

* * *

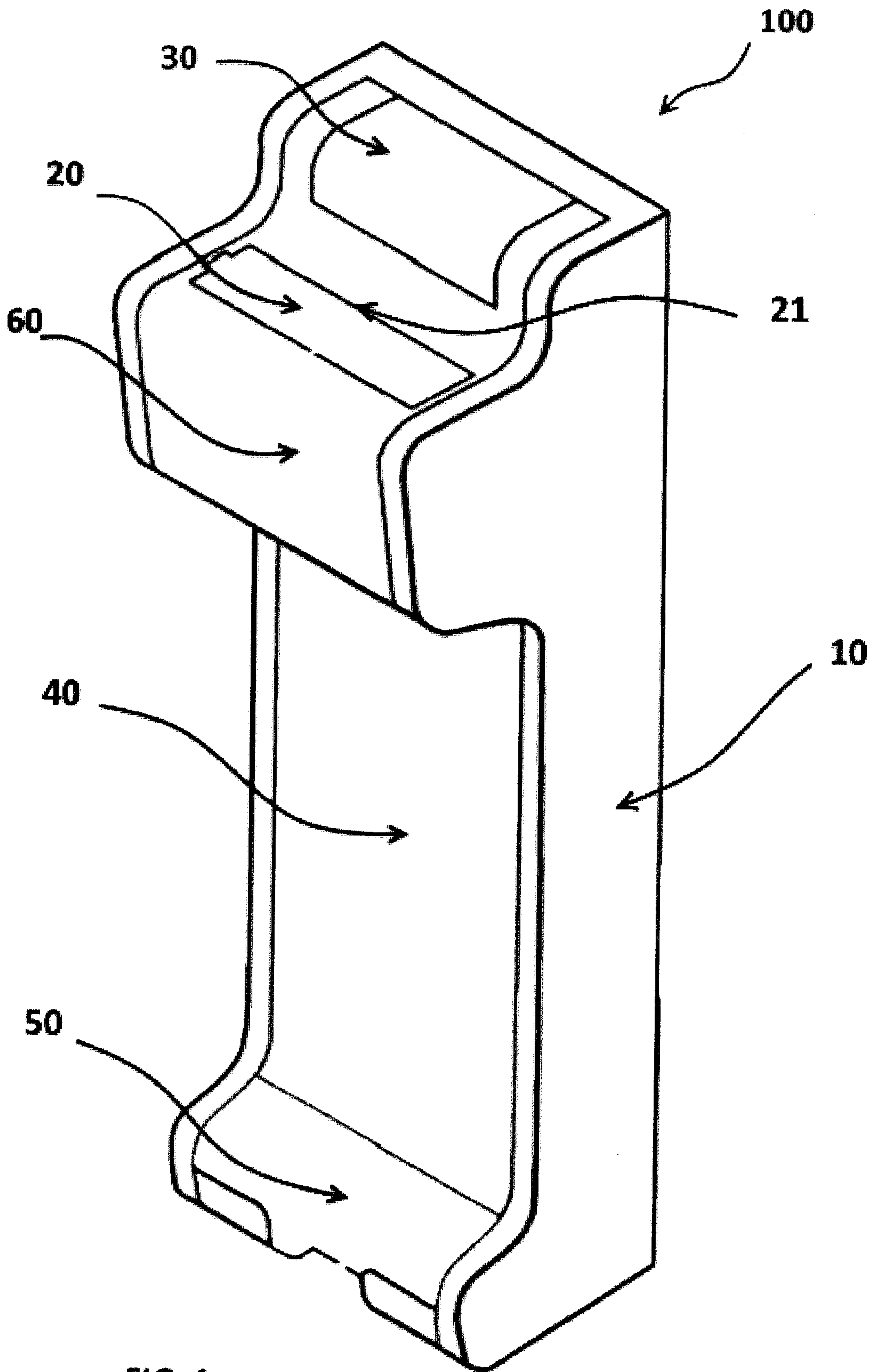

FIG. 1

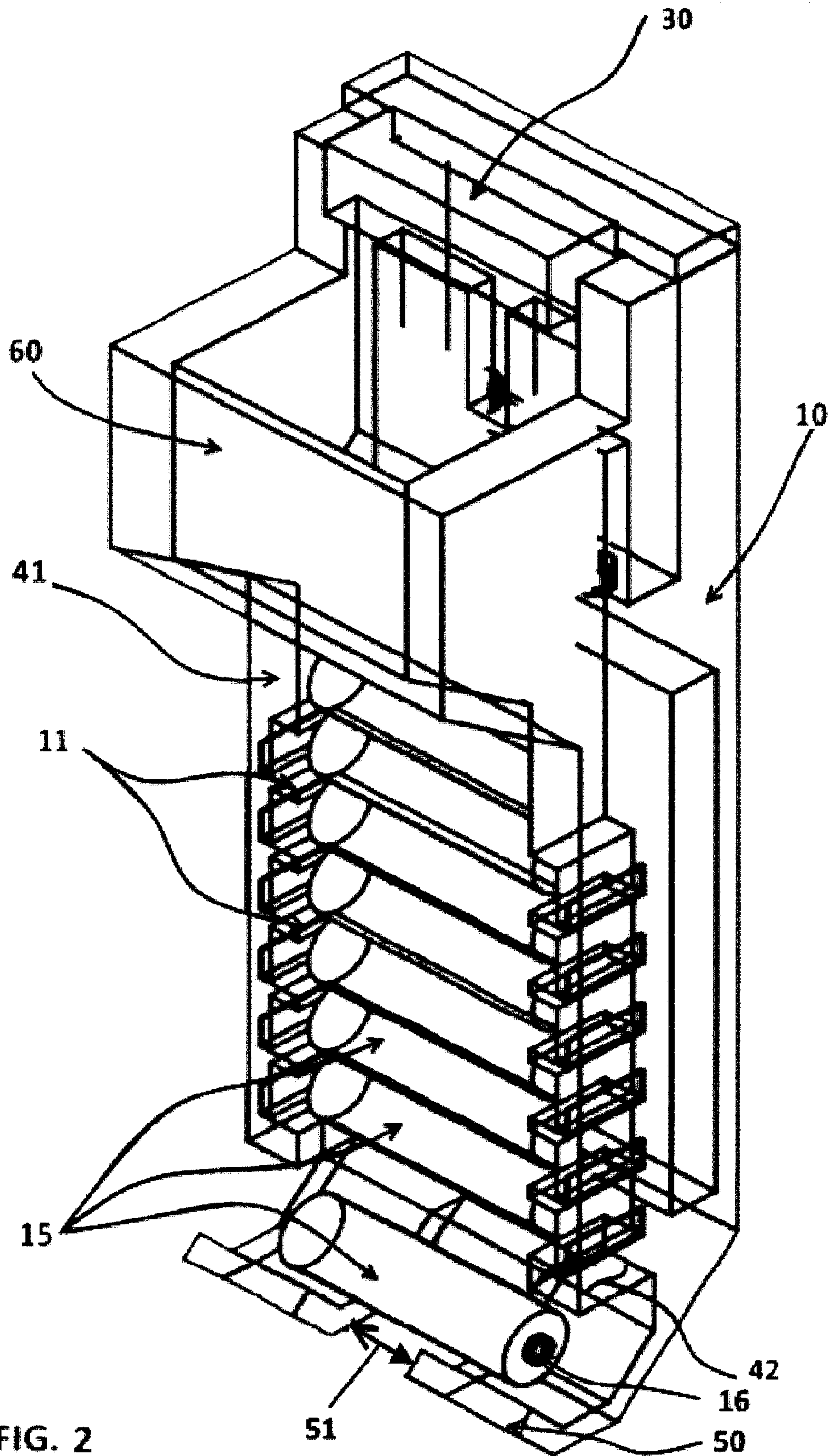

FIG. 2

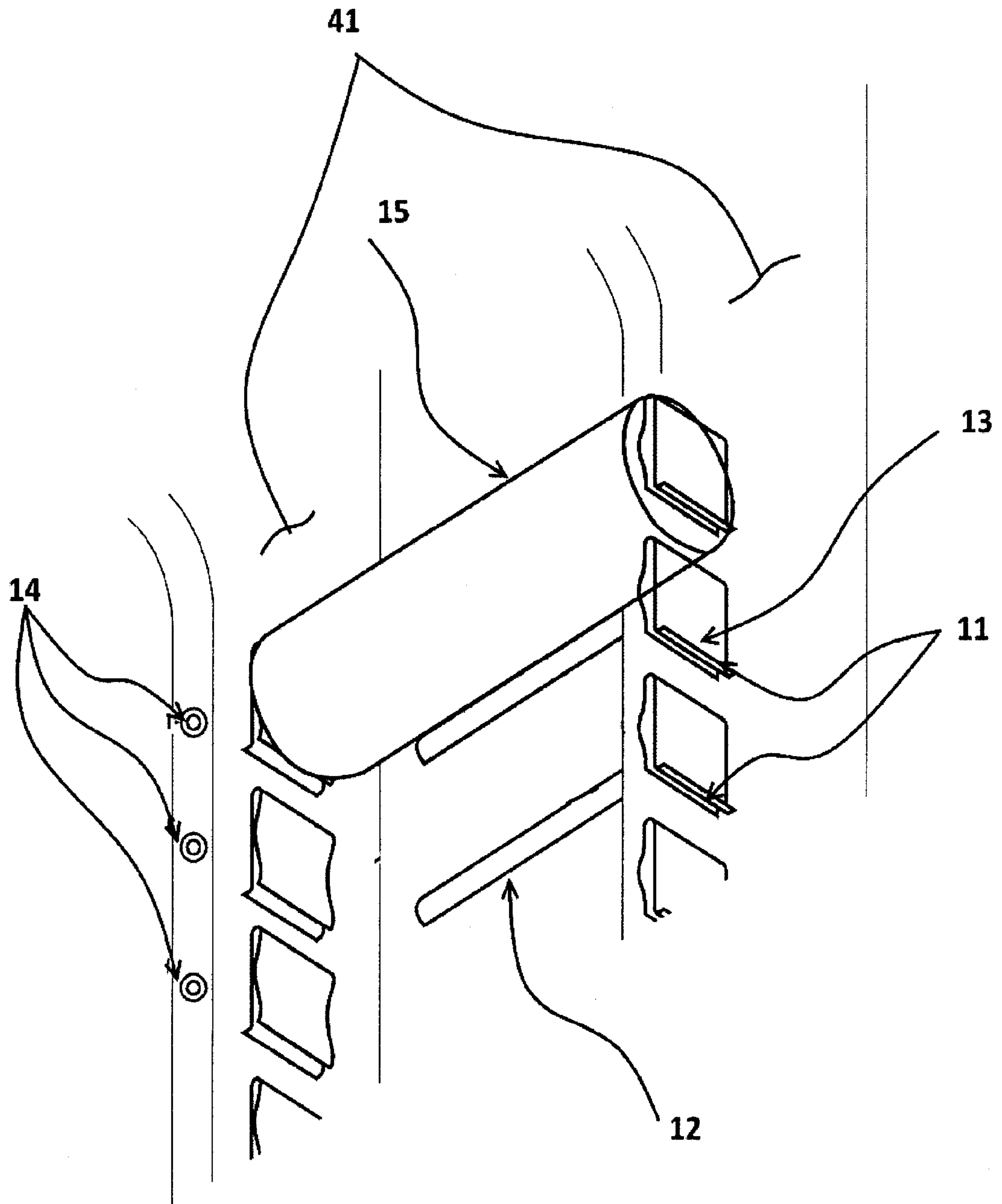

FIG. 3

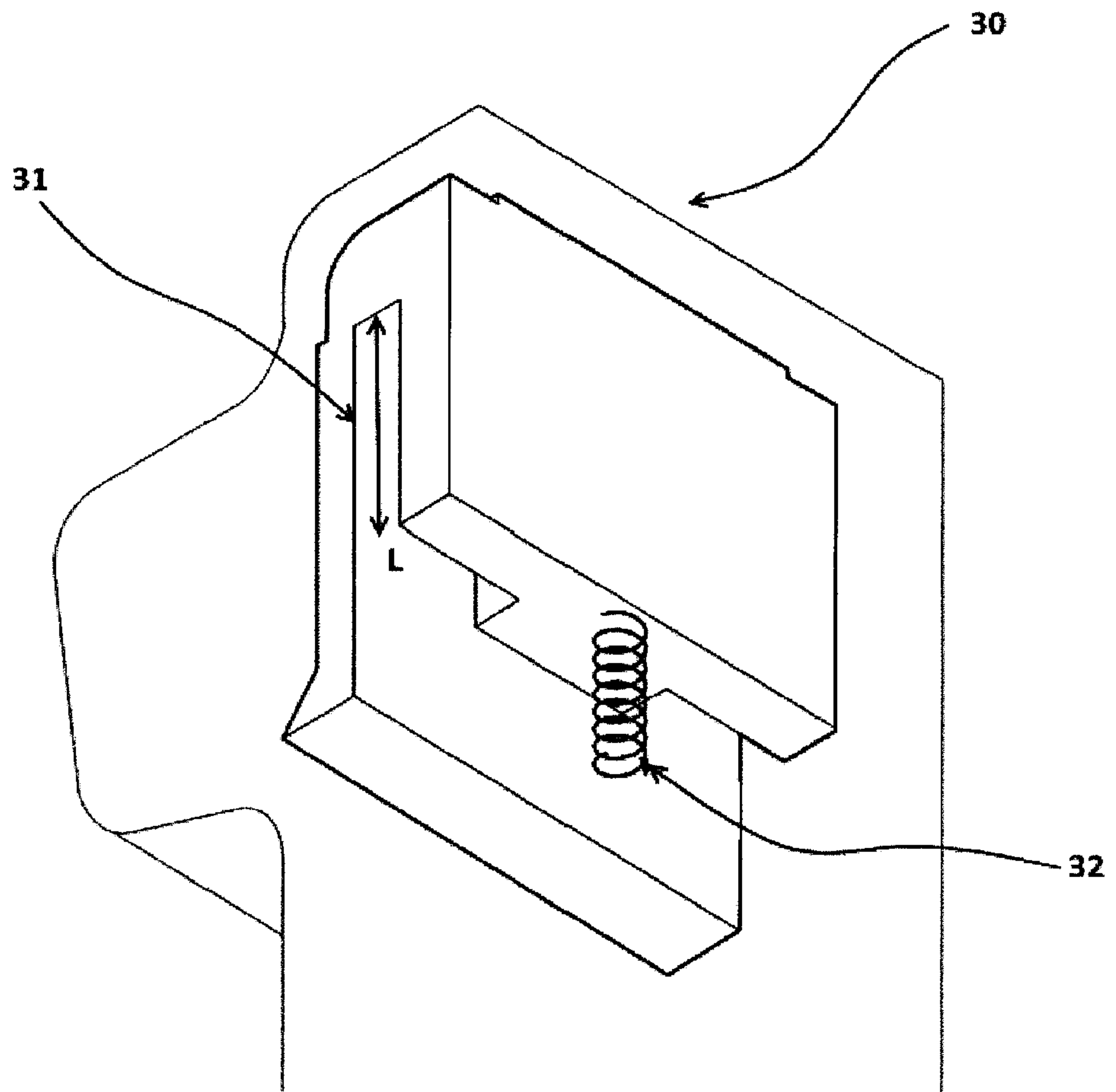

FIG. 4

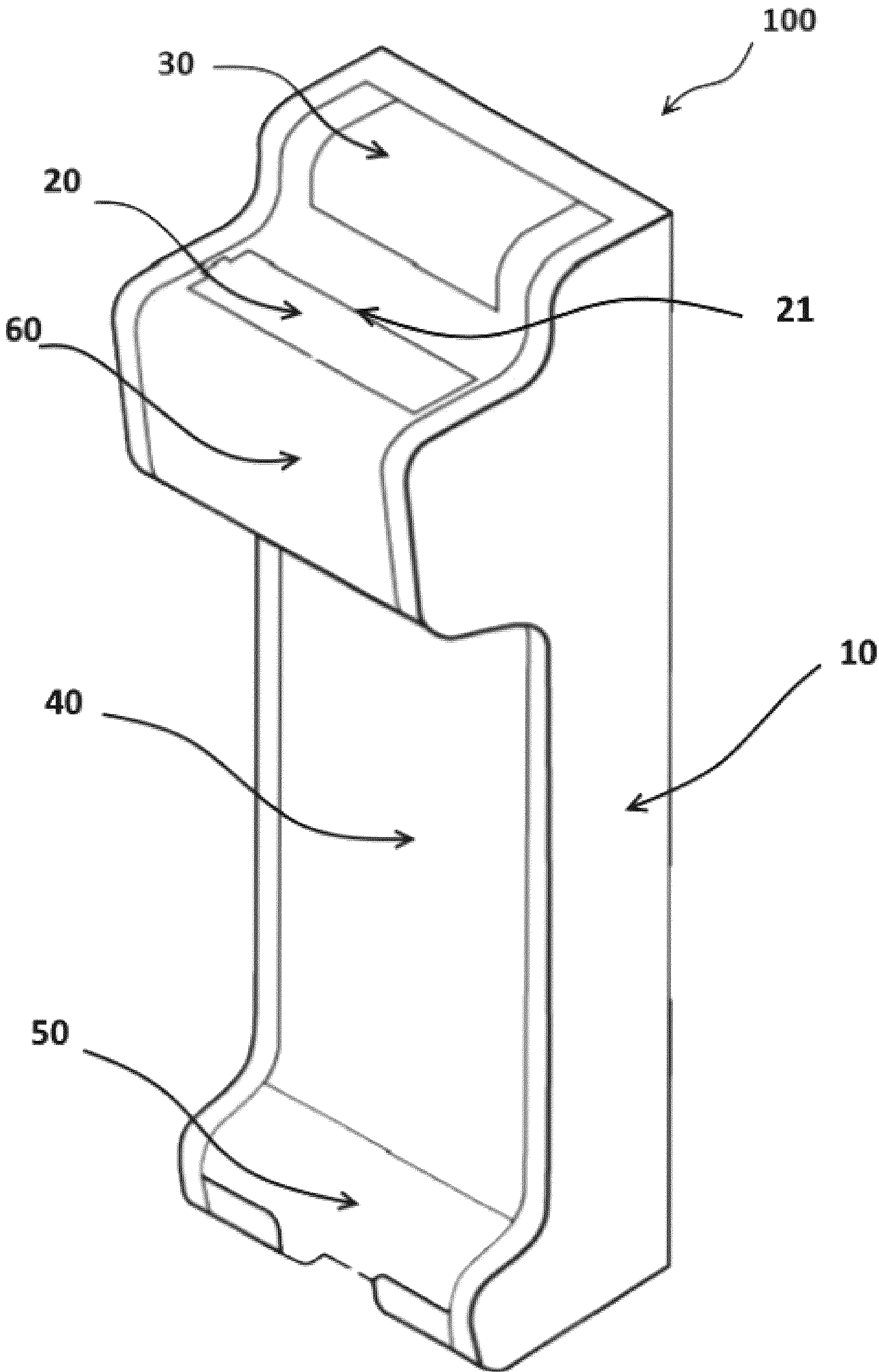

FIG. 1