

M. B. DISKIN.

MEANS FOR APPLYING PASTE TO THE COVERINGS FOR BOXES.

APPLICATION FILED JUNE 17, 1910.

985,574.

Patented Feb. 28, 1911.

4 SHEETS—SHEET 1.

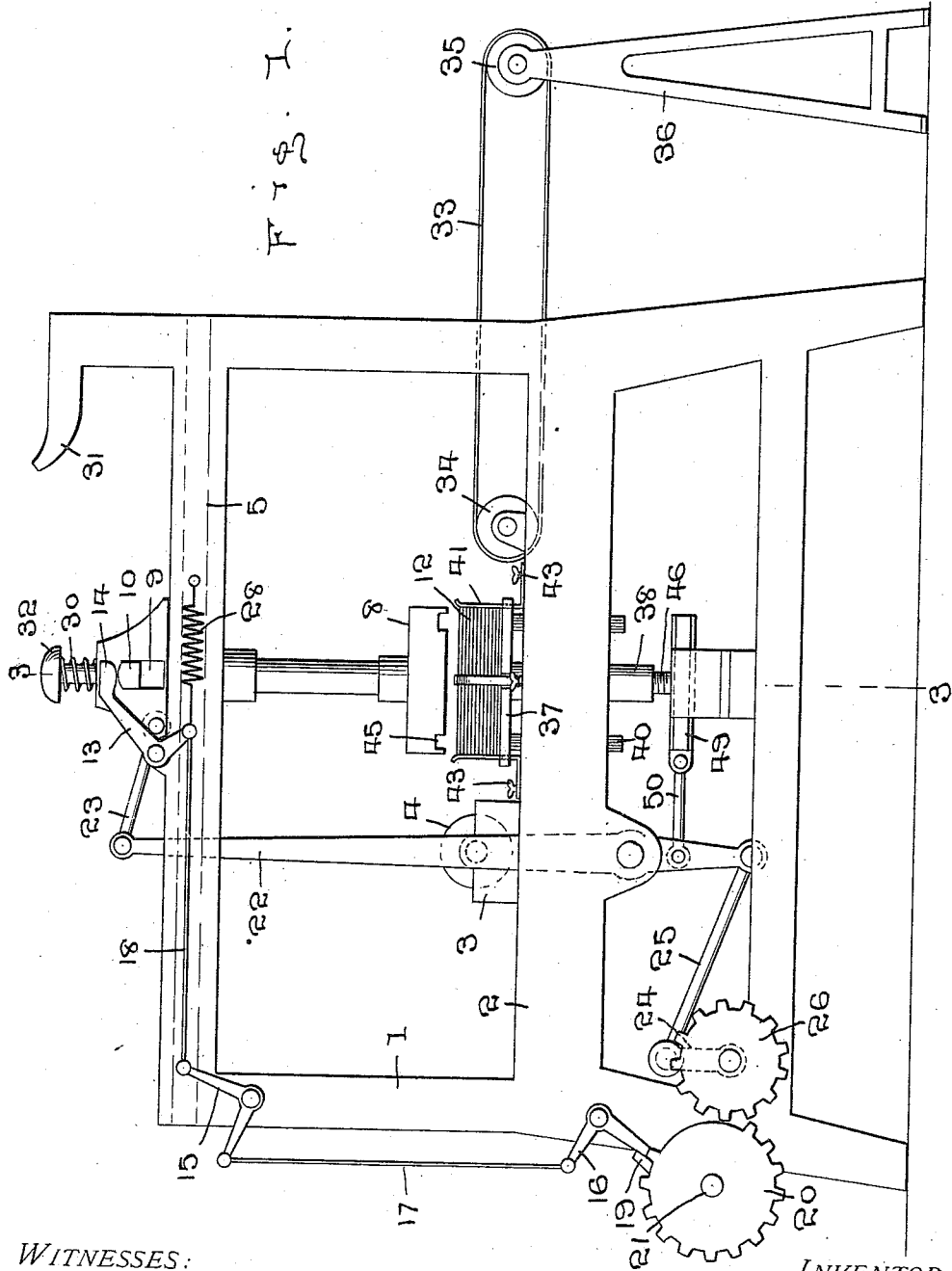

WITNESSES:

Thomas Riley  
M. Newcomb

JM. B. Diskin

INVENTOR

BY  
W. J. Fitzgerald & Co  
Attorneys

M. B. DISKIN.  
 MEANS FOR APPLYING PASTE TO THE COVERINGS FOR BOXES.  
 APPLICATION FILED JUNE 17, 1910.

985,574.

Patented Feb. 28, 1911.

4 SHEETS—SHEET 2.

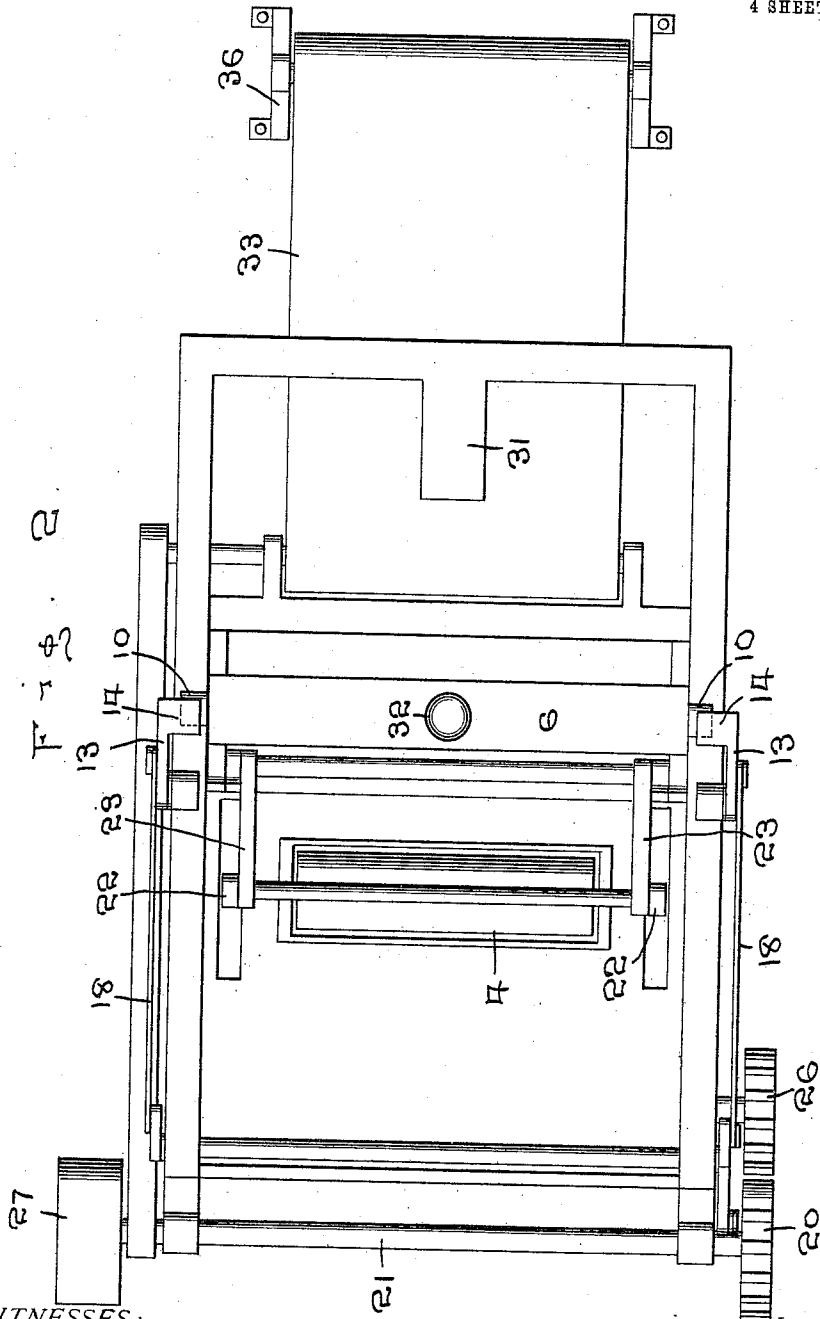

WITNESSES:

*Thos. Riley*  
*M. Newcomb*

M. B. Diskin

BY *W. J. FitzGerald & Co.*  
 Attorneys

M. B. DISKIN.  
 MEANS FOR APPLYING PASTE TO THE COVERINGS FOR BOXES.

985,574.

APPLICATION FILED JUNE 17, 1910.

Patented Feb. 28, 1911.

4 SHEETS—SHEET 3.

F 1 5 3.

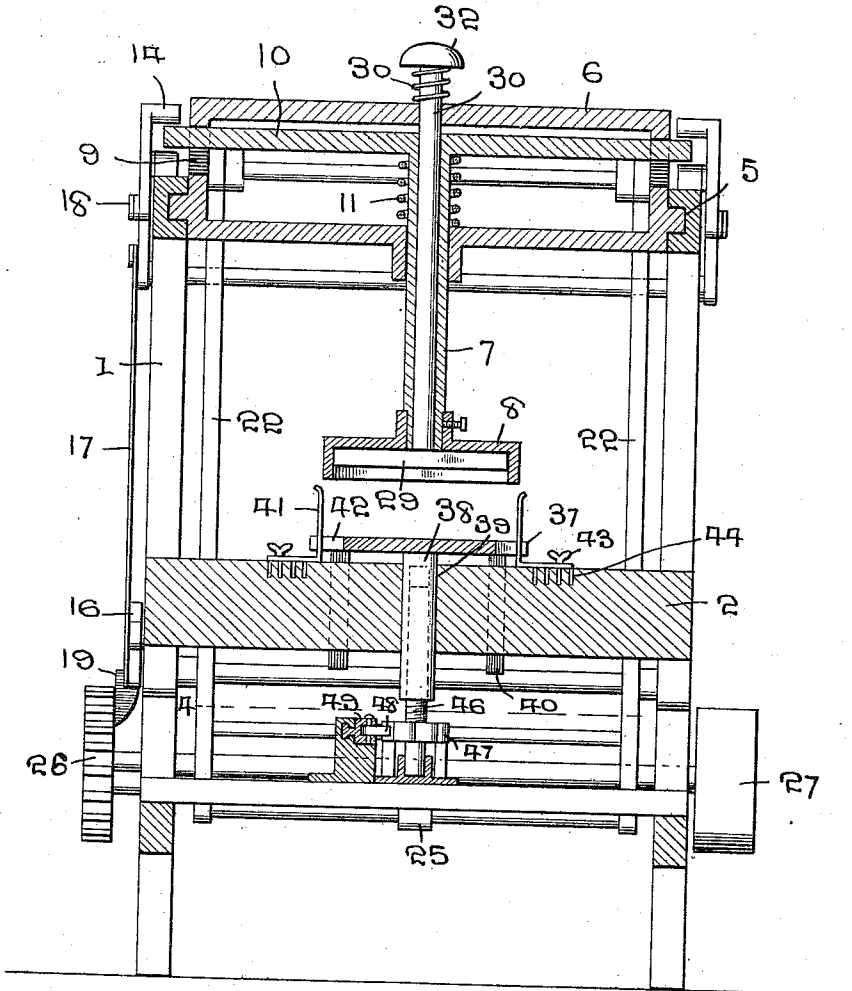

WITNESSES:

*Thomas Riley*  
*M. Newcomb*

M. B. Diskin  
 INVENTOR

BY  
*W. J. Fitzgerald*  
 Attorneys

M. B. DISKIN.

MEANS FOR APPLYING PASTE TO THE COVERINGS FOR BOXES.

APPLICATION FILED JUNE 17, 1910.

985,574.

Patented Feb. 28, 1911.

4 SHEETS—SHEET 4.

Fig. 4.

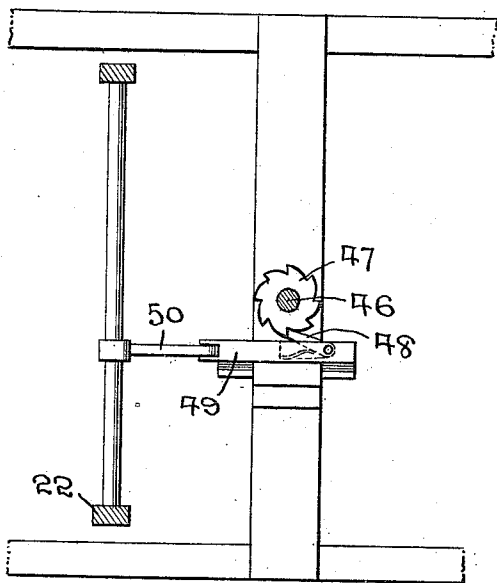

Fig. 5.

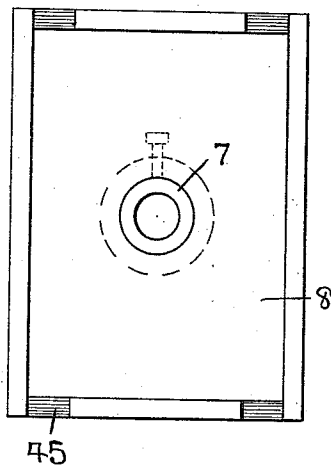
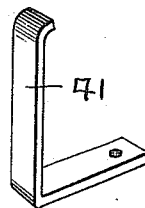
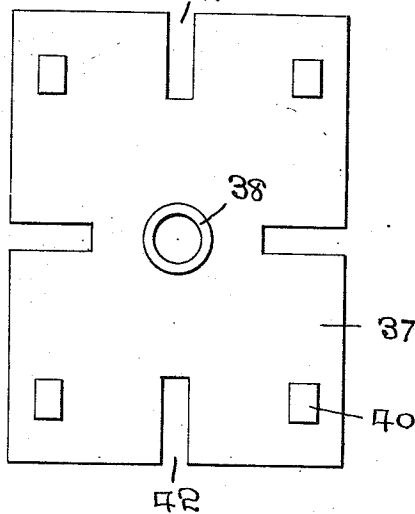
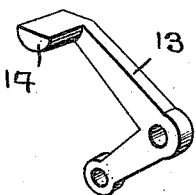

Fig. 6.

Fig. 8.

Fig. 7.



WITNESSES:

*Thos. W. Riley*  
*M. Newcomb*

INVENTOR  
M. B. Diskin

BY

*W. J. FitzGerald*  
Attorneys

# UNITED STATES PATENT OFFICE.

MOSES B. DISKIN, OF NEW YORK, N. Y.

MEANS FOR APPLYING PASTE TO THE COVERINGS FOR BOXES.

985,574.

Specification of Letters Patent. Patented Feb. 28, 1911.

Application filed June 17, 1910. Serial No. 567,530.

*To all whom it may concern:*

Be it known that I, MOSES B. DISKIN, a citizen of the United States, residing at New York, in the county of New York and State of New York, have invented certain new and useful Improvements in Means for Applying Paste to the Coverings for Boxes; and I do hereby declare the following to be a full, clear, and exact description of the invention, such as will enable others skilled in the art to which it appertains to make and use the same.

My invention relates to new and useful improvements in means for applying paste to the coverings for boxes and my object is to provide an adhesive applying device and means for covering the lower edges thereof with adhesive substance when the device is moved thereover.

A further object is to provide a plurality of the covers or wrappers for the boxes and position the same in the path of the adhesive applying device.

A further object is to provide means for lowering the adhesive applying device into engagement with the uppermost wrapper.

A further object is to provide means for moving a plunger into engagement with the wrapper to disengage the wrapper from the adhesive applying device.

A further object is to provide means for disposing of the wrapper when disengaged from the adhesive applying device.

A further object is to provide automatically operated means for raising the wrappers successively as a wrapper is removed from the bunch, and, a further object is to provide adjustable guides for the bunch of wrappers, whereby wrappers of various sizes may be retained in desired position.

Other objects and advantages will be hereinafter referred to and more particularly pointed out in the specification and claims.

In the accompanying drawings which are made a part of this application, Figure 1 is a side elevation of the device showing the adhesive applying device in position to be lowered into engagement with the wrappers. Fig. 2 is a top plan view thereof. Fig. 3 is a transverse sectional view as seen on line 3—3 Fig. 1. Fig. 4 is a detail sectional view as seen on line 4—4 Fig. 3. Fig. 5 is a bot-

tom plan view of the device. Fig. 6 is a bottom plan view of the wrapper support-  
ing tray. Fig. 7 is a perspective view of a lever employed for lowering the device, and, Fig. 8 is a perspective view of one of the guides for the wrappers.

Referring to the drawings in which similar reference numerals designate corresponding parts throughout the several views, 1 indicates a frame, which may be constructed in the usual or any preferred manner and 2 indicates a bed plate for the frame.

Positioned upon the bed plate 2 is a tank 3, in which is to be placed liquid glue or other adhesive substance and rotatably mounted in said tank is a roller 4, substantially one half of the roller projecting above the tank.

Slidably mounted in channels 5 at the upper portion of the frame 1 are the ends of a cross head 6, depending from which is a sleeve 7, to the lower end of which is removably secured an adhesive applying device or picker 8. The cross head 6 is formed of a top and bottom wall and end walls between said top and bottom walls and projecting through slots 9 in the end walls is a cross bar 10, which is attached to the upper end of the sleeve 7, the cross bar being normally retained adjacent the top wall of the cross head by means of a spring 11, which is positioned around the sleeve and between the cross bar and the bottom wall of the cross head.

The picker 8 is open at its lower edge so that when the picker is moved over the roller, the adhesive substance will only adhere to the lower edge thereof and by this construction, when the picker is lowered into engagement with the wrappers 12, the adhesive substance will only engage the outer edges of the wrappers.

The picker 8 is moved downwardly and into engagement with the uppermost wrapper by means of a lever 13, which lever is pivoted to the frame 1 and has a lateral extension 14, the under face of which is curved and engages the projecting ends of the cross bar 10, when the lever is rocked to lower the picker. The lever 13 is operated to lower the picker 8 through the medium of a pair of bell crank levers 15 and 16 respectively,

which are pivoted to the frame 1, one arm of each of the bell crank levers being connected together by a rod 17 and one arm of the bell crank lever 15 is connected to the lever 13 by means of a rod 18, so that when said bell crank levers 15 and 16 are rocked, the end of the lever 13 having the extension thereon will be lowered, thereby forcing downwardly the picker 8. One arm of the bell crank lever 16 is engaged by a tongue 19 carried by a gear 20, said gear being mounted upon a shaft 21 at one end of the frame and the tongue is so placed that when it moves into engagement with the bell crank lever 16, the ends of the cross bar 10 will be immediately below the extension on the lever 13 and as the gear 20 is rotated, the bell crank levers 15 and 16 will be rocked and the end of the lever 13 having the extension thereon lowered.

The cross head 6 and parts carried thereby are moved lengthwise of the frame 1 through the medium of a pair of bars 22, which bars are pivoted adjacent their lower ends to the frame 1, the upper ends of the bars being connected to the cross head 6 by links 23, while the lower ends of the bars are connected to a crank shaft 24 through the medium of links 25 and it will be readily seen that as the crank shaft is rotated, the bars 22 will be rocked back and forth, thereby moving the cross head and picker connected thereto longitudinally of the frame. The crank shaft 24 is operated through the medium of a cog 26, the teeth of which are adapted to mesh with the teeth on the gear 20 and power is applied to the shaft 21 and gear 20 through the medium of a belt wheel 27 attached to one end of the shaft 21. As it is necessary to have the picker and parts carrying the same remain in position above the wrappers until the picker can be lowered and again raised, a portion of the teeth are removed from the gear 20 and said stripped portion of the gear will be turned adjacent the cog 26 when the picker is positioned above the wrappers and the tongue 19 is likewise positioned on the gear 20 so as to engage the bell crank lever 16 simultaneously with the disengagement of the teeth of said gear from the cog 26. By this arrangement, it will be seen that while the cog and parts attached thereto are stationary, the picker will be moved into engagement with the wrappers.

When the tongue 19 is released from the bell crank lever 16, the lever 13 is returned to its elevated position by means of a spring 28, one end of which is attached to the frame 1 and the opposite end to the lever 13, thus holding the extension 14 on said lever in such position that the ends of the cross bar 10 can readily move back and forth below the extension without engaging the same.

In operation, the picker 8 is moved over

the roller 4, which will cause said roller to rotate and carry the adhesive substance upwardly and into engagement with the lower edge of the mandrel so that when the picker is lowered into engagement with the uppermost wrapper, the edges of the wrappers will be supplied with the adhesive substance. After the crank shaft has rotated a certain distance, the picker and parts carrying the same start to move in the opposite direction until the picker is positioned immediately over the bunch of wrappers. As the picker reaches this point, that part of the gear 20 stripped of the teeth will have moved adjacent the cog 26 so that said cog and parts operated thereby will remain stationary until the teeth at the opposite end of the stripped portion again moves into engagement with the teeth on the cog. At the same time that the stripped portion of the gear comes into registration with the cog, the tongue on said gear will engage the bell crank lever 16 and operate the lever 13, thereby moving the picker downwardly and into engagement with the uppermost wrapper. As soon as the tongue 19 has passed out of engagement with the bell crank lever 16 and the teeth on the gear move into engagement with the teeth on the cog, the picker will continue its movement on the frame until the full stroke of the bars 22 has been completed in one direction. In view of the adhesive substance on the picker, the uppermost wrapper will adhere thereto and be carried thereby to one end of the frame and in order to release the wrapper from the picker, a plunger 29 is mounted within the picker and is lowered into engagement with the wrapper by extending a shank 30 upwardly through the sleeve 7 and above the upper bar of the cross head 6, the upper end of the shank being so positioned as to pass below a trip 31 at one end of the frame 1. The free end of the trip is curved upwardly so that the end of the shank will readily pass below the same, while the knob 32 at the upper end of the shank is rounded to prevent an impact or jar when the shank moves into engagement with the trip. As the wrapper is released from the picker, it descends upon a belt 33 and is thereby carried from the frame to any suitable point, one end of the belt being disposed around a roller 34 on the frame, while the opposite end of the belt passes around a similar roller 35 rotatably mounted in an adjustable frame 36 and by having said frame movable, the belt may be extended to any distance from the frame 1.

The wrappers are positioned upon a tray or pallet 37, said tray being mounted upon the bed plate 2 by extending downwardly from the center of said tray a socket 38, said socket being disposed through an opening 39 in the bed plate. Extending downwardly

from the lower face of the tray are guide arms 40, which also project through the bed plate and serve to hold the tray against rotation, as well as guiding the same. The 5 wrappers are retained in uniform position upon the tray by means of guides 41, said guides being positioned at the ends and sides of the tray and as the wrappers vary in length and width, the tray is provided with 10 notches 42, into which the guides may enter in setting the guides to receive the different sized wrappers. The guides are held in position on the bed plate 2 by means of clamping screws 43, which pass through the horizontal portions of the guides and enter 15 threaded seats 44 in the bed plate.

As the corners of the wrappers overlap each other when folded and placed upon the box, it is preferable not to place the adhesive substance on such overlapping portions and to this end, the end walls of the picker are cut away for a distance, as shown at 45 in Figs. 1 and 5.

With each operation of the picker, a 25 wrapper is removed from the bunch and in order to maintain the uppermost wrapper a proper distance from the picker, a screw 46 is entered in the lower end of the socket 38, said socket being interiorly threaded to 30 receive the screw and by giving the screw a slight rotation each time a wrapper is removed therefrom, said wrappers will be gradually fed upwardly and maintained a proper distance from the picker. The screw 35 46 is operated by placing a ratchet wheel 47 on the screw 46 and in position to be engaged by a spring pressed pawl 48, which pawl is slidably mounted on parts of the frame 1. The slide block 49 to which the 40 pawl is attached is moved back and forth endwise by attaching to the bars 22 a connecting link 50, the opposite end of the link being attached to the slide block and it will be readily seen that when the block is moved 45 in one direction, the pawl will yield and pass the teeth on the ratchet, but when moved in the opposite direction, the pawl will engage one of the teeth on the ratchet and partially rotate the same, thereby automatically feeding the bundle of wrappers toward the picker.

By this construction, it will be readily seen that the adhesive substance can be applied to the wrappers without said wrappers 55 becoming soiled or in any manner damaged and as the wrappers are adapted to fit loosely over the boxes around which they are placed, the positioning of the adhesive substance along the edges of the wrappers will place 60 the pasted portion of the wrapper on the inside of the box or cover, over which the wrapper is placed. It will further be seen that the action of the device will be positive and that a wrapper will be supplied with 65 the adhesive substance with each operation

of the picker and further that said wrapper when so pasted and released from the picker will be removed to a convenient point for applying the same to a box or other object. It will further be seen that by providing the 70 guides in connection with the tray upon which the bundle of wrappers is placed, said wrappers will be kept in proper alignment and in position to receive the picker at all times. 75

What I claim is:—

1. In a device for applying adhesives to wrappers, the combination with a frame, of a carriage movable longitudinally thereon, a tray at one point on said frame adapted 80 to support a plurality of wrappers, an adhesive applying device on said carriage, means to lower said device into engagement with said wrappers, a stripping device associated with said adhesive applying device 85 and movable therewith, and means on said frame at one limit of travel of said carriage adapted to operate said stripping device.

2. In a device for applying adhesives to wrappers, the combination with a frame, of 90 a carriage movable longitudinally thereon, an adhesive applying device supported by said carriage, means at one end of travel of said carriage adapted to supply said adhesive to said device, a tray adapted to support a plurality of wrappers, means to periodically stop the movement of said carriage above said wrappers, means to automatically depress said adhesive applying device into engagement with the uppermost 100 wrapper, a stripper carried by said device, and an extension on said frame at the other limit of travel of said carriage adapted to operate said stripper.

3. In a device for applying adhesives to 105 wrappers, in combination, a supporting frame, a tray to support a plurality of wrappers, an adhesive supplying receptacle adjacent thereto, a carriage adapted to move longitudinally over said receptacle and tray, 110 an adhesive applying device supported by said carriage, means to drive said carriage, the movement thereof being periodically interrupted at a predetermined point, means to move said adhesive applying device into 115 contact with said wrappers whenever the movement of said carriage is interrupted, a stripping device associated with said adhesive applying device and movable therewith, and means in the path of said stripping 120 device adapted to operate the same whenever the carriage reaches one of its limits of travel.

4. In a device of the class described, in combination, a frame, an adhesive applying device slidably mounted in said frame, means 125 to apply an adhesive to the lower edge thereof, means to move said device back and forth on the frame and means to lower said device at a predetermined point, a tray to support 130

a plurality of wrappers, means to automatically elevate the tray when a wrapper has been removed therefrom, a stripper associated with said device and movable there-  
 5 with, and means carried by said frame and disposed in the path of said stripper adapted to operate the same.

In testimony whereof I have signed my name to this specification in the presence of two subscribing witnesses.

MOSES B. DISKIN.

Witnesses:

C. S. FRYE,  
 M. NEWCOMB.

---

Copies of this patent may be obtained for five cents each, by addressing the "Commissioner of Patents, Washington, D. C."

---