

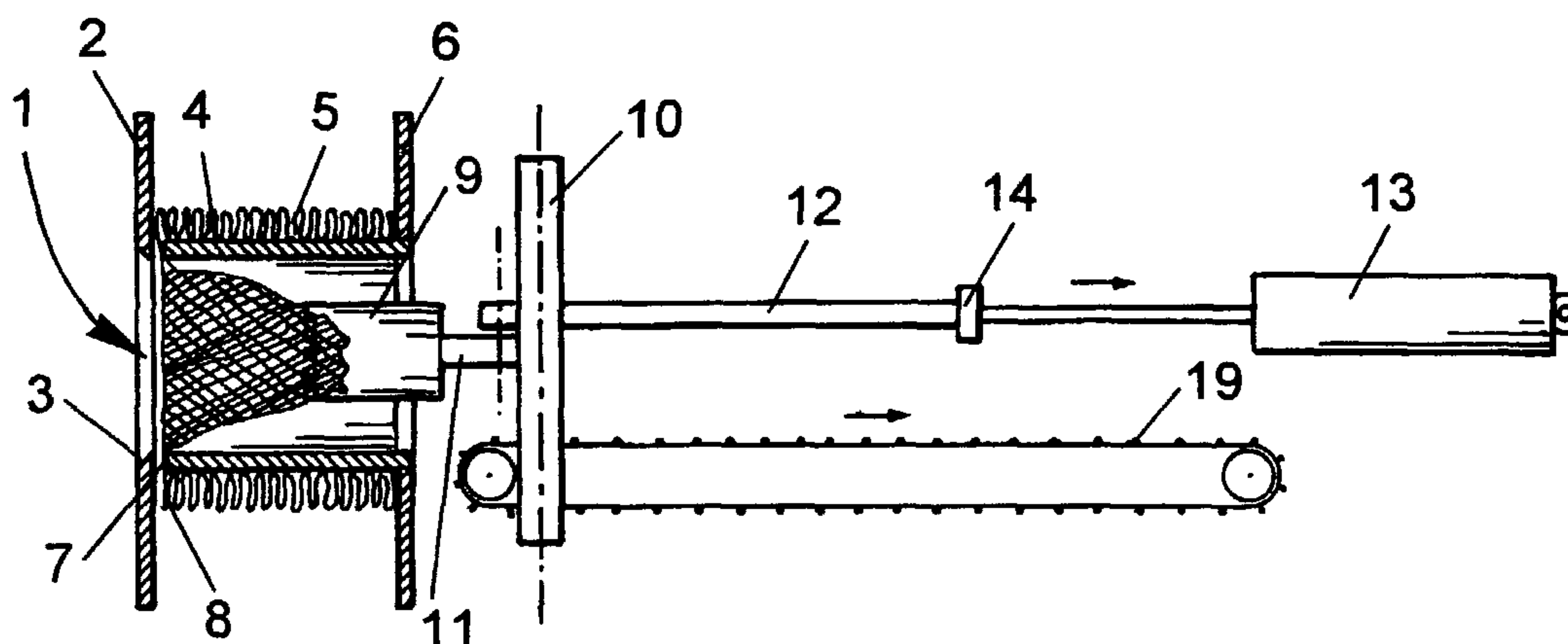

(86) Date de dépôt PCT/PCT Filing Date: 2001/08/16
 (87) Date publication PCT/PCT Publication Date: 2002/02/21
 (85) Entrée phase nationale/National Entry: 2003/02/14
 (86) N° demande PCT/PCT Application No.: DK 2001/000543
 (87) N° publication PCT/PCT Publication No.: 2002/014155
 (30) Priorité/Priority: 2000/08/16 (PA 2000 01222) DK

(51) Cl.Int.⁷/Int.Cl.⁷ B65B 25/02
 (71) Demandeur/Applicant:
THOMSEN, CLAUS, DK
 (72) Inventeur/Inventor:
THOMSEN, CLAUS, DK
 (74) Agent: OGILVY RENAULT

(54) Titre : DISPOSITIF ET PROCÉDE DESTINES A METTRE DES ARBRES SOUS MANCHON DE RESILLE
 (54) Title: A DEVICE AND A METHOD FOR THE NETTING OF TREES



(57) Abrégé/Abstract:

A device for the netting of trees, which device comprises a supply opening (1) and a device for the application of a net sleeving (5) around a tree when the latter is carried through the device. The device for the application of a net sleeving (5) around a tree is separated from the supply opening (1) and comprises a netting tube (4), on the outside of which the net (5) is located, the end of the net (5) being bent around that end (7) of the netting tube (4) that faces towards the supply opening (1) and extends into the netting tube (4). Also a method for the netting of trees, wherein the net (5) is applied to the tree inside a netting tube (4) located immediately after the supply opening (1).



(12) INTERNATIONAL APPLICATION PUBLISHED UNDER THE PATENT COOPERATION TREATY (PCT)

(19) World Intellectual Property Organization
International Bureau



(43) International Publication Date
21 February 2002 (21.02.2002)

PCT

(10) International Publication Number
WO 02/14155 A1

(51) International Patent Classification⁷: B65B 25/02

(21) International Application Number: PCT/DK01/00543

(22) International Filing Date: 16 August 2001 (16.08.2001)

(25) Filing Language: Danish

(26) Publication Language: English

(30) Priority Data:
PA 2000 01222 16 August 2000 (16.08.2000) DK

(71) Applicant and

(72) Inventor: THOMSEN, Claus [DK/DK]; Højvang 4,
DK-5560 Aarup (DK).

(74) Agent: HOFMAN-BANG ZACCO A/S; Hans
Bekkevolds Allé 7, DK-2900 Hellerup (DK).

(81) Designated States (national): AE, AG, AL, AM, AT, AT
(utility model), AU, AZ, BA, BB, BG, BR, BY, BZ, CA,

CH, CN, CO, CR, CU, CZ, CZ (utility model), DE, DE
(utility model), DK, DK (utility model), DM, DZ, EC, EE,
EE (utility model), ES, FI, FI (utility model), GB, GD, GE,
GH, GM, HR, HU, ID, IL, IN, IS, JP, KE, KG, KP, KR, KZ,
LC, LK, LR, LS, LT, LU, LV, MA, MD, MG, MK, MN,
MW, MX, MZ, NO, NZ, PL, PT, RO, RU, SD, SE, SG, SI,
SK, SK (utility model), SL, TJ, TM, TR, TT, TZ, UA, UG,
US, UZ, VN, YU, ZA, ZW.

(84) Designated States (regional): ARIPO patent (GH, GM,
KE, LS, MW, MZ, SD, SL, SZ, TZ, UG, ZW), Eurasian
patent (AM, AZ, BY, KG, KZ, MD, RU, TJ, TM), European
patent (AT, BE, CH, CY, DE, DK, ES, FI, FR, GB, GR, IE,
IT, LU, MC, NL, PT, SE, TR), OAPI patent (BF, BJ, CF,
CG, CI, CM, GA, GN, GQ, GW, ML, MR, NE, SN, TD,
TG).

Published:

— with international search report

For two-letter codes and other abbreviations, refer to the "Guidance Notes on Codes and Abbreviations" appearing at the beginning of each regular issue of the PCT Gazette.

(54) Title: A DEVICE AND A METHOD FOR THE NETTING OF TREES

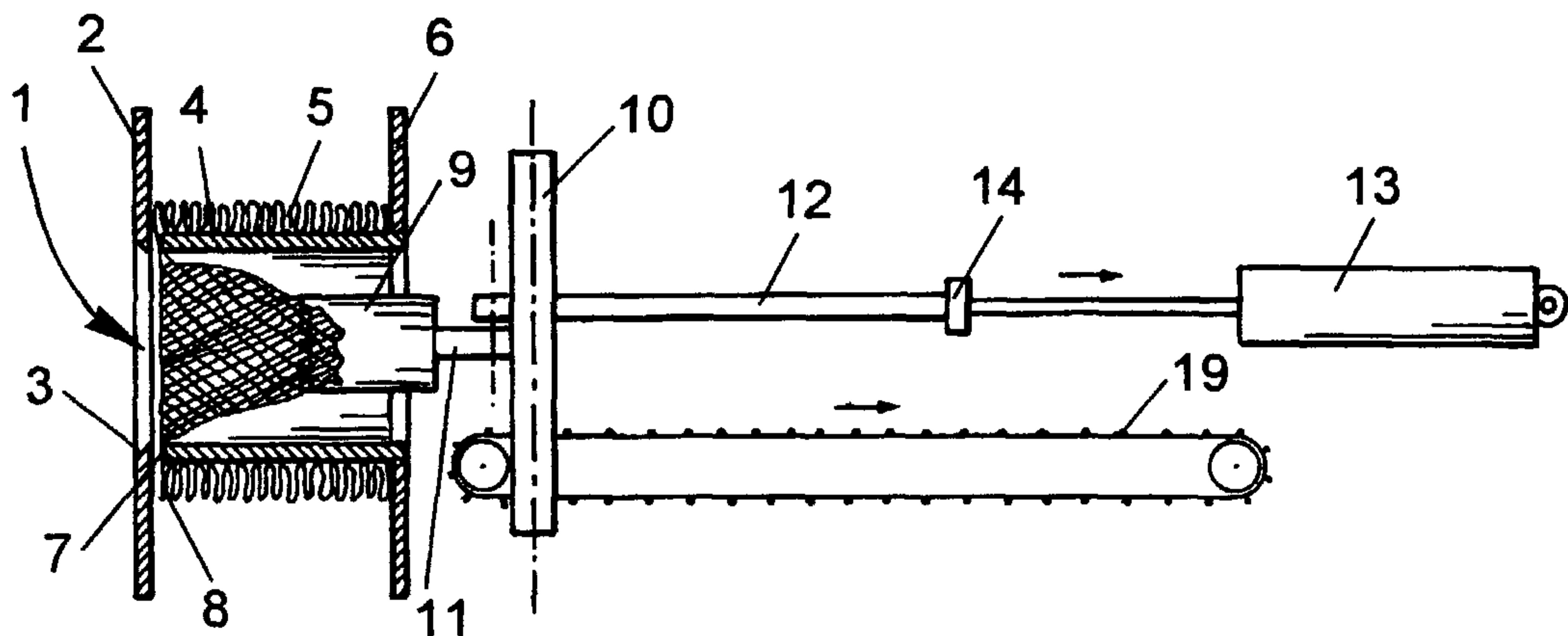

(57) Abstract: A device for the netting of trees, which device comprises a supply opening (1) and a device for the application of a net sleeving (5) around a tree when the latter is carried through the device. The device for the application of a net sleeving (5) around a tree is separated from the supply opening (1) and comprises a netting tube (4), on the outside of which the net (5) is located, the end of the net (5) being bent around that end (7) of the netting tube (4) that faces towards the supply opening (1) and extends into the netting tube (4). Also a method for the netting of trees, wherein the net (5) is applied to the tree inside a netting tube (4) located immediately after the supply opening (1).



WO 02/14155 A1

A device and a method for the netting of trees

The invention relates to a device and a method for the netting of trees as featured in the preamble to claim 1 and claim 13.

5

Usually such devices comprise a supply opening that is configured at the end of a funnel-shape tube being, at its opposite end, connected to a cylindrical tube. The device is positioned horizontally, the tree to be netted being pressed with its cut-off end first into the wide end of the funnel-shaped tube and continuing into the cylindrical tube. A gripper claw or hook can be provided for pulling the tree through the cylindrical tube. A sleeving or hose-shaped net has been pushed over the cylindrical tube, the end of the net being suspended beyond the end thereof. When a tree is pushed through the funnel-shaped tube with its cut-off end first, the free end of the net is secured to the tree – either by a knot being tied at the end of the net or by the net being secured relative to the tree in any other manner, and the net is subsequently pulled off the cylindrical tube as the tree is pulled there through. When the tree is pulled completely through the cylindrical tube, the net is cut off, which is preferably performed manually – and the tree is netted.

20

This prior art device for the netting of trees suffers from the overall drawback that the net around the netted trees is not very tight, it being effectively wrapped around the tree only when the latter has left the cylindrical tube. Hereby the branches of the tree are allowed to partially expand again prior to being "caught" by the net. The fact that the net is not stretched to a significant degree in its longitudinal direction either also contributes to the not very tight netting of the trees. Besides, slack netting also means that more net than actually needed is consumed.

30

Also, this device is associated with the drawback that – when used for large scale operation where a large number of trees are netted – three persons are usually required to complete the operation: one for feeding trees to the device, one for cutting off the sleeving, and one for discharging the netted trees from the device.

Finally, this prior art device is fairly long, partly due to the protracted length of the funnel-shaped tube and the cylindrical tube, and partly because the trees to be netted are pulled all the way through the funnel-shaped tube by means of a pulling device. The friction that occurs between the tree to be netted and the inside of the cylindrical tube is also of a significant magnitude, in particular when the cylindrical tube is long as is the case with the prior art device.

It is the object of the present invention to provide a device and a method for the netting of trees, said device and said method overcoming the above-described drawbacks of the prior art.

This is accomplished by configuring the device featured in the preamble to claim 1 as featured in the characterising part of claim 1.

Besides it is accomplished by the method featured in the preamble to claim 13 further featuring the step described in the characterising part of claim 13.

Hereby it is obtained primarily that the net around the trees becomes considerably tighter than was the case with the prior art devices where the net is not applied until the tree leaves the cylindrical tube. This is obtained partly by the net being applied within the netting tube while the tree is completely compressed, and partly by the net being stretched in its longitudinal direction when pulled beyond the edge of the netting tube and through it. By tightening the net in this manner a reduced net consumption is also obtained. Finally the friction between the tree and the inside of the netting tube is reduced compared to the prior art, the net located between the tree and the netting tube servicing as an anti-friction layer.

The dependent claims feature particularly preferred embodiments that further improve the device according to the invention.

The invention will now be described with reference to the drawing, wherein

Figure 1 is an explanatory sketch showing a device for the netting of trees according to the invention;

5 Figure 2 shows an explanatory cross section of the device; and

Figure 3 shows a tree partially pulled through the device shown in Figures 1 and 2.

10 As will appear from Figures 1 and 2, a preferred explanatory embodiment of a device for the netting of trees in accordance with the invention comprises a supply opening 1 provided, in the embodiment shown, in a plate 2 in the form of a circular opening having an inclined edge 3, whereby the supply opening 1 is caused to have a larger diameter on the forwardly oriented side of the
15 plate 2 than on the opposite side.

Immediately behind the supply opening 1 and at a short distance therefrom, a netting tube 4 is provided that consists of a circular tube having an internal diameter that corresponds essentially to the smallest diameter of the supply
20 opening 1, ie corresponds to the dimension of the supply opening 1 in the plate 2 at the side that faces towards the netting tube 4. At the outside, the netting tube 4 is provided with a sleeve- or hose-shaped net 5 that is compressed in the longitudinal direction, as shown, which means that – as a starting point – it fills the netting tube 4 along the entire longitudinal expanse
25 thereof. Such compression of the net 5 enables positioning of many metres of net sleeving 5 on the comparatively short netting tube 4.

At the rear end the netting tube 4 is provided with a flange 6 that constitutes an end stop for the net 5, whereby it is kept on the netting tube 4. At the front
30 end the end stop of the net 5 is constituted by the plate 2 with the supply opening 1, the plate 2 being, however, located a short distance from the netting tube 4 to allow the net 5 to be pulled around the front end 7 of the netting tube 4, whereby this end of the net 5 can be bent into the netting tube 4, as shown in Figure 2. The distance between the front edge 7 of the netting

tube 4 and the plate 2 has exactly such expanse that there is room for the net 5 to be located there between. If a commonly used net 5 of nylon is used, the distance between the netting tube 4 and the plate 2 needs only be about 1 mm.

5

According to a preferred embodiment the netting tube 4 is, at the front edge 7 provided with an outwardly protruding bead 8 that causes the net 5 to be stretched when it is pulled across the bead 8. Hereby a further tightening of the net 5 is obtained when it is pulled through the netting tube 4, as will be described below.

10

A pull device is provided for pulling a tree to be netted through the supply opening 1 and the netting tube 4. The pulling device comprises two gripper claws 9, each of which being securely attached to a rotatable tube 10 via a lever 11. On each lever 11 a pull bar 12 is pivotally mounted that is, at its opposite end, connected to a hydraulic cylinder 13 via a connector element 14. When the hydraulic cylinder 13 is activated, this construction causes the gripper claws 9 to first be pulled towards each other, optionally around the cut-off end of a tree, following which the entire pull device will be displaced to the right in Figures 1 and 2.

15

20

A cutter device 15 is provided immediately after the netting tube 4, said cutter device 15 comprising, in the embodiment shown, two rotatably mounted and partially overlapping cutter blades 16 that efficiently cut the net 5 off when they are conveyed downwards through an empty net 5 after a tree has been pulled through the device. Underneath the cutter blades 16, two conical rollers 17,18 are mounted that have between them a narrow slot. These rollers 17,18 rest against the netted tree as it leaves the netting tube 4, and the moment the top of the tree has travelled past the rollers and there remains only net 5, the cutter device drops downwards due to its weight, the net 5 penetrating upwards between the rollers 17 and 18, and the cutter blades 16 cutting off the net 5.

25

30

Preferably the cutter device is rotatably mounted about an axis parallel with the longitudinal axis of the netting tube, which is not, however, shown in further detail.

5 A cutter device configured in this manner is of course not restricted to use in connection with a device for the netting of trees according to the present invention, but it may just as well be useful in connection with other devices for the netting of trees.

10 Finally, a conveyor belt 19 is provided that is able to transport the netted tree away from the netting device as such.

In the starting position the device for the netting of trees is adjusted as shown in Figure 2, ie with the front end of the net 5 within the netting tube 4 and the
15 gripper jaws 9 also within the netting tube 4, they being preferably located at the inner face thereof. The cut-off end of a tree to be netted is now conveyed into the supply opening 1 and further into the netting tube 4, where it is enclosed by the net 5, whose end is loosely suspended within the netting tube 4. Then the hydraulic cylinder 13 is activated whereby the gripper jaws 9
20 are caused to engage with the cut-off end of the tree as explained above. When the gripper jaws 9 encounter sufficient resistance to further penetration into the cut-off end, the continued pull of the hydraulic cylinder 13 causes the tree to be pulled through the supply opening 1 and further through the netting tube 4, while the net 5 is pulled along between the tree and the inner face of
25 the netting tube 4. This stage of the netting procedure is shown schematically in Figure 3.

The pull device is able to pull the entire tree through the netting tube 4, but preferably the pull device stops when the thickest portion of the tree has
30 been pulled through, since it is possible to pull the remainder of the tree through by use of less force. Hereby the device according to the invention can be made significantly shorter than the known devices where a pull device pulls the entire tree through the funnel-shaped tube and the cylindrical tube.

When the thickest portion of the tree has been pulled through the netting tube 4, the netted portion drops onto the conveyor belt 19 that contributes with sufficient force to pull the remainder of the tree through the netting tube 4. If it is a case of particularly thick trees that yield extra resistance to being pulled through, a second conveyor belt may be provided above the conveyor belt 19, whereby it is possible to sandwich the tree between the two conveyor belts, thereby generating more friction between the conveyor belts and the tree. This additional conveyor belt may be vertically displaceable, which means that it is able to engage with trees of varying thicknesses.

10

Preferably, the rate of the conveyor belt 19 corresponds to the rate of the pull device whereby the conveyor belt 19 cooperates with the pull device when the tree drops thereon. However, the conveyor belt 19 may be configured such that it runs at an increased rate, eg 2.5 times faster, when the pull device has let go of the cut-off end of the tree and is moved back to its starting position, whereby the tree is removed from the netting tube 4 more quickly.

15

As mentioned previously the netting tube 4 is, in the preferred embodiment, provided, at the front edge 7, with an outwardly protruding bead 8 that causes the net 5 to be stretched when pulled across the bead 8. Preferably the bead 8 has an outer diameter that corresponds essentially to the maximum diameter of the net sleeving 5, whereby additional resistance against the net 5 being pulled over the edge 7 is generated, with the result that the net 5 within the netting tube 4 is further tightened in the longitudinal direction when a tree along with the net 5 is pulled through the netting tube 4. Hereby tight netting of the tree is accomplished.

20

25

The shown and described device for the netting of trees is provided with a hydraulic pull device for pulling trees through the device. However, there is nothing to prevent the use of other kinds of pull devices, eg a mechanical device, or to altogether omit same and pull the trees through the device manually.

30

The shown and described device can be constructed as a separate unit or it may be constructed for mounting on eg a tractor or other forestry machinery. Likewise, it may be combined with other units, such as eg a palleting unit to which the conveyor belt may convey the netted trees.

5

Finally the netting tube can be configured as a replaceable cassette, which means that it can readily be replaced when the net on the first netting tube has been used up. Optionally, a winding device can be mounted instead of the netting tube, whereby the same device can also be used for tying trees.

10

Claims

1. A device for the netting of trees, which device comprises a supply opening (1) and a device for the application of a net sleeving (5) around a tree when the latter is conveyed through the device, **characterised in** that the device for the application of a net sleeving (5) around a tree is separated from the supply opening (1) and comprises a netting tube (4) on the outside of which the net (5) is located, the end of the net (5) being bent around that end (7) of the netting tube (4) that faces towards the supply opening (1) and extends into the netting tube (4).
2. A device according to claim 1, **characterised in** that the netting tube (4) has an inner dimension that corresponds essentially to the dimension of the narrow end of the supply opening (1).
3. A device according to claim 1 or 2, **characterised in** that the netting tube (4) is, at the end (7) that faces towards the supply opening (1), provided with an outwardly oriented bead (8), whose outer diameter corresponds essentially to the largest possible stretched dimension of the net sleeving (5).
4. A device according to any one of claims 1-3, **characterised in** that a pull device is provided for pulling a tree through the device, said pull device comprising at least one gripper jaw (9) that is able to seize around the cut-off end of the tree within the netting tube (4) and that can be displaced through the netting tube (4).
5. A device according to claim 4, **characterised in** that the pull device comprises a drive mechanism that, when a force is applied, first ensures that the gripper jaw (9) engages with the cut-off end of the tree, following which it shifts the gripper jaw (9) along with the tree through the netting tube (4).
6. A device according to claim 5, **characterised in** that the drive mechanism comprises a hydraulic cylinder (13).

7. A device according to any one of claims 1-6, **characterised in** that a cutter device is provided for cutting off the net (5) when a tree has been pulled through the device.
- 5 8. A device according to claim 7, **characterised in** that the cutter device comprises two rotatably mounted and partially overlapping cutter blades (16).
9. A device according to claim 8, **characterised in** that the cutter device is mounted rotatably about a shaft parallel with the netting tube (4), and that it is
10 provided with conical rollers (17,18) that rest on the netted tree, a slot being provided between the rollers (17,18), said slot permitting an empty net (5) to pass through said rollers (17,18) whereby the cutter device is allowed to drop and cut off the net (5).
- 15 10. A device according to any one of claims 1-9, **characterised in** that a conveyor belt (19) is provided after that end of the netting tube (4) that faces away from the supply opening (1), which conveyor belt (19) is configured for conveying the tree away from the netting tube (4).
- 20 11. A device according to claim 10, **characterised in** that the conveyor belt (19) is configured to operate at a rate that corresponds to the rate of movement of the pull device away from the netting tube (4).
12. A device according to claim 11, **characterised in** that the rate of the
25 conveyor belt (19) is increased, preferably by 2.5 times, when the pull device is conveyed towards the netting tube (4).
13. A method for the netting of trees, which method comprises the following steps:
- 30 - locating a tree at the wide end of a supply opening (1);
- displacing the tree through the supply opening (1);
- applying a net sleeving (5) around the tree;
- cutting off the net (5),

characterised in that the net (5) is applied to the tree within a netting tube (4) arranged immediately after the supply opening (1).

5 14. A method according to claim 13, **characterised in** that the major part of the net (5) is located exteriorly on the netting tube (4), the end facing towards the supply opening (1) being bent around the edge (7) of the netting tube (4) and during the netting displaced through the netting tube (4) along with the tree, while more net (5) is drawn beyond the edge (7) of the netting tube (4).

10

15. A method according to claim 13 or 14, **characterised in** that a pull device engages around the cut-off end of the tree inside the netting tube (4) and pulls it there through.

15

16. A method according to claim 15, **characterised in** that the pull device pulls the tree through the netting tube (4) only until the thickest portion of the netted tree has passed through the netting tube (4), following which it is pulled further by use of less force.

20

17. A method according to claim 16, **characterised in** that at least one conveyor belt (19) pulls the tree further when the thickest portion of the tree has passed through the netting tube (4).

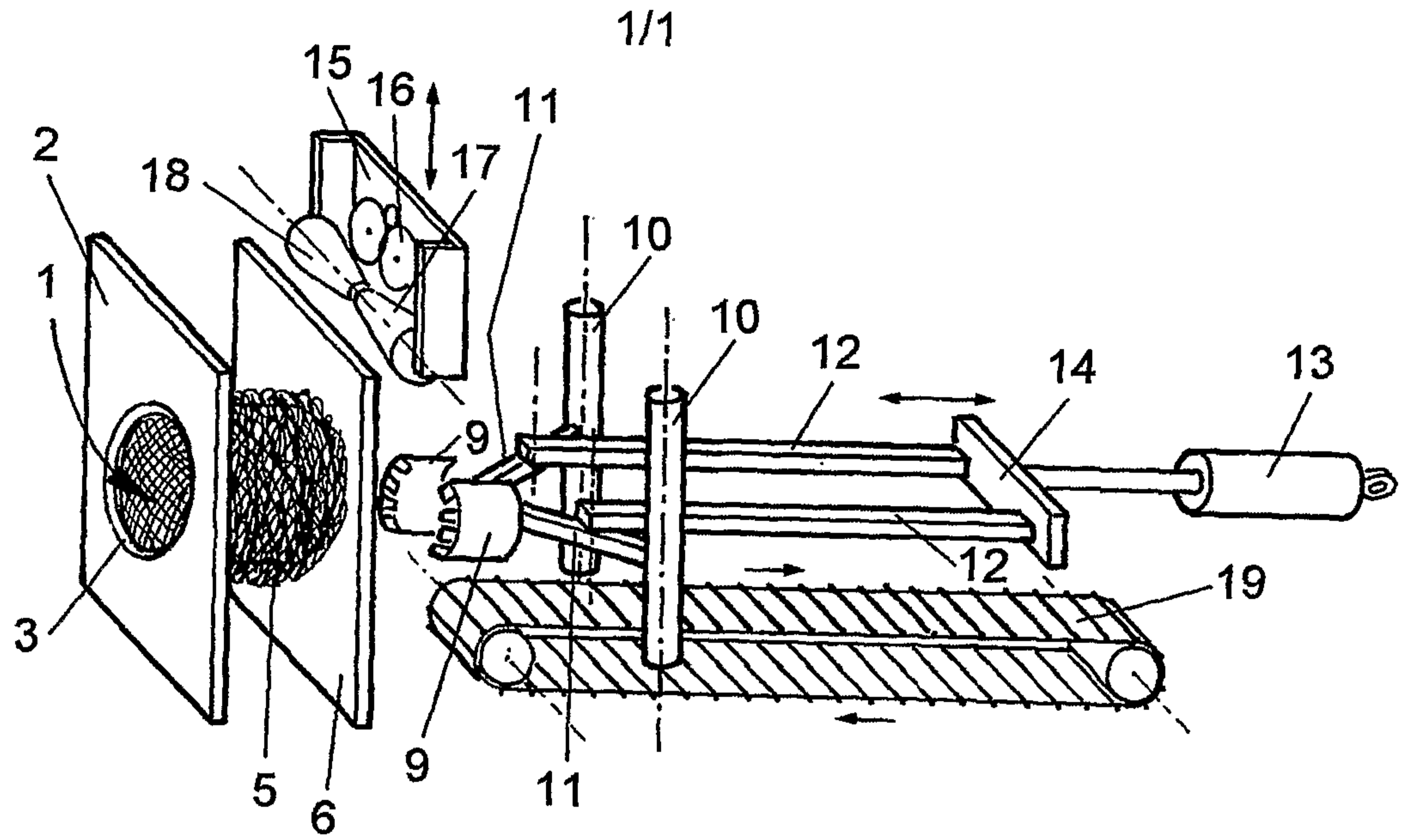

Fig. 1

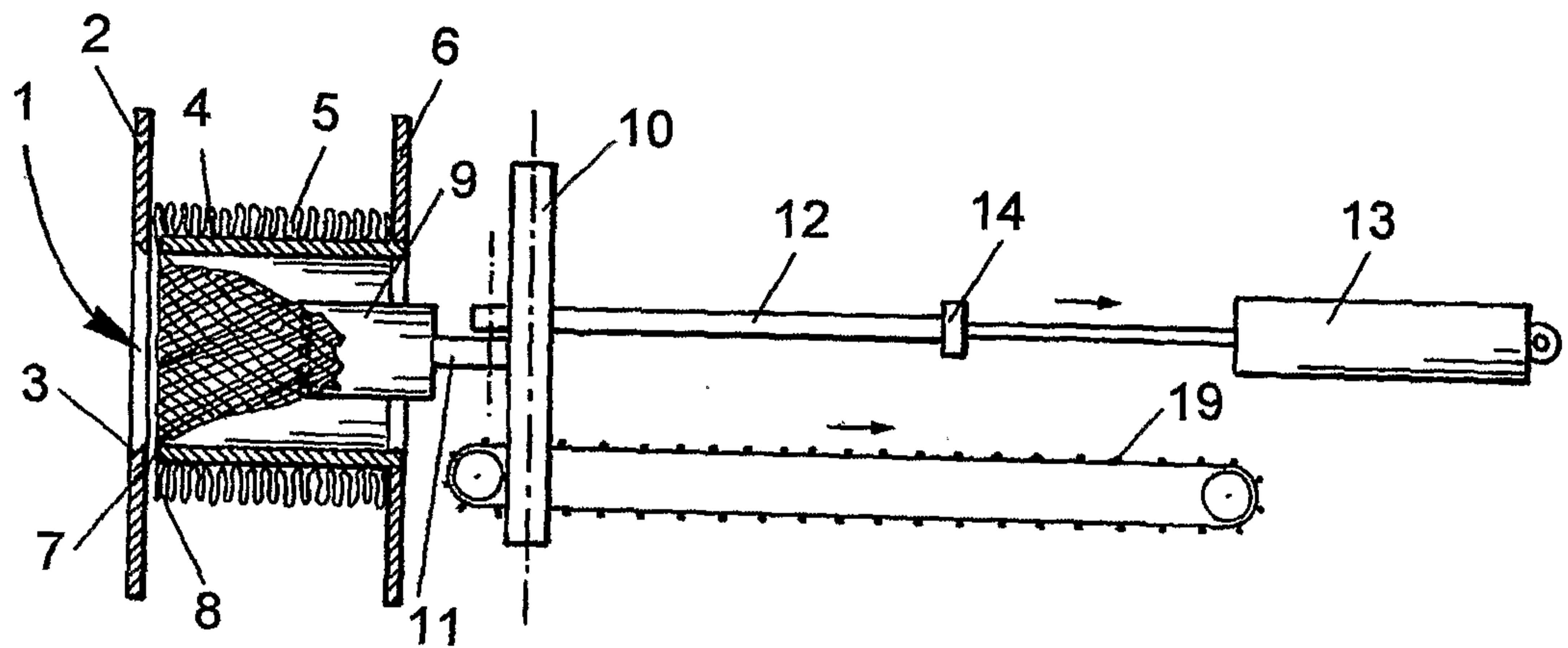

Fig. 2

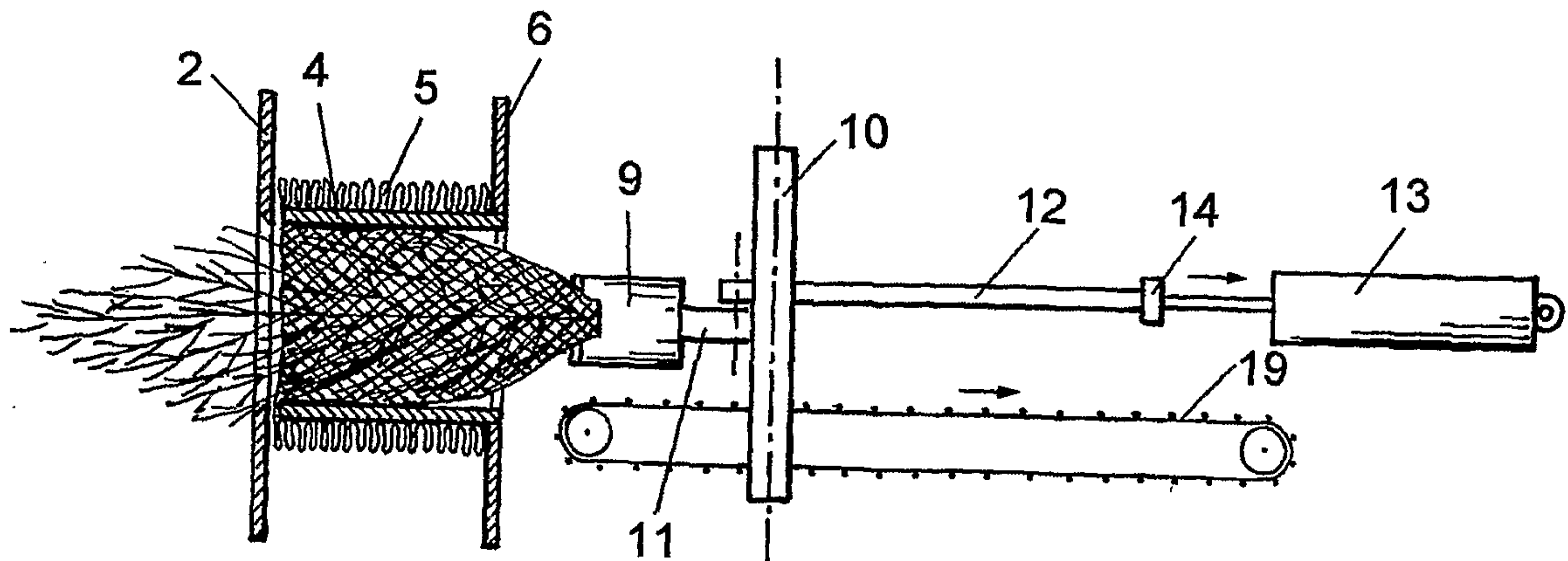

Fig. 3

