

J. M. FOSTER & G. E. LOCKWOOD.
High-Pressure Gas-Regulators.

No. 210,314.

Patented Nov. 26, 1878.

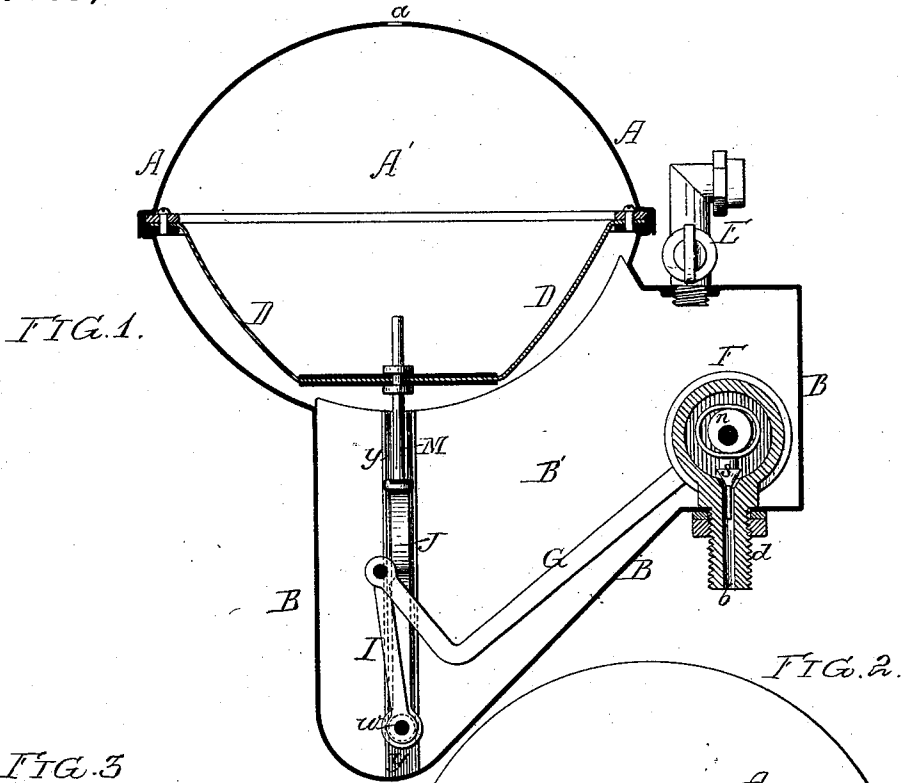

FIG. 1.

FIG. 2.

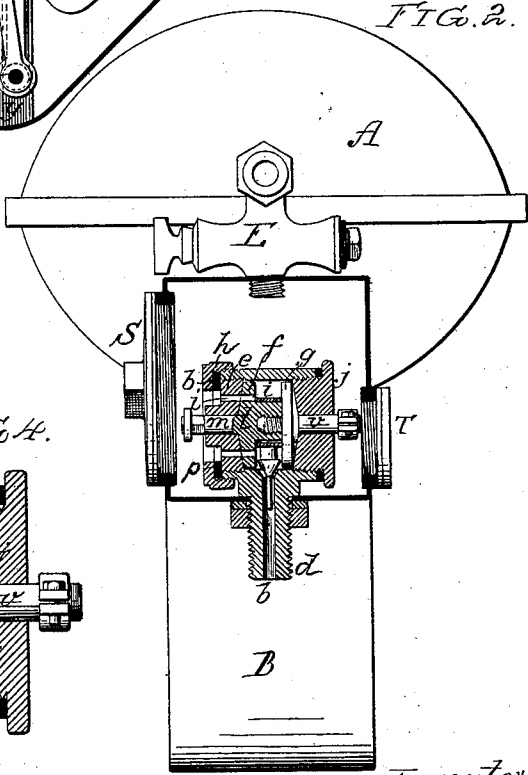

FIG. 3.

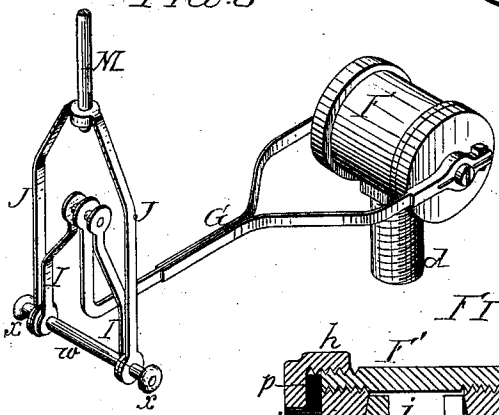
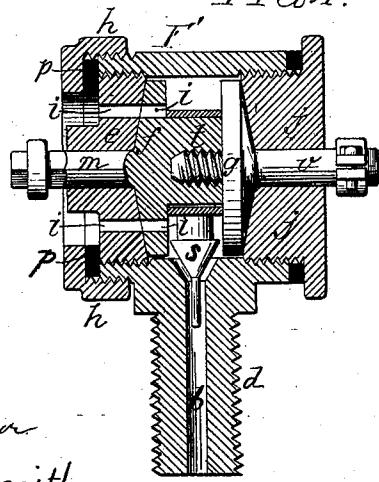

FIG. 4.



Witnesses,
John M. Deemer
Henry Smith

Inventors,
John M. Foster
and
George E. Lockwood
by their Attorneys
Houston and Co.

UNITED STATES PATENT OFFICE.

JOHN M. FOSTER AND GEORGE E. LOCKWOOD, OF PHILADELPHIA, PENNSYLVANIA, ASSIGNORS OF ONE-THIRD THEIR RIGHT TO CHARLES E. MORGAN, OF SAME PLACE.

IMPROVEMENT IN HIGH-PRESSURE GAS-REGULATORS.

Specification forming part of Letters Patent No. 210,314, dated November 26, 1878; application filed September 9, 1878.

To all whom it may concern:

Be it known that we, JOHN M. FOSTER and GEORGE E. LOCKWOOD, of Philadelphia, Pennsylvania, have invented a new and useful Improvement in High-Pressure Gas-Regulators, of which the following is a specification:

Our invention relates to a certain improvement in devices for regulating the pressure of gas as it passes from a reservoir to the burners, the object of our invention being to so construct the device that it is especially applicable for use in connection with the illuminating apparatus of railway-cars, &c., in which the gas is maintained in the reservoir under heavy pressure. This object we attain in the following manner, reference being had to the accompanying drawing, in which—

Figure 1 is a longitudinal section of our improved regulator for high-pressure gas; Fig. 2, an end view of the same, partly in section; and Figs. 3 and 4, detached views of part of the apparatus.

The casing of the apparatus comprises the double convex portion A and the extension B, the interior of the casing being separated into two chambers, A' and B', by a flexible diaphragm, D, the edge of which is secured to a suitable flange on the interior of the upper portion, A, of the casing. The chamber A' communicates with the atmosphere through an opening, a, while gas is admitted to the chamber B', as described hereinafter, and is discharged therefrom through the valved pipe E, which supplies the burners.

At one end of the chamber B' is a casing, F, the interior of which communicates through a passage, b, in a stem, d, with the pipe leading to the gas-reservoir. One end of the casing F is closed by a ring, e, the inner face of which forms a seat for a disk-valve, f, both valve and seat being furnished with ports i, the opening or closing of which is effected by the partial rotation of the valve f. The valve f has a stem, m, which projects through the central opening of the ring e; and on the inner face of the valve is formed an eccentric, n, which is embraced by a sleeve attached to or form-

ing part of the stem of a conical valve, s, the latter being adapted to a seat formed at the upper end of the passage b.

To a threaded opening in the eccentric n is adapted a threaded projection, t, on the inner face of a disk, g, the outer face of which is adapted to a seat formed on the inside of a screw-plug, j, which closes one end of the casing F, a stem, v, on the disk g extending through a central opening in said plug j.

The object of employing the disk g is to balance the pressure exerted by the gas on the valve f; and the object of connecting the said disk to the valve by a threaded projection is to permit the lateral adjustment of the valve and disk in respect to each other after the ring e and plug j have been screwed into place, so that the valve and disk may be firmly seated against the ring and plug.

The disk g and plug j may have ports formed in them in the same manner as the valve f and ring e, if desired.

To prevent the escape of gas around the ring e, a packing-ring, p, is firmly pressed by means of a screw-cap, h, against the end of the casing F and the outer face of the ring.

The outer end of the stem m of the valve f is reduced to a square or angular section, and is adapted to an opening of similar shape in one of the arms of a forked rod, G, the other arm of which embraces the end of the stem v, and is split and provided with an adjusting-screw, whereby it may be clamped to or released from the said stem, as desired.

The end of the rod G is bent upward and pivoted to the upper ends of two arms, I, hung at the lower ends to a rod, w, which is carried by the forked frame J, the latter being secured at the top to a rod, M, attached to the diaphragm D. At each end of the rod w is a button, x, these buttons being adapted to internal guides y, formed on or attached to the opposite sides of the extension B of the casing. In one side of the latter, at a point adjacent to the valve-casing F, is formed an opening, to which is adapted a screw-plug, S, and in the opposite side of the casing is a smaller opening, to which is adapted a screw-plug, T, the

object of these plugs being to permit access to the valve-casing F without necessitating the removal of the diaphragm D.

The operation of the device is as follows: When the parts are in the position shown in Fig. 1, the ports of the valve *f* are in line with those of the ring *e*, and gas can freely enter the chamber B'. As soon as the pressure of gas in this chamber exceeds the weight of the diaphragm D the latter rises, thus, through the medium of the devices described, operating the valve *f* and closing the ports *i* to such an extent that the amount of gas which is permitted to pass through the same is just sufficient to maintain in the chamber B' a pressure which will prevent the descent of the diaphragm, the latter being weighted to such an extent that the gas will be supplied to the burners at the proper pressure.

In case of an undue decrease of pressure in the chamber B', the diaphragm will descend so as to open the valve *f* to an extent sufficient to restore the pressure to its normal degree.

In the event of a sudden or violent increase of pressure in the chamber B', the upward movement of the diaphragm will cause such a movement of the valve *f* as not only to close the ports *i*, but, through the medium of the eccentric *n*, to force the valve *s* down onto its seat, thus effectually cutting off the flow of gas.

The object of connecting the stem *v* of the disk *g* to the arm of the rod G by a friction-clutch is to permit the turning of said stem, so as to properly adjust the disk *g* after the rod G has been fitted into place.

Although we have shown and described a peculiar form of valve, we do not desire to be limited to that particular form, as various constructions of valves having ports to be

opened and closed by the movement of a suitable plug or slide can be used in carrying out our invention.

Our invention is distinct from that class of pressure-regulators in which a valve connected directly to a diaphragm is adapted to an opening in a partition, through which opening the gas has to pass in order to escape, as such a device would be worthless if used in connection with gas under heavy pressure.

We claim as our invention—

1. A pressure-regulator in which a casing having an outlet to the burners is combined with a valve for admitting gas to said casing, a diaphragm exposed to the pressure of gas therein, and devices whereby the diaphragm is caused to effect the opening and closing of the ports of the valve, as set forth.

2. The combination of the diaphragm and the valve with the rod M, the frame J, the guided rod *w*, the arms I, and the rod G, as specified.

3. The combination of the valve *f* and its eccentric *n* with the valve *s*, as set forth.

4. The combination of the valve *f* with the adjustable disk *g*, as set forth.

5. The combination of the valve *f* and its stem *m*, with angular end, the disk *g* and its round stem *v*, and the rod G, one arm of which is adapted to the angular end of the stem *m*, while the other arm has a friction-clutch adapted to the stem *v*, as specified.

In testimony whereof we have signed our names to this specification in the presence of two subscribing witnesses.

JOHN M. FOSTER.

GEORGE E. LOCKWOOD.

Witnesses:

HARRY A. CRAWFORD,
HARRY SMITH.