

(19) **DANMARK**

(10) **DK/EP 3370620 T3**



(12) **Oversættelse af
europæisk patentskrift**

Patent- og
Varemærkestyrelsen

-
- (51) Int.Cl.: **A 61 B 6/10 (2006.01)** **G 21 F 3/00 (2006.01)**
- (45) Oversættelsen bekendtgjort den: **2020-04-14**
- (80) Dato for Den Europæiske Patentmyndigheds bekendtgørelse om meddelelse af patentet: **2020-01-08**
- (86) Europæisk ansøgning nr.: **16806256.0**
- (86) Europæisk indleveringsdag: **2016-11-07**
- (87) Den europæiske ansøgnings publiceringsdag: **2018-09-12**
- (86) International ansøgning nr.: **FR2016052881**
- (87) Internationalt publikationsnr.: **WO2017077259**
- (30) Prioritet: **2015-11-05 FR 1560606**
- (84) Designerede stater: **AL AT BE BG CH CY CZ DE DK EE ES FI FR GB GR HR HU IE IS IT LI LT LU LV MC MK MT NL NO PL PT RO RS SE SI SK SM TR**
- (73) Patenthaver: **Arcita, 973 Rue de la Castelle, 34070 Montpellier, Frankrig**
- (72) Opfinder: **VALADE, Frédéric, 15 Rue Four des Flammes, 34000 Montpellier, Frankrig**
COURTAIS, Hugues, 227 Rue du Pioch de Boutonnet, 34090 Montpellier, Frankrig
- (74) Fuldmægtig i Danmark: **Dennemeyer & Associates S.A, P.O. Box 700425, DE-81304 Munich, Tyskland**
- (54) Benævnelse: **SKÆRM TIL STRÅLINGSBESKYTTELSE**
- (56) Fremdragne publikationer:
WO-A2-2009/156660
JP-A- 2013 007 640
JP-U- S5 757 811
US-A1- 2005 173 658

RADIATION PROTECTION SCREEN

The present invention relates to a radiation protection screen.

Typically, a radiation protection screen is used to separate a person from an element emitting ionising rays, and to protect this person from these rays.

For this purpose, a radiation protection screen comprises a panel coated with a radiation protection sheet (typically a lead sheet).

However, the rigidity of the screen comes only from the panel, and nothing can be fixed thereto so as not to perforate the radiation protection sheet. In addition, in the case of a mobile screen, there is no radiation protection at the level of the wheels, the height of which is generally equal to approximately 15 cm.

Documents US 2005/173658 A1, WO 2009/156660 A2, JP 2013 007640 A and JP S57 57811 U disclose radiation protection screens according to the prior art comprising in particular two main faces and a frame which stiffens the screen and which carries two panels.

The invention solves the aforementioned problems, and in particular allows the fixing of an object to the screen without altering the radiation protection sheet with a radiation protection screen as defined in claim 1, particular embodiments being defined in the dependent claims.

Other features and advantages of the present invention will appear in the detailed description of two examples given without limitation and illustrated in the appended drawings in which:

- Figure 1 is a perspective view of a first example of a folding screen according to the present invention;
- Figure 2 is a perspective view of the frame of the screen of Figure 1, at the bottom of which frame is fixed a baseboard;
- Figure 3 is a perspective view of a second example of a screen according to the present invention;
- Figure 4 is a perspective view of the frame of the screen of Figure 3, at the bottom of which frame is fixed a baseboard and a base;
- Figure 5 is a vertical sectional view passing through the protective glazing of the screen of Figure 3;
- Figure 6 is a sectional view of the portion of the screen located at the glazing beads;
- Figure 7 is a view in exploded perspective of the screen of Figure 3;

- Figure 8 is a perspective view of a system according to one variant of the invention; and
- Figures 9 and 10 are perspective views of a central screen of a system according to the invention.

Figures 1 and 3 show in perspective two examples of radiation protection screen 1 according to the present invention.

Each radiation protection screen 1 comprises two main faces 2, 3: a front face 2 intended to be on the side of the source emitting ionising rays, and a rear face 3 intended to be on the side of persons to be protected from ionising rays.

The radiation protection screen 1 comprises a frame 4 which stiffens same and which carries a front panel 5 on the side of the front face 2, and a rear panel 6 on the side of the rear face 3. Here, the front panel 5 is a radiation protection panel and the rear panel 6 is a non-radiation protection panel. In the present examples, each radiation protection screen 1 has a height of 2 metres and a width of 0.8 metres, and the distance separating the front face 2 from the rear face 3 is 72 millimetres.

The radiation protection panel 5 is formed by a radiation protection sheet 7 (typically a lead sheet) which is fixed to the frame 4 and a non-radiation protection panel 8 (typically the same panel as the rear panel 6) which is fixed to the radiation protection sheet 7. The thickness of the radiation protection sheet 7 is approximately 1 to 2 millimetres.

The rear non-radiation protection panel 6 and the non-radiation protection panel 8 forming a part of the front radiation protection panel 5 comprise an interior panel and an exterior panel. The interior panel is fixed to the lead sheet 7 (in the case of the radiation protection front panel 5) or to the frame 4 (in the case of the non-radiation protection rear panel 6). The exterior panel covers the interior panel. Typically, the interior panel is a chipboard panel (preferably chipboard having good humidity behaviour) and the thickness thereof is about 12 to 16 millimetres. Typically, the exterior panel is a laminate panel and the thickness thereof is about 1 to 2 millimetres.

The frame 4 is made of 12-tenths stainless steel and is formed by an assembly of profiles 9, 10, 11, 12, 13 which gives solidity and lightness to the radiation protection screen 1 (each profile is made of stainless steel).

In particular, the frame 4 comprises external profiles 9, 10, 11 and internal profiles 12, 13. The panels 5, 6 cover at least the internal profiles 12, 13. Preferably, the internal profiles are arranged between the panels 5, 6.

Each profile 9, 10, 11, 12, 13 has a general U shape, each lateral branch of which carries a panel 5, 6. Here, the width of each lateral branch is approximately 20 millimetres

and the width of the central branch is approximately 50 millimetres.

The assembly of profiles 9, 10, 11, 12, 13 comprises a rectangular exterior framework forming the exterior limits of the radiation protection screen 1. In this case, this exterior framework comprises two vertical profiles 9 and two horizontal profiles 10, 11 connecting the two vertical profiles 9 (an upper horizontal profile 10 arranged near the upper ends of the two vertical profiles 9, and a lower horizontal profile 11 arranged near the lower ends of the two vertical profiles 9).

Here, the vertical profiles 9 of the exterior framework have a U-shape, each lateral branch 14 carrying a wheelbase 15 which is parallel to the central branch 16 and which is directed opposite to the other lateral branch 14. The central branch 16 is arranged on the interior side of the radiation protection screen 1 and, therefore, the edge of the exterior framework is formed by the opening of the U. Each wheelbase 15 has a width of about 10 millimetres.

The assembly of profiles 9, 10, 11, 12, 13 also comprises at least one internal horizontal profile 12 which extends from one to the other of the two vertical profiles 9 of the exterior framework (here, four internal horizontal profiles 12).

In the present examples, the central branch of the U of all the horizontal profiles 10, 11, 12 (comprising those of the exterior framework) is formed by two horizontal walls which are in the extension from one to the other so as to form the major part of the central branch, the two horizontal walls being connected to each other by a central U-shaped connecting segment. The central U-shaped segment comprises a central branch and two lateral branches. The central branch of the central U-shaped connecting segment is parallel to the two horizontal walls which form the major part of the central branch of the horizontal profile 10, 11, 12 in a U. The two lateral branches of the central connecting segment are parallel to each other and with the two lateral branches of the horizontal profile 10, 11, 12 in a U. Each horizontal wall carries at a first end a lateral branch of the horizontal profile 10, 11, 12 in a U which extends in a first direction, and to a second end a lateral branch of the central connecting segment which extends in a second direction opposite to the first direction.

The assembly of profiles 9, 10, 11, 12, 13 also comprises two parallel internal vertical profiles 13 which extend between two adjacent internal horizontal profiles 12. In the present examples, the two internal vertical profiles 13 have a U-shape and have, at each of the longitudinal ends thereof, a connecting wall which is carried by the central branch of the internal vertical profile 13 and which is oriented in the opposite direction to that of the lateral branches of the internal vertical profile 13. The two connecting walls of

the two internal vertical profiles 13 make it possible to fix these two profiles 13 to the two adjacent internal horizontal profiles 12. As a result, the two adjacent internal horizontal profiles 12 and the two internal vertical profiles 13 define a rectangular framework in the frame 4.

Sides 5, 6 (more precisely the interior panels of the sides 5, 6) are fixed to the lateral branches of the profiles of the frame 4 and the edges thereof (more precisely the edges of the interior and exterior panels and of the radiation protection sheet 7 of the sides 5, 6) about the wheelbases 15 of the two vertical profiles 9 of the exterior framework of the frame 4.

The radiation protection screen 1 comprises a radiation protection glazing 17. Typically, this radiation protection glazing 17 is what is termed a leaded glazing. Here it has a thickness of 8.5 millimetres (which corresponds to a thickness equivalent of 2.2 millimetres of lead).

Each panel 5, 6 comprises an opening 18, 19 located at the level of the radiation protection glazing 17. Here, the radiation protection glazing 17 is situated at the level of the two internal vertical profiles 13 and of the two adjacent horizontal profiles 12 (more precisely, the U-shaped openings of these four profiles 12, 13 are oriented towards the edges of the radiation protection glazing 17).

The radiation protection screen comprises two glazing beads 20, 21 (here, made of aluminium) which are arranged at the junction of the radiation protection glazing 17 with the openings 18, 19 of the panels 5, 6 and which, when assembled, form a U-shaped profile the central branch of which is arranged thereagainst and each lateral branch surrounds a panel 5, 6 at the opening 18, 19 thereof.

A first glazing bead 20 has a L-shaped cross-section, a first bar 22 (the one forming the central branch of the U of the two glazing beads 20, 21 assembled) surrounds the internal vertical profiles 13 and the adjacent horizontal profiles 12 and a second bar 23 covers the peripheral edge of the opening 18 of the non-radiation protection rear panel 6. The first glazing bead 20 is fixed, on the one hand, to the two internal vertical profiles 13 and to the two adjacent horizontal profiles 12, and on the other hand to the non-radiation protection rear panel 6.

The second glazing bead 21 is a simple enclosure which covers the peripheral border of the opening 19 of the radiation protection front panel 5. To ensure continuity of the radiation protection at the level of the radiation protection glazing 17, the interior panel of the radiation protection front panel 5 comprises, along the edge of the opening 19 thereof, a groove 24. In this groove 24 are arranged the radiation protection glazing 17

and an additional radiation protection sheet 25 (typically a lead sheet). The additional radiation protection sheet 25 covers the part of the radiation protection glazing 17 arranged in the groove 24. The second glazing bead 21 completely covers the additional radiation protection sheet 25 and the solid part of the interior panel surrounding the groove 24. Therefore, the second glazing bead 21 can be fixed to the radiation protection front panel 5 by screwing without breaking the continuity of the radiation protection (the screws pass through the second glazing bead 21 and the solid part of the lower panel which surrounds the groove 24).

The radiation protection screen 1 comprises a peripheral covering 26 (here, made of aluminium) which forms the edge thereof and the exterior limit thereof. The peripheral covering 26 covers the exterior peripheral edges of the two panels 5, 6 and is fixed to the frame 4.

For each upper and lateral exterior peripheral border, the peripheral covering 26 is a profile 27 having the shape of a U with a central panel 28 and two lateral branches 29, each lateral branch 29 covering the exterior peripheral border of a panel 5, 6, and the central branch 28 forming the edge of the radiation protection screen 1.

For the lower peripheral edge, the peripheral covering 26 is formed by a baseboard 30.

In the first example, the baseboard 30 is adapted to be fixed to a floor so as to make the radiation protection screen 1 fixed.

In the second example, the baseboard 30 is also fixed to wheels 31 so as to make the radiation protection screen 1 mobile. Here, each wheel 31 is pivotally mounted relative to the baseboard 30 along a vertical axis to facilitate the change of orientation of the radiation protection screen 1. From the baseboard 30 is suspended a base 32 (here, made of stainless steel) which surrounds the wheels 31. This base 32 comprises a horizontal upper wall 33 which is connected to the baseboard 30 and to the frame 4, and four vertical side walls 34 which is suspended from the upper wall 33 and which surround the wheels 31. Typically, the side walls 34 extend from the upper wall 33 to a distance close to the floor (about 1 centimetre from the floor). In the second example, the wheels 31 are fixed to the lower face of a fixing plate 35, the upper face of which is fixed to the lower face of the upper wall 33.

In the second example, to ensure radiation protection at the wheels 31, the base 32 comprises a radiation protection film (typically a lead sheet). The radiation protection film of the base 32 and the radiation protection sheet of the radiation protection panel 5 are arranged so as to ensure continuity of the radiation protection. Here, the radiation

protection film extends along the part of the upper wall 33 which extends on the side of the front face 2, and along the side wall 34 which is also located on the side of the front face 2. The radiation protection film is covered by the front part of the upper wall 33 and by the front side wall 34.

Finally, to be able to easily direct the movement of the radiation protection screen 1, it comprises at least one handle 36 (here, two handles 36). In this case, each handle 36 is a hollow handle which is arranged in an orifice 37 produced in the central branch of each profile 27 associated with a lateral exterior peripheral edge of the radiation protection screen 1.

One can also provide full handles 38, for example tubular.

The handles 38 preferably comprise an antibacterial material on the surface thereof. For example, the handles comprise a surface metallised by ferrous or non-ferrous metals and cold hardened.

In addition to the properties thereof which confer rigidity without weighing down the radiation protection screen, the frame 4 also enables a secure fixing of an object to the non-radiation protection rear panel 6. This fixing is done on the basis of at least one profile 9, 10, 11, 12, 13 of the frame 4. The fixed object can thus be a horizontal shelf. To limit the size, the shelf can comprise a first part fixed to the frame 4 and a second part hinged to the first part. In the case of a fixed radiation protection screen 1, the fixed object can be a work surface (which can also be based on other supports).

According to a variant, at least one, preferably two support arms 39 can be fixed to the frame 4 or to the rear panel 6. The support arm 39 can serve as a handle 38.

Furthermore, to avoid a tilting of the mobile radiation protection screen 1 due to the weight of the object which is fixed thereto and the material which rests thereon, the upper wall 33 of the base 32 extends more on the side of the rear face 3.

Finally, the presence of the frame 4 also makes it possible to have a radiation protection screen 1 comprising passages which enable the passing of cables (for example electrical cables) and to have power outlets for electrical equipment (in particular that resting on objects fixed to the non-radiation protection rear panel 6).

In addition, the screen can comprise at least one sticker 40 on one or both sides. The sticker 40 can be used to personalise the screen, affix a mark, or decorate the screen. Preferably, the sticker is antimicrobial.

The disclosure further relates to a system comprising at least two screens coupled or capable of being coupled together, at least one of which is as described above.

Preferably, the system comprises a central screen carrying one or more, preferably

two, side screens. The additional screens make it possible to protect more people, in particular, up to 4 to 5 people with two side screens.

Alternatively, the central screen comprises a base and wheels, and preferably the side screens do not comprise a wheel.

Alternatively, the screens are coupled together by means of at least one hinge. Preferably, the hinge comprises a radiation protection element, or a radiation protection panel comprises an extension covering the hinge.

Preferably, the screen or system comprises a mechanism configured to vary the height of the screen or system from the floor, for example, a rise of a few millimetres makes it easier to move while a lowering so as to be at contact with the floor improves radiation protection.

SKÆRM TIL STRÅLINGSBESKYTTELSE
PATENTKRAV

1. Skærm til strålingsbeskyttelse (1), der dels omfatter to primære overflader (2, 3), og dels et skelet (4), der afstiver skærmen (1), og som bærer et panel på hver side (5, 6), hvor et (5) af panelerne (5, 6) er strålingsbeskyttende, kendetegnet ved, at det omfatter en udvendig beklædning (26), der udgør skærmens (1) flade og dækker de to panelers (5, 6) udvendige kanter, hvor den udvendige beklædning (26) omfatter en sokkel (30), der dækker de to panelers (5, 6) nederste udvendige kant, og hvor soklen (30) er fastgjort på hjul (31), der gør det muligt at flytte på skærmen (1), og som omfatter et fodspark (32), der er fastgjort til soklen (30), og hvor fodsparket (32) omgiver hjulene (31).

2. Skærm til strålingsbeskyttelse (1) ifølge krav 1, kendetegnet ved, at skelettet (4) dannes af en konstruktion af profiler (9, 10, 11, 12, 13).

3. Skærm til strålingsbeskyttelse (1) ifølge krav 2, kendetegnet ved, at hver profil (9, 10, 11, 12, 13) har en generel U-form, hvis tværgående forskallinger hver bærer et panel (5, 6).

4. Skærm til strålingsbeskyttelse (1) ifølge et af kravene 1 til 3, kendetegnet ved, at den omfatter en strålingsbeskyttende rude (17).

5. Skærm til strålingsbeskyttelse (1) ifølge et af kravene 1 til 4, kendetegnet ved, at de to paneler (5, 6) fastholdes parallelt med hinanden af skelettet (4).

6. Skærm til strålingsbeskyttelse ifølge et af kravene 1 til 5, kendetegnet ved, at fodsparket (32) omfatter en øvre, vandret væg (33), der er forbundet til soklen (30) og til skelettet (4), og fire lodrette sidevægge (34), der hænger fra den øvre væg (33), og som omgiver hjulene (31).

7. Skærm til strålingsbeskyttelse ifølge et af kravene 1 til 6, kendetegnet ved, at fodsparket (32) omfatter en strålingsbeskyttende film.

8. Skærm til strålingsbeskyttelse (1) ifølge krav 7, kendetegnet ved, at fodsparkets (32) strålingsbeskyttende film og det strålingsbeskyttende panels (5) strålingsbeskyttende lag er placeret således, at kontinuitet i strålingsbeskyttelsen sikres.

9. Skærm til strålingsbeskyttelse (1) ifølge et af kravene 1 til 8, kendetegnet ved, at der er fastgjort en hylde til skelettet (4) på den side af panelet, der ikke er strålingsbeskyttende (6).

10. Skærm til strålingsbeskyttelse (1) ifølge et af kravene 1 til 9, heraf mindst krav 2, kendetegnet ved, at skelettet (4) omfatter nogle udvendige profiler (9, 10, 11) og nogle indvendige profiler (12, 13), hvor de omtalte paneler (5, 6) dækker mindst de indvendige profiler.

11. System, der omfatter mindst to skærme, der er sammenkoblet eller i stand til at blive sammenkoblet, hvoraf mindst en er ifølge et af kravene 1 til 10.

12. System ifølge det foregående krav, hvori de omtalte paneler er sammenkoblet ved hjælp af mindst et hængsel.

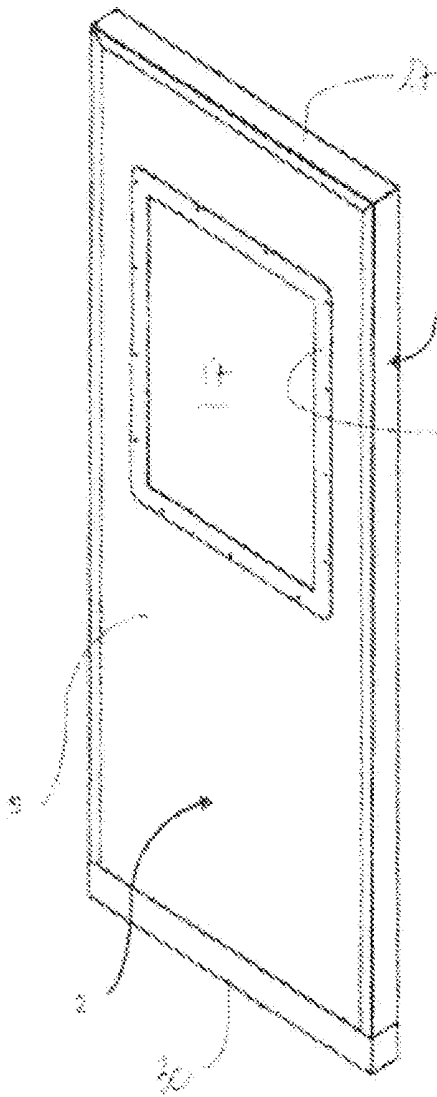

Figure 1

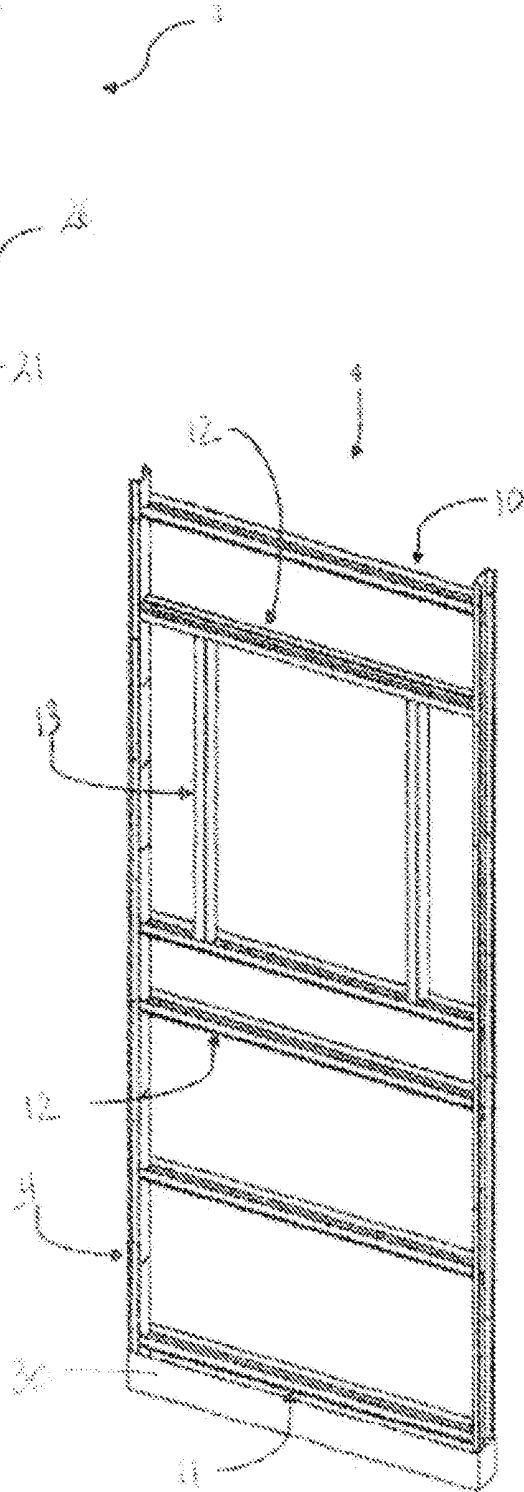

Figure 2

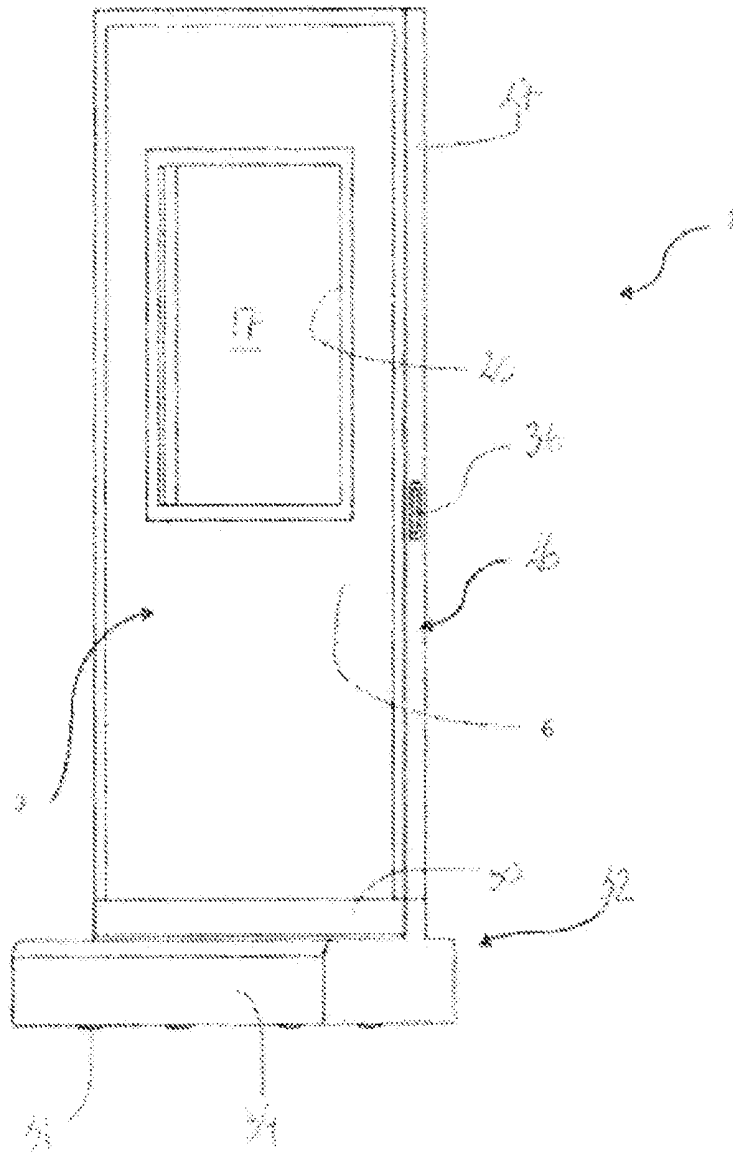

Figure 3

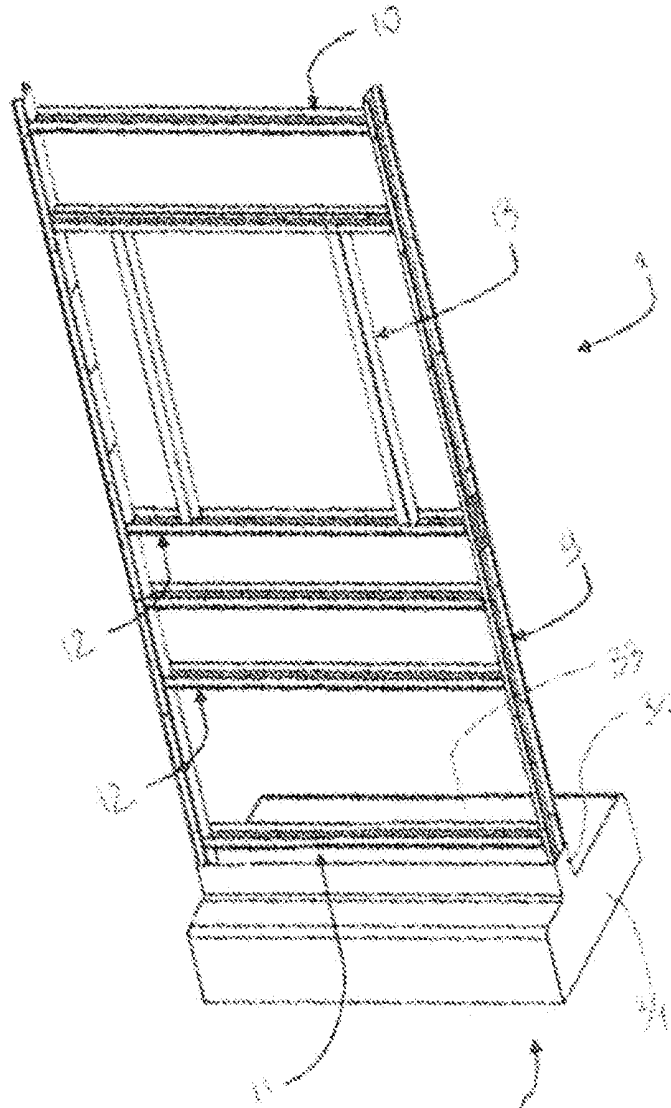
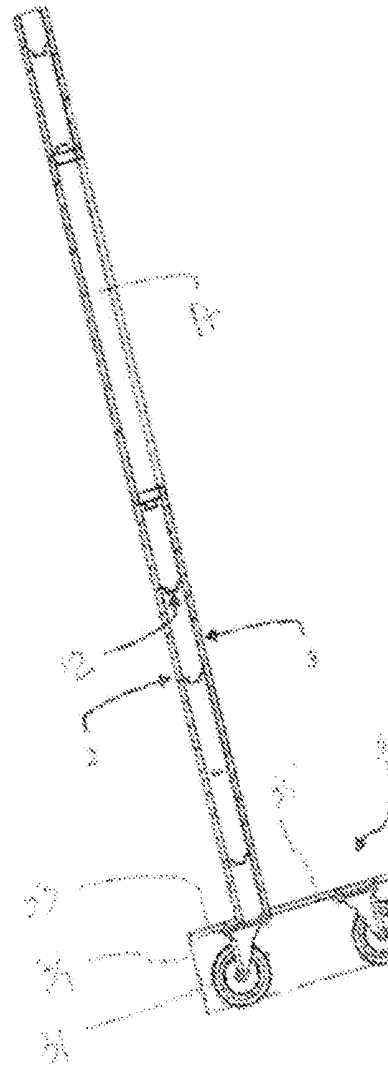

Figure 4

Figure 5



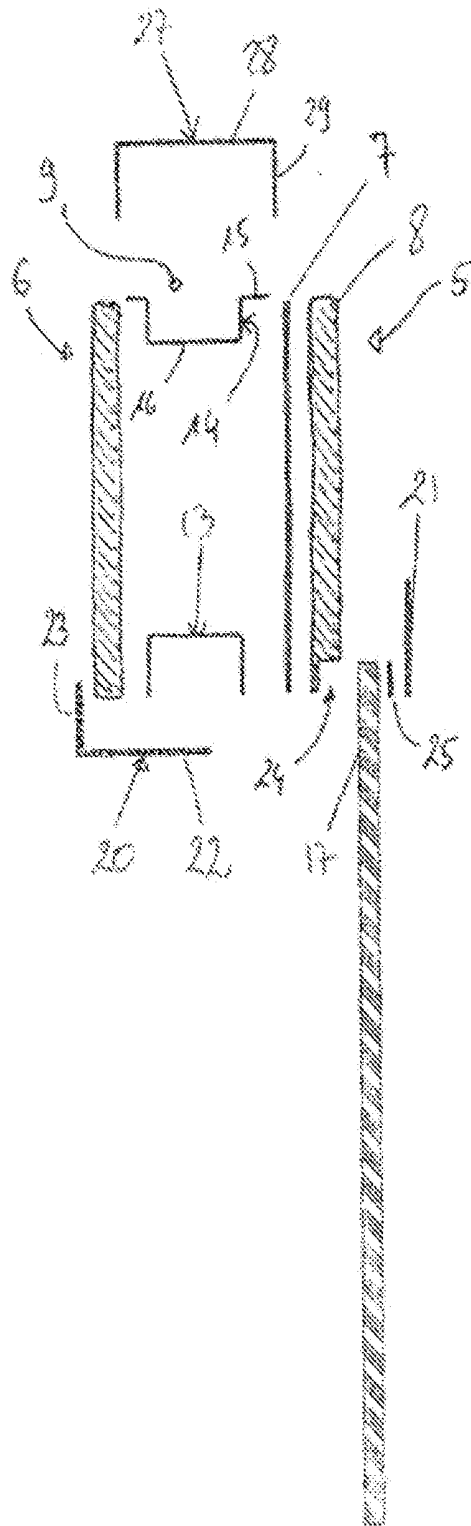

Figure 6

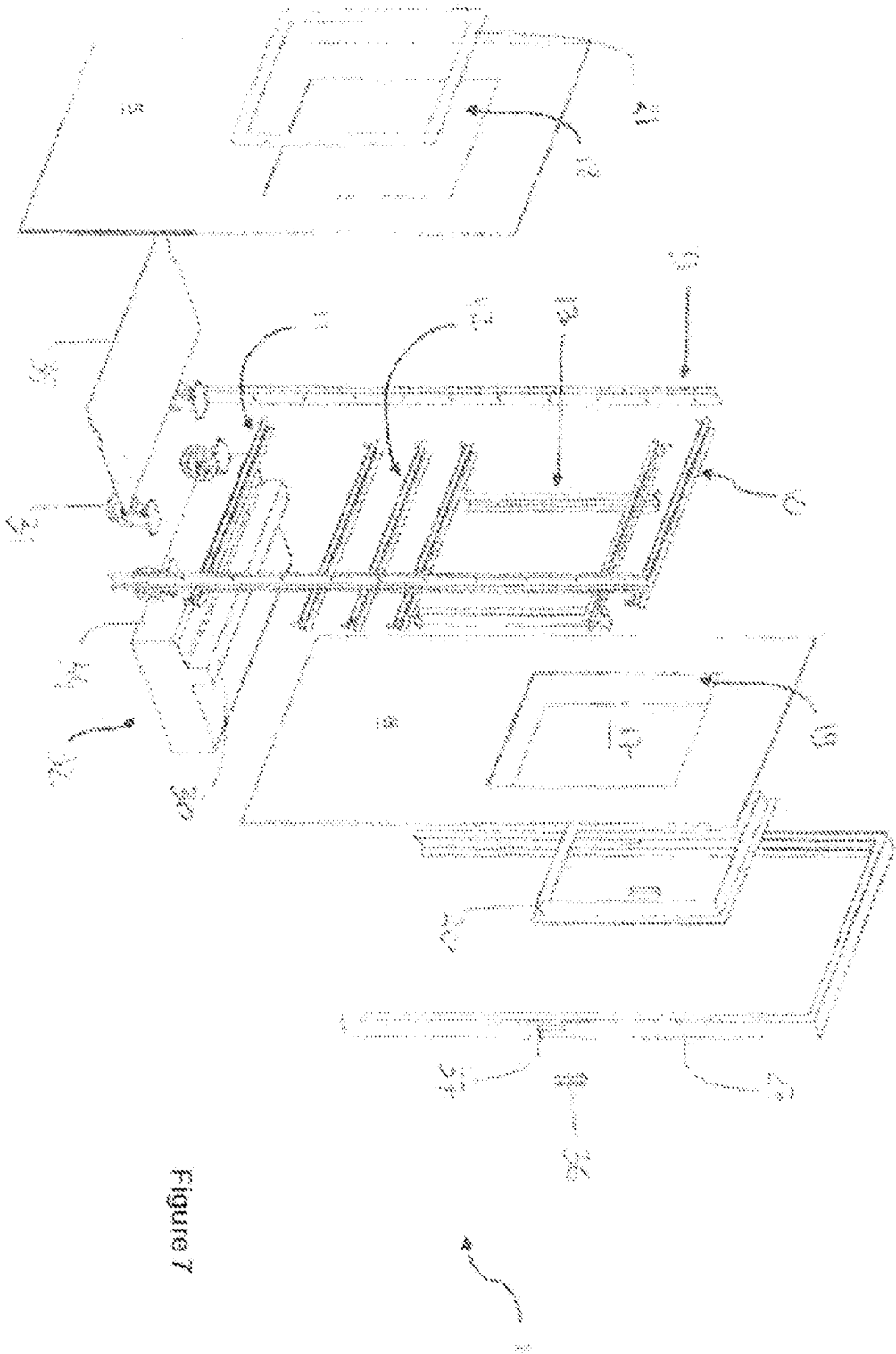

Figure 7

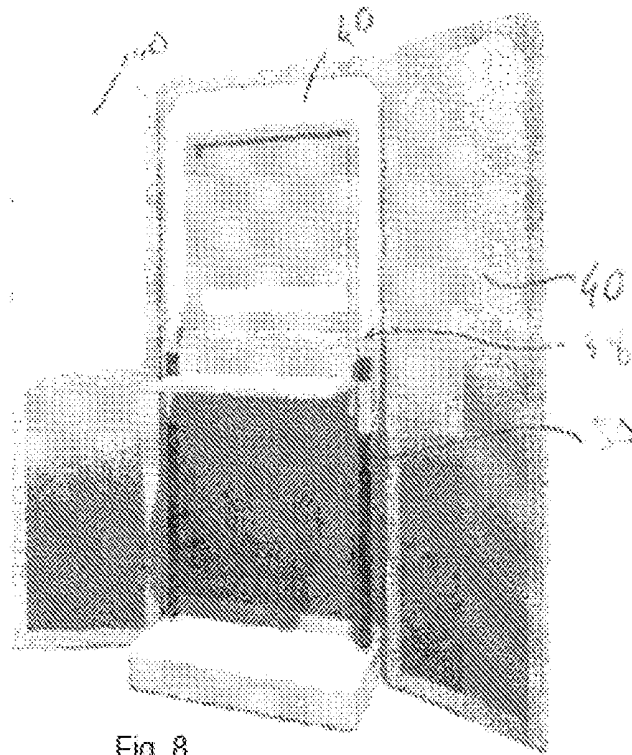

Fig. 8

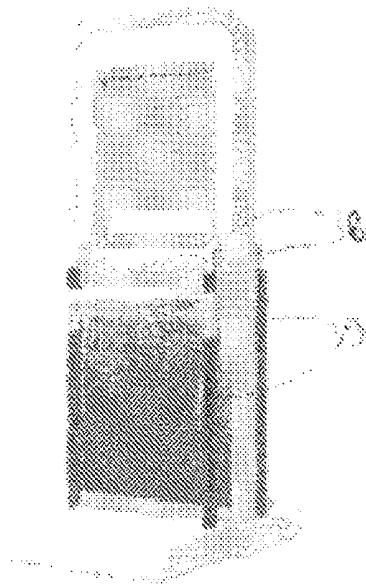

Fig. 9

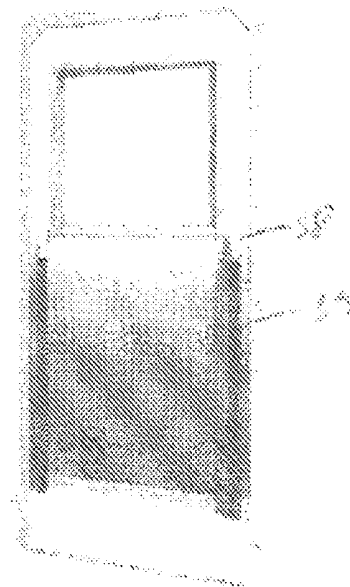

Fig. 10