

(19) World Intellectual Property Organization  
International Bureau



(43) International Publication Date  
1 November 2001 (01.11.2001)

PCT

(10) International Publication Number  
**WO 01/80773 A1**

- (51) International Patent Classification<sup>7</sup>: **A61F 2/00**
- (74) Agents: **BOTH, Georg** et al.; Uexküll & Stolberg, Beselerstr. 4, 22607 Hamburg (DE).
- (21) International Application Number: PCT/EP01/01977
- (81) Designated States (*national*): AE, AG, AL, AM, AT, AU, AZ, BA, BB, BG, BR, BY, BZ, CA, CH, CN, CR, CU, CZ, DE, DK, DM, DZ, EE, ES, FI, GB, GD, GE, GH, GM, HR, HU, ID, IL, IN, IS, JP, KE, KG, KP, KR, KZ, LC, LK, LR, LS, LT, LU, LV, MA, MD, MG, MK, MN, MW, MX, MZ, NO, NZ, PL, PT, RO, RU, SD, SE, SG, SI, SK, SL, TJ, TM, TR, TT, TZ, UA, UG, US, UZ, VN, YU, ZA, ZW.
- (22) International Filing Date: 21 February 2001 (21.02.2001)
- (25) Filing Language: English
- (26) Publication Language: English
- (30) Priority Data:  
100 19 604.7      20 April 2000 (20.04.2000)      DE
- (84) Designated States (*regional*): ARIPO patent (GH, GM, KE, LS, MW, MZ, SD, SL, SZ, TZ, UG, ZW), Eurasian patent (AM, AZ, BY, KG, KZ, MD, RU, TJ, TM), European patent (AT, BE, CH, CY, DE, DK, ES, FI, FR, GB, GR, IE, IT, LU, MC, NL, PT, SE, TR), OAPI patent (BF, BJ, CF, CG, CI, CM, GA, GN, GW, ML, MR, NE, SN, TD, TG).
- (71) Applicant (*for all designated States except US*):  
**ETHICON GMBH** [DE/DE]; Robert-Koch-Str. 1, 22851 Norderstedt (DE).
- (72) Inventors; and
- (75) Inventors/Applicants (*for US only*): **SCHULDT-HEMPE, Barbara** [DE/DE]; Rosenstr. 23, 24576 Bad Bramstedt (DE). **WALTHER, Christoph** [DE/DE]; Dorfstr. 35, 24568 Kattendorf (DE).

**Published:**

— with international search report

*For two-letter codes and other abbreviations, refer to the "Guidance Notes on Codes and Abbreviations" appearing at the beginning of each regular issue of the PCT Gazette.*

(54) Title: IMPLANT

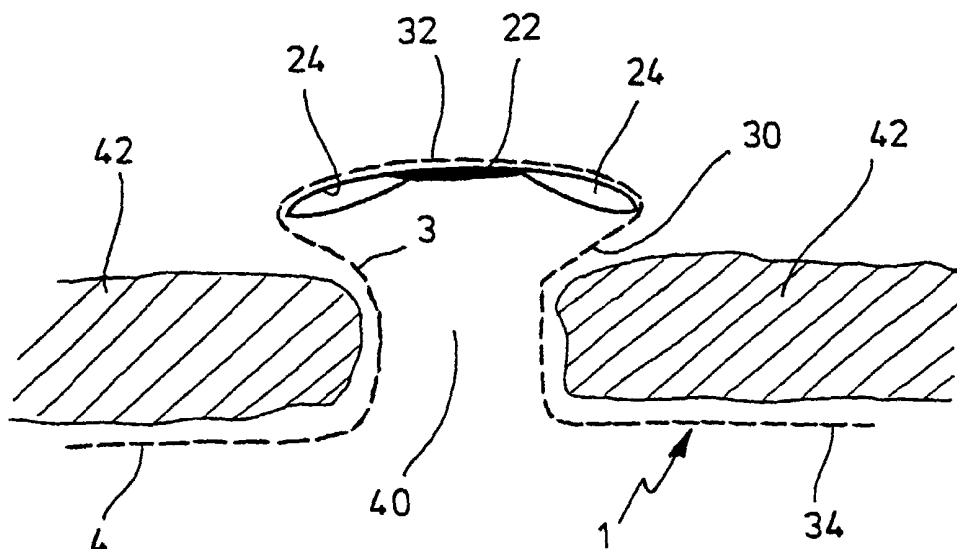

(57) Abstract: An implant (1) has an areal basic structure made from weft-knitted or warp-knitted fabric which has a greater extendability in a central area (3) than in the peripheral area (4) of the implant (1). The basic structure can be deformed in the central area (3) of the implant (1) to produce a projection (30) into the third dimension. The implant (1) preferably has a stiffening structure (22, 24) in the area of the free end (32) of the projection (30). The implant (1) is particularly suitable for treating hernias.



WO 01/80773 A1

### Implant

The invention relates to a surgical implant, the preferred versions of which can be used for treating inguinal hernias.

From WO 92/19162 an implant is known for closing an opening in  
5 a body wall caused by a hernia. The implant consists of an areal component, from the central area of which a type of plug projects. A further areal component is optionally attached to the free end of the plug. This implant can be folded and guided to the area of surgery with the help of a tube. There, the implant  
10 is pushed out of the tube so that the plug fills the opening to be closed while the areal component and where appropriate the optional additional areal component lie laterally against the tissue. Elastic stiffening structures can be provided in order that the implant automatically unfolds after it has been pushed  
15 out of the tube.

A further implant for repairing a hernia in a muscle wall is described in WO 92/13500. This implant contains an areal component from which a protruberance projects which can be closed  
20 with the help of a flap. The protruberance is introduced into the hernia defect and stability is achieved by filling the protruberance with a viscous liquid, which is prevented from leaking by the flap.

25 The previously known implants have a relatively large mass and thus form a relatively large foreign body in the patient, which is not advantageous for the healing process.

It is the object of the invention to provide an implant with a  
30 relatively small mass which can be designed as a safe implant for treating a hernia and can be used without difficulty.

- 2 -

This object is achieved by an implant having the features of claim 1. Advantageous designs of the invention result from the dependent claims.

5 The implant according to the invention has an areal basic structure made from a weft-knitted or warp-knitted fabric. The weft-knitted or warp-knitted fabric of the areal basic structure has a greater extendability in a central area of the implant than in the peripheral area of the implant; the difference in the extendabilities is preferably at least 20% in at least one direction. (The extendability of a sample is inversely proportional to the force necessary for achieving a pre-selected relative change in length of, e.g., 5%.) This greater extendability is preferably achieved by arranging for the mass per surface unit area of the weft-knitted or warp-knitted fabric of the areal basic structure to be smaller in a central area of the implant than in the peripheral area of the implant. The smaller mass per unit area can be achieved by arranging for the mesh density of the weft-knitted or warp-knitted fabric of the areal basic structure to be smaller in a central area of the implant than in the peripheral area of the implant. The weft-knitted or warp-knitted fabric is preferably made in one piece (e.g. using a uniform yarn). Many possibilities are conceivable for the shape of the area of the basic structure with greater extendability; thus this area can be e.g. square, rectangular, cruciform, polygonal, round or also have other shapes.

Thus, the areal basic structure of the implant is more extendable and preferably lighter or less dense in a central area than in the peripheral area, but nevertheless has there a sufficient stability when the amount of material per surface unit is smaller. The term "central area" is to be broadly understood and is not limited to the geometric centre.

35 A particular advantage of the implant manifests itself when, in preferred versions, the basic structure in a central area of the

- 3 -

implant (i.e. in an area with greater extendability of the basic structure) is deformed to produce a projection into the third dimension. The projection is preferably designed as a hollow protruberance and can be broadened mushroom-like in the area of  
5 its free end. Because of the greater extendability of the basic structure in the central area of the implant, the projection can be shaped without overstretching the material of the implant, which would lead to an undesired loss of strength. A comparable projection could not be immediately formed from a uniformly  
10 dense areal basic structure, say a conventional implant mesh; this would rather lead to an undesired wrinkling or to a local overstretching of the material until cracks formed and an associated undesired decrease in strength resulted.

15 The projection of the implant according to the invention is preferably dimensionally stabilized. This can be achieved, e.g., with the help of a heat treatment to which the implant is subjected after forming the projection. (The above-used term "extendability" relates to the basic structure, not to the fi-  
20 nished projection, the material properties of which can be influenced by the shaping and stabilizing process.)

When the implant is provided for the treatment of a hernia, e.g. an inguinal hernia, the projection is introduced into the hernia  
25 defect while the areal basic structure is laid against the body wall structures in the largely flat peripheral area of the implant in the area surrounding the hernia and is optionally attached to it. As the basic structure is manufactured from a weft-knitted or warp-knitted fabric, it is flexible and the projec-  
30 tion also has a sufficient flexibility even after a heat treatment conferring dimensional stability. During the healing process, tissue grows through the meshes of the weft-knitted or warp-knitted fabric. Apart from the flexibility of the implant, a relatively small mass also has a favourable effect.

35

- 4 -

In preferred versions, the implant according to the invention has a stiffening structure in the area of the free end of the projection. This stiffening structure can be annular or disc-like and can preferably be folded. It is advantageous if the  
5 stiffening structure is automatically expandable, from a folded state into an unfolded state, e.g. through the action of a spring or due to the elasticity behaviour of the material used for the stiffening structure.

10 The stiffening structure strengthens the projection. If the projection broadens mushroom-like in the area of its free end and is provided there with the stiffening structure, then a defect in a body tissue can be particularly reliably closed. This is because, in this case, the peripheral area of the basic  
15 structure of the implant lies against one side of the tissue while the projection is secured on the other side of the tissue by the mushroom-like broadening. If the stiffening structure automatically unfolds, the implant can be used in a particularly swift manner which treats the patient gently. To this end, a  
20 tube can be used as an auxiliary means, into which the implant is inserted while folded up. After the tube has been guided to the point of operation, the implant is pushed out of the tube e.g. with the help of a rod so that the projection can penetrate into the opening to be closed and the stiffening structure can  
25 unfold.

An advantageous version, the stiffening structure has an annular or disc-like support from the periphery of which several elastic arcs extend, which are distributed over the circumferen-  
30 ce. The elastic arcs preferably consist of thread material, e.g. polypropylene monofilament. Many designs are conceivable for the support. It can be flat, but also curved like a cap. It is preferably designed as an injection-moulded part, e.g. made from polypropylene, the elastic arcs mentioned being optionally fixed  
35 in their end-areas during the injection-moulding process.

In the light of the intended use, the implant according to the invention can consist completely of non-resorbable material, completely of resorbable material or of both resorbable and non-resorbable material. Multifilaments and monofilaments come into  
5 consideration for the weft-knitted or warp-knitted fabric of the basic structure. A preferred non-resorbable material is polypropylene, a preferred resorbable material is polyglactin 910 (a copolymer made from glycolide and L-lactide in the ratio 9:1). Other polymers and copolymers can also be used. A criterion for  
10 the choice of material is the intended use of the implant, on which e.g. the necessary flexibility and tensile strength and the necessary long-term behaviour in the body depend.

The implant according to the invention is described in more  
15 detail in the following by means of embodiments. The drawings show in

- Figure 1 a threadline representation of a first version of the  
implant according to the invention,  
20
- Figure 2 a schematic representation of the thread guide distribution (upper part) and the pattern template (lower part) of the version according to Figure 1,
- 25 Figure 3 a schematic representation of the thread guide distribution (upper part) and the pattern template (lower part) of a second version of the implant according to the invention,
- 30 Figure 4 a schematic representation of the thread guide distribution, (upper part) and the pattern template (lower part) of a third version of the implant according to the invention,
- 35 Figure 5 in parts (a) to (d) schematic longitudinal sections through forms, with the help of which a projection is

- 6 -

formed from a central area of the implant according to the invention,

5 Figure 6 in part (a) a side view and in part (b) a top view of a stiffening structure for stabilizing a projection formed on the implant according to the invention,

10 Figure 7 a schematic sectional representation of a version of the implant according to the invention with a projection formed thereat which is stabilized by the stiffening structure according to Figure 6, the projection being inserted into a hernia defect, and

15 Figure 8 a loop representation of a weft-knitted product which is suitable for the central area of the basic structure of an implant according to the invention.

A threadline representation of a first version of an implant 1 is shown in Figure 1 in a manner familiar to the person skilled in the art. The implant 1 has a basic structure 2 which consists of a warp-knitted fabric in the embodiment, namely crocheted galloon fabric. In a central area 3 of the basic structure 2, which is cruciform in the embodiment, the mass per surface unit is smaller than in the peripheral area 4 of the basic structure 2. In the embodiment, this difference is achieved by virtue of the fact that the number of partial picks laid in the pillar stitch of the warp-knitted fabric is smaller in the central area 3 than in the peripheral area 4, as is illustrated in Figure 1. The warp-knitted fabric of the basic structure 2 is made in one piece in the embodiment. The peripheral area 4 of the basic structure 2 can extend further than shown in Figure 1.

35 Figure 2 shows the pattern template and the thread guide distribution for the embodiment according to Figure 1 in a manner of representation known to the person skilled in the art. The implant 1 was manufactured as crocheted galloon fabric on a Mül-

- 7 -

ler, Frick (Switzerland) "Raschelina RD3MT3" type crochet galloon machine. Polypropylene threads of 60 den were worked in pillar stitch and polypropylene threads of 140 den in weft. The pattern wefts form the cruciform central area 3 of the implant.

5 The course of the threads results from the pattern template and from the thread guide distribution.

Figure 3 illustrates the pattern template and the thread guide distribution of a second version of the implant, where the central area is numbered 3' and the peripheral area 4'. By using additional thread guides, the resulting contour of the central area 3' is different from that in the version according to Figures 1 and 2. Manufacture took place on the same crochet galloon machine and with the same thread material as in the first version.

10

15

Figure 4 shows the pattern template and the thread guide distribution for a third version of the implant, the central and peripheral areas of which are numbered 3" and 4", respectively.

20 It becomes clear how, with an even greater number of thread guides, a contour of the central area 3" with an even greater number of corners can be achieved, so that the resulting contour here is almost that of a rhombus standing on its tip. The crochet galloon machine and the thread material of the first version were again used.

25

Many designs are conceivable for the shape of the central basic structure of the implant, thus apart from the cruciform and polygonal shapes already considered, also a rectangular or square shape, but also round shapes. The latter can be approximately achieved by polygonal shapes with a large number of corners. In the versions shown above, the areal basic structure of the implant has a smaller mass in the central area considered (which does not have to be arranged around the geometric centre) than

30

35 in the peripheral area. In this way, the basic structure is more extendable in the central area. In principle, however, a greater



extendability can also be achieved in the central area through differences in the type of knit or in the choice of material, even if the mass per surface unit is greater in the central area of the implant than in the peripheral area.

5

In the versions according to Figures 1 to 4, the areal basic structure is made in one piece. It is however also conceivable to manufacture the materials for the central and the peripheral area separately and to insert (e.g. by embroidering, sewing or  
10 gluing) a piece of material for the central area into a recess which is formed in a piece of material for the peripheral area.

In the following table 1, the material and the mesh structure are shown for various warp-knitted fabrics, which are designated  
15 by "fabric 1" to "fabric 10".

Table 1 Material and mesh structure of various warp-knitted fabrics.

20

Fabric	Material and mesh structure
1	3 mil "Pronova" monofilament in warp and weft, hexagonal structure
2	3 mil "Pronova" monofilament in warp and weft, rectangular structure
25 3	3 mil "Pronova" monofilament in warp and weft, hexagonal structure with striped tie-in
4	3 mil "Pronova" monofilament in warp and weft, rectangular structure
5	3 mil "Pronova" monofilament in warp and weft, hexagonal structure
6	60 den polypropylene multifilament in warp and 2x70 den polypropylene multifilament in weft, hexagonal structure

- 7           60 den polypropylene multifilament in warp and 2x70  
den polypropylene multifilament in weft, hexagonal  
structure with striped tie-in
- 8           60 den polypropylene multifilament in warp and 2x70  
den polypropylene multifilament in weft, rectangular  
structure
- 9           60 den polypropylene multifilament in warp and 2x70  
den polypropylene multifilament in weft, honeycomb  
structure
- 10          60 den polypropylene multifilament in warp and 2x70  
den polypropylene multifilament in weft, hexagonal  
structure

5 -----

1 mil = 0.0254 mm

"Pronova" is a trademark for poly(vinylidene fluoride-co-hexa-  
fluoropropylene) used by Ethicon GmbH.

10

The force necessary for a 5% extension in different directions  
of the warp-knitted fabrics in Table 1 is shown in Table 2.  
Furthermore, Table 2 shows the thickness and the mass per unit  
area of these warp-knitted fabrics and additionally the compari-  
15 son data for two conventional implant meshes, which are designa-  
ted A and B in the Table. Mesh A (marketed by Ethicon GmbH under  
the name "Prolene Netz") is prepared from a polypropylene mono-  
filament with a thickness of 6 mil. Mesh B also consists of  
polypropylene monofilaments and is marketed by Atrium Medical  
20 Corporation, 5 Wentworth Drive, Hudson, NH 03051, U.S.A., under  
the name "atrium POLYPROPYLENE MESH".

The force necessary for a 5% extension was determined with the  
help of a "ZWICKI 1120" test apparatus from Zwick GmbH, Ulm, on  
25 samples 60 mm wide and 100 mm long. The gauge length of the  
respective sample measured in longitudinal direction was 25 mm.  
The sample width extending in cross-direction corresponded to  
the 60 mm width of the rubber-coated jaws of the test apparatus.  
An initial force of 0.1 Newtons was built up at a speed of 2  
30 mm/min. The distance between the jaws was then increased at a

test speed of 20 mm/min until a 5% sample extension was achieved. The force occurring in this process was measured and is stated in Table 2 for various directions of the knitted structure of the individual samples.

5

Table 2 Properties of the warp-knitted fabrics from Table 1 and of two previously known implant meshes.

	Fabric	Longitudinal [N]	Transverse [N]	Diagonal [N]	Thickness [mm]	Mass per unit area [g/m <sup>2</sup> ]
10	1	16.46	8.71	9.26	0.29	39.85
15	2	25.66	19.4	18.79	0.36	41.40
	3	20.45	7.37	12.21	0.30	44.40
	4	38.19	5.44	17.39	0.30	38.75
	5	1.35	0.89	3.09	0.26	29.61
	6	24.82	3.28	12.11	0.37	42.01
20	7	47.18	13.33	21.76	0.40	37.29
	8	47.77	1.41	12.80	0.40	32.53
	9	0.99	3.55	5.32	0.29	22.03
10	10	41.62	1.59	4.41	0.25	17.58
	A	125	< 0.5	152.2	0.6	95.2
25	B	130	50	92.9	0.46	92

The structure of the warp-knitted fabric 5 is the same as the knitted structure of the central area 3 of the implant 1 according to Figures 1 and 2. Table 2 shows that the extendability of the warp-knitted fabric 5 is particularly high. The warp-knitted fabric 9 also has a great extendability. The structures of the warp-knitted fabrics 5 and 9 are therefore particularly suitable for the central area of an implant of the type considered here.

The structures of the other warp-knitted fabrics, which have a smaller extendability and generally also a higher mass per unit

35

area, come into consideration in particular for the peripheral area of such an implant. For the peripheral area, however, structures are also conceivable as with the conventional meshes, the extendability of which is generally even smaller.

5

In preferred versions of the implant, the basic structure in the particularly extendable central area is deformed to produce a projection into the third dimension. Figure 7 shows a schematic section through a completely shaped implant 1; various designs  
10 for forms for the development of the projection, however, will be explained first with reference to Figure 5.

Figure 5 shows in parts (a) to (d) four examples of such forms in schematic longitudinal section. In each case a rotationally  
15 symmetrical form 10a, 10b, 10c or 10d is attached to a base plate 12. The respective forms 10a, 10b, 10c or 10d and the base plate 12 are preferably made from metal.

In order to deform the basic structure of an implant, which is  
20 areal after its manufacture, into the third dimension, the basic structure is firstly heated to a temperature which still lies clearly (e.g. at least 10 K) below the (lowest) melting point of the material of which the basic structure consists. The basic structure is then pressed against one of the forms 10a to 10d  
25 (or else a differently designed form) in a central area, while the peripheral area of the basic structure lies against the base plate 12.

At the increased temperature, the material of the basic structure  
30 softens so that a projection in the shape of a hollow protruberance is developed in the basic structure by the form 10a, 10b, 10c or 10d, without the material of the basic structure being overstressed or even tearing as a result of the occurring extensions. During the shaping it proves favourable that the  
35 weft-knitted or warp-knitted fabric, in the zone which is exten-

- 12 -

ded by the form 10a, 10b, 10c or 10d, is be designed beforehand for greater extendability.

A heat treatment is preferably carried out on the implant after  
5 the projection has been formed, in order to stabilize the projection. If the implant (as in the embodiments) is made from polypropylene, then a thermal treatment in the oven at 150°C for 2 hours is particularly suitable.

10 After the projection has been formed and the thermal treatment has ended, the implant maintains its shape with the three-dimensional projection and is flexible both in the peripheral area and in the area of the projection.

15 In Figure 6 an example is shown of a stiffening structure 20 with the help of which the projection can be stabilized in the area of its free end, as is explained in more detail below with the help of Figure 7. In the embodiment, the stiffening structure 20 includes an annular support 22, which is manufactured as  
20 an injection-moulding part made from polypropylene. During the injection-moulding process, elastic arcs 24 are cast into the edge area of the support 22, which in the embodiment are made from polypropylene monofilament. The arcs 24, eight in total, are regularly distributed over the circumference of the support  
25 22, see Figure 6 (b). The support 22 is slightly curved downwards in the manner of a cap so that the arcs 24 also point somewhat downwards in the representation according to Figure 6 (a).

30 The stiffening structure 20 can be folded up or collapsed by pressing the flexible arcs 24 onto the centre of the support 22. If the arcs 24 are released or freed again, they automatically extend to their original shape (or at least largely to their original shape) so that the stiffening structure 20 again adopts  
35 the unfolded state represented in Figure 6.

Figure 7 illustrates an implant 1 with the basic structure according to Figures 1 and 2, where a projection 30 is formed in the central area 3 in the way described above. The warp-knitted fabric has a physiologically acceptable pore size in the area of the projection 30. To form the projection 30, the mushroom-like form 10b was used. The projection 30 is thus broadened mushroom-like in the area of its free end 32. In this area, the stiffening structure 20 described using Figure 6 is inserted into the projection 30. The peripheral area 4 of the basic structure forms the largely flat edge area 34 of the implant 1.

Figure 7 shows how the implant 1 is inserted into a hernia defect 40 which lies between tissue structures 42. Other tissue structures, such as skin or peritoneum, are not included in Figure 7. The mushroom-like broadening of the projection 30, which is stabilized by the stiffening structure 20, preferably comes to rest between the tissue structures 42 and the peritoneum. In order to insert the implant 1 into the hernia defect 40, the implant 1 can be folded and inserted into a tube the outer diameter of which is roughly as large as the hernia defect 40. With the help of this tube, the implant 1 can be guided through the hernia defect 40. When the implant 1 is pushed out of the tube e.g. with the help of a rod, the stiffening structure 20 automatically unfolds and in the process gives the projection 30 the shape represented in Figure 7.

In the versions described up to now, the basic structure of the implant is warp-knitted. Weft-knitted fabrics can also be used, however. Figure 8 shows the mesh representation of a weft-knitted fabric which is suitable for the central area of an implant. This weft-knitted fabric is a combined single-thread knitted fabric 50, which has thread loops of differing sizes. In the embodiment, the material used is polypropylene (60 den for the pillar stitch and 140 den for the weft).

Claims

1. Implant, comprising an areal basic structure (2) made from a weft-knitted or warp-knitted fabric, the weft-knitted or warp-knitted fabric of the areal basic structure (2) having a greater extendability in a central area (3) of the implant (1) than in the peripheral area (4) of the implant (1).  
5
2. Implant according to claim 1, characterized in that the mass per unit area of the weft-knitted or warp-knitted fabric of the areal basic structure (2) is smaller in a central area (3) of the implant (1) than in the peripheral area (4) of the implant (1).  
10
3. Implant according to claim 1 or 2, characterized in that the mesh density of the weft-knitted or warp-knitted fabric of the areal basic structure (2) is lower in a central area (3) of the implant (1) than in the peripheral area (4) of the implant (1).  
15
4. Implant according to one of claims 1 to 3, characterized in that the weft-knitted or warp-knitted fabric is made in one piece.  
20
5. Implant according to one of claims 1 to 4, characterized in that the basic structure (2) is deformed in a central area (3) of the implant (1) to produce a projection (30) into the third dimension.  
25
6. Implant according to claim 5, characterized in that the projection (30) is designed as a hollow protruberance.  
30
7. Implant according to claim 5 or 6, characterized in that the projection (30) is broadened mushroom-like in the area of its free end (32).

- 15 -

8. Implant according to one of claims 5 to 7, characterized in that the projection (30) is dimensionally stabilized.
9. Implant according to one of claims 5 to 8, characterized in that the implant (1) has a stiffening structure (20) in the area of the free end (32) of the projection (30).
10. Implant according to claim 9, characterized in that the stiffening structure (20) is annular or disc-like.
11. Implant according to claim 9 or 10, characterized in that the stiffening structure (20) can be folded.
12. Implant according to claim 11, characterized in that the stiffening structure (20) is expandable automatically from a folded state into an unfolded state.
13. Implant according to claim 12, characterized in that the stiffening structure (20) has an annular or disc-like support (22) from the periphery of which several elastic arcs (24) extend, distributed over the circumference.
14. Implant according to claim 13, characterized in that the elastic arcs (24) consist of thread material, preferably of polypropylene monofilament.
15. Implant according to claim 13 or 14, characterized in that the support (22) is curved in the manner of a cap.
16. Implant according to one of claims 1 to 15, characterized in that the shape of the area (3) of the basic structure (2) with greater extendability is chosen from the following group of shapes: square, rectangular, cruciform (3), polygonal (3', 3''), circular.



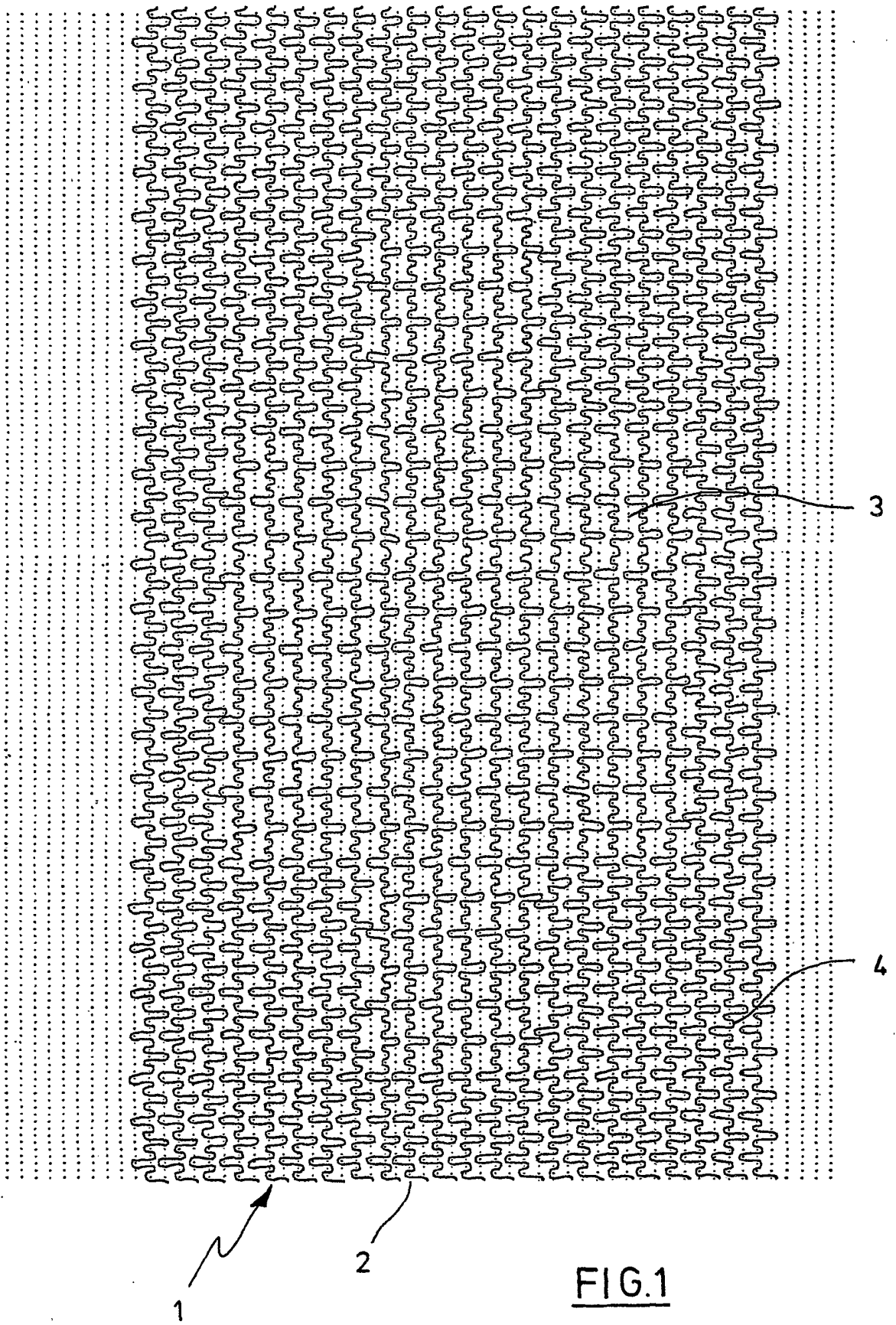

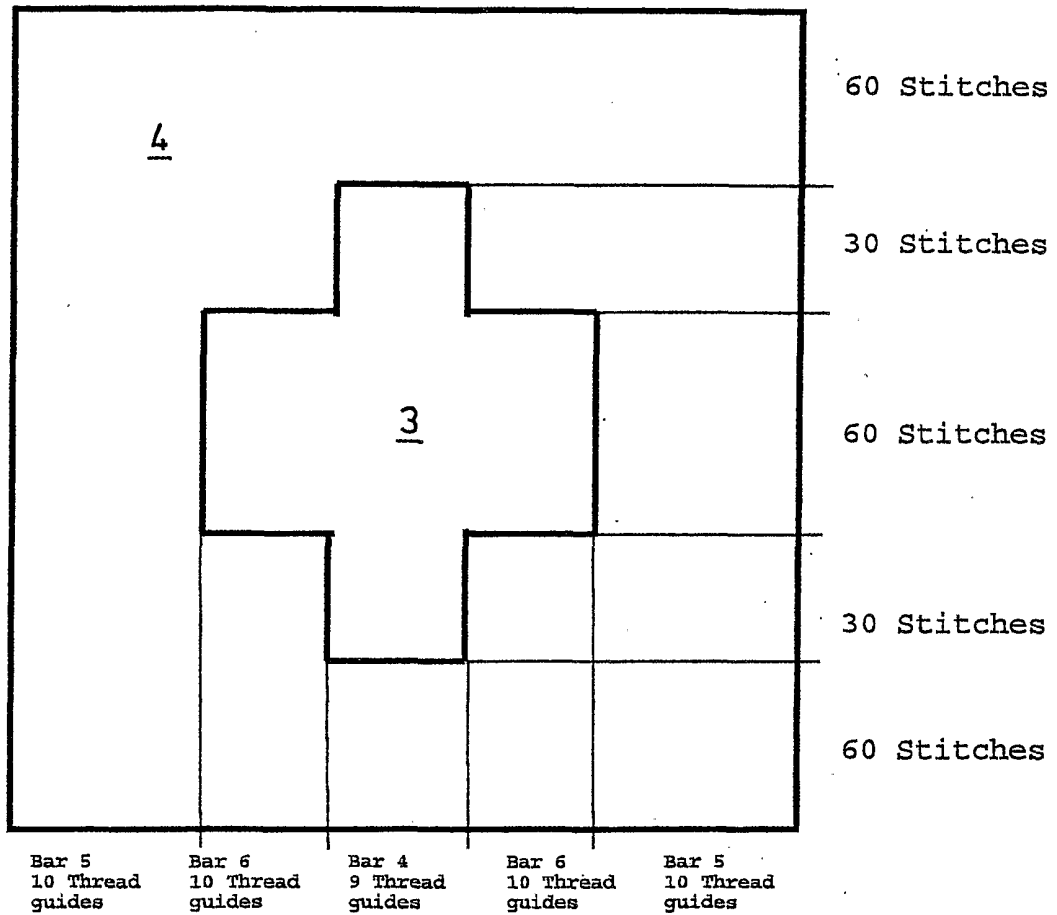

Bar 4			Bar 5	Bar 6		
0	0	0	0	0	0	0
$\frac{4}{2}$	$\frac{4}{2}$	$\frac{4}{2}$	$\frac{4}{2}$	$\frac{4}{2}$	$\frac{4}{2}$	$\frac{4}{2}$
$\frac{6}{2}$	$\frac{4}{2}$	$\frac{6}{2}$	$\frac{6}{2}$	$\frac{6}{2}$	$\frac{4}{2}$	$\frac{6}{2}$
$\frac{4}{2}$	$\frac{6}{2}$	$\frac{4}{2}$	$\frac{4}{2}$	$\frac{4}{2}$	$\frac{6}{2}$	$\frac{4}{2}$
(x10)	2	(x10)	(x40)	(x15)	2	(x15)
	$\frac{4}{2}$				$\frac{4}{2}$	
	$\frac{4}{2}$				$\frac{4}{2}$	
	(x12)				(x6)	

FIG. 2

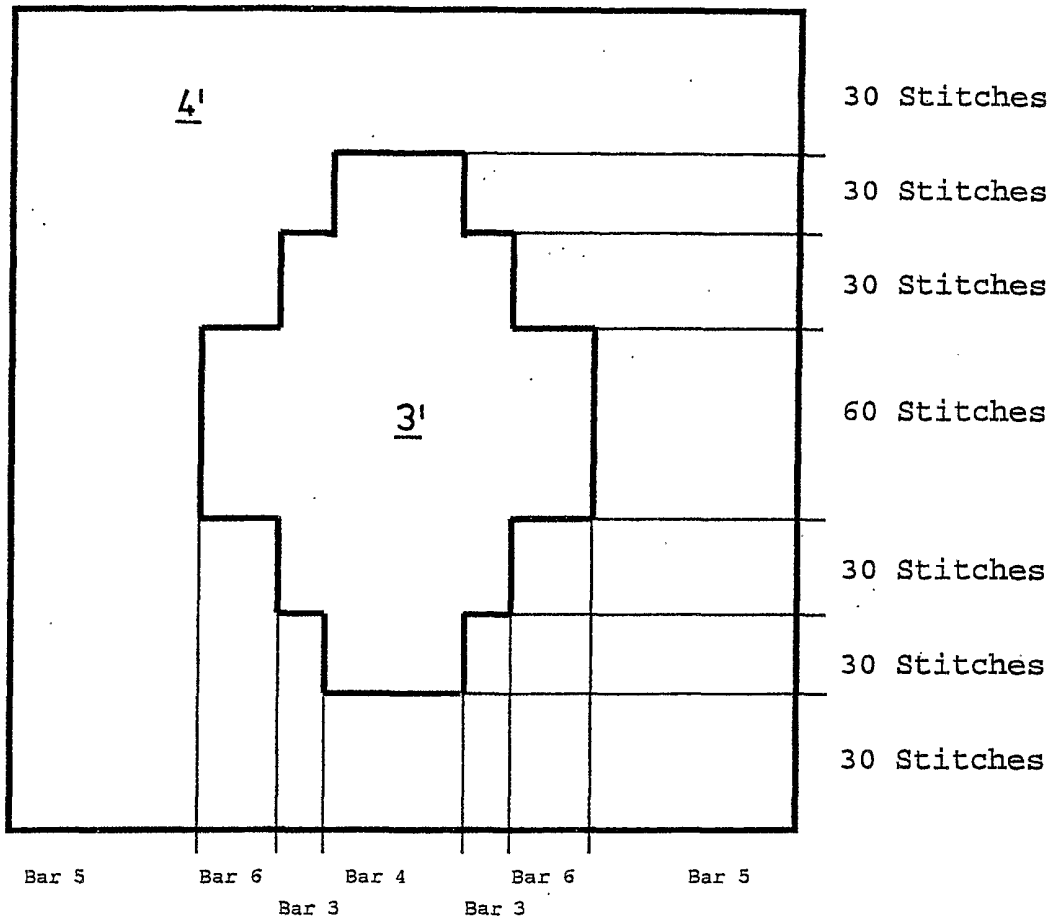

Bar 3 4 Thread guides			Bar 4 10 Thread guides			Bar 5 12 Thread guides			Bar 6 6 Thread guides		
0	0	0	0	0	0	0			0	0	0
$\frac{4}{2}$	$\frac{4}{2}$	$\frac{4}{2}$	$\frac{4}{2}$	$\frac{4}{2}$	$\frac{4}{2}$	$\frac{4}{2}$			$\frac{4}{2}$	$\frac{4}{2}$	$\frac{4}{2}$
$\frac{6}{2}$	$\frac{4}{2}$	$\frac{6}{2}$	$\frac{6}{2}$	$\frac{4}{2}$	$\frac{6}{2}$	$\frac{6}{2}$			$\frac{6}{2}$	$\frac{4}{2}$	$\frac{6}{2}$
$\frac{4}{2}$	$\frac{6}{2}$	$\frac{4}{2}$	$\frac{4}{2}$	$\frac{6}{2}$	$\frac{4}{2}$	$\frac{4}{2}$			$\frac{4}{2}$	$\frac{6}{2}$	$\frac{4}{2}$
(x10)	2	(x10)	(x5)	2	(x5)	(x40)			(x15)	2	(x15)
	$\frac{4}{2}$			$\frac{4}{2}$						$\frac{4}{2}$	
	$\frac{4}{2}$			$\frac{4}{2}$						$\frac{4}{2}$	
	(x12)			(x18)						(x6)	

FIG. 3

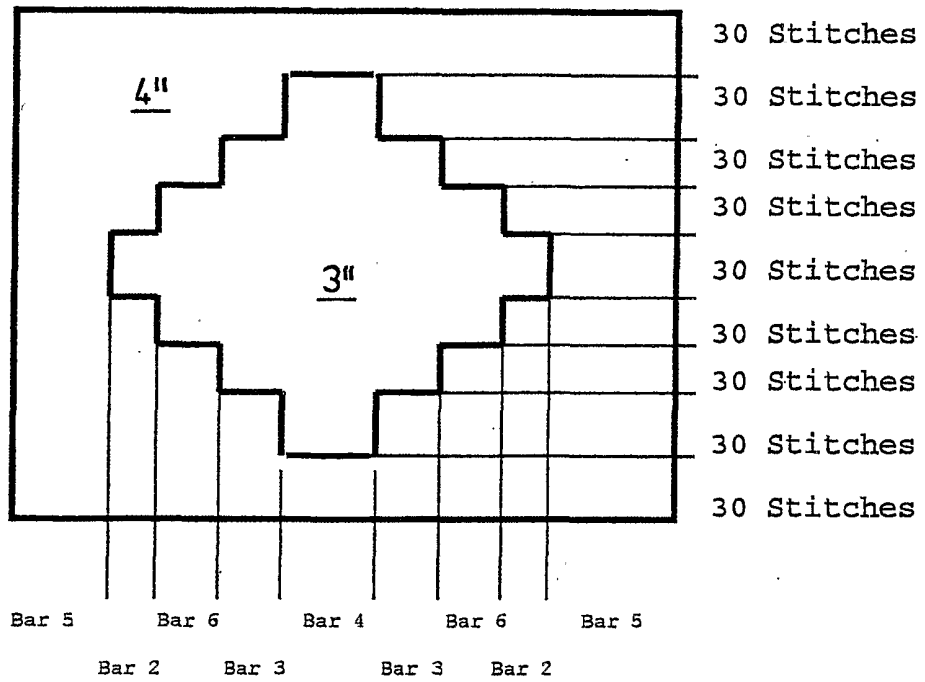

Bar 2 4 Thread guides			Bar 3 6 Thread guides			Bar 4 8 Thread guides			Bar 5 8 Thread guides		Bar 6 6 Thread guides		
0	0	0	0	0	0	0	0	0	0	0	0	0	
$\frac{4}{2}$	$\frac{4}{2}$	$\frac{4}{2}$	$\frac{4}{2}$	$\frac{4}{2}$	$\frac{4}{2}$	$\frac{4}{2}$	$\frac{4}{2}$	$\frac{4}{2}$	$\frac{4}{2}$	$\frac{4}{2}$	$\frac{4}{2}$	$\frac{4}{2}$	
$\frac{6}{2}$	$\frac{4}{2}$	$\frac{6}{2}$	$\frac{6}{2}$	$\frac{4}{2}$	$\frac{6}{2}$	$\frac{6}{2}$	$\frac{4}{2}$	$\frac{6}{2}$	$\frac{6}{2}$	$\frac{6}{2}$	$\frac{4}{2}$	$\frac{6}{2}$	
$\frac{4}{2}$	$\frac{6}{2}$	$\frac{4}{2}$	$\frac{4}{2}$	$\frac{6}{2}$	$\frac{4}{2}$	$\frac{4}{2}$	$\frac{6}{2}$	$\frac{4}{2}$	$\frac{4}{2}$	$\frac{4}{2}$	$\frac{6}{2}$	$\frac{4}{2}$	
(x20)	2	(x20)	(x10)	2	(x10)	(x5)	2	(x5)	$\frac{4}{2}$	$\frac{4}{2}$	$\frac{6}{2}$	$\frac{4}{2}$	
	$\frac{4}{2}$			$\frac{4}{2}$			$\frac{4}{2}$		(x45)	(x15)	2	(x15)	
	$\frac{2}{2}$			$\frac{2}{2}$			$\frac{2}{2}$				$\frac{4}{2}$		
	$\frac{4}{2}$			$\frac{4}{2}$			$\frac{4}{2}$				$\frac{4}{2}$		
	(x3)			(x15)			(x21)				$\frac{4}{2}$		
											(x9)		

FIG. 4

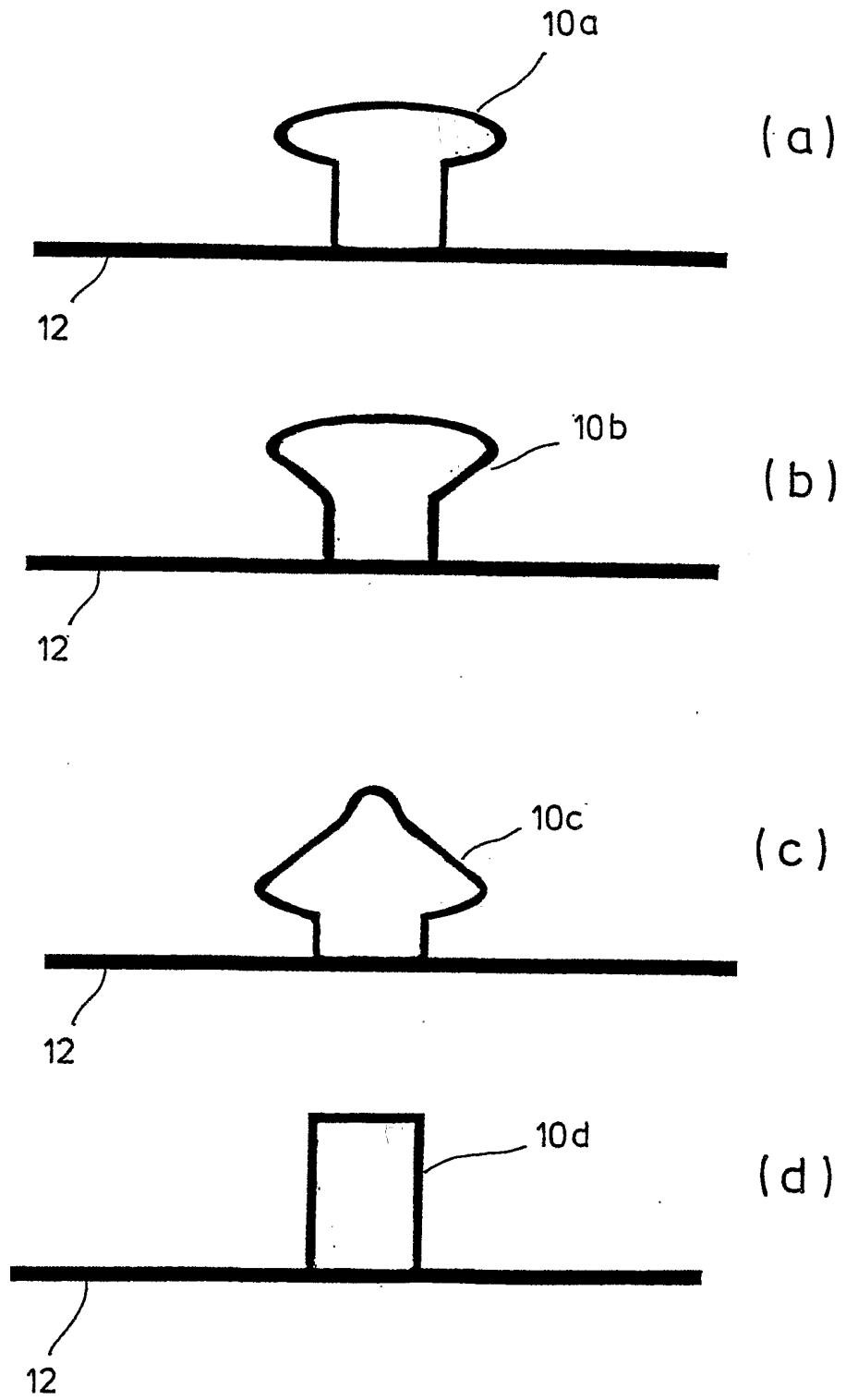

FIG.5

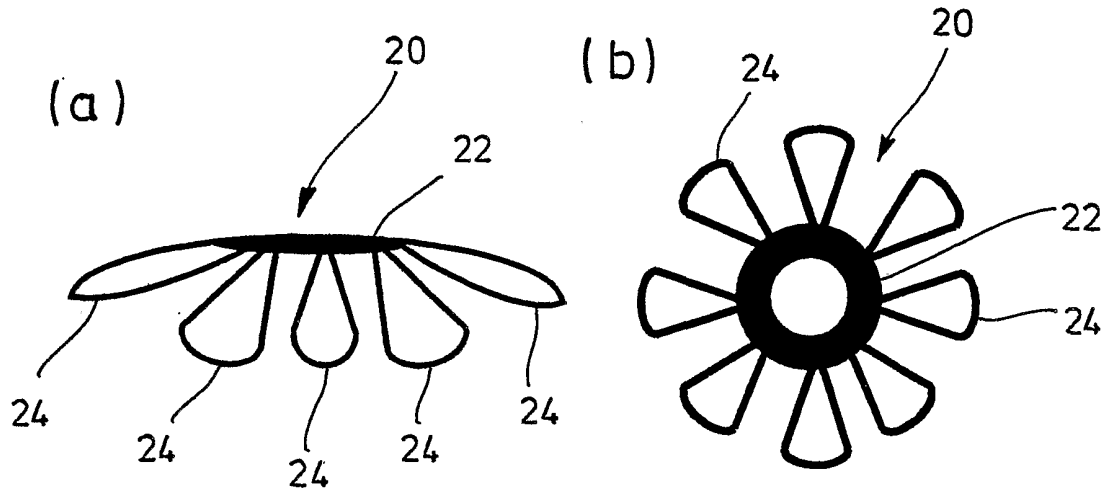

FIG. 6

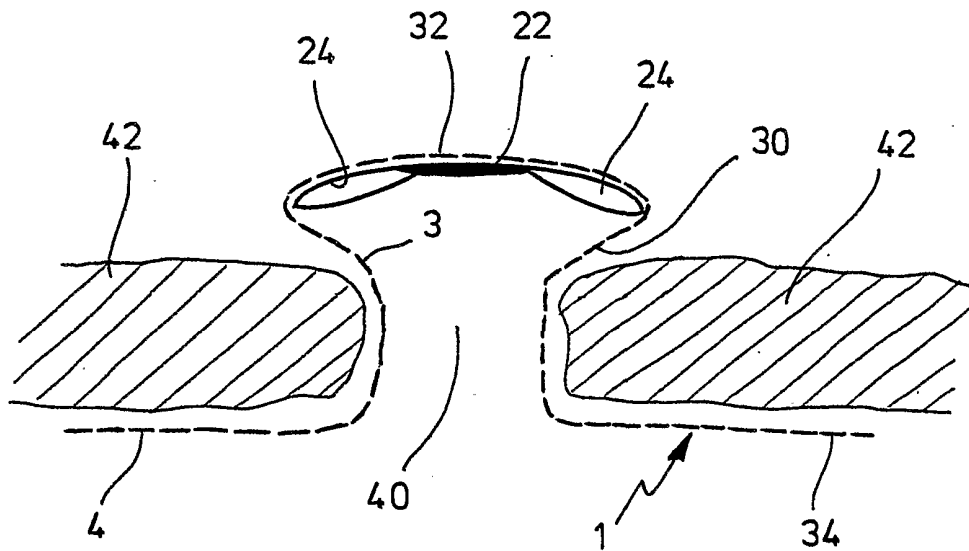
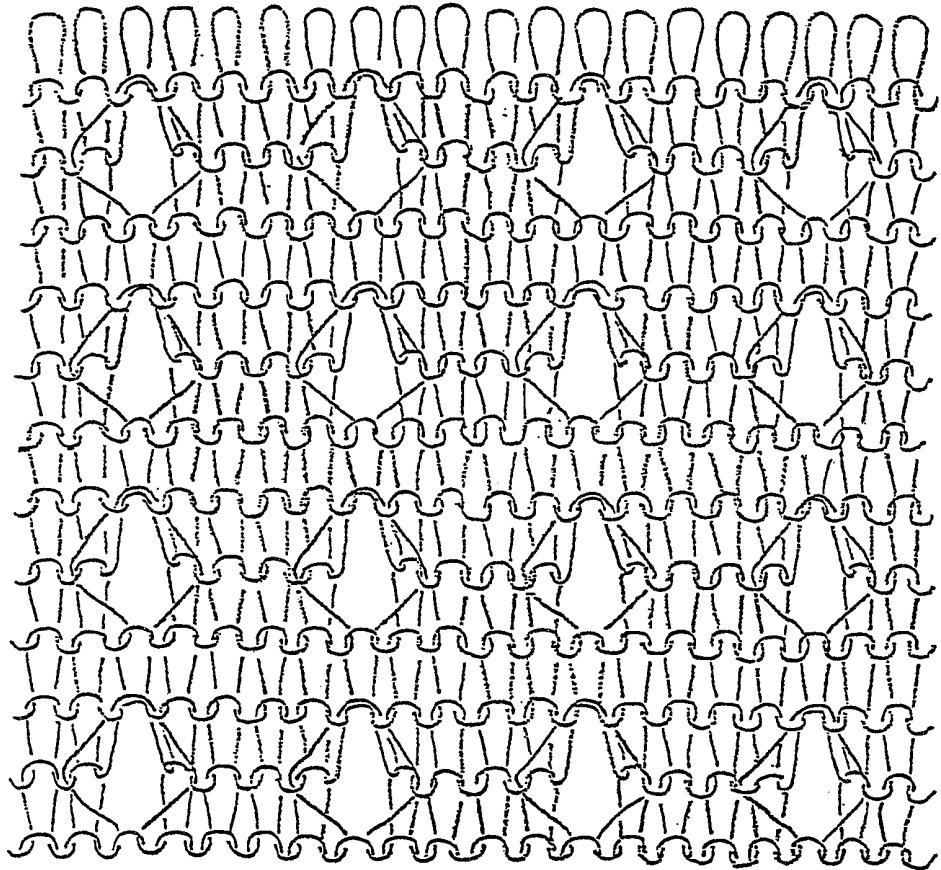

FIG. 7

FIG. 8



50

## INTERNATIONAL SEARCH REPORT

 International Application No  
 PCT/EP 01/01977

<b>A. CLASSIFICATION OF SUBJECT MATTER</b> IPC 7 A61F2/00		
According to International Patent Classification (IPC) or to both national classification and IPC		
<b>B. FIELDS SEARCHED</b>		
Minimum documentation searched (classification system followed by classification symbols) IPC 7 A61F		
Documentation searched other than minimum documentation to the extent that such documents are included in the fields searched		
Electronic data base consulted during the international search (name of data base and, where practical, search terms used) EPO-Internal		
<b>C. DOCUMENTS CONSIDERED TO BE RELEVANT</b>		
Category °	Citation of document, with indication, where appropriate, of the relevant passages	Relevant to claim No.
X	FR 2 769 825 A (COGENT SARL) 23 April 1999 (1999-04-23) figures 1-8 page 6, line 7 -page 8, line 14 page 9, line 1 -page 10, line 15 claims 1-15 ---	1,4,5,16
A	EP 0 888 756 A (HERNIAMESH S R L) 7 January 1999 (1999-01-07) figures 1,2 column 3, line 16 - line 29 column 3, line 40 -column 4, line 3 ---	1
A	US 5 686 090 A (DAHLKE HERMANN ET AL) 11 November 1997 (1997-11-11) figures 2,4,8,10 column 3, line 16 - line 43 column 3, line 61 -column 4, line 45 --- -/--	1
<input checked="" type="checkbox"/> Further documents are listed in the continuation of box C. <input checked="" type="checkbox"/> Patent family members are listed in annex.		
° Special categories of cited documents :		
*A* document defining the general state of the art which is not considered to be of particular relevance *E* earlier document but published on or after the international filing date *L* document which may throw doubts on priority claim(s) or which is cited to establish the publication date of another citation or other special reason (as specified) *O* document referring to an oral disclosure, use, exhibition or other means *P* document published prior to the international filing date but later than the priority date claimed		*T* later document published after the international filing date or priority date and not in conflict with the application but cited to understand the principle or theory underlying the invention *X* document of particular relevance; the claimed invention cannot be considered novel or cannot be considered to involve an inventive step when the document is taken alone *Y* document of particular relevance; the claimed invention cannot be considered to involve an inventive step when the document is combined with one or more other such documents, such combination being obvious to a person skilled in the art. *&* document member of the same patent family
Date of the actual completion of the international search  25 May 2001		Date of mailing of the international search report  01/06/2001
Name and mailing address of the ISA European Patent Office, P.B. 5818 Patentlaan 2 NL - 2280 HV Rijswijk Tel. (+31-70) 340-2040, Tx. 31 651 epo nl, Fax: (+31-70) 340-3016		Authorized officer  Mary, C



## INTERNATIONAL SEARCH REPORT

International Application No  
PCT/EP 01/01977

## C.(Continuation) DOCUMENTS CONSIDERED TO BE RELEVANT

Category *	Citation of document, with indication, where appropriate, of the relevant passages	Relevant to claim No.
A	FR 2 735 015 A (MICROVAL) 13 December 1996 (1996-12-13) page 4, line 19 -page 5, line 12 -----	1
A	US 5 743 917 A (SAXON ALLEN) 28 April 1998 (1998-04-28) figures 2,3 column 7, line 50 - line 57 column 7, line 58 -----	1

## INTERNATIONAL SEARCH REPORT

Information on patent family members

Inter Application No

PCT/EP 01/01977

Patent document cited in search report		Publication date	Patent family member(s)	Publication date
FR 2769825	A	23-04-1999	AU 9453998 A EP 1024764 A WO 9920204 A	10-05-1999 09-08-2000 29-04-1999
EP 0888756	A	07-01-1999	NONE	
US 5686090	A	11-11-1997	AU 666600 B AU 5477194 A BR 9400359 A CA 2114282 A GR 1002613 B JP 7047090 A	15-02-1996 04-08-1994 16-08-1994 29-07-1994 20-02-1997 21-02-1995
FR 2735015	A	13-12-1996	WO 9641588 A	27-12-1996
US 5743917	A	28-04-1998	US 5725577 A	10-03-1998