

(No Model.)

H. J. GUTMAN.
INCANDESCENT LAMP SOCKET.

No. 474,826.

Patented May 17, 1892.

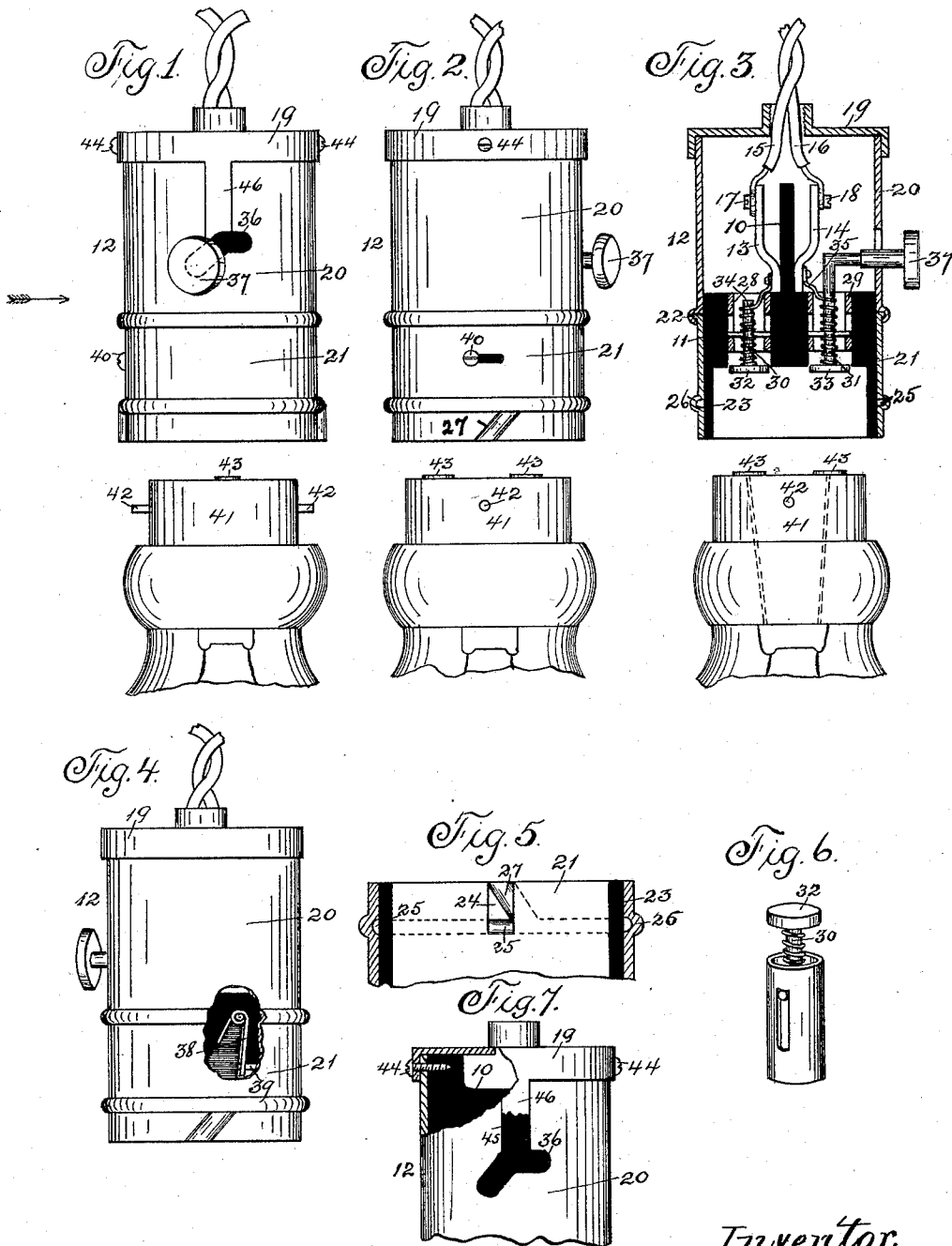

Witnesses
W. P. Smith.
S. G. Green.

Inventor:
Harry J. Gutman,
by Bulkeley & Sweet,
his Attys.

UNITED STATES PATENT OFFICE.

HARRY J. GUTMAN, OF DES MOINES, IOWA.

INCANDESCENT-LAMP SOCKET.

SPECIFICATION forming part of Letters Patent No. 474,826, dated May 17, 1892.

Application filed June 29, 1891. Serial No. 397,763. (No model.)

To all whom it may concern:

Be it known that I, HARRY J. GUTMAN, a citizen of the United States, residing at Des Moines, in the county of Polk and State of Iowa, have invented new and useful Improvements in Incandescent-Lamp Sockets, of which the following is a specification.

My invention has for its object the provision of means by which the lamp may be readily, conveniently, and firmly secured to and held by the socket and also readily detached therefrom.

My invention has for a further object the provision of means by which, after the joinder of the lamp to the socket, the current may be cut on or off by the key without arcing, this result being accomplished by the abrupt and almost instantaneous separation or meeting of the parts, the insulation being so complete and entire as that there is no heating of the parts under excess of current or by long-continued use.

Another object of my invention resides in the provision of means by which ready access may be had to the interior of the socket to affix or attach the lead-wires.

My invention has for a further object the provision of means by which the current may be cut on or off from the filament by a slight pressure and the most natural movement of the hand, the key by which this result is accomplished being of the most simple construction and so held as that no jarring of the parts will dislocate the said key when the latter assumes the position by which the current is cut off.

My object, further, is to provide a socket embodying the above and other features, of the utmost simplicity, of minimum size, and adapted to carry the maximum of current.

My invention consists in an exterior sectional casing, interior insulating-partitions having secured thereto conducting-pieces, to which the main leads of the circuit are connected, moving contact-pins acted upon by yielding pressure, one of which pins is connected with an actuator, which latter travels and is held within an approximately angular slot, a base-receiving chamber having an interior insulating fixed lining, yielding pressure devices fixed at a given point and acting upon the lower section of the exterior casing

when said section is rotated, together with vertical slots in the fixed lining and diagonal slots or beads in the lower moving section of the casing, the aforesaid parts constituting the socket of the lamp, the base of the lamp comprising contact-plates connected with the leads to the filament, and projecting lugs or pins extending from the sides of the base.

My invention consists, further, in certain details of construction, hereinafter set forth, reference being now had to the accompanying drawings, in which—

Figure 1 is a side elevation of my improved socket and also the base of an incandescent lamp having contact-plates and engaging-lugs. Fig. 2 is a like view in the direction of the arrow, Fig. 1. Fig. 3 is a vertical section on the line X X, Fig. 1. Fig. 4 is a side elevation of the socket, the casing being broken away to show the devices acting upon the movable portion of the casing. Fig. 5 is an enlarged detail sectional view of the lower portion of the socket, being in this instance shown in an inverted position relative to the other views. Fig. 6 is an enlarged detail view of one of the metallic casings, the contact-plugs, and spring-actuator. Fig. 7 is a detail view of the upper portion of the exterior casing broken away to show the attachment of the cap-piece to the insulating-partition and also the slot to adapt the casing to be removed.

The numerals 10 and 11, Fig. 3, designate insulating-partitions, which extend, respectively, longitudinally and transversely of the socket 12. Secured to each side of the partition 10 are the conducting-pieces 13 and 14, to which the main leads 15 and 16 are connected by the binding-screws 17 and 18, a cap-piece 19 covering the upper end of the socket 12. The casing or jacket of the socket 12 comprises an upper section 20 and a lower rotatable section 21, the latter being secured to the former by means of a bead 22, so that the section 21 is permitted a movement of rotation independent of the section 20. Within the interior of the lower section 21 is an immovable annular insulating-lining 23, which may be formed integral with the partition 11, said lining and the section 21 of the casing constituting the walls of the chamber adapted to receive the base, in manner to be hereinafter described. The numeral 24 designates vertical slots,

Fig. 5, which are cut in the lining 23 and extend to and coincide with the annular slot 25, formed by the bead 26. Formed in the lower portion of the section 21 are upwardly-extending diagonal raceways 27, which at their upper ends terminate and coincide with the annular slot 25, formed by the bead 26, and are located on opposite sides of said section. The vertical slots 24 are located on opposite sides of the lining 23, the lower ends of said slots 24 coinciding with the lower ends of the raceways 27.

Extending upwardly from the under side of the partition 11 are the slotted metallic casings 28 and 29, bedded within bores in the said partition, so that passages are provided though the latter on each side of the vertical partition 10. Located vertically within these casings 28 and 29 are the pins 30 31, to the lower ends of which the contact-buttons 32 33 are secured. Encircling the said pins are the spiral springs 34 35, the upper ends of which are secured to the conducting-pieces 13 and 14, their lower ends being secured to or bearing against the contact-buttons 32 33. The upper portion of the length of the pin 31 is bent at right angles and extends through an approximately angular slot 36 in the casing 20. The upper end portion of this pin 31 is screw-threaded to receive the female threads of an actuator-key 37, which latter travels within and is held in position by the angular slot 36. Secured to or held within the insulating-partition 11 is a spring 38, Fig. 4, bearing against and acting upon a pin 39, secured to the rotatable lower section 21.

The numeral 40, Fig. 2, designates a screw traveling in a slot, which serves to limit the movement of rotation of the lower section 21 in either direction.

The hereinbefore-described parts constitute the socket 12.

The base 41 of the lamp has projected from opposite sides the lugs 42, and also the contact-plates 43 on its upper face, to which contact-plates 43 the leads to the filament are secured. The lugs 42 are located on a plane intermediate between the plates 43.

The cap-piece 19 is attached to the insulating-partition 10 by means of screws 44 44, Fig. 7, a slot 45 extending from the angular slot 36 to the upper edge of the casing 20, covered by the depending strip 46.

The operation of my improved device and the particular advantages thereof are as follows: Referring to the socket 12 it will be seen that ready and convenient access is had to the interior thereof by loosening the screws 44 44, when the two section 20 and 21 may be withdrawn downwardly, the actuator-key 37 traveling through the slot 45, and after connecting or disconnecting the leads 15 and 16, as desired, may be replaced and adjusted with facility. In joining the lamp-base 41 to the socket 12 the lugs 42 are caused to register with the coinciding lower terminations of the vertical slots 24 and the diagonal raceways

27. When imparting to the lamp-base a slight upward movement, the said lugs 42 are caused to travel within the vertical slots 24 and the raceways 27, and since the lining 23, in which are the vertical slots 24, is stationary and the lower section 21 of the casing, in which are the raceways 27, is rotatable said section 21 is slightly rotated in the direct vertical movement of the lugs 42 of the base 41 in the slots 24 against the resiliency of the spring 38, bearing against the pin 39, secured to the said section 21. When the lugs 42 reach the annular groove 25, formed by the bead 26, the said lugs pass into said groove, thus releasing the raceways 27, whereupon the spring 38 operates upon the pin 39 to rotate the lower section 21 again into its normal position, thus locking the lugs 42 within said groove. In order to detach the lamp from the socket, the lower section is rotated or turned until the lugs register with the vertical slots 24, when the lamp may be withdrawn. It is now obvious that the connection or detachment of the base to the socket is effected in the most simple manner, in the one case the movement being a simple upward one and in the other a mere movement of the lower section 12, the screw 40 in each case limiting the rotation of the section, by this means entirely dispensing with those means which require such manipulation in securing the lamp to the socket as that the connection between the globe and base is disturbed and weakened. It is also seen that the connection between the lamp and socket is secure and firm, the lugs being automatically locked into the groove 25 in the bead 26. In the joining of the lamp to the socket the base of the lamp enters into the lower chamber of the socket, and its contact-plates 43 impinge against the heads 32 33 on the pins 30 31, compressing the springs 34 35, and thus establishing a positive, complete, and firm contact. The current is cut on or off from the lamp by means of the actuator-key 37, which latter is held within the angular slot 36 in the casing 20, said key, when the circuit is broken, being held by the upper portion of said slot 36 against the resiliency of the spring 35, the head 33 being thus held apart from one of the contact-plates 43. The circuit is readily established by a simple and slight pressure upon the key 37, when the latter is disengaged from the upper portion of the slot 36, permitting the spring 35 to cause the head 33 to seat and bear upon the contact-plate 43. In order to break the circuit, a slight upward or lateral pressure upon the key 37 causes the latter to engage in the upper portion of the angular slot 36 and separate the head from the plate. It is now obvious that the key in performing its functions is actuated by the most simple and natural movement of the hand, either in turning on the light in the darkness or in cutting off the light in elevated position. The simplicity of movement especially adapts the lamp to be connected to or

detached from the socket at elevated positions with convenience and facility. An abrupt and almost instantaneous separation of the contact between the head 33 and one of the plates 43 avoids arcing, and the disposition of the insulating material prevents the connection from heating, and thus obviates any of the incident difficulties, such as bending or warping of the connecting parts. The disposition of the lugs 42 and the vertical slots 24 relatively to each other respectively on the base and in the lining 23 is such as that the contact-plates 43 invariably register with the heads 32 33 on the extremities of the plugs 30 31.

Having thus described my invention, what I claim as new therein, and desire to secure by Letters Patent, is—

1. The combination, with the base of an incandescent lamp having projecting lugs and contact-plates fixed thereto, of a socket comprising an exterior casing formed in sections, which latter are independent of one another in movement, interior insulating-pieces, contact-pins acted upon by yielding pressure devices, an approximately angular slot in one of said sections of casing, an actuator held by and traveling within said angular slot, approximately vertical slots in a stationary portion of the socket, raceways in the rotating section of casing disposed angularly relatively to said vertical slots, and a groove for receiving the lugs on the base, together with yielding pressure devices acting upon the rotatable section of casing.

2. The combination, with a base of an incandescent lamp having projecting lugs and contact-plates, of a socket comprising interior insulating portions, an exterior casing formed in sections having independent movements, contact-plugs acted upon by yielding pressure devices, approximately vertical slots in a fixed portion of the socket, raceways in the rotatable section of casing disposed angularly relatively to the said vertical slots, and a groove to receive and hold the lugs of the base, together with yielding pressure devices acting upon said rotatable section of casing when the socket is coupled to the lamp.

3. The combination, with the base of an incandescent lamp having lugs or pins projecting therefrom, contact-plates secured thereto, and leads from said contact-plates to the filament, of a socket comprising interior insulating-partitions, conducting-pieces to which the main leads of the exterior circuit are connected, an outer casing formed of two independent sections, one of which sections has a movement of rotation, contact plugs or pins electrically connected with the conducting-pieces and acted upon by yielding pressure devices, approximately vertical slots formed in a fixed portion of the socket, raceways formed in the

rotatable section of casing and disposed approximately angularly relative to the vertical slots, and yielding pressure devices held upon a stationary portion of the socket acting upon the movable section of casing in the act of joining the base to the socket, together with a groove adapted to receive and hold the lugs on the base when the latter is joined to the socket.

4. The combination, with the base of an incandescent lamp having lugs or pins projecting therefrom, contact-plates secured thereto, and leads from said contact-plates to the filament, of a socket comprising interior insulating-partitions, conducting-pieces to which the main leads of the exterior circuit are connected, an outer casing formed of two independent sections, one of which sections has a movement of rotation, contact plugs or pins electrically connected with the conducting-pieces and acted upon by yielding pressure devices, an approximately angular slot in a stationary portion of the socket, an actuator attached to one of the contact-pins traveling within and held by said angular slot, approximately vertical slots formed in a fixed portion of the socket, raceways formed in the rotatable section and disposed approximately angularly relative to the vertical slots, and yielding pressure devices held upon a stationary portion of the socket acting upon the rotatable section of casing in the act of joining the base to the socket, together with a groove adapted to receive and hold the lugs on the base when the latter is joined to the socket.

5. Means for joining and holding the base of an incandescent lamp, consisting of a rotatable section of casing on the socket, vertical slots in a stationary portion of the socket, raceways formed on said section of rotatable casing, arranged approximately angularly relative to the vertical slots, together with yielding pressure devices held upon a stationary part of the socket acting upon the rotatable section of casing, and a groove adapted to receive and hold lugs on the base portion when the latter is joined to the socket.

6. The combination, with the base of an incandescent lamp having contact-plates fixed thereto, of a socket comprising interior insulating-partitions, vertical bores in one of said partitions, in which are located contact-plugs, conducting-pieces to which the main leads are attached, yielding pressure devices attached to said conducting-pieces and adapted to conduct the current, acting upon the contact-plugs, an approximately angular slot formed in the casing, and an actuator secured to one of the said plugs, traveling within and held by said angular slot, together with means for detachably joining the base to the socket.

HARRY J. GUTMAN.

Witnesses:

C. C. BULKLEY,
S. C. SWEET.