

Jan. 9, 1951

R. W. BROWN ET AL
CONVEYER APPARATUS

2,537,005

Filed March 18, 1949

2 Sheets-Sheet 1

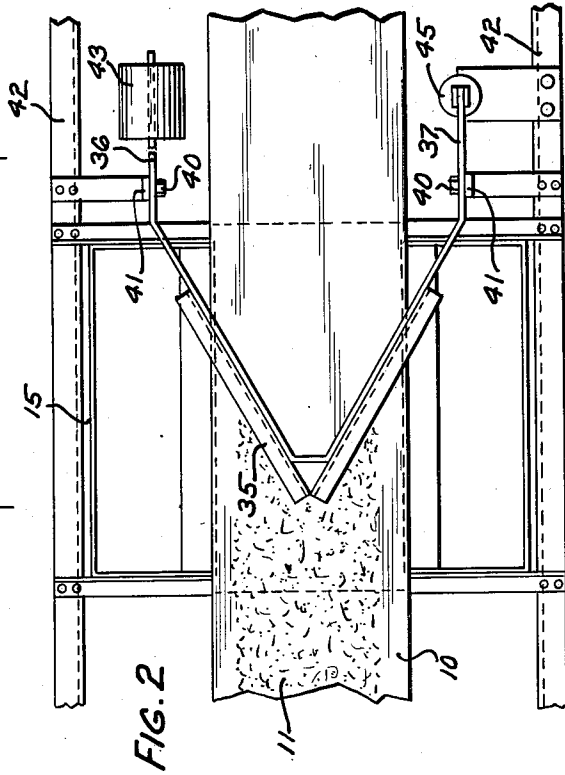
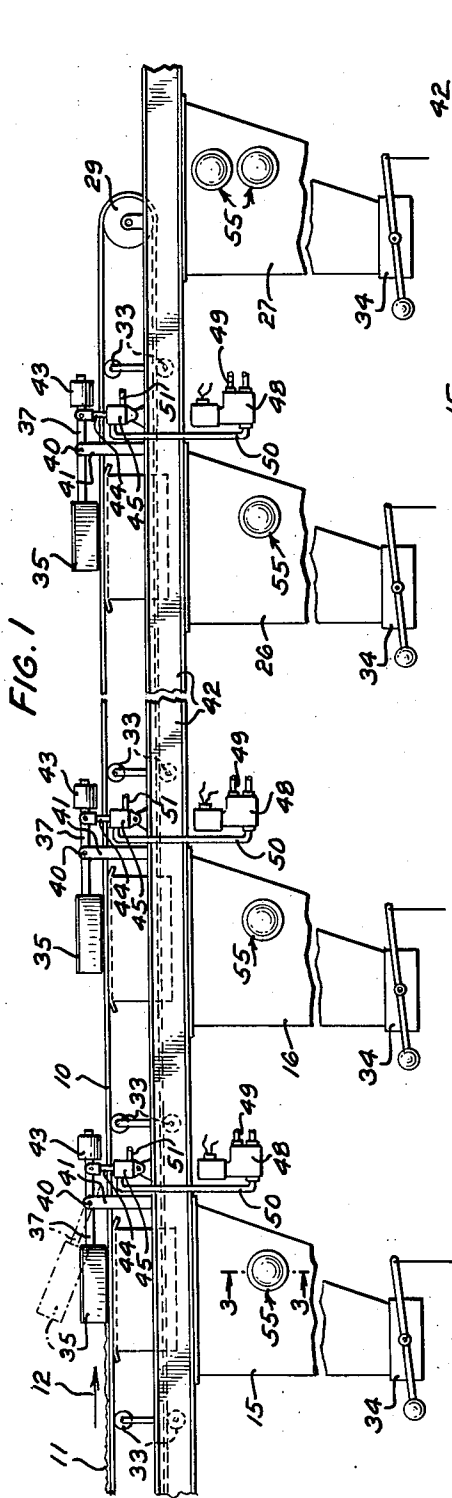

FIG. 2

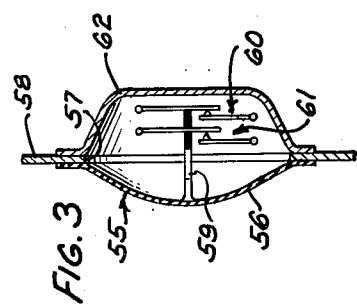

FIG. 3

INVENTORS
R. W. BROWN
G. H. FRANK
BY *E. J. Kaul*
ATTORNEY

Jan. 9, 1951

R. W. BROWN ET AL
CONVEYER APPARATUS

2,537,005

Filed March 18, 1949

2 Sheets-Sheet 2

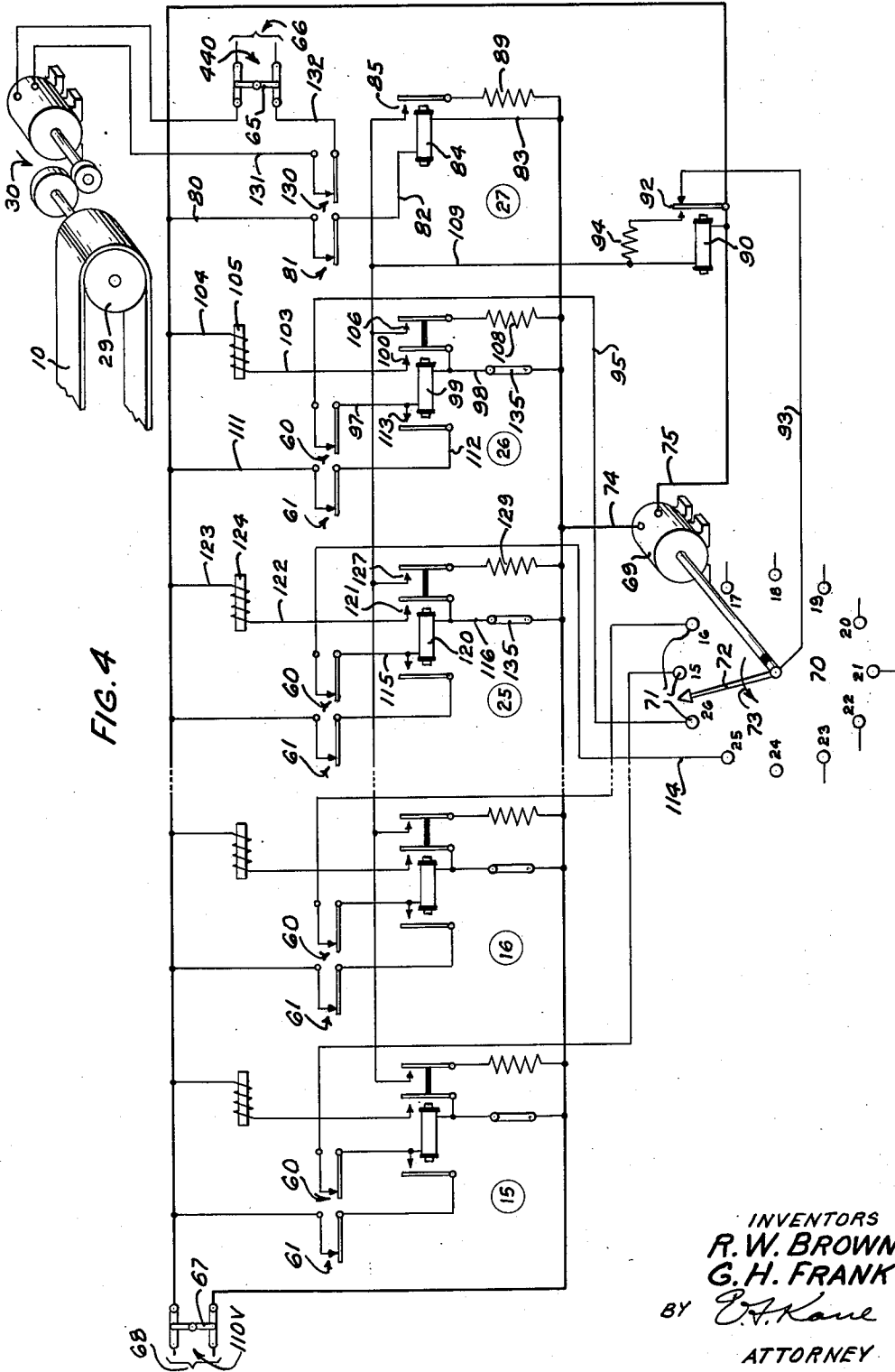

UNITED STATES PATENT OFFICE

2,537,005

CONVEYER APPARATUS

Raymond W. Brown, Evergreen Park, and George H. Frank, Oak Park, Ill., assignors to Western Electric Company, Incorporated, New York, N. Y., a corporation of New York

Application March 18, 1949, Serial No. 82,124

7 Claims. (Cl. 198—38)

1

This invention relates to conveyor apparatus and more particularly to apparatus for controlling the feeding of granular materials as needed to a plurality of receptacles.

It is an object of the present invention to provide a simple and efficient apparatus for maintaining predetermined quantities of granular materials at all times in a series of receptacles arranged along a main material supply conveyor.

In accordance with one embodiment of the invention as applied to a conveyor and distributing apparatus for automatically supplying and controlling the feeding of molding sand as needed to a series of molder's supply bins, there is provided a belt for carrying a supply of sand along the line of bins. Above each bin, except the last bin in the series, a movable plow is mounted which, while in an operative position adjacent the upper plane of the advancing belt, serves to deflect sand from the belt into the associated bin. Switch mechanisms sensitive to the pressure of the sand are so arranged in the bins that circuits are completed to maintain the plows in operative sand-deflecting positions until a predetermined amount of sand is deposited in each of the bins, whereupon the circuits are broken and the plows are withdrawn from their operative positions. The last bin in the series, which receives the sand remaining on the belt after passing the plows, is provided with two switch mechanisms, one of which operates in conjunction with the plow control circuits when this bin is partially filled to prevent subsequent operation of any plow until the last bin is filled to a predetermined level. The other switch mechanism in the last bin is operated when this bin becomes completely filled or is apt to overflow to shut down the sand-conveying apparatus. A motor-operated stepping switch is provided to co-operate with the several bin-controlled switch mechanisms and control the plow circuits so that not more than two of the plows will be in sand-deflecting position at any one time. Furthermore, the circuits are so arranged that the switch in the next-to-the-last bin, when operated, will prevent subsequent operation of any plow until the next-to-the-last bin is filled to a predetermined level.

A better understanding of the invention may be had by reference to the following detailed description when considered in conjunction with the accompanying drawings, wherein

Fig. 1 is a fragmentary side view of a sand-conveying and distributing apparatus embodying the features of this invention with the units between

2

the first two and last two units omitted to conserve space;

Fig. 2 is a plan view of the first or left-hand unit of Fig. 1;

Fig. 3 is an enlarged vertical sectional view taken along the line 3—3 of Fig. 1; and

Fig. 4 is a circuit showing the means for controlling the various units of the sand-conveying and feeding apparatus and the operation of the entire apparatus as a whole.

Referring now to the drawings, with particular reference to Figs. 1, 2 and 3, showing the mechanical equipment and arrangement of the conveying and distributing apparatus, there is provided an endless conveyor in the form of a belt 10, on which granular material 11, such as sand in the present instance, has been deposited at its left end, Figs. 1 and 2, and is carried in the direction of the arrow 12. Sand is fed from opposite sides of the belt 10 into a series of spaced molder's supply bins supported below the belt.

Any desired number of receptacles or bins may be provided and, for purposes of illustration, the first two bins 15 and 16 and last two bins 26 and 27 of a series are shown in Fig. 1, whereas, the electrical controls for the first two bins 15 and 16 and last three bins 25, 26 and 27 are shown in Fig. 4. The belt 10 is trained around the pulleys, one of which is not shown and the other of which is designated 29, and is driven from an electric motor and suitable speed reduction mechanism indicated at 30 (Fig. 4). Rollers 33—33 serve to support the upper and lower lengths of the belt 10. The bins, as shown in Fig. 2, extend beyond the opposite longitudinal edges of the belt 10 so that sand, when fed from such belt edges, will drop into the bins during the advance of the belt in the direction of the arrow 12. At their lower ends, the bins are equipped with dispensing valves or gates 34—34, manually controlled by the molders stationed adjacent each bin to cause sand, as needed, to be supplied by gravity from the bins, which, in the operation of the apparatus, are maintained with a predetermined quantity of sand supplied from the belt 10 whenever the supply of sand in any bin falls below a certain level therein. Arranged above the plane of the upper length of the belt 10, and in alignment with each of the bins, with the exception of the bin 27, is a V-shaped plow 35, having its closed end facing in the direction opposite to the direction of movement of the belt and the sand carried thereon. Each plow 35 is provided with rearwardly extending spaced parallel arms 36—37 (Fig. 2), which are pivoted at 40—40, to vertical support

3

bars 41—41, which may be secured to a framework 42 extending along the belt 10, series of bins and plows 35—35. The rollers 33—33 are rotatably supported from the framework 42, and the bins are suspended therefrom.

Adjustably mounted on each of the plow arms 36 (Fig. 2) is a counterweight 43, which serves to prevent the plow 35 from dropping suddenly when released from its inoperative upper position, shown in broken outline (Fig. 1) to its operative lowered position, wherein it is effective to deflect sand from the belt 10 into the associated bin. Each of the plow arms 37 is connected to a piston rod 44 of an air cylinder 45, the supply of air under pressure to the cylinder to maintain the plow in its upper inoperative position being controlled by a solenoid-operated air valve 48 (Fig. 1), having its inlet port connected by a conduit 49 to a main source of air under pressure (not shown). A conduit 50 connects the air cylinder 45 with the valve 48, which conduit supplies air to the cylinder through the valve and also serves as an exhaust conduit from the cylinder into the valve and through an exhaust conduit 51 of the latter to atmosphere. When the solenoid of the air valve 48 is energized, the supply of air under pressure to the cylinder 45 is cut off by the valve and the plow 35 falls by gravity under the control of the counterweight 43. Upon deenergization of the solenoid of the air valve 48, the valve is actuated to cause air under pressure to flow and operate the piston in the cylinder 45, which moves down, and by means of the piston rod 44 connected thereto the plow is moved about its pivots 40—40 to its upper inoperative sand-deflecting position, where it remains until the solenoid of the air valve 48 is again energized.

In the particular arrangement disclosed, no plow 35 is necessary above the extreme right-hand end bin 27 of the series (Fig. 1), since the end of the upper length of the belt 10, where it is trained around the pulley 29, is aligned with such bin and discharges directly thereinto. This right-hand bin 27 will thus receive any sand remaining on the belt 10 that is not discharged therefrom by the series of plows 35. The amount of sand fed into each of the bins, including the right-hand bin 27 (Fig. 1) from the belt 10 and the operation of the apparatus as a whole, is controlled by an electric circuit (Fig. 4), which includes pressure-sensitive switch mechanisms 55—55 (Fig. 3) mounted in one wall of each of the bins, one in each bin, except the right-hand bin 27, which is equipped with two vertically disposed switch mechanisms, the lower of which is opened when the bin is three-fourths filled and the upper when the bin is completely filled and tending to overflow.

Each pressure-sensitive switch mechanism 55 associated with each bin is identical in construction, with the exception of the switch in bin 27, and, as shown somewhat diagrammatically in Fig. 3, may comprise a circular-shaped diaphragm 56 of suitable flexible material, which is sealed and secured around an opening 57 provided in a vertical wall 58 of the bin at a certain level. The diaphragm 56, when the bin is empty or not filled to the desired level, will normally extend inwardly from the inner surface of the wall 58, as shown, but when the bin is sufficiently filled with sand, the pressure of the sand against the diaphragm causes it to be deflected outwardly. Attached centrally to the outer face of the diaphragm 56 is a switch-actuating member 59, arranged to make and break contact with two sets of normally

4

closed contacts 60 and 61. A cup-shaped cover 62, attached to the outer face of the bin, serves to enclose the switch mechanism 55, which is suitably connected to the electric circuit shown in Fig. 4.

Preparatory to a description of the operation of the apparatus, it will be assumed that the indicated bins 15, 16, 25, 26 and 27 (Figs. 1 and 4), as well as the intermediate bins (not shown), are empty of sand and, consequently, all of the contacts 60 and 61 of the switch mechanisms 55 associated with each of the bins 15 to 26, inclusive, are closed, as well as contacts of the switch mechanism 55 of the bin 27, as shown in Figs. 3 and 4, and, further, referring to Fig. 4, that a switch 65 is closed to supply current from a 440 volt source 66 to the belt-driving motor 30 and also a switch 67 has been closed to supply current from a 110 volt source 68 to operate the various electrically-controlled mechanisms in the apparatus including a motor 69 for continuously driving a stepping switch 70 (Fig. 4). The stepping switch 70 is provided with a plurality of contacts 71, one for each plow 35, and a rotatable contact arm 72, which, by means of its driving motor 69, makes one complete revolution in the direction of the arrow 73 in about ten seconds.

Assuming this condition of the apparatus, power will be supplied from the 110 volt line 68 through leads 74 and 75 to operate motor 69 to drive the contact arm 72, which at this instant, is shown positioned intermediate a pair of contacts 71. Power is also supplied from the upper side of the line 68 through lead 80, normally closed contacts 81 of the lowermost sand pressure-sensitive switch mechanism 55 of the bin 27. This closes a circuit through leads 82 and 83 to energize a relay 84 to close contacts 85. Energization of relay 84 will complete a circuit through a resistance 89 and coil of a relay 90 to energize the relay 90. Since the resistance 89 has a relatively low resistance, sufficient current is passed to operate relay 90 and, as soon as this latter relay is operated, current is disconnected from the contact arm 72 of the stepping switch 70, which is supplied from the upper side of the line 68 through break contact 92 and lead 93. Energization of relay 90 will also connect a shunting resistance 94 in parallel with the relay winding. Thus, the bin 27, which does not have a plow 35, will, for a time, be the only bin to receive sand from the belt 10, which discharges directly into this bin and, when it is three-fourths filled, the normally closed contacts 81 of the lowermost switch mechanism 55 will open and relays 84 and 90 will be deenergized. Current is thus again connected to rotating contact arm 72 and, assuming that the arm will next make contact with the contact 71 associated with the plow 35 of the bin 26, power will be supplied from the upper side of line 68 through contact 92, lead 93, contact arm 72, engaged contact 71, lead 95, normally closed contacts 60 of the sand pressure-sensitive switch mechanism 55 of the bin 26. This closes a circuit through leads 97 and 98 to the lower side of the line 68 to energize a relay 99, which closes contacts 100 and supplies current over leads 103 and 104 to energize a solenoid 105 of the air valve 48, whereupon the valve is actuated to cut off the supply of air to the plow lifting cylinder 45 and the associated plow 35 falls by gravity under the control of the counterweight 43 to its operative sand-deflecting position relative to the advancing belt 10. Upon energization of the relay 99, a second set of contacts 106 thereof is closed and cur-

rent is supplied through a resistance 108 over lead 109 to again energize the relay 90 to disconnect the current from the contact arm 72. Resistance 108 has the same resistance as resistance 89 previously mentioned, so that sufficient current is passed to operate the relay 90 and the contact arm 72 is again disconnected from the line 68, with the result that none of the other plows 35 of the bins 15 to 25, inclusive, can be lowered until bin 26 is filled. A holding circuit for the relay 99 is closed when this relay is energized, which runs from the upper side of the line 68 through lead 111, normally closed contacts 61 of the associated switch 55, lead 112, closed relay contacts 113, and lead 98 to the lower side of the line 68. Thus, during the continued rotation of the contact arm 72, the solenoid 105 is held energized and the plow 35 in its lowered sand-deflecting position until the associated bin 26 is filled sufficiently with sand to operate its switch mechanism 55 to open its normally closed contacts 60 and 61.

Upon the opening of the contacts 60 and 61 of the bin 26, the relays 99 and 90 are deenergized along with the solenoid 105. The deenergization of the solenoid 105 actuates the air valve 48 to cause air under pressure to flow and operate the piston in the cylinder 45 and raise the plow 35 to its upper inoperative position. The deenergization of relay 90 again connects the contact arm 72 to the line 68 and, depending upon its rotary position, it will engage one or the other of the contacts 71. For convenience of description at this time, it will be assumed that the contact 71 for the bin 25 will, at this time, be next engaged by the contact arm 72. Thus, current will be supplied from the upper side of the line 68, contact 92, lead 93, contact arm 72, engaged contact 71, lead 114, and normally closed contacts 60 of the switch mechanism 55 of the bin 25. A circuit is thus closed through leads 115 and 116 to the lower side of the line 68 to energize a relay 120, which closes contacts 121 to supply current over leads 122 and 123 to energize a solenoid 124 to effect, in the manner previously described, a lowering of the associated plow 35 to its operative position. The operation of relay 120 also closes its contacts 127 to supply current through a resistance 129 to the winding of relay 90. Relay 90, however, will not be operated at this time since the resistance of resistance 129 is relatively high and will block the operation of relay 90 until another plow has been dropped and a second resistance associated with one of the other bins is connected in parallel with resistance 129. Therefore, the contact arm 72 continues to rotate and, assuming that the arm will next make contact with the contact 71 associated with the plow 35 of the bin 16, such plow will be lowered to its operative position by the closing of a circuit to the relay 90 similar to that described in connection with the lowering of the plow 35 of the bin 25, the two circuits through the winding of the relay 90 being in parallel. The resistances in the contact arm circuits for each of the bins 15 to 25, inclusive, are all similar and of such value that the relay 90 will not be energized to complete the circuit through the contact arm 72 with one resistance in such circuit, but with two such resistances in parallel, sufficient current will flow to energize the relay 90. Two plows 35 are now in their lowered operative positions, which serves to prevent overloading of the conveyor belt mechanism and also prevents leavings of sand on the belt 10 from completely filling the bin 27 and

shutting down the conveyor belt when the other bins need sand.

At times, the bin 27 becomes completely filled and is apt to overflow since it receives all sand left on the belt 10 by the plows 35. In this case, the uppermost sand pressure-sensitive switch mechanism 55 of the bin 27 is actuated to open its normally closed contacts 130, thus disconnecting the 440 volt line 66 to the belt driving motor 30 through leads 131 and 132 and the belt is stopped and when the excess sand is used up, the belt-driving circuit is automatically closed and the apparatus continues its operation.

At this period in the described operation of the apparatus, two bins 25 and 16 are being filled and, upon bin 25 being sufficiently filled, its normally closed contacts 60 and 61 will be opened and the relays 120 and 90 will be deenergized, thus causing the associated plow 35 to be raised and the circuit through contact 92 to the contact arm 72 to be closed. This permits another empty bin to be filled with sand by the lowering of its plow while the bin 16 continues to be filled.

Switches 135 are included in each of the bin-filling control circuits so that any one or more bins can be shut off from the sand supply conveyor belt 10 without affecting the operation of the apparatus as a whole, with the exception of the last bin 27, which does not have a deflecting plow 35, but receives its sand directly from the end of the belt.

In the normal operation of the apparatus, if it be assumed that bin 27 is three-fourths full of sand and the contact arm 72 engages any contact 71 for the bins 15 to 26, inclusive, a plow 35 will be lowered for that bin and, when the contact arm engages another contact whose bin is calling for sand, the second relay will be energized to close its contacts to form a parallel path with the previously energized relay to energize the relay 90, thus disconnecting the line 68 from the contact arm 72 until the first of the two bins having plows is filled.

From the above-described control circuits, it will be noted that two plows 35 may be in operative position at all times, except when bins 26 and 27 are being filled or when all bins or all but one bin are full.

It is to be understood that the above-described arrangements are simply illustrative of the application of the principles of the invention. Numerous other arrangements may be readily devised by those skilled in the art which will embody the principles of the invention and fall within the spirit and scope thereof.

What is claimed is:

1. In an apparatus for handling granular material having a line of receptacles to be supplied with granular material as needed, the combination of a conveyor belt for carrying the granular material along the line of receptacles, means for moving said belt, a movable material deflector mounted above said belt, one for each receptacle, except the last receptacle in the line which receives any material not removed from the belt by the deflectors, power means for effecting movement of said deflectors into operative and inoperative positions, material pressure-responsive switches in each receptacle operable upon a predetermined amount of material being supplied to the receptacles, an electrical circuit responsive to operation of the switches for causing said power means to move the deflectors to their inoperative position, a stepping switch in said circuit for controlling the effectiveness of the receptacle

7

switches, with the exception of the switch in the last receptacle in the line, to control the supply of material to the receptacles, and means in said circuit whereby either one or two deflectors may be in operative position at one time.

2. In an apparatus for conveying and feeding granular material to a line of receptacles as needed to maintain a predetermined supply therein, the combination of a line of receptacles, an endless travelling belt for carrying a supply of material along the line of receptacles, movable deflectors mounted above the belt, one in line with each receptacle except the last receptacle in the line which receives material fed off the end of the belt, said deflectors effective in their operative positions to cause material to be deflected from the belt into the receptacles, means for effecting movement of said deflectors into operative and inoperative positions, a material pressure-responsive switch in each receptacle except the last receptacle in the line, two material pressure-responsive switches in said last receptacle arranged in upper and lower planes, an electrical circuit including said switches responsive to the amount of material in the line of receptacles for controlling the operations of the deflectors, means in said circuit whereby either one or two deflectors may be in operative position at one time, and means in said circuit responsive to the operation of said switches in the last receptacle whereby the lower switch which is connected to the deflector circuit will operate when said receptacle is partially filled and the upper switch will operate when said receptacle is completely filled to stop the effective operation of the apparatus.

3. In a control circuit for controlling the feed of material to a plurality of receptacles positioned adjacent a travelling conveyor belt, the combination of a set of pressure-sensitive switches in each of a plurality of receptacles, a relay individual to each receptacle and having its coil in series with one switch of the set in the associated receptacle, a locking circuit for each relay connectible through the other switch of the set in the associated receptacle, a current source, means for sequentially connecting said one switch of each set to the current source, means operable under the joint control of any two relays for disconnecting the sequential connecting means from the current source, and means individual to each of said relays and operable under control thereof for directing material from the conveyor belt to its associated receptacle.

4. In a control circuit for controlling the action of means to feed material to a plurality of receptacles positioned adjacent a travelling conveyor belt, the combination of a set of pressure-sensitive switches in each of a plurality of receptacles, a relay individual to each receptacle and having its coil in series with one switch of the set in the associated receptacle to control the feeding means, a locking circuit for each relay connectible through the other switch of the set in the associated receptacle, a current source, means for sequentially connecting said one switch of each set to the current source, means operable under the joint control of any two relays for disconnecting the sequential connecting means from the current source, an end receptacle positioned adjacent the end of the conveyor belt, a pressure-sensitive switch in said end receptacle, and means controlled by the pressure-sensitive switch in the end receptacle for disconnecting the sequential connecting means from the current source.

8

5. In a control circuit for controlling the feed of material to a plurality of receptacles positioned adjacent a travelling conveyor belt, the combination of a set of pressure-sensitive switches in each of a plurality of receptacles, a relay individual to each receptacle and having its coil in series with one switch of the set in the associated receptacle, a locking circuit for each relay connectible through the other switch of the set in the associated receptacle, a current source, means for sequentially connecting said one switch of each set to the current source, a control relay operable under the joint control of any two relays for disconnecting the sequential connecting means from the current source, a high resistance path connectible to the control relay by each of said relays individual to receptacles to form parallel circuits whereby, when any two relays individual to receptacles are operated, the control relay will be operated to disconnect the sequential connecting means from the current source, and means individual to each of said relays and operable under control thereof for directing material from the conveyor belt to its associated receptacle.

6. In a control circuit for controlling the feed of material to a plurality of receptacles positioned adjacent a travelling conveyor belt, the combination of a series of pressure-sensitive switches responsive to material in each receptacle, material deflecting means for each receptacle, means for rendering said deflecting means operable to deflect the material from the conveyor belt to a receptacle, a relay associated with each receptacle and operable upon energization for supplying current to actuate the deflecting means, a receptacle at the end of the conveyor belt also having a pressure-sensitive switch therein, a relay operable under control of said last-mentioned pressure-sensitive switch, a main control relay, means operable for sequentially supplying current to the relays associated with the series of pressure-sensitive switches under control of said main control relay, means operable under control of the relay associated with the last receptacle for operating said main control relay to block the flow of current to said sequential device, and means under control of any two operated relays of the series of relays for operating said main control relay.

7. In a control circuit for controlling the feed of material to a plurality of receptacles positioned adjacent a travelling conveyor belt, the combination of a series of pressure-sensitive switches responsive to material in each receptacle, material deflecting means for each receptacle, means for rendering said deflecting means operable to deflect the material from the conveyor belt to a receptacle, a relay associated with each receptacle and operable upon energization for supplying current to actuate the deflecting means, a receptacle at the end of the conveyor belt also having a pressure-sensitive switch therein, a relay operable under control of said last-mentioned pressure-sensitive switch, a main control relay, means operable for sequentially supplying current to the relays associated with the series of pressure-sensitive switches under control of said main control relay, a low resistance path connectible by the operation of the relay associated with the last receptacle for energizing said main control relay, and a high resistance path connectible by each of the other relays to the winding of the control relay and operable when any two said high resistance paths are connected

2,537,005

9

to the winding of the main control relay for operating the main control relay.

RAYMOND W. BROWN.
GEORGE H. FRANK.

REFERENCES CITED

The following references are of record in the file of this patent:

Number
1,304,553
1,882,440
2,195,407

10

UNITED STATES PATENTS

Name	Date
Gadd -----	May 27, 1919
Naylor -----	Oct. 11, 1932
Craggs -----	Apr. 2, 1940

FOREIGN PATENTS

Number	Country	Date
287,613	Great Britain	Mar. 21, 1928