



(86) Date de dépôt PCT/PCT Filing Date: 2015/01/07
 (87) Date publication PCT/PCT Publication Date: 2015/09/24
 (85) Entrée phase nationale/National Entry: 2017/07/24
 (86) N° demande PCT/PCT Application No.: NO 2015/050002
 (87) N° publication PCT/PCT Publication No.: 2015/142182
 (30) Priorité/Priority: 2014/01/24 (NO20140082)

(51) Cl.Int./Int.Cl. *B65G 7/12* (2006.01)
 (71) Demandeurs/Applicants:
 ROYNESTAD, TOM TORALV, NO;
 ROB, FRANK, NO
 (72) Inventeur/Inventor:
 ROYNESTAD, TOM TORALV, NO
 (74) Agent: RIDOUT & MAYBEE LLP

(54) Titre : POIGNEE DE TRANSPORT POUR UN ELEMENT DE CONSTRUCTION
 (54) Title: CARRYING HANDLE FOR A BUILDING COMPONENT

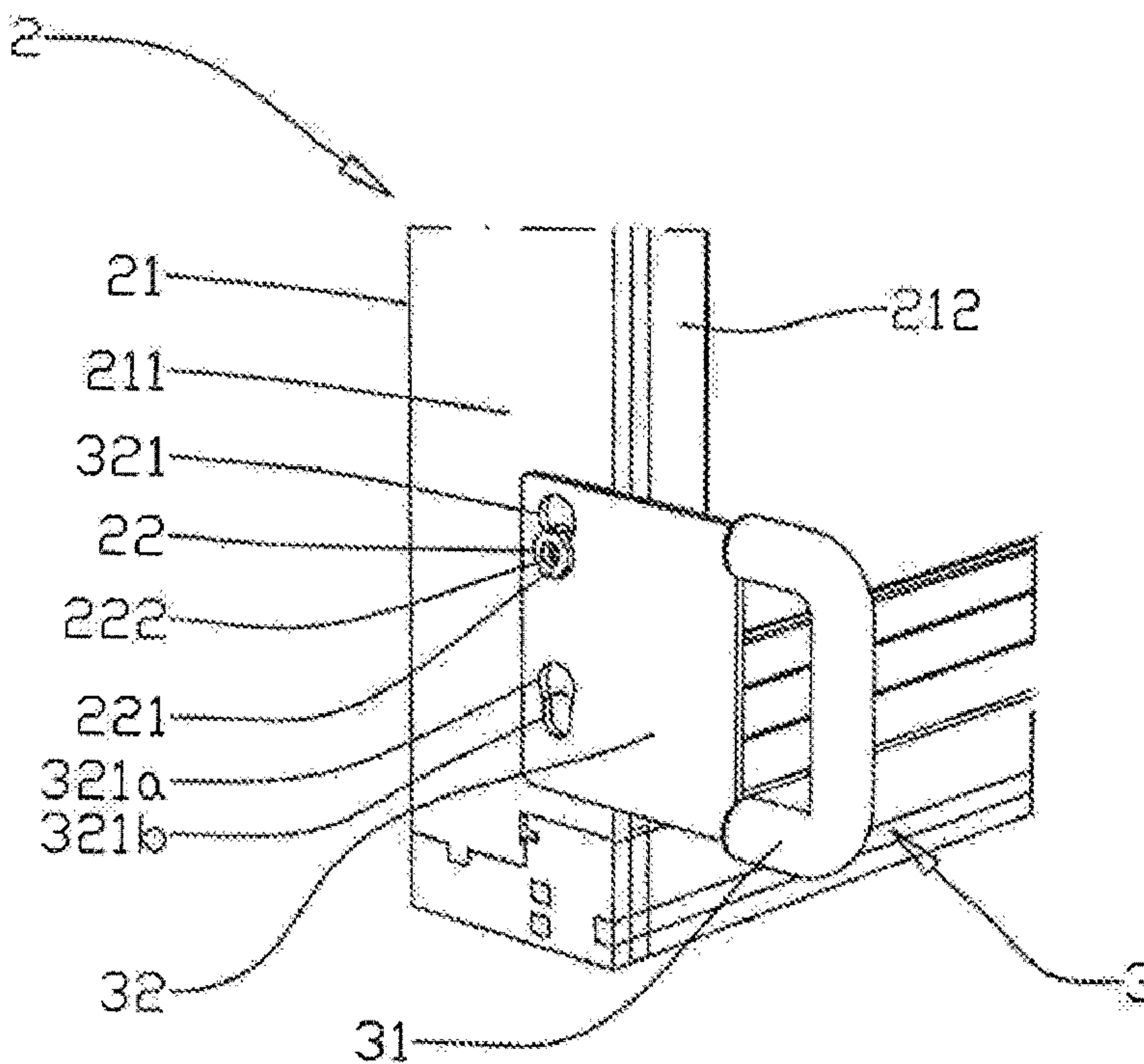

Fig. 2

(57) **Abrégé/Abstract:**

A detachable carrying-handle arrangement (3) for a building component (2), especially a window or a door including a frame (21), which is to be fixed in a supporting structure (111) surrounding an opening (11) in a building structure (1) is described, the carrying-handle arrangement (3) including a grip portion (31) connected to a plate-shaped attachment portion (32) which is provided with at least two cut-outs (321) which is arranged to lockingly engage with a fixing bolt (22).

(12) INTERNATIONAL APPLICATION PUBLISHED UNDER THE PATENT COOPERATION TREATY (PCT)

(19) World Intellectual Property
Organization
International Bureau(43) International Publication Date
24 September 2015 (24.09.2015)(10) International Publication Number
WO 2015/142182 A1(51) International Patent Classification:
B65G 7/12 (2006.01)

(21) International Application Number:

PCT/NO2015/050002

(22) International Filing Date:

7 January 2015 (07.01.2015)

(25) Filing Language:

Norwegian

(26) Publication Language:

English

(30) Priority Data:

20140082 24 January 2014 (24.01.2014) NO

(72) Inventors; and

(71) Applicants : RØYNESTAD, Tom, Toralv [NO/NO];
Øvre Røynestad, N-4480 Kvinesdal (NO). ROB, Frank
[NO/NO]; Vatland, N-4480 Kvinesdal (NO).(74) Agent: HÅMSØ PATENTBYRÅ ANS; P.O. Box 171, N-
4302 Sandnes (NO).(81) Designated States (unless otherwise indicated, for every
kind of national protection available): AE, AG, AL, AM,AO, AT, AU, AZ, BA, BB, BG, BH, BN, BR, BW, BY,
BZ, CA, CH, CL, CN, CO, CR, CU, CZ, DE, DK, DM,
DO, DZ, EC, EE, EG, ES, FI, GB, GD, GE, GH, GM, GT,
HN, HR, HU, ID, IL, IN, IR, IS, JP, KE, KG, KN, KP, KR,
KZ, LA, LC, LK, LR, LS, LU, LY, MA, MD, ME, MG,
MK, MN, MW, MX, MY, MZ, NA, NG, NI, NO, NZ, OM,
PA, PE, PG, PH, PL, PT, QA, RO, RS, RU, RW, SA, SC,
SD, SE, SG, SK, SL, SM, ST, SV, SY, TH, TJ, TM, TN,
TR, TT, TZ, UA, UG, US, UZ, VC, VN, ZA, ZM, ZW.(84) Designated States (unless otherwise indicated, for every
kind of regional protection available): ARIPO (BW, GH,
GM, KE, LR, LS, MW, MZ, NA, RW, SD, SL, ST, SZ,
TZ, UG, ZM, ZW), Eurasian (AM, AZ, BY, KG, KZ, RU,
TJ, TM), European (AL, AT, BE, BG, CH, CY, CZ, DE,
DK, EE, ES, FI, FR, GB, GR, HR, HU, IE, IS, IT, LT, LU,
LV, MC, MK, MT, NL, NO, PL, PT, RO, RS, SE, SI, SK,
SM, TR), OAPI (BF, BJ, CF, CG, CI, CM, GA, GN, GQ,
GW, KM, ML, MR, NE, SN, TD, TG).

Published:

— with international search report (Art. 21(3))

(54) Title: CARRYING HANDLE FOR A BUILDING COMPONENT

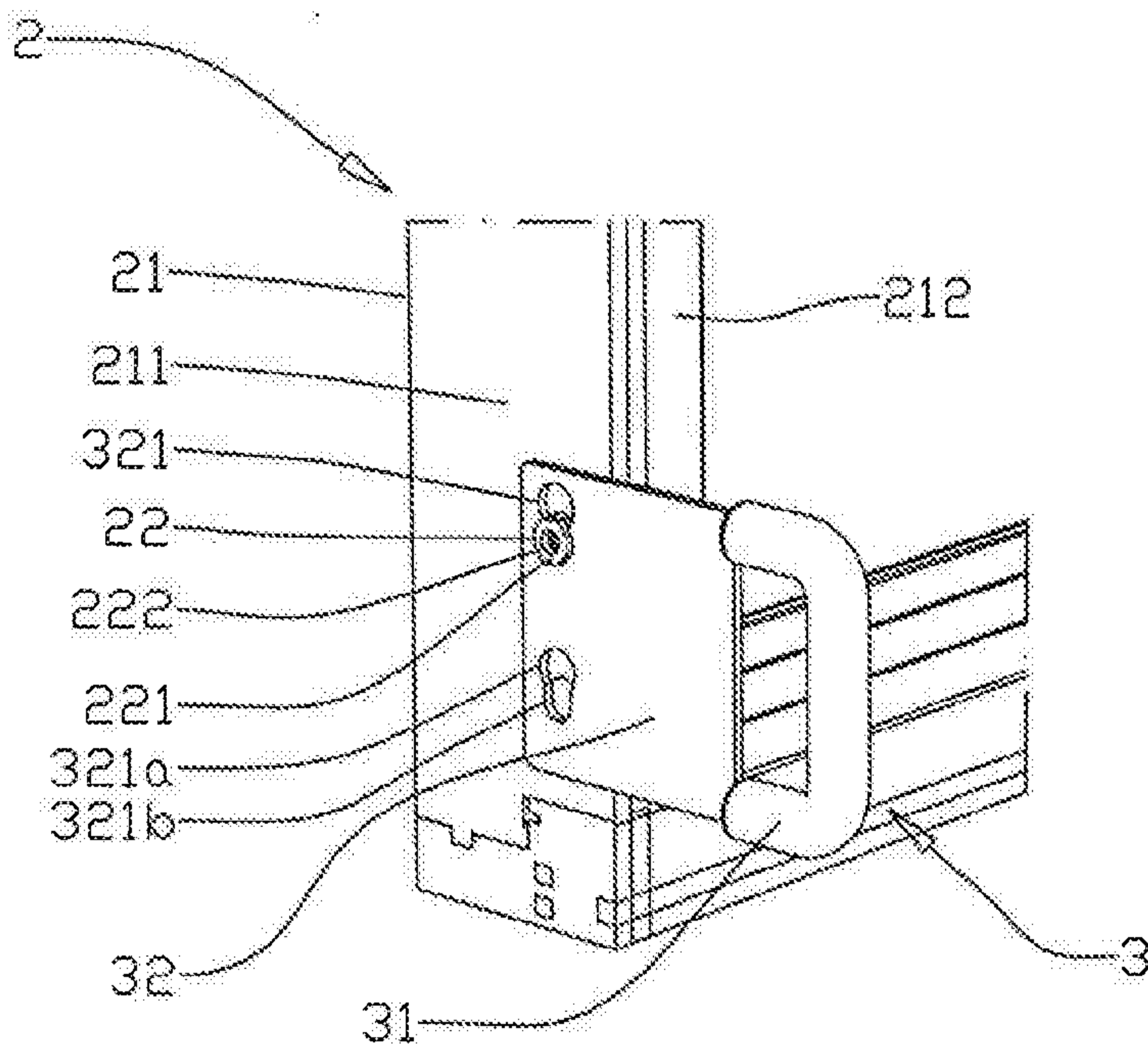

Fig. 2

(57) Abstract: A detachable carrying-handle arrangement (3) for a building component (2), especially a window or a door including a frame (21), which is to be fixed in a supporting structure (111) surrounding an opening (11) in a building structure (1) is described, the carrying-handle arrangement (3) including a grip portion (31) connected to a plate-shaped attachment portion (32) which is provided with at least two cut-outs (321) which is arranged to lockingly engage with a fixing bolt (22).

Amended description

CARRYING HANDLE FOR A BUILDING COMPONENT

The invention relates to a detachable carrying-handle arrangement for a building component, especially a window or a door including a frame, which is to be fixed to a supporting structure surrounding an opening in a building structure.

5 Building components, like windows and doors, can be both voluminous and heavy, and especially in rehabilitation, in which the transport must, to a great degree, go through entrance portions, corridors, stairways and door openings in the building under rehabilitation, building components of this kind are difficult to handle, not least because of it being difficult to find good portions which are good for gripping.

10 The invention has for its object to remedy or reduce at least one of the drawbacks of the prior art or at least provide a useful alternative to the prior art.

The object is achieved through features which are specified in the description below and in the claims that follow.

15 The invention provides a carrying-handle arrangement arranged for temporary attachment to a building component, especially to an external side face of a door frame or window frame. From a bow-shaped grip portion, there extends an attachment portion, the grip portion and the attachment portion lying substantially in the same plane. The attachment portion is provided with at least one, preferably two bolt holes for receiving fixing bolts arranged to be fixed to the building component. The bolt holes have a keyhole shape, for example, to enable the carrying-handle arrangement to
20 be slipped over the head of the fixing bolt when the head of the fixing bolt lies with a slight clearance to said side face. The fixing bolt is preferably an adjusting bolt arranged in a hole extending through the frame, the adjusting bolt being adjustable, when the building component is being fitted, into abutment against the surrounding building structure to which the building component is to be fixed. The adjustment is typically done with the use of a tool, which engages with a recess in an
25 end portion of the adjusting bolt opposite the head of the bolt. When keyhole bolt holes or the like are used in the attachment portion, the carrying-handle arrangements may remain attached to the building component until it is positioned in the building structure, for example a window being positioned in the wall opening. Then the adjusting bolts holding the carrying-handle arrangements are unscrewed a little so that the carrying-handle arrangements can be slipped off the adjusting bolts

and reused. Alternatively, the periphery of the bolt head may be arranged for engagement with a tool, for example a hexagonal head, which is gripped by an open-end spanner.

5 The attachment portion of the carrying-handle arrangement is preferably formed from a flexible plate material. Thereby, when required, the grip portion may be forced inwards towards the centre of the building component, which is an advantage where a double set of carrying-handle arrangements is used to arrange grip portions on either side of the frame. Thereby the grip portions, which are lying on the outside of the window during the installation of a window, will not be an obstruction when the window is being placed in the wall opening.

10 The carrying-handle arrangement is preferably mirror-symmetrical around a centre plane through the attachment portion, for the carrying-handle arrangement, when the bolt holes have a keyhole shape or its equivalent, to be usable in all relevant positions on the building component.

15 The invention relates more specifically to a detachable carrying-handle arrangement for a building component, especially a window or a door including a frame, which is to be fixed to a supporting structure surrounding an opening in a building structure, characterized by the carrying-handle arrangement including a bow-shaped grip portion projecting from a side edge of a plate-shaped attachment portion, the grip portion and the attachment portion laying substantially in the same plane, wherein the attachment portion is provided with at least one cut-out which is arranged to lockingly engage with a fixing bolt arranged in an external side face of the frame, and wherein the bow-shaped grip portion of the carrying-handle arrangement, when in a position of application, is projecting outwards from an external edge face of the building component, the plate-shaped attachment portion being flexible and allowing the grip portion to be forced inwards towards the centre of the building component.

25 The cut-out may include a first, in the position of application upper cut-out portion and a second, in the position of application lower cut-out portion, the second cut-out portion having a smaller transverse dimension than the first cut-out portion.

The carrying-handle arrangement may be mirror-symmetrical around a central plane through the cross section of the attachment portion. An advantage of this is that the same embodiment of the carrying-handle arrangement can be used in all relevant positions on the building component.

30 The fixing bolt may be a frame-adjustment bolt, which extends from the external side face of the frame into a through-going bolt hole, the frame-adjustment bolt being provided with an end recess arranged for engagement with an adjusting tool extending, in an active position, in through the free mouth of the bolt hole. An advantage of this is that the carrying-handle arrangement may be released after the building component has been placed in the opening, even if there is little clearance between the frame and the supporting structure.

35 The attachment portion may be elastically yielding. An advantage of this is that a grip portion pro-

jecting outwards from an external edge face of the building component can yield inwards towards the centre of the building component when the building component is to be inserted into an opening with little clearance between the frame and the supporting structure.

5 A second grip portion may be arranged on the attachment portion opposite the grip portion. An advantage of this is that the heads of the fixing bolts project minimally from the frame when the building component is so heavy that it will have to be carried by persons positioned on both sides of the building component.

In what follows, an example of a preferred embodiment is described, which is visualized in the accompanying drawings in which:

10 Figure 1 shows a side view of a building component in the form of a window partially inserted into a building structure and provided with carrying-handle arrangements according to the invention, projecting inwards from a lower side-face portion of the window frame;

15 Figure 2 shows, in perspective and on a larger scale, a first carrying-handle arrangement attached to a lower side-face portion of the window frame, a frame-adjustment bolt having been removed for the sake of exposition;

Figure 3 shows a second, opposite carrying-handle arrangement;

Figure 4 shows two carrying-handle arrangements projecting in opposite directions, arranged on the same fixing bolts; and

20 Figure 5 shows a carrying-handle arrangement provided with two grip portions.

Reference is first made to figure 1 in which the reference numeral 1 indicates a building structure provided with an opening 11 arranged to receive a building component 2, shown as a window here, and encircled by a supporting structure 111 arranged to receive the fixing means of the building component 2, several frame-adjustment bolts 22 among other things. The frame-adjustment bolts 22 are provided with bolt heads 221 and are screwed into bolt holes 214 extending through the frame 21 of the building component 2 from the external side face 211 of the frame 21, the frame-adjustment bolts 22 being provided, in end portions remote from the bolt heads, with recesses, not shown, arranged for engagement with an adjusting tool 4 inserted through bolt-hole mouths 214' in the internal side face 211' of the frame 21.

30 The building component 2 comprises an inwards facing edge face 212 and an outwards facing edge face 212'.

A carrying-handle arrangement 3 is attached to a lower portion of each external frame side face 211 by means of a selection of frame-adjustment bolts 22. Alternatively, the carrying-handle ar-

5 rangement 3 may be attached by means of ordinary fixing bolts (not shown) which do not have any other function than holding the carrying-handle arrangement 3.

Reference is now made especially to figures 2 and 3. The carrying-handle arrangement 3 includes a grip portion 31 formed as a bow-shaped handle projecting from a side edge of a plate-shaped attachment portion 32. The attachment portion 32 is provided with two cut-outs 321 arranged to receive the heads 221 of frame-adjustment bolts 22 for locking engagement. A first cut-out portion 321a is wider than a second cut-out portion 321b, the first cut-out portion 321a being arranged, in a position of application, above the second cut-out portion 321b, for example in the shape of a key-hole as shown in figure 2, in order thereby to provide space for the bolt head 221 to be passed through in the first cut-out portion 321a and prevent the bolt head 221 from passing when the frame-adjustment bolt 22 extends through the second cut-out portion 321b. It is obvious that other cut-out shapes lie within the scope of the invention as well. The distance between the cut-outs 321 is adapted to the distance between two adjacent frame-adjustment bolts 22. In figure 2, a lower frame-adjustment bolt has been removed for the sake of exposition.

15 When the carrying-handle arrangement 3 is being fitted to the external side face 211 of the frame 21, the carrying-handle arrangement 3 is oriented in such a way that the narrow portion of the cut-out 321 is facing downwards. The attachment portion 32 is brought in over the corresponding bolt heads 221, which, at this stage, are lying with a clearance to the external side face 211. The frame-adjustment bolts or the fixing bolts 22 are tightened to prevent the carrying-handle arrangement 3 from being displaced in the cut-outs 321. The operation is repeated to fix further carrying-handle arrangements 3 to other portions of the frame 21. The building component 2 has now been prepared to be moved, the carrying-handle arrangements 3 providing handles well suited for lifting the building component 2.

25 When the building component 2 has been positioned in the opening 11 of the building structure 1 and secured, the carrying-handle arrangement 3 can easily be removed by the fixing bolts 22 being loosened and the attachment portion 32 being pulled out of engagement behind the bolt heads 221. At this stage, the adjusting feature of the frame-adjustment bolt 22 particularly comes into its own, as it can be loosened by the engagement of the adjusting tool 4 with the recess, not shown, of the frame-adjustment bolt 22 via the bolt-hole mouth 214' completely independently of the clearance between the frame 21 and the adjacent supporting structure 111.

35 When required, two carrying-handle arrangements 3 may be attached to the same set of fixing bolts 22, see figure 4. Owing to the flexibility of the attachment portion 32, a grip portion 31' projecting outwards may be pressed towards the centre of the building component during the insertion of the building component 2 into its opening 11, in order not to prevent the fitting of the building component 2.

Alternatively, the carrying-handle arrangement 3 may be provided with two grip portions 31, 31'

projecting in opposite directions, see figure 5, one at each opposite side edge of an attachment portion 32, which, in this embodiment, has been extended in relation to an attachment portion 32 provided with one grip portion 31 according to figures 1-4.

Patent application no. PCT/NO2015/050002
Applicant Tom Toralv Røynestad
Frank Rob
Date February 23, 2016

A m e n d e d c l a i m s

1. A detachable carrying-handle arrangement (3) for a building component (2), especially a window or a door including a frame (21), which is to be fixed to a supporting structure (111) surrounding an opening (11) in a building structure (1), c h a r a c t e r i -
5 z e d i n that the carrying-handle arrangement (3) includes a bow-shaped grip portion (31) projecting from a side edge of a plate-shaped attachment portion (32), the grip portion (31) and the attachment portion (32) laying substantially in the same plane, wherein the attachment portion (32) is provided with at least two cut-outs (321), which are each arranged to lockingly engage with a fixing bolt (22) arranged in an external side face
10 (211) of the frame (2), and wherein the bow-shaped grip portion (31) of the carrying-handle arrangement (3), when in a position of application, is projecting outwards from an external edge face (212, 212') of the building component (2), the plate-shaped attachment portion (32) being flexible and allowing the grip portion (31) to be forced inwards towards the centre of the building component.
- 15 2. The detachable carrying-handle arrangement (3) according to claim 1, wherein the cut-out (321) includes a first, in the position of application upper cut-out portion (321a) and a second, in the position of application lower cut-out portion (321b), the second cut-out portion (321b) having a smaller transverse dimension than the first cut-out portion (321a).
- 20 3. The detachable carrying-handle arrangement (3) according to claim 1, wherein the carrying-handle arrangement (3) is mirror-symmetrical around a central plane through the cross section of the attachment portion (32).
4. The detachable carrying-handle arrangement (3) according to claim 1, wherein the fixing
25 bolt (22) is a frame-adjustment bolt extending from the external side face (211) of the frame (21) into a through-going bolt hole (214), and the frame-adjustment bolt (22) is provided with an end recess arranged for engagement with an adjusting tool (4) extending, in an active position, in through the free mouth (214') of the bolt hole (214).
5. The detachable carrying-handle arrangement (3) according to claim 1, wherein the attachment portion (32) is elastically yielding.
- 30 6. The detachable carrying-handle arrangement (3) according to claim 1, wherein a second grip portion (31') is arranged on the attachment portion (32) opposite the grip portion (31).

1/3

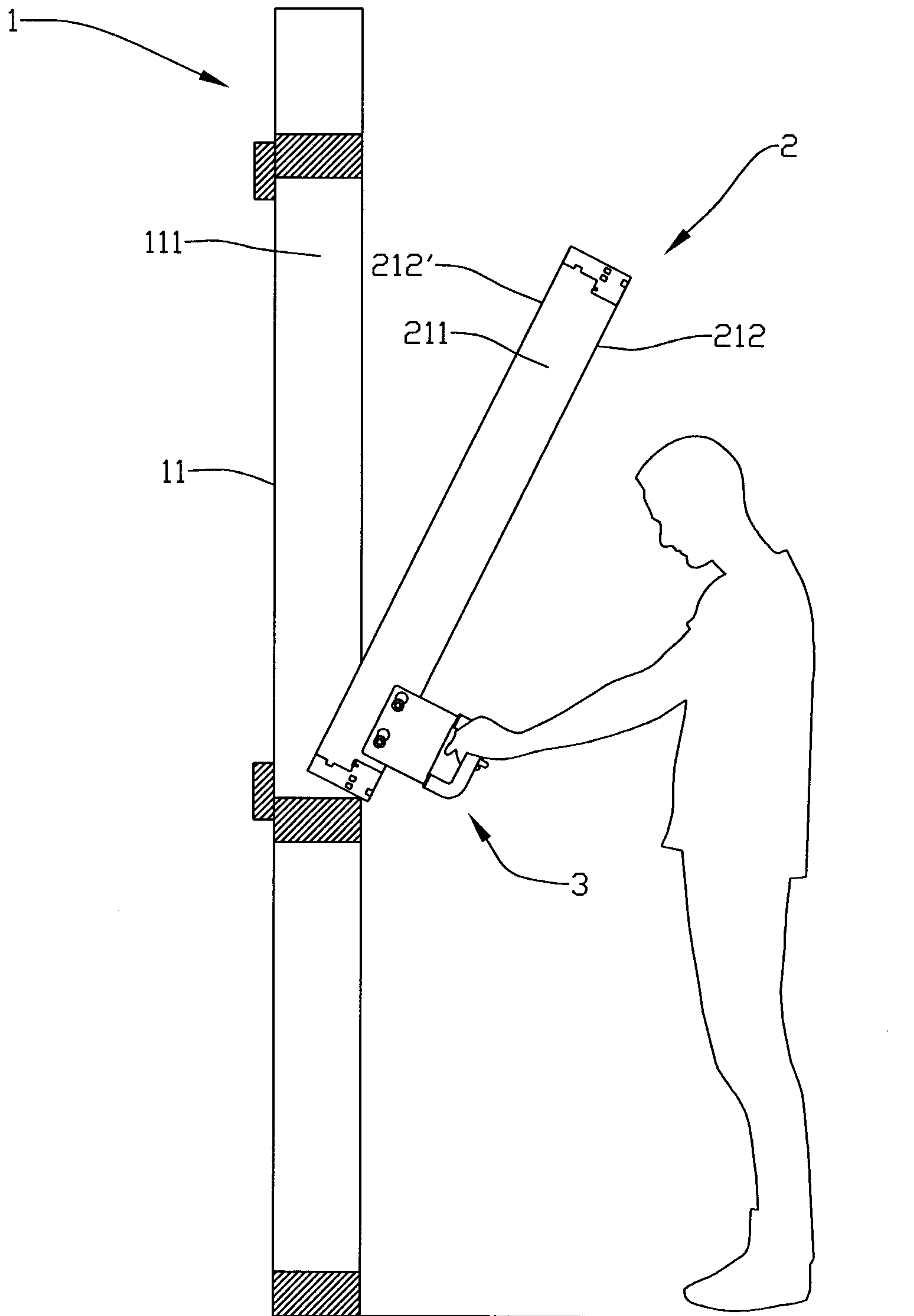

Fig. 1

2/3

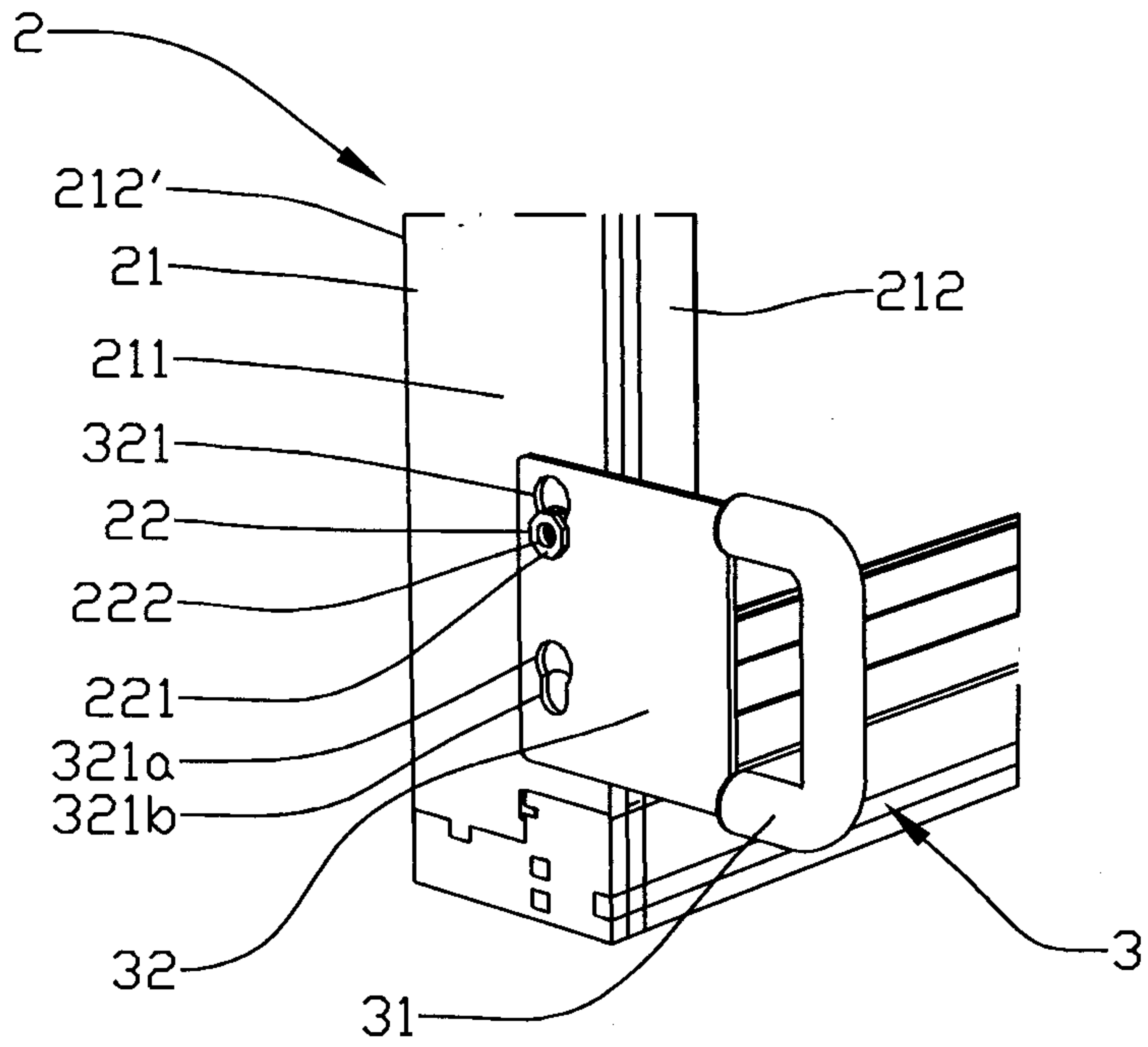

Fig. 2

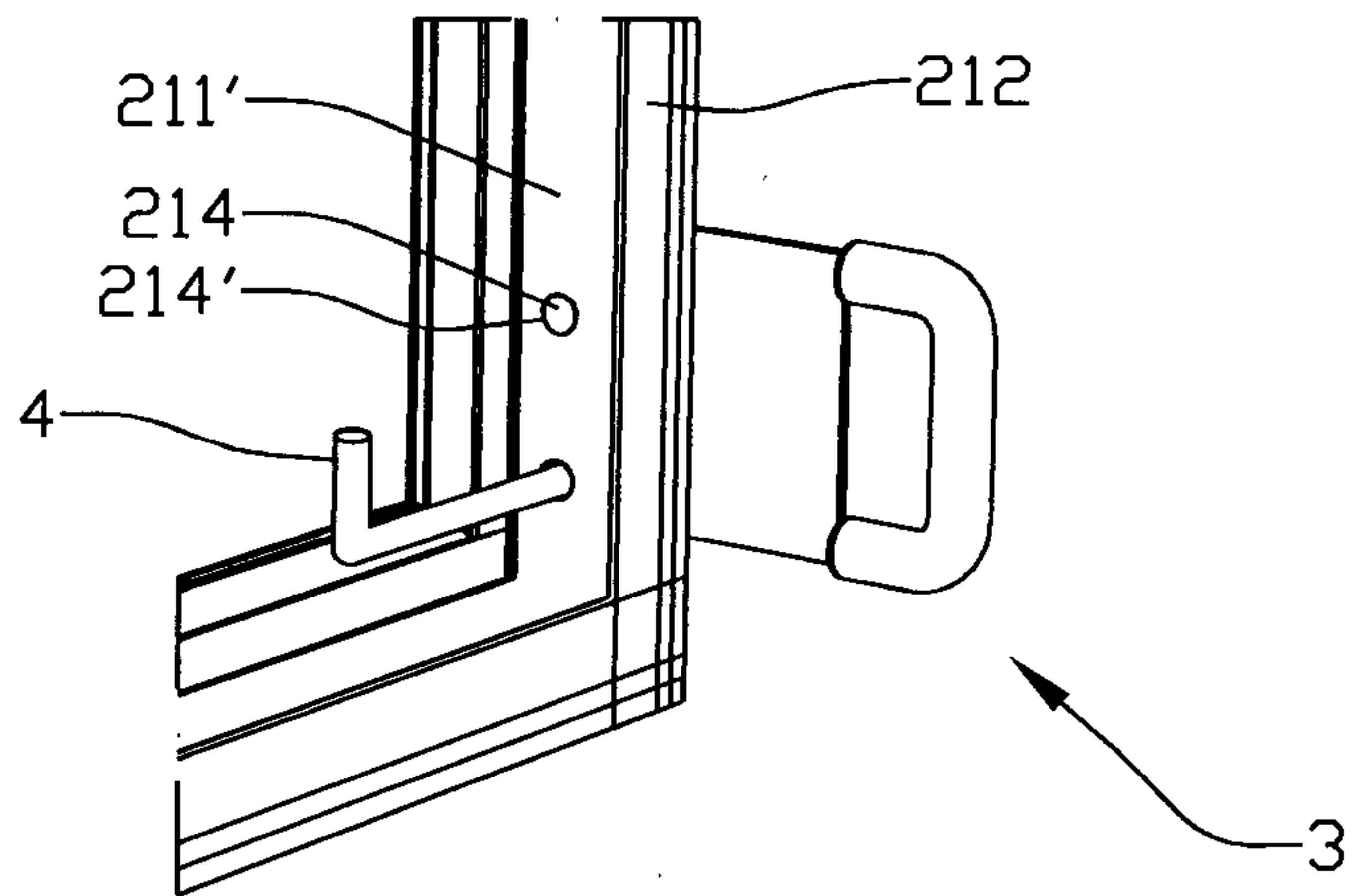

Fig. 3

3/3

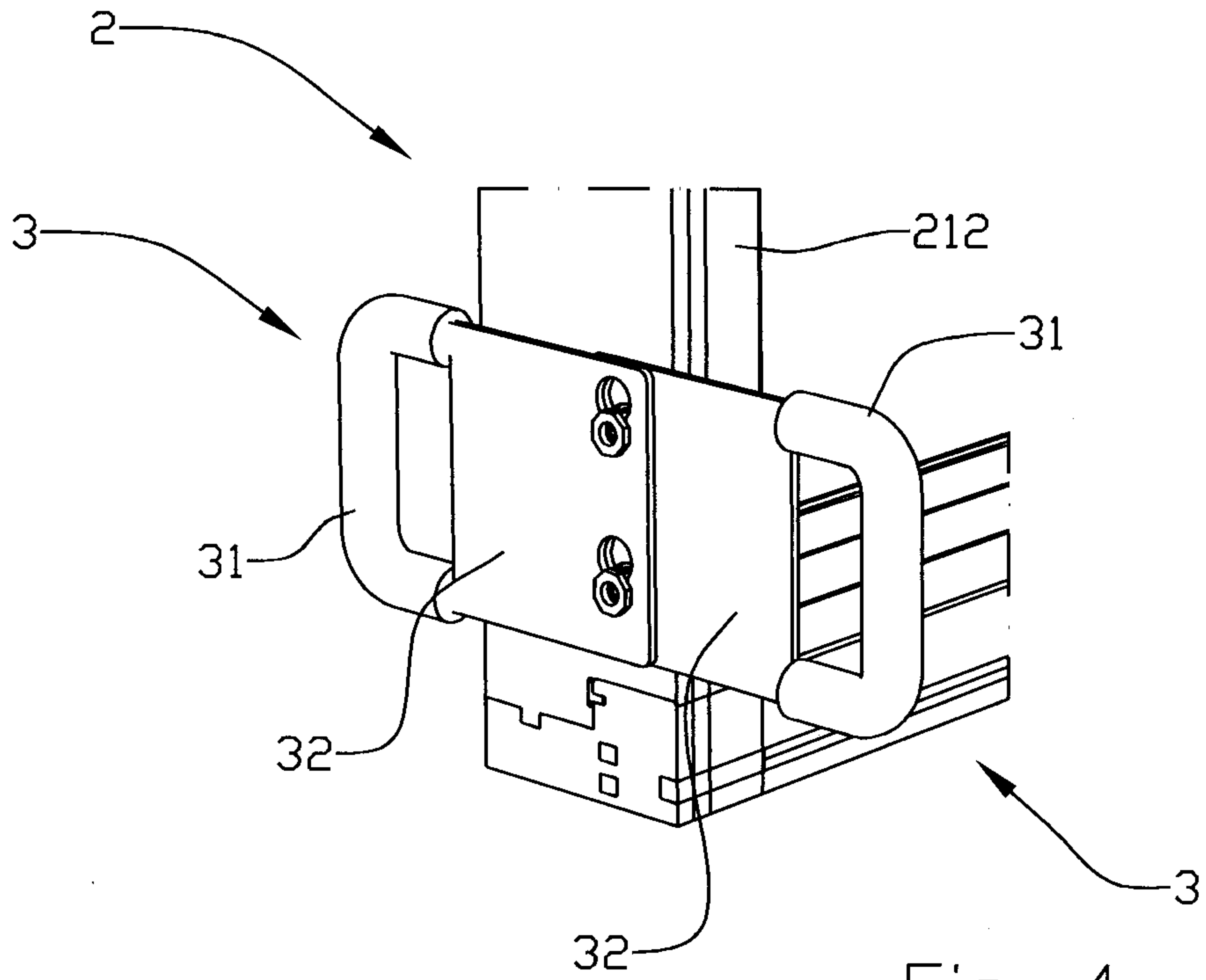

Fig. 4

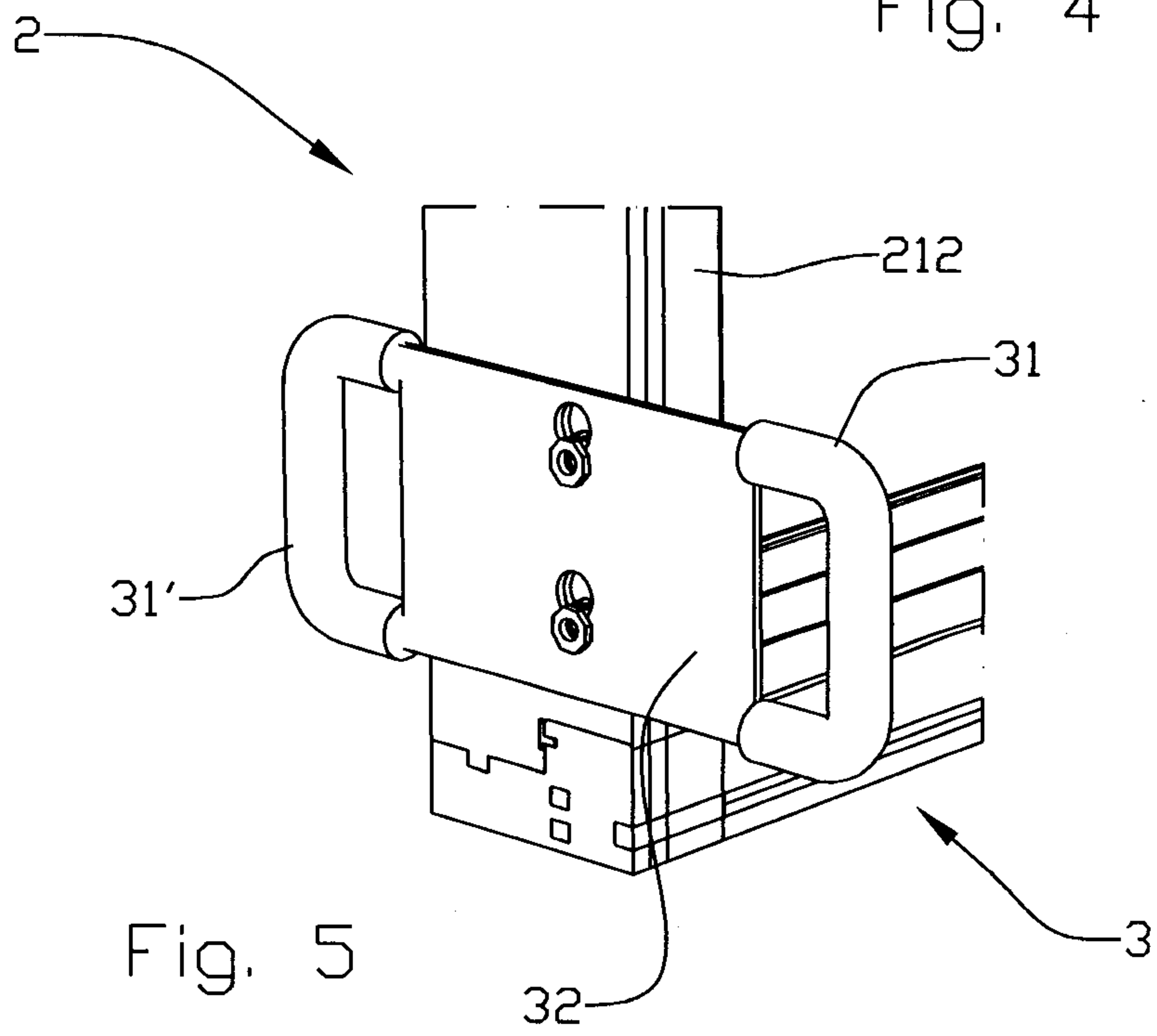

Fig. 5

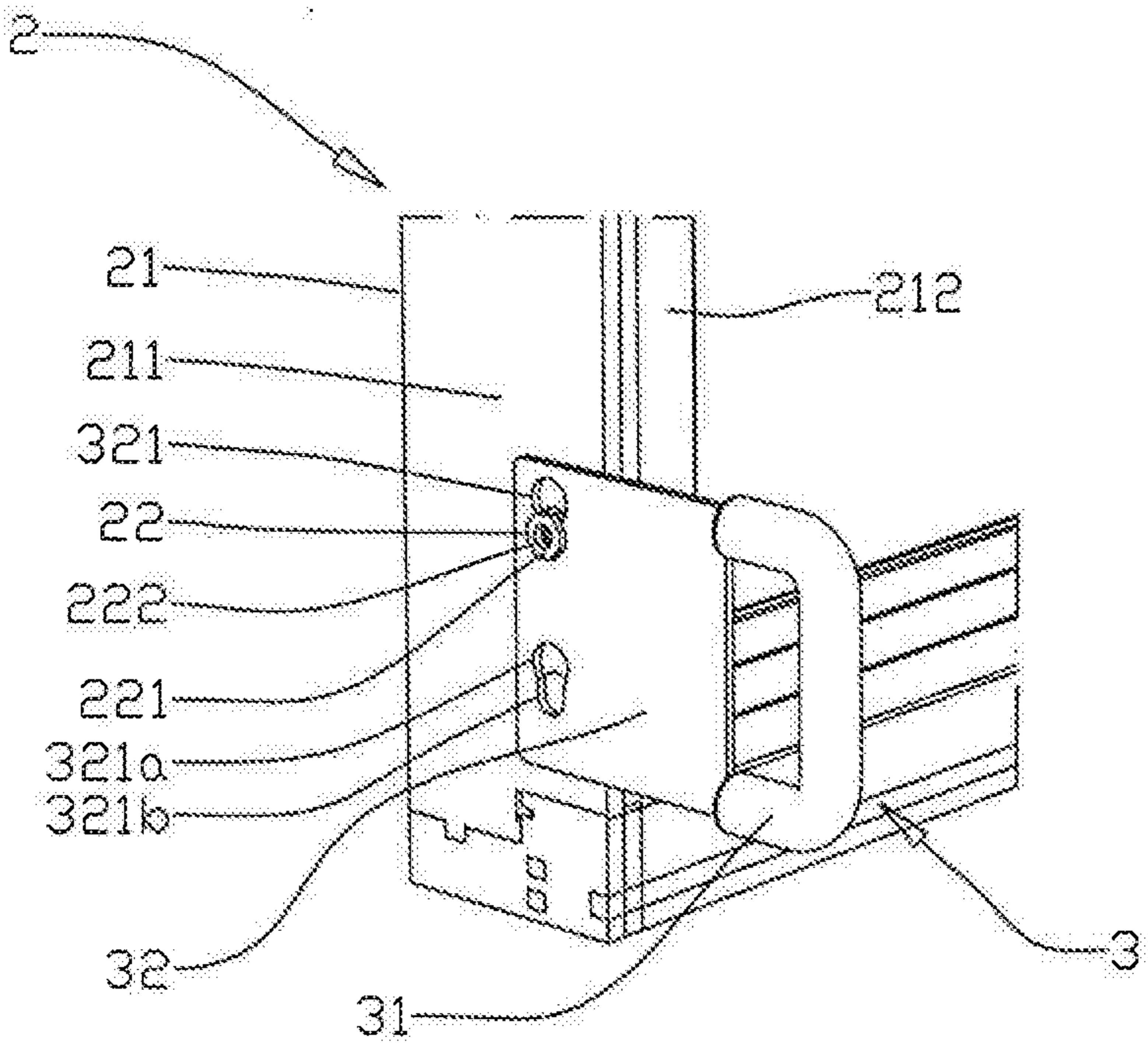

Fig. 2