

(19) World Intellectual Property Organization
International Bureau



(43) International Publication Date
25 September 2003 (25.09.2003)

PCT

(10) International Publication Number
WO 03/079582 A1

- (51) International Patent Classification⁷: **H04B 10/105**, G01S 17/74, G02F 1/35
- (74) Agents: **MITCHELL, Richard, J.** et al.; Marks & Clerk, P.O. Box 957, Station B, Ottawa, Ontario K1P 5S7 (CA).
- (21) International Application Number: PCT/CA03/00392
- (81) Designated States (*national*): AE, AG, AL, AM, AT, AU, AZ, BA, BB, BG, BR, BY, BZ, CA, CH, CN, CO, CR, CU, CZ, DE, DK, DM, DZ, EC, EE, ES, FI, GB, GD, GE, GH, GM, HR, HU, ID, IL, IN, IS, JP, KE, KG, KP, KR, KZ, LC, LK, LR, LS, LT, LU, LV, MA, MD, MG, MK, MN, MW, MX, MZ, NO, NZ, OM, PH, PL, PT, RO, RU, SC, SD, SE, SG, SK, SL, TJ, TM, TN, TR, TT, TZ, UA, UG, US, UZ, VC, VN, YU, ZA, ZM, ZW.
- (22) International Filing Date: 17 March 2003 (17.03.2003)
- (25) Filing Language: English
- (26) Publication Language: English
- (30) Priority Data: 60/365,508 20 March 2002 (20.03.2002) US
- (84) Designated States (*regional*): ARIPO patent (GH, GM, KE, LS, MW, MZ, SD, SL, SZ, TZ, UG, ZM, ZW), Eurasian patent (AM, AZ, BY, KG, KZ, MD, RU, TJ, TM), European patent (AT, BE, BG, CH, CY, CZ, DE, DK, EE, ES, FI, FR, GB, GR, HU, IE, IT, LU, MC, NL, PT, RO, SE, SI, SK, TR), OAPI patent (BF, BJ, CF, CG, CI, CM, GA, GN, GQ, GW, ML, MR, NE, SN, TD, TG).
- (71) Applicant (*for all designated States except US*): **CANADIAN SPACE AGENCY** [CA/CA]; 6767 route de l'Aéroport, Saint-Hubert, Québec J3Y 8Y9 (CA).
- (72) Inventors; and
- (75) Inventors/Applicants (*for US only*): **DUDELZAK, Alexander** [CA/CA]; 48 Sheahan Cres, Nepean, Ontario K2H 8M2 (CA). **KUZHELEV, Alexander** [CA/CA]; 8-2265 rue Brebeuf, Québec J4J 3P9 (CA). **NOVIKOV, Alexander** [CA/CA]; 309-5765 Cote St-Luc, Hampstead, Québec H3X 2E9 (CA). **PASMANIK, Guerman** [CA/CA]; 311-1875 Steels Ave W, Toronto, Ontario M3H 5T7 (CA).

Published:
— with international search report

For two-letter codes and other abbreviations, refer to the "Guidance Notes on Codes and Abbreviations" appearing at the beginning of each regular issue of the PCT Gazette.

(54) Title: METHOD OF ESTABLISHING COMMUNICATION THROUGH FREE SPACE BETWEEN A PAIR OF OPTICAL COMMUNICATIONS DEVICES

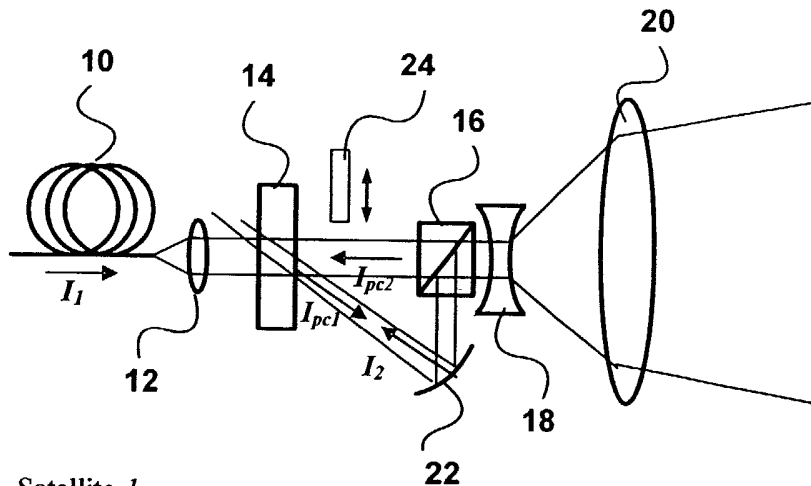

Satellite 1

(57) Abstract: A method is disclosed for establishing communication through free space between a pair of optical communication devices. A divergent beam is transmitted from each of the optical communication devices toward the other. A portion of the received divergent beam is used to create a phase conjugated beam that is returned to the other device. A diffraction grating is dynamically recorded at each devices so as to establish a bi-directional self-tracking optical link between the devices.

WO 03/079582 A1

METHOD OF ESTABLISHING COMMUNICATION THROUGH FREE SPACE
BETWEEN A PAIR OF OPTICAL COMMUNICATIONS DEVICES

FIELD OF THE INVENTION

This invention relates to the field of optical communications, and in particular, to a method and an apparatus for establishing optical communication through free space between a pair of optical communication devices. The invention is, for example, applicable to optical communication between orbiting satellites.

BACKGROUND OF THE INVENTION

When optical communication is established between satellites, some means must be found to keeping the optical beam pointing at the target in order for communications to take place. Existing optical beam control techniques limit the capabilities and performance of spatial and temporal light modulators (such as in pointing, deflecting, cross-switching and other systems for optical telecommunications, artificial vision and other electro-optical/photonics applications in space and on the ground). For example, one of the main challenges in achieving ultra-high bit-rates for optical inter-satellite (OISL) and other communication links has been precision beam control.

Communication inter-satellite, satellite-to-ground, and ground-to-satellite cross-links are currently provided by radiofrequency (RF) transceivers. While RF technology is technically mature, these systems suffer from certain shortcomings. Duplex RF systems come at generally high cost, therefore simplex systems are widely employed at a price of allowing communication in one direction at a time. In addition, the frequencies available for RF satellite communication are currently very limited. Finally, RF systems offer limited rates for data transmission.

High data rate station-to-station optical communication through free space is afforded by the use of a very narrow optical beam. Acquisition and tracking of the narrow beam is problematic in that the beam must be pointed at a remote transceiver with microradian accuracy. Optical beams of sufficient brightness are typically tens of microradians in diameter, while the corresponding requirement for RF beam widths is generally on the order of one to two degrees.

Prior optical communications concepts relied on power consuming optical beacons for initial acquisition. An alternative approach involves scanning of a diffraction limited transmit beam over the region of pointing uncertainty in order to illuminate the remote transceiver. Since the narrow angle transmit beam of both

transceivers must be scanned and finally co-aligned (while taking into account the point-ahead angle), the acquisition process is very time consuming making it a costly solution.

Other methods using electro-mechanical deflection devices rely on the concept of each transceiver autonomously tracking the image of the other's transmit beam. Many optical communications systems incorporate an expensive charge coupled device (CCD) image sensor or an image-splitting device followed by a quadrant detector. The principle of operation of such system can be briefly explained as follows. A separate pointing and tracking signal is used as a "beacon," for determining the amount of mechanical steering. A lens focuses an incoming beam onto a CCD-matrix in order to obtain angular coordinates of the transmitter. The discrepancy signal between the directions of the incoming and outgoing beams controls a motorized mirror that moves, making the beams coincide. Since the dynamic range of the pointing error is large (e.g., 1,000:1), a single-stage tracker is not feasible, especially when the communication data rates are considered. Therefore, a coarse-fine implementation with dual detector complements has been the usual approach. Furthermore, the as communicating devices are moving relative to each other, to achieve efficient functioning of such a modulator it is necessary to predict positions of the transmitter and the receiver precisely enough that the narrow beam of the communication laser does not miss the remote target moving along not that precisely defined orbit. Relative to optical steering systems, these systems are typically complicated and expensive increasing the payload weight and the signal acquisition time.

From the mid 1980s to date, the OISL transmission rate has grown from 1 Mbps to 50-1200 Mbps [3-5] and now promises to reach 2.5 Gbps and higher. Optical cable links now require light switches/deflectors capable of working with terabit transmission rates. Free-space communication links also use fibers on both the transmitting and receiving ends. The electro-mechanical beam-deflecting techniques fundamentally limit a link performance to the Gbps range. This causes serious difficulties with directing a received optical signal to a single-mode telecommunication fiber for further DWDM (Dense Wavelength Division Multiplexing). In turn, it presents one of the most important difficulties making viable a substantial increase in the number of multi-wavelength channels in the same fiber.

SUMMARY OF THE INVENTION

Thus, there has been a need in the art of free space optical communications for an all-optical method of beam control and automatic coupling of two distant laser sources.

The present invention adopts a novel, all-optical approach in beam control/deflection/tracking techniques based on combination of optical wave phase conjugation and optical dynamic holography. The advantage of this approach is that it allows achieving automatic, self-controlled coupling of beam emitters and receivers (e.g. optical fibers or distant telecommunication satellites). The proposed approach is based on using nonlinear optical materials, in which the so-called Double Phase Conjugation (DPC, also known as mutual phase conjugation, or double-pumped phase conjugation) can be realized with low light intensity. Combining the DPC phenomenon with dynamically recorded diffraction grating in these materials allows a bi-directional optical link to be established between a transmitter and a receiver with an automatic tracking feature. The concept eliminates the need for ultra-precise mechanical steering elements as well as complicated positioning and addressing computing. One of the important results is the potential increase in the performance levels of both the ground optical fiber and intersatellite communication links.

Accordingly in a first aspect the present invention provides a method of establishing communication through free space between a pair of optical communication devices, comprising transmitting a divergent beam from each of said optical communication devices toward the other of said optical communication devices; receiving a portion of said divergent beam at each of said optical communication devices transmitted from the other of said optical communication devices; returning a beam phase conjugated with said received portion of said divergent beam from each of said optical communication devices to the other of said optical communication devices; and dynamically recording a diffraction grating at each of said optical communication devices to establish a bi-directional self-tracking optical link between said pair of optical communication devices.

Phase-conjugate optics is a branch of nonlinear optics that deals with the generation, propagation, and application of phase-conjugated beams of light. Considering a light beam as the motion of a family of wave fronts in space, the phase-conjugate of that light wave has exactly the same set of wavefronts as the initial wave, but it moves in the opposite direction. Consequently, a phase-conjugated beam

can be considered a time-reversed replica of an incident beam, capable of retracing the path of the incident beam. Phase conjugation is discussed in "Optical Phase Conjugation", Academic Press, New York, 1982, R.A. Fisher ed., the contents of which are herein incorporated by reference.

The most common processes to generate a conjugate of a given wave, include: stimulated Brillouin scattering, four-wave mixing, three-way wave mixing, or photon echoes. However, it is now understood that virtually any nonlinear optical effect can be used for this purpose, including photorefraction. The photorefractive effect occurs in photorefractive crystals, such as barium titanate (BaTiO_3) and strontium barium niobate (SBN).

When a photorefractive crystal is illuminated with two mutually coherent laser beams an interference fringe pattern is formed within the crystal. The fringe pattern causes a charge separation, which creates an electric field that, in turn, induces a change in the index of refraction due to Pockel's effect. This results in a volume index grating that affects the propagation of the light beams in the crystal (phase conjugation) and allows the exchange of energy between the beams (beam coupling). A phase-conjugated light wave is produced by a readout of the same frequency, counterpropagating to the mutually coherent write beam which diffracts off the index grating (volume hologram).

Phase conjugation technology is currently used to correct optical signal distortions presented by the laser light source due to thermal effects or non-ideal optics and light guiding systems. It could be used to correct aberrations imposed on a communication signal by atmospheric conditions, such as turbulence, diffraction, thermal blooming and aerosol scattering.

Double phase conjugation (DPC) is especially promising for use in bi-directional optical links because it provides mutual conjugation of two incoherent laser beams. The advantage of using DPC is that it allows achieving automatic, self-controlled coupling of beam emitters and receivers (e.g. optical fibers or distant telecommunication satellites). Double phase conjugation is discussed, for example, with reference to photorefractive crystals in "Phase Conjugation", Nauka, Moscow, 1985, N. Ya Zeldovich, N.F. Pilipetskii, and V.V. Shkunov, the contents of which are herein incorporated by reference.

In another aspect the present invention provides an optical communication device for use in a free space optical communications system comprising a pair of

such devices, said optical communication device comprising an input element for generating an input beam carrying information to be transmitted to another optical communications device through free space; a non-linear optical element in the path of said input beam for dynamically recording a diffraction grating; an output element for generating a divergent output beam from said input beam; and an optical path to said non-linear optical element for an incoming beam generated in said other optical communications device; whereby a second beam phase conjugated to said incoming beam is generated in said non-linear element and returned to said other optical communications device.

Thus, the invention provides a novel, all-optical approach in beam control/deflection/tracking techniques based on combination of optical wave phase conjugation and optical dynamic holography. Such an approach is suitable for achieving automatic, self-controlled coupling of beam emitters and receivers (e.g. optical fibers or distant telecommunication satellites). The method and the apparatus is proposed, both based on using nonlinear optical materials, in which the so-called Double Phase Conjugation (DPC) process can be realized with low light intensity. Combining the DPC phenomenon with dynamically recorded diffraction grating in these materials allows the establishment of a bi-directional optical link between an optical transmitter and a receiver with an automatic tracking feature. The invention can eliminate the need for ultra-precise mechanical steering elements as well as complicated positioning and addressing computing. An important result is the potential increase in the performance levels of both the ground optical fiber and intersatellite communication links.

BRIEF DESCRIPTION OF THE DRAWINGS

The invention will now be described in more detail, by way of example only, with reference to the accompanying drawings, in which:-

FIG. 1a is a diagrammatic view of a DPC steering module of a holographic/phase conjugation optical transceiver;

FIG. 1b is diagrammatic view of the OISL communications system illustrating the interaction of two satellite terminals;

FIG. 2 is a vector diagram of wave interaction in a nonlinear medium; and

FIG. 3 is the plot of the threshold coupling constant L as a function of pilot beam intensity ratio for a system in accordance with one embodiment of the invention.

DESCRIPTION OF THE PREFERRED EMBODIMENTS

Figures 1a and 1b illustrate how DPC may be used to link two distant laser on respective satellites 1, 2. A communication fiber 10 is used for carrying the communication signal providing information transfer and in addition a pilot (beacon) signal. It is assumed that both signals are propagating in the same fiber 10, which will allow for precise matching of the directions and transverse structures of these two optical beams. The beam I_1 referred to below is the summed composition of both the pilot and signal beams.

The summed composition of pilot and signal beams I_1 is collimated at the output of the fiber 10 in a collimator lens 12 and passed through the nonlinear medium 14 that exhibits third-order optical non-linearity, such as a BTiO_3 or SBN photorefractive crystal. Third-order optical non-linearity means that the refractive index is depend on intensity of the light. Thus, an interference pattern of two coherent optical waves will induce a holographic grating.

A portion of the beam I_1 is passed through the beam splitter 18 and through the input/output telescope comprising two lenses (or curvature mirrors) 18 and 20 providing sufficient output divergence of the beam I_1 to cover the uncertainty in the position of the other satellite location (satellite B). The central direction of the pilot beam I_1 is oriented toward the predicted position of the satellite 2. This preliminary orientation can be implemented by rotation of the whole tracking system or by steering a mirror installed at the exit of the tracking system. The interception of the satellite 2 would be ensured by an appropriate divergence of the beacon beam. If the uncertainty of satellite 2 location is too large, a preliminary scanning may be necessary.

The terminal of satellite 2 features a matching transceiver producing similar pilot beam I_2 . Part of this pilot beam I_2 , is received by the aperture of the input/output telescope of satellite 1 (lenses 20, 18) and is divided by the beam splitter 16. Part of the divided beam I_2 is passed to a curvature mirror 22, from which it is reflected and focused on the nonlinear medium 14. If the intensities of the two pilot beams I_1 and I_2 in the nonlinear medium 14 are sufficient, the formation of phase-conjugated beams is induced.

Two phase-conjugated beams are produced by means of the DPC process as described in "D. Udaian, K. S. Syed, R. P. M. Green, D. H. Kim, and M. J. Damzen, "Transient modelling of double-pumped phase conjugation in inverted Nd:YAG", Optics

Communications, 133, pp. 596-604, 1997.", the contents of which are herein incorporated by reference.

This phenomenon can be explained in the following way. Let us assume that two optical waves with complex amplitudes of electric field A_1 and A_2 enter the nonlinear medium 14 from opposite sides (Fig. 2). Each optical wave produces scattering waves propagating in different directions. The scattering waves interfere with each initial wave producing holograms enabling their amplification due to reflection of initial waves from the holograms. The scattering waves that are phase conjugated to each initial wave A_{pc1} and A_{pc2} get much more amplification because they use the same hologram. The joint hologram plays the role of providing positive feedback in the growth of two counter-propagating scattering processes that lead to parametric generation of phase conjugated waves.

Since the DPC process is caused by the formation of a joint hologram that reflects each pilot beam towards the other, this hologram may be used for reflection of communicating beams. The fact that the signal beam and the pilot beam have the same direction and structures is significant since it ensures that both beams reflected from the hologram are phase conjugated to the incoming beams. Thus conjugated part of the outgoing signal beam I_1 will be ideally coupled to the single-mode communication fiber located on the other satellite 2.

The feasibility of this approach using available nonlinear optical materials can be demonstrated. The main parameter critical for realization of DPC is nonlinear optical gain γ that characterizes energy transfer from a powerful pilot beam to phase conjugated beam starting from the scattering level. According to Udaian *supra*, DPC may be realized when the following threshold condition is satisfied:

$$s = \tanh\left(\frac{\gamma L}{4} \cdot s\right) \quad (1)$$

$$s = \left| \frac{1-q}{1+q} \right| \quad (2)$$

wherein, L is the nonlinear medium length, and $q=I_1/I_2$ is the intensity ratio of the beams I_1, I_2 . In practice, case of interest arises when q is much more than unity.

Indeed, only small part of pilot beam I_2 will reach the aperture of the satellite 1 large area of location uncertainty of this satellite must be covered.

The plot of the threshold coupling constant γL as a function of beam intensity ratio is shown in Fig. 3. In photorefractive crystals, such as BTiO_3 or SBN, the exponential gain coefficients γ can be as large as 20 cm^{-1} in the visible range at several mW power of interacting beams as described in: "P. Yen, "Introduction to photorefractive nonlinear optics", A Willey-Interscience publication, New York, 1993," "E. J. Sharp, W. W. Clark III, M. J. Miller, G. L. Wood, B. Monson, G. J. Salamo, and R. R. Neurganokar, "Double phase conjugation in tungsten bronze crystals", Applied Optics, 29, pp. 743-749, 1990," and in Udaian *supra*. Thus DPC at beam intensity ratio 10^3 - 10^4 (put 10^3) is reliable in such crystals with a length of 1 cm. Further increase of intensity ratio q is not reasonable since parasitic scattering and reflections from output optics may occur in this case.

The focusing of the beam I_2 onto the photorefractive crystal is assumed to give a beam diameter d_2 varying from $2.5 \mu\text{m}$ to $1400 \mu\text{m}$ along all crystal length (put $d_2=100 \mu\text{m}$). For the outgoing beam I_1 , the diameter $d_1=1.5 \text{ cm}$ is suggested. This diameter ratio ensures a high fidelity of phase conjugation for the outgoing beam, enabling high efficiency of coupling of outgoing beam and communication fiber in satellite 2 as described in: "P. Gunter and J.-P. Huignard eds., "Photorefractive materials and their applications I", Shpringer-Verlag, Berlin, 1988.", the contents of which are herein incorporated by reference.

Assuming an aperture for the output/input telescope $D_{tel}=25 \text{ cm}$ and equal powers of both pilot beams at the exit of each satellite, the diameter of the pilot beam I_2 at the location of satellite 1 can be estimated in the following way:

$$D = \frac{d_1}{d_2} \cdot D_{tel} \sqrt{q} \quad (3)$$

This estimate gives us $D \approx 1 \text{ km}$. For OISL between low-orbit satellites at distances of about 1000 km, this will correspond to covered angular uncertainty θ_{cover} of about 1 mrad. This value is not far from typical angular uncertainty that may be from 1.4 mrad to 7 mrad.

The DPC threshold is achieved. In Figure 1b, I_1 and I_2 represent the outgoing beams from satellites 1 and 2 respectively. I_{pc1} and I_{pc2} represent the two phase conjugated beams returned from the corresponding satellites. This results in further growth of the diffraction efficiency of a joint holographic grating. This may be explained with reference to the example of satellite 1 (Figs. 1a and 1b). Contrary to the initial stage of the DPC process, where the grating was initially written by the pilot beam I_2 and its spontaneous scattering and small seeding toward phase conjugated mode, the phase conjugated beam I_{pc2} now works as a strong seed for the hologram writing process. Due to such seeding, the hologram effects additional recording and its diffraction efficiency is increased, enabling an increase in the power of the phase conjugated beams. Thus, now the feedback between two crystals located on the two satellites 1 and 2 is self-induced, and the two crystals work as one integrated DPC system. This feedback turns out to be positive as the power of the phase conjugated beams and holograms reflectivity increases.

The growth is limited by depletion of pilot beams in the area of their intersection. If the angle of pilot beams intersection (Figs. 1a and 1b) is about 45° , the area of their intersection is about $0.14 \text{ cm} \times 1.5 \text{ cm}$, that is 10% of the total square of pilot beam I_1 . Assuming full depletion of the pilot beam I_1 in that area, 10% of its power (and as consequence 10% of power of communication beam) may be transferred to the phase conjugated beam. However, only part of this power will reach the communication channel on satellite 2 because of non-perfect phase conjugation. The phase conjugation error is based on the fact that only small part of pilot beam is conjugated due to finite of incoming/outgoing aperture. This limitation may be expressed as limitation of divergence θ_{pc} of conjugated beam:

$$\theta_{pc} = \lambda D_{tel} \quad (4)$$

where λ is wavelength, assuming $\lambda=500 \text{ nm}$ for θ_{pc} obtain $2 \text{ } \mu\text{rad}$. This gives a spot size for conjugated beam at the receiver location $\sim 2 \text{ m}$, that is 8 times more than the receiver aperture. Such aperture losses decrease the transmission coefficient from 10% to 0.15%.

Thus, the basic steps in the operation of this system may be summarized in the following phases.

1. Orientation of the pilot beams toward the predicted satellite locations.
2. Build up of the holographic gratings, enabling the DPC in each satellite.
3. Build up of the inter-satellite optical feedback, resulting to steady-state reflectivity of the holograms.
4. Information transfer.

As the hologram reaches its steady-state and the information transfer is activated. The transfer is not interrupted as a result of relative movement of the satellites so long as both satellites keep each other in field of view (in the angle of θ_{cover}). In practice, this means that the hologram is continuously correcting (not fully rewritten, but affected by small correction) by changing of pilot beams directions. From this point, the speed of angular tracking can be estimated in the following form:

$$\varphi = \frac{\theta_{cover}}{\tau} \quad (5)$$

where τ is time of grating build up. In the example of photorefractive crystals BTiO_3 or SBN the time of grating build up lies in the range of 50-200 ms. Thus for φ , we get an estimate of 5-20 mrad/s. If the linear relative speed of the satellites is in the order of 8 km/s at distance between them 1000 km, this gives limitation on φ in order of 8 mrad/s, which is in reliable range. Thus, the use of DPC concept in OISL seems is feasible.

The critical parameters for materials needed for the realization of DPC approach in OISL are nonlinear gain $\gamma \geq 20 \text{ cm}^{-1}$ and grating build up time $\tau \leq 50 \text{ ms}$. As mentioned above, these parameters can be realized in a number of photorefractive crystals in the visible range. However, in the preferred case this system should be compatible with on ground fiber communication network. The operating wavelength of the OISL should be in the range of 1.3-1.6 μm .

The last requirement produces the main challenge since the nonlinear medium should be sensitive in that range. Promising results concerning DPC in that range have been observed with Cr-, Fe-, and V- doped cubic semi-insulating crystals, such as CdTe, GaAs, and InP. However, their use should be accompanied by the application of a high voltage (to provide a dc field as much as 20 kVcm^{-1}). Such as high field is

unacceptable in a vacuum satellite environment. Multi-composite polymeric photorefractive materials and doped liquid crystals may be suitable for this purpose. A nonlinear gain up to 1000 cm^{-1} has been already demonstrated in such materials in visible range. See "Double-phase-conjugation mirror in CdTe:V with elimination of conical diffraction at $1.54 \mu\text{m}$ ", *Optics Letters*, 20, pp. 937-939, 1995. The possibility of expanding the area of their applicability to IR range is quite reliable due to the high flexibility in the variation of their properties by chemical development of new materials and components.

In an alternative embodiment, it is possible to use a four-wave mixing architecture for the DPC. In Figures 1a and 1b, a partial reflective mirror 24 is inserted to provide backward reflection of the pilot beam I_1 . In this case, there is no threshold for hologram formation because it is written by incoming pilot beam I_2 and supporting beam I_1' (backward reflection of pilot beam I_1). This has much greater intensity than scattering beam and seeding I_{pc2} in case of a parametric DPC (Figs. 1a and 1b without mirror 24). High values of reflectivity can be achieved when the coupling coefficient (or gain in photorefractive crystals) $|\gamma| \approx 1$. This can be realized in a number of materials, for example, in liquids with thermal nonlinearity as described in "A photorefractive polymer with high optical gain and diffraction efficiency near 100%", *Nature*, 371, pp 497-500, 1994, the contents of which are herein incorporated by reference. However, instead of stringent requirements for nonlinear medium, there are stringent requirements for the laser sources. The main challenge here is to provide coherence of the two pilot beams from separate satellites. In reality, this can be achieved if the pilot beams have pulse periodic structure, and the pulse duration τ_p is less than the inverted frequency difference of the two pilot waves. This requires a pulse duration in order of 0.1-1 ns. This presents an additional challenge in directing of the pilot beam into the single-mode fiber because of optical break down, stimulated Raman scattering in the fiber and other undesirable effects arising at pulse energies in order of hundreds of μJ . In principle, the communication signals may be adjusted with pilot beam in free space (not by directing them in the same fiber), but in this case their directions and especially transverse structures will not be the same, resulting in reflection of the communication signal from the hologram in the wrong direction with a structure that is not phase conjugated.

It will be seen that in accordance with the principles of the invention, the use of the DPC phenomenon (either in parametric or in four-wave mixing variants) can avoid the

need for heavy and slow high-precision mechanics and shows promise in achieving data rates as high as those achievable with on-ground fiber optic communication.

Claims:

1. A method of establishing communication through free space between a pair of optical communication devices, comprising:
 - transmitting a divergent beam from each of said optical communication devices toward the other of said optical communication devices;
 - receiving a portion of said divergent beam at each of said optical communication devices transmitted from the other of said optical communication devices;
 - returning a beam phase conjugated with said received portion of said divergent beam from each of said optical communication devices to the other of said optical communication devices; and
 - dynamically recording a diffraction grating at each of said optical communication devices to establish a bi-directional self-tracking optical link between said pair of optical communication devices.
2. A method as claimed in claim 1, wherein said divergent beams are composite beams comprising a pilot beam for establishing double phase conjugation and a signal beam for transferring information between said optical communication devices.
3. A method as claimed in claim 2, wherein said phase conjugated beams are formed in non-linear optical device in which said diffraction gratings are recorded.
4. A method as claimed in claim 3, wherein said non-linear optical device is a photorefractive crystal.
5. A method as claimed in claim 4, wherein said photorefractive crystal is selected from the group consisting of BTiO_3 or SBN.
6. A method as claimed in claim 4, wherein the operating wavelength of the optical communication devices is in the range 1.3 – 1.6 μm and said photorefractive crystal is selected from the group consisting of Cr-, Fe-, and V- doped cubic semi-insulating crystals.
7. A method as claimed in claim 6, wherein said photorefractive crystal is selected from the group consisting of CdTe, GaAs and InP crystals
8. A method as claimed in any one of claims 3 to 7, wherein said divergent beams originate from respective source beams and are passed through a beam diverger/collimator at the output of each optical communications device.
9. A method as claimed in claim 8, wherein said source beams are first passed through said non-linear device and a beam splitter, such that an incoming non-phase

conjugated beam is separated by said beam splitter and directed toward said non-linear device by a mirror.

10. A method as claimed in claim 9, wherein said non-linear device returns a beam phase conjugated with said incoming beam via said mirror and said beam splitter, and an incoming phase conjugated beam passes through said phase splitter to said non-linear device.

11. A method as claimed in claim 10, wherein a partially reflective mirror is inserted in said source beams between said non-linear device and said beam splitter to provide partial backward reflection of said pilot beams and thereby provide four-wave mixing.

12. An optical communication device for use in a free space optical communications system comprising a pair of such devices, said optical communication device comprising:

- an input element for generating an input beam carrying information to be transmitted to another optical communications device through free space;

- a non-linear optical element in the path of said input beam for dynamically recording a diffraction grating;

- an output element for generating a divergent output beam from said input beam;

and

- an optical path to said non-linear optical element for an incoming beam generated in said other optical communications device;

whereby a second beam phase conjugated to said incoming beam is generated in said non-linear element and returned to said other optical communications device.

13. An optical communication device as claimed in claim 12, wherein dynamic recording of said diffraction grating in said non-linear optical element induces modulation of said second beam phase conjugated to said incoming beam generated in said other optical communication device by said input beam carrying information to be transmitted to said other communication device.

14. An optical communication device as claimed in claim 13, wherein said non-linear optical device is a photorefractive crystal.

15. An optical communication device as claimed in claim 14, wherein said photorefractive crystal is selected from the group consisting of BTiO_3 or SBN.

16. An optical communication device as claimed in claim 14, wherein the operating wavelength of the optical communication devices is in the range 1.3 – 1.6 μm and said

photorefractive crystal is selected from the group consisting of Cr-, Fe-, and V- doped cubic semi-insulating crystals.

17. An optical communication device method as claimed in claim 16, wherein said photorefractive crystal is selected from the group consisting of CdTe, GaAs and InP crystals.

18. An optical communication device as claimed in any one of claims 12 to 17, further comprising a beam splitter located between said non-linear optical.

19. An optical communication device as claimed in claim 18, further comprising a mirror for reflecting an incoming beam toward said non-linear optical element.

20. An optical communication device as claimed in claim 19, further comprising a partially reflective mirror between said non-linear element and said beam splitter to initiate four-wave mixing.

21. An optical communication device as claimed in any one of claims 12 to 20, wherein said output element is a beam diverger/collimator.

22. An optical communication device as claimed in any one of claims 12 to 20, wherein said input element provides a pilot beam and a signal beam whose composition form said input beam.

23. An optical communication device as claimed in claim 23, wherein said input element is an optical fiber.

1/2

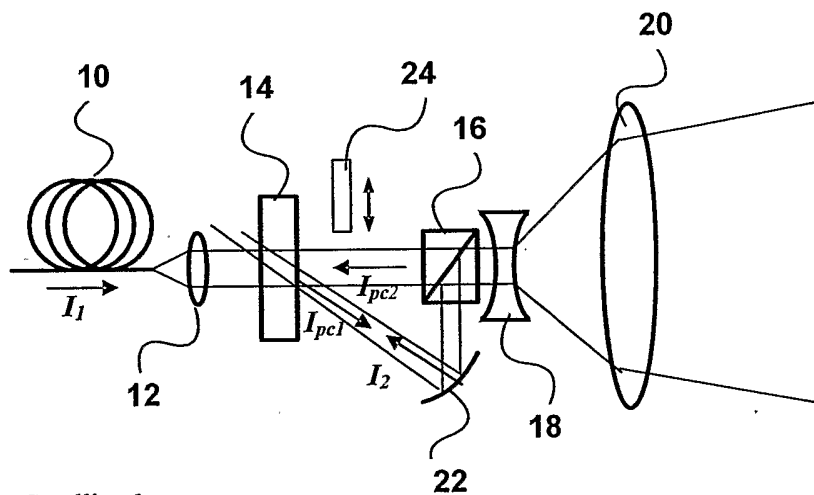

Satellite 1

FIG. 1a

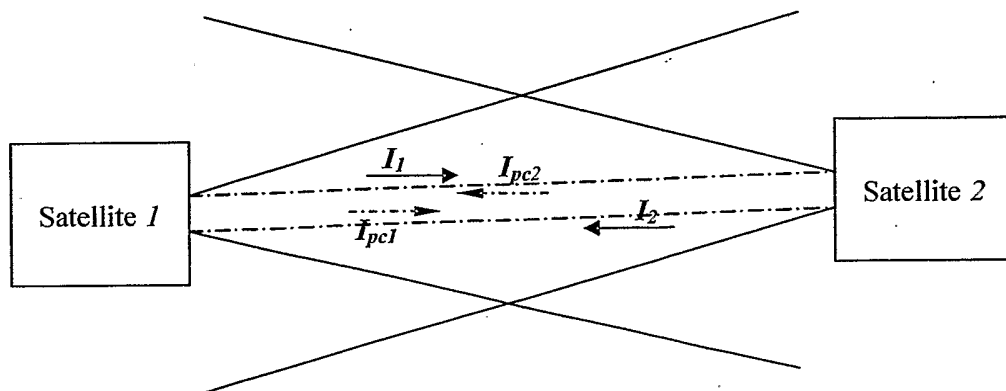
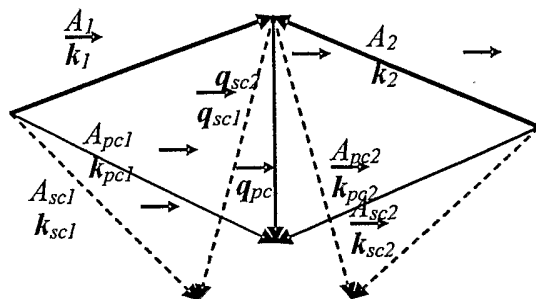

FIG. 1b

2/2



Nonlinear medium

FIG. 2

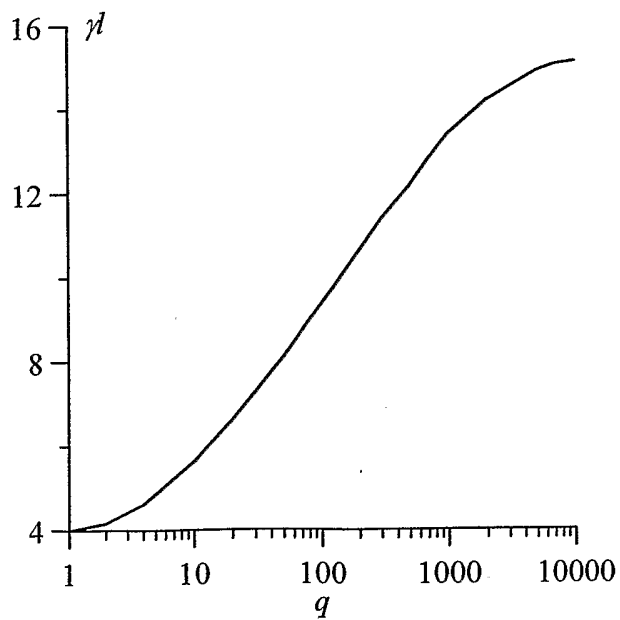

FIG 3

INTERNATIONAL SEARCH REPORT

International Application No

PCT/CA 03/00392

A. CLASSIFICATION OF SUBJECT MATTER

IPC 7 H04B10/105 G01S17/74 G02F1/35

According to International Patent Classification (IPC) or to both national classification and IPC

B. FIELDS SEARCHED

Minimum documentation searched (classification system followed by classification symbols)

IPC 7 H04B G01S G02F

Documentation searched other than minimum documentation to the extent that such documents are included in the fields searched

Electronic data base consulted during the international search (name of data base and, where practical, search terms used)

EPO-Internal, WPI Data, PAJ, INSPEC

C. DOCUMENTS CONSIDERED TO BE RELEVANT

Category *	Citation of document, with indication, where appropriate, of the relevant passages	Relevant to claim No.
X	US 5 317 442 A (SHARP EDWARD J ET AL) 31 May 1994 (1994-05-31)	1-5, 12-15, 18,22
Y	column 3, line 6 -column 4, line 13 column 5, line 35 -column 6, line 8 figures 1,2,5	6-10,16, 17,19, 21,23
Y	--- WO 01 78262 A (UNIV CALIFORNIA) 18 October 2001 (2001-10-18)	8-10,19, 21,23
A	page 16, line 1 - line 4 figure 6A --- -/--	11,20

 Further documents are listed in the continuation of box C. Patent family members are listed in annex.

* Special categories of cited documents :

- *A* document defining the general state of the art which is not considered to be of particular relevance
- *E* earlier document but published on or after the international filing date
- *L* document which may throw doubts on priority claim(s) or which is cited to establish the publication date of another citation or other special reason (as specified)
- *O* document referring to an oral disclosure, use, exhibition or other means
- *P* document published prior to the international filing date but later than the priority date claimed

- *T* later document published after the international filing date or priority date and not in conflict with the application but cited to understand the principle or theory underlying the invention
- *X* document of particular relevance; the claimed invention cannot be considered novel or cannot be considered to involve an inventive step when the document is taken alone
- *Y* document of particular relevance; the claimed invention cannot be considered to involve an inventive step when the document is combined with one or more other such documents, such combination being obvious to a person skilled in the art.
- *&* document member of the same patent family

Date of the actual completion of the international search

10 June 2003

Date of mailing of the international search report

17/06/2003

Name and mailing address of the ISA

European Patent Office, P.B. 5818 Patentlaan 2
NL - 2280 HV Rijswijk
Tel. (+31-70) 340-2040, Tx. 31 651 epo nl,
Fax: (+31-70) 340-3016

Authorized officer

Carrasco Comes, N

INTERNATIONAL SEARCH REPORT

International Application No

PCT/CA 03/00392

C.(Continuation) DOCUMENTS CONSIDERED TO BE RELEVANT

Category °	Citation of document, with indication, where appropriate, of the relevant passages	Relevant to claim No.
Y	US 5 557 431 A (PEPPER DAVID M) 17 September 1996 (1996-09-17) column 2, line 58 - line 63 column 4, line 65 - line 6 column 6, line 30 - line 41 -----	6,7,16, 17

INTERNATIONAL SEARCH REPORT

Information on patent family members

International Application No

PCT/CA 03/00392

Patent document cited in search report	Publication date	Patent family member(s)	Publication date
US 5317442	A	31-05-1994	NONE
WO 0178262	A	18-10-2001	AU 5138401 A 23-10-2001
			CA 2405274 A1 18-10-2001
			EP 1287629 A2 05-03-2003
			WO 0178262 A2 18-10-2001
			US 2001035995 A1 01-11-2001
US 5557431	A	17-09-1996	NONE