



INTERNATIONAL APPLICATION PUBLISHED UNDER THE PATENT COOPERATION TREATY (PCT)

<p>(51) International Patent Classification⁶ : G04G 1/00, 9/08</p>	A1	<p>(11) International Publication Number: WO 96/21888</p> <p>(43) International Publication Date: 18 July 1996 (18.07.96)</p>						
<p>(21) International Application Number: PCT/GB96/00069</p> <p>(22) International Filing Date: 15 January 1996 (15.01.96)</p> <p>(30) Priority Data:</p> <table border="0"> <tr> <td>9500668.0</td> <td>13 January 1995 (13.01.95)</td> <td>GB</td> </tr> <tr> <td>9502348.7</td> <td>7 February 1995 (07.02.95)</td> <td>GB</td> </tr> </table> <p>(71)(72) Applicant and Inventor: RADLEY-SMITH, Philip, John [GB/GB]; 6 Newcroft Cottages, Selsfield Road, Ardingly, West Sussex RH17 6TJ (GB).</p> <p>(74) Agent: PICKER, Madeline, Margaret; Brookes & Martin, High Holborn House, 52/54 High Holborn, London WC1V 6SE (GB).</p>		9500668.0	13 January 1995 (13.01.95)	GB	9502348.7	7 February 1995 (07.02.95)	GB	<p>(81) Designated States: AL, AM, AT, AU, AZ, BB, BG, BR, BY, CA, CH, CN, CZ, DE, DK, EE, ES, FI, GB, GE, HU, IS, JP, KE, KG, KP, KR, KZ, LK, LR, LS, LT, LU, LV, MD, MG, MK, MN, MW, MX, NO, NZ, PL, PT, RO, RU, SD, SE, SG, SI, SK, TJ, TM, TR, TT, UA, UG, US, UZ, VN, ARIPO patent (KE, LS, MW, SD, SZ, UG), Eurasian patent (AZ, BY, KG, KZ, RU, TJ, TM), European patent (AT, BE, CH, DE, DK, ES, FR, GB, GR, IE, IT, LU, MC, NL, PT, SE), OAPI patent (BF, BJ, CF, CG, CI, CM, GA, GN, ML, MR, NE, SN, TD, TG).</p> <p>Published</p> <p><i>With international search report. Before the expiration of the time limit for amending the claims and to be republished in the event of the receipt of amendments.</i></p>
9500668.0	13 January 1995 (13.01.95)	GB						
9502348.7	7 February 1995 (07.02.95)	GB						

(54) Title: BRACELET

(57) Abstract

A bracelet (1) comprises at least one electronic display unit (5). The or each display unit has a display (9) having a plurality of display elements (11) arranged in a sequence lying along the length of the bracelet and/or arranged in a sequence lying substantially around the perimeter of the display. The bracelet has control means (15) to control the display elements (11) so that the characters displayed by the display elements (11) appear to move along the sequence of display elements with time.

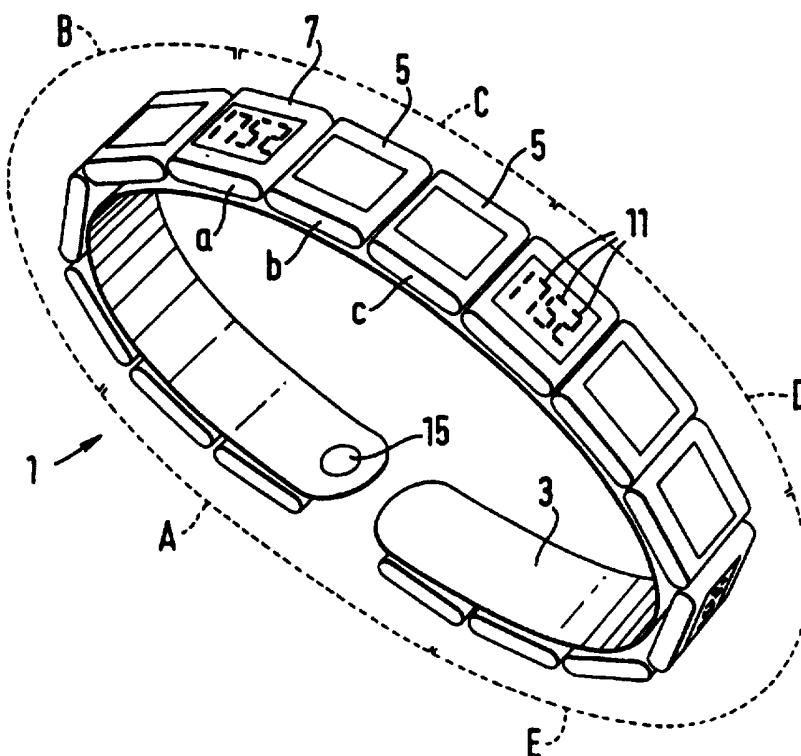

FOR THE PURPOSES OF INFORMATION ONLY

Codes used to identify States party to the PCT on the front pages of pamphlets publishing international applications under the PCT.

AT	Austria	GB	United Kingdom	MR	Mauritania
AU	Australia	GE	Georgia	MW	Malawi
BB	Barbados	GN	Guinea	NE	Niger
BE	Belgium	GR	Greece	NL	Netherlands
BF	Burkina Faso	HU	Hungary	NO	Norway
BG	Bulgaria	IE	Ireland	NZ	New Zealand
BJ	Benin	IT	Italy	PL	Poland
BR	Brazil	JP	Japan	PT	Portugal
BY	Belarus	KE	Kenya	RO	Romania
CA	Canada	KG	Kyrgystan	RU	Russian Federation
CF	Central African Republic	KP	Democratic People's Republic of Korea	SD	Sudan
CG	Congo	KR	Republic of Korea	SE	Sweden
CH	Switzerland	KZ	Kazakhstan	SI	Slovenia
CI	Côte d'Ivoire	LI	Liechtenstein	SK	Slovakia
CM	Cameroon	LK	Sri Lanka	SN	Senegal
CN	China	LU	Luxembourg	TD	Chad
CS	Czechoslovakia	LV	Latvia	TG	Togo
CZ	Czech Republic	MC	Monaco	TJ	Tajikistan
DE	Germany	MD	Republic of Moldova	TT	Trinidad and Tobago
DK	Denmark	MG	Madagascar	UA	Ukraine
ES	Spain	ML	Mali	US	United States of America
FI	Finland	MN	Mongolia	UZ	Uzbekistan
FR	France			VN	Viet Nam
GA	Gabon				

BRACELET

The present invention relates to a bracelet.

5 The term, "bracelet", when used in this specification, is not limited to a wrist bracelet but is intended to include bracelets such as ring or belt bracelets which may be worn on other parts of the body, such as the ankle, a finger or even around the waist. Furthermore, such bracelets need not be solely for human use but could be worn by animals, e.g. as collars, or, if desired, attached to inanimate objects.

10

A known bracelet which displays information is a digital watch, having a watch face with a liquid crystal display. Typically, the watch face has at least four conventional seven-segment numerical display elements so that the time can be displayed digitally using the standard 24 hour clock notation.

15

The watch will usually have additional functions such as an alarm, a stop-watch, etc. and so a solid state chip/integrated circuit is included to implement these functions together with a quartz crystal to keep time and a battery for powering the watch.

20 The present invention provides a bracelet having an electronic display unit including a display region comprising a plurality of display elements, each display element capable of displaying a character of one or more characters so that the display elements together can display said characters, in the display region; the display elements being arranged in a sequence lying along the length of the bracelet and/or
25 in a sequence lying substantially around at least part of the perimeter of the display region; wherein control means is provided to control the display elements so that the characters displayed by the display elements in the display region appear to move along the sequence of display elements with time.

30 In one embodiment, the bracelet has a single display unit extending along a portion of the length of the bracelet.

Preferably, the single unit has a plurality of display elements each comprising a lattice of liquid crystal or LED segments. The liquid crystal or LED segments may be selectively energised to display one of a plurality of different characters. Preferably, the liquid crystal or LED segments are arranged, and may be selectively energised, to display numerical and/or alphabetical characters.

However, it will be appreciated that abstract characters and shapes could be formed by the display elements to give the appearance of a moving pattern.

The control means may be a solid state chip/integrated circuit which can control the display elements to display information in the form of characters. The solid state chip may control the display elements so that the characters displayed appear to move along the sequence of display elements in the display region, element by element, with time.

The display region can be divided into a plurality of sub-regions each comprising a plurality of display elements forming a portion of the sequence of display elements. It is then possible for the display elements to display information simultaneously within each sub-region and the control means may control the display elements such that the information displayed in each sub-region appears to move, preferably element by element, from a first end of said respective portion of said sequence of display elements to a second end of said respective portion of said sequence of display elements with time.

In another embodiment, the bracelet comprises a plurality of electronic display units each having a predetermined number of display elements. The display elements of the display units together form a display region, each display element being capable of displaying a character of one or more characters so that the display elements together can display information, in the form of said characters, in the display region.

The display units are arranged so that collectively their display elements form a

sequence lying along the length of the bracelet. The display units are preferably arranged in groups of at least three adjacent units, each group forming a sub-region of said display region so that the display elements can display information simultaneously within each sub-region. Control means is provided to control the display elements to display characters such that the characters are displayed in each group of display units, firstly, in the first unit of the group of display units, secondly in the second unit of the group of display units and thirdly in a third unit of the group of display units so that the characters appear to move, within the sub-region of said display region, with time.

10

Further preferred and advantageous features of the present invention will be apparent from the following description and accompanying claims.

15

Embodiments of the present invention will now be described by way of example, with reference to the accompanying drawings, in which:

Figure 1 is a side view of a bracelet forming a first embodiment of the present invention;

20

Figure 2 is a perspective view of the bracelet of Figure 1;

Figure 3 is a perspective view of a bracelet forming a second embodiment of the present invention;

25

Figure 4a is an enlarged plan view of a part of the liquid crystal display of the bracelet of Figure 3, and Figure 4b is a plan view of a corresponding part of an alternative liquid crystal display for the bracelet of Figure 3;

30

Figure 5 is a side view of a bracelet forming a third embodiment of the present invention;

Figure 6 is a perspective view of the bracelet of Figure 5;

Figures 7 to 10 show plan views of various liquid crystal display elements which can be used in a bracelet according to the present invention;

5

Figure 11 is a perspective view of a bracelet forming a third embodiment of the present invention;

10

Figures 12a, b and c are side views of the bracelet of Figure 11 lying flat, in an intermediate position, before being fastened and in a final position fastened for use, respectively;

15

Figure 13 is a perspective view of a bracelet forming a fourth embodiment of the present invention;

Figure 14 is a perspective view of a bracelet forming a fifth embodiment of the present invention;

20

Figure 15 is a perspective view of a bracelet forming a sixth embodiment of the present invention;

Figure 16 is a perspective view of a bracelet forming a seventh embodiment of the present invention;

25

Figures 17a, b and c are plan views of alternative arrangements of display elements for use with the bracelet of Figure 16;

Figures 18a, b and c show plan views of a "dot matrix" liquid crystal display element displaying different shapes and figures, and

30

Figures 19a, b and c are perspective views of a bracelet forming an eighth embodiment of the present invention, each view showing the display at successive moments in time.

5 Figures 1 and 2 show a bracelet 1 forming a first embodiment of the present invention. The bracelet 1 comprises a strap 3 carrying a plurality of digital electronic display units 5. It will be understood, however, that the display units could be made integral with the strap.

10 The display units 5 can conveniently be of any conventional type used for watches, calculators, or the like. In this way, the bracelet can be manufactured cheaply by using "off-the-shelf" parts. In the illustrated embodiment, conventional watch units are used. Such units are individually housed in cases 7 and each have a compartment
15 for a battery to provide power to the unit, a quartz crystal for time keeping and control chip/integrated circuit to control the display unit. It will be appreciated that all units could be powered by a single battery and a single quartz crystal and/or control chip could be employed for all the units. Each unit 5 has a liquid crystal display (LCD) 9 comprising a sequence of four display elements 11, the sequence
20 arranged to lie, in a line, along the length of the bracelet, which are controlled by the control chip.

In this embodiment, the liquid crystal display of each unit has only four display elements, but it will be appreciated that the LCD could include more than four display
25 elements.

The display elements of the display units together form a display region of the bracelet.

Each display element 11 has a conventional arrangement of seven liquid crystal
30 segments which can be selectively energised to display any single numerical character

from 0 to 9. Thus, the units can be used to display numerical information up to four figures, such as the time in 24 hour clock notation.

5 The units 5 are arranged in groups (labelled A, B, C, D, E) of 3 units, each group forming a sub-region of the display region. The units 5 can, if required, each be individually set to the correct time. However, in the illustrated embodiment, the bracelet 1 is provided with an integrated circuit 15 which controls all units so that each unit can be programmed with the same time simultaneously. It will be appreciated that each group of units 5 could be programmed independently of the
10 other groups, so that different times could be displayed by each group, for example, to show the time in different time zones.

Each sub-region of the display region displays characters simultaneously with the other sub-regions. Thus, characters are displayed at regular intervals along the
15 bracelet and so viewing is possible from a number of different angles.

Each group of units comprises three display units a, b and c. Each of the three display units have an integrated circuit/chip or other control circuit which switches the LCD display 9 on and off intermittently and, in particular, the LCD display 9 is
20 switched on for a period of one second every three seconds in time.

Integrated circuit 15 synchronises the three units 5 in the groups so that only one unit in a group is displaying at any one time. The units are synchronised so that the left-hand unit of the three, a, displays information, the time in numerical characters, say,
25 for a first second, the middle unit, b, displays the time for the next second and the right-hand unit, c, displays the time in the following (i.e. third) second. This cycle of displaying the time successively on each unit, is then repeated so that in a fourth second the left-hand unit, a, displays the time again and so on.

30 It will be appreciated that if the individual display units were independently

programmed with the time, they could also be independently programmed to switch their LCD displays on and off to synchronise the display of the time as set out above so that synchronising integrated circuit 15 would not be necessary.

- 5 It will be appreciated that the direction of movement of the information could be reversed to travel from right to left.

The result is that, in use, the switching on and off of the display units gives the appearance of a continuous movement of the information (i.e. the time) within the
10 sub-region along the length of the bracelet.

It will be appreciated that more than three units can be used in each group so that the information displayed will be spaced further apart. It will also be appreciated that the speed and duration of switching the LCD of each unit on and off can be varied to
15 change the look and manner of the movement of information along the bracelet.

However, the use of three units in each group has the advantage that the time is displayed frequently on the face of any one unit which is being viewed so that the need for the wearer to turn his wrist to see the time displayed is eliminated.

20

Figure 3 shows a second embodiment of the present invention. Features corresponding to those described in the first embodiment are given like reference numerals. In this embodiment the bracelet 1 has a single display unit 5 incorporating an LCD 9 extending along substantially the full length of the bracelet. The display
25 unit 5 is, in this embodiment, integral with the strap 3.

The LCD 9 provides a display region and comprises a large number of adjacent display elements 11 for displaying information in a sequence along the length of the bracelet. As shown in Figure 4, each element is an alphanumeric display element
30 comprising thirteen liquid crystal segments arranged in a lattice so that the segments

can be selectively energised to display any numeral from 0 to 9 and any letter from A to Z. Alternatively, each element could comprise a sixteen segment alphanumeric display element as shown in Figure 4b which can similarly display any numeral from 0 to 9 and any letter form A to Z. Thus, the bracelet 1 can be used to display information other than simply the time. The information could be stored as messages and such messages could be pre-programmed into memory and read out and displayed by a controlling integrated circuit/chip 15.

It is envisaged that the bracelet could also or alternatively be programmed by the user by downloading information from an electronic personal organiser or personal computer into the memory of the bracelet. Methods of doing this are known in the art and will not be described herein.

The bracelet might also include a receiver for receiving data, transmitted in the form of electromagnetic radiation such as radio waves, which could be programmed into the memory and subsequently displayed by the bracelet. Thus, the bracelet could be used as a pager or to display the latest travel information or sports results.

The control chip/integrated circuit 15 of the bracelet 1 according to this second embodiment, can be used to energise the display elements 11 of the LCD 9 to display a message, for instance, "THE TIME IS 1752". The chip/integrated circuit 15 can also control the LCD to move the message by changing the energization of individual display elements with time. In the same way as with the first embodiment, control of the switching of the display elements 11 can give the appearance of a moving message. However, in the second embodiment, it is preferred to move the message on, one element at a time, so that the movement is more fluent. Additionally, the message can be moved along virtually the whole length of LCD, which effectively extends along whole length of the bracelet 1, instead of being moved within a sub-region of the LCD.

30

It will be appreciated that a message which is longer than the length of the LCD 9 can be displayed by virtue of the movement of the information across the display, although there will always be a part of the message (at the beginning or the end) which is not visible on the LCD.

5

It will further be appreciated that the bracelet of the second embodiment of the invention will have a quartz crystal for time-keeping, and may include the usual alarm functions of a watch. Furthermore, an alarm function can be used to trigger a message for the wearer, such as a reminder of an appointment, etc.

10

This embodiment can be utilised for many purposes. For instance, a bracelet could be used in hospitals to store details of a patient's identity, their relevant medicine, etc. The bracelet could also be used by children to give personal information. Alternatively, the bracelet could be simply used as an item of jewellery.

15

Figures 5 and 6 show a third embodiment of the present invention. In this embodiment, which is similar to the second embodiment, the strap of the bracelet 3 is continuous by virtue of the use of a conventional catch 17 and hinge 19 arrangement. This enables the liquid crystal display 9 to extend around the total length of the bracelet so that a moving message will appear to circulate (or cycle) continuously around the bracelet.

20

Further features, and the operation, of the third embodiment are the same as that of the second embodiment and so the reader is referred to the description of the second embodiment.

25

Figures 11 and 12 shows a fourth embodiment of the present invention. In this embodiment the bracelet 1 has a flexible fabric "wrap-around" strap 3 which carries a display unit 5 incorporating an LCD 9 extending along its length. The LCD 9 forms a display region and has a sequence of adjacent alphanumeric display elements

30

11 for displaying characters, and is controlled by a control chip (not shown).

The strap 3 has hook 31 and loop 33 Velcro® fastening pads on opposite sides of respective ends to enable the strap to be adjustably fastened around the wrist of a user.

5

Characters can be displayed and moved along the length of the bracelet under the control of a control chip in the same manner as described in respect of previous embodiments.

10 Since the strap of the bracelet of this embodiment is a "wrap-around" strap, a portion 27 of one end of the strap will overlap a portion 29 of the other end of the strap. As a consequence of the overlap, some of the display elements 11 at the right hand end of the bracelet may not be visible, the number depending upon the size of wrist of the user. In Figure 12b four display elements (WXYZ) are hidden.

15

In order to avoid part of the message being obscured by the overlap of the strap, and in order to maintain a continuous movement of the message around the bracelet, the hidden display elements are not utilised. Thus, if the control chip moves a displayed message from left to right, when the right-most letter or numeral of the message reaches the last display element (V) before the hidden elements, it will skip the hidden elements (WXYZ) and restart the message at the first display element (A). In this way continuity of movement of the message is maintained.

20

In order to achieve this, the user must program into the control chip the identity (location) of those display elements which are overlapped when the bracelet is fastened on his wrist. Alternatively, the bracelet could be fitted with one or more sensors to detect which display elements are overlapped and to automatically program the control chip accordingly.

25

30 Figure 13 shows a fourth embodiment of the present invention which is a variation

of the second embodiment. In this arrangement the bracelet 1 is a watch bracelet and has a conventional analog watch face 35 and the LCD 9 runs along the length of the bracelet across the watch face 35.

5 Figure 14 shows a fifth embodiment of the present invention. This embodiment is similar to that shown in Figure 13 except that the LCD 9 does not run across the analog display face 35. Accordingly, in this embodiment, a circulating message will be controlled to give the appearance of the message "jumping" from one side of the analog watch face 35 to the other.

10

Figure 15 shows a sixth embodiment of the present invention. In this embodiment, the bracelet 1 is a watch having a conventional strap 3. The face 35 of the watch has an analog display 37 at its centre which is surrounded by an LCD 9 extending in a closed loop around the perimeter of the face 35.

15

The LCD 9 comprises a sequence of alphanumeric display elements 11 which are arranged in a sequence lying around the perimeter of the watch face, so that characters can be displayed around the central analog display 37.

20 Additionally, the characters displayed on the LCD can be controlled by a control chip (not shown) to give the appearance of movement around the perimeter of the watch face in the same way as a message appears to move along the length of the bracelet in the previously described embodiments. In this way, a message can be displayed which has more characters than the number of display elements on the watch face.

25

Figure 16 shows a seventh embodiment of the present invention. This embodiment utilises a more complex LCD arrangement by combining the features of the fifth embodiment with the features of the sixth embodiment. Thus, the bracelet 1 has a circular face 35 and an LCD 9 comprising a first sequence 9a of alphanumeric display elements 11, extending along the length of the bracelet and a second sequence 9b of

30

alphanumeric display elements extending in a closed loop around the perimeter of the face. At a first interface 51 between the first sequence 9a and the second sequence 9b there is an overlap of four display elements (4,5,28,29) as shown in Figure 17a. Similarly at a second interface there is an overlap of a further four display elements
5 (16,17,40,41).

A control chip can accordingly "move" characters, which typically form a message, in a path along the length of the bracelet, then smoothly onto the face 35 utilising the appropriate display elements (4 & 5) at the interface, around the perimeter of the face
10 and then smoothly off the face and along the length of the bracelet again, as shown by the directional arrows illustrated in Figures 16 and 17. The direction of movement can be from left to right or right to left along the bracelet and can be clockwise or anticlockwise around the perimeter of the face of the bracelet.

15 It will be appreciated that just a part of the sequence of display elements around the perimeter of the watch face could be used to display the message. Thus, for instance, the message could be moved along the bracelet from left to right around the top or bottom semicircle of the watch face.

20 In an alternative arrangement of display elements, the second sequence 9b of the display elements has the additional sequence of display elements 9c shown in Figure 17c which underlie display elements numbered 5 to 16 in Figure 17b. These elements are utilised when the message has completed a circle around the perimeter of the face. This allows a longer message to be displayed because two parts of a message do not
25 "share" the same display elements, as would otherwise be the case, which would result in a conflict in what is displayed on those elements.

It will be appreciated that the watch face need not be circular but could be rectangular or oval. Furthermore, the LCD need not extend around the total perimeter of the face
30 but could form an open loop so that the beginning and end of a message is clearly

visible.

It will be appreciated that various modifications can be made to the described embodiments. For instance, the bracelet could employ suitable displays other than the described segmental LCD display elements, for example segmental LED display elements could be used. Furthermore, the LCD display unit or units can have display elements other than the numeric seven-segment or alphanumeric thirteen or sixteen-segment arrangements. An example is a "dot matrix" type display element having twenty five liquid crystal cells arranged in a rectangular matrix (see figure 18a which shows all the cells energised). The cells can be selectively energised to display many different shapes and figures as shown in figures 18b and c, as well as letters from the Greek or Russian alphabets, Chinese characters, etc. In the claims the term "segment" is intended to encompass the "cells" of such a dot-matrix display element.

The display elements could also display shapes or figures such as animals or characters which might move. Examples of these are shown in Figures 7 to 10.

In particular, Figure 7 shows display elements with liquid crystal segments arranged to form the shape of a dinosaur. Figure 7a shows a first position of the dinosaur and Figure 7b shows a second position of the dinosaur. It will be understood that the energizing of successive elements alternately in the first and second positions will give the impression of movement of the dinosaur. Figure 7c shows the crystal segments common to the two positions of the dinosaur in Figure 7a and Figure 7b. Figure 7d shows in dotted lines the additional segments required to enable the display element to show the dinosaur in both the first and second positions, and Figure 7e shows all the crystal segments required to form the shape of the dinosaur in both positions.

Figures 8, 9 and 10 show how moving figures (in this case an ant-like creature) can be formed by using the conventional thirteen-segment alphanumeric crystal arrangement together with an additional LCD lattice arrangement of crystal segments.

The additional lattice can underlie or overlie the thirteen-segment alphanumeric LCD lattice. The number and arrangement of the segments in the additional lattice (shown in Figure 8c) can be varied, and its position relative to the alphanumeric display (shown in Figure 8b) can also be varied to alter the shape of the creature (e.g. to give it short legs rather than long legs).

By using the conventional alphanumeric lattice, a message can be moved along the bracelet and, if the creature is displayed by a display element immediately after the left most letter or numeral of the message is displayed by that display element, the creature can appear to be chasing the message as it moves along the LCD of the bracelet. Similarly, if the creature is displayed immediately before the right most letter or numeral of the message, the message will appear to be chasing the creature.

Figure 19 shows an eighth embodiment of the present invention having a plurality of display units 5 similar to those of the first embodiment. Each display unit 5 has two overlapping lattices of liquid crystal segments. One lattice comprises four, seven-segment numerical display elements as in the first embodiment and the other lattice comprises a dinosaur lattice of two possible configurations, as shown in Figure 7e. The display units 5 display the time, the dinosaur in a first configuration and the dinosaur in the other configuration alternately to give the impression of movement. Thus, Figures 19a, b and c show the characters displayed on the bracelet at successive moments in time.

It would be possible to incorporate different colour lighting units with each display unit 5 so that one colour is associated with each type of character displayed. For example, a blue light could be lit when the time is displayed, a red light when the dinosaur is displayed in the first configuration and an orange light with the dinosaur in the other configuration. Thus light patterns could be produced which move along the bracelet with time.

30

Various modifications may be made to the described embodiments and it is intended to include all such variations and modifications as fall within the scope of the accompanying claims.

CLAIMS

1. A bracelet having an electronic display unit including a display region comprising a plurality of display elements, each display element capable of displaying a character of one or more characters so that the display elements together can display characters, in the display region; the display elements being arranged in a sequence lying along the length of the bracelet and/or in a sequence lying substantially around at least part of the perimeter of the display region; wherein control means is provided to control the display elements so that the characters displayed by the display elements in the display region appear to move along the sequence of display elements with time.
2. A bracelet as claimed in claim 1, wherein the control means controls the display elements so that the characters appear to move along the sequence of display elements in the display region, element by element, with time.
3. A bracelet as claimed in claim 1 or claim 2, wherein the display elements each comprise a plurality of independently controllable liquid crystal or LED segments which can be selectively energised to display one of a plurality of different characters.
4. A bracelet as claimed in claim 3, wherein the liquid crystal or LED segments are arranged to display numerical and/or alphabetical characters.
5. A bracelet as claimed in claim 4, wherein the display elements can display a message, in the form of numerical and/or alphabetical characters, of a length greater than the number of display elements in the display region.
6. A bracelet as claimed in any preceding claim, wherein the control means comprises an integrated circuit.

7. A bracelet as claimed in any preceding claim, further comprising memory means to store a message for display by the display elements.

5 8. A bracelet as claimed in claim 1, wherein the display region is divided into a plurality of sub-regions each comprising a plurality of display elements forming a portion of said sequence of display elements, the display elements being capable of displaying characters simultaneously within each sub-region; whereby the control means controls the display elements such that the characters displayed in each sub-region appears to move, element by element, from a first end of said respective
10 portion of said sequence of display elements to a second end of said respective portion of said sequence of display elements.

9. A bracelet as claimed in claim 8, wherein, for each sub-region, when the characters reach the second end of the portion of the sequence of display elements,
15 the characters are immediately thereafter displayed again at the first end of the portion of the sequence of display elements.

10. A bracelet as claimed in claim 1, in which the display elements are arranged in a sequence lying along the length of the bracelet, the bracelet comprising a plurality
20 of electronic display units each having a predetermined number of display elements, the display elements of the display units together forming said display region, the display units being arranged in groups of at least three adjacent units each group forming a sub-region of said display region so that the display elements can display characters simultaneously within each sub-region; wherein the control means controls
25 the display elements such that characters are displayed in each group of display units, firstly in a first unit of the group of display units, secondly in a second unit of the group of display units and thirdly in a third unit of the group of display units, so that the characters appear to move, within the sub-region of said display region, with time.

1/12

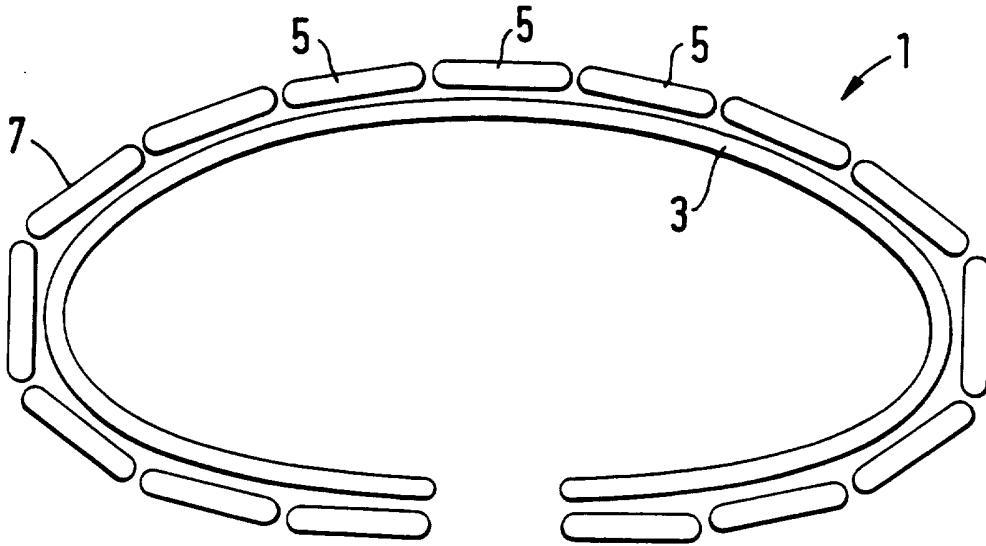

Fig. 1

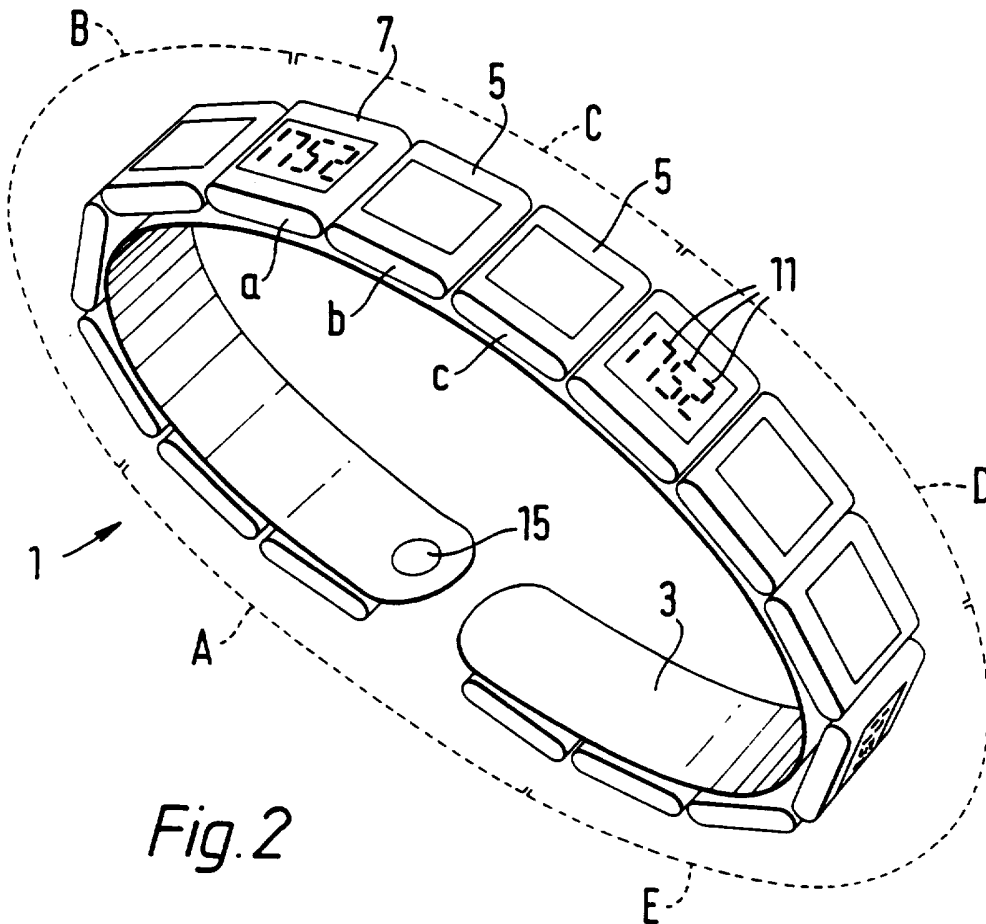

Fig. 2

2/12

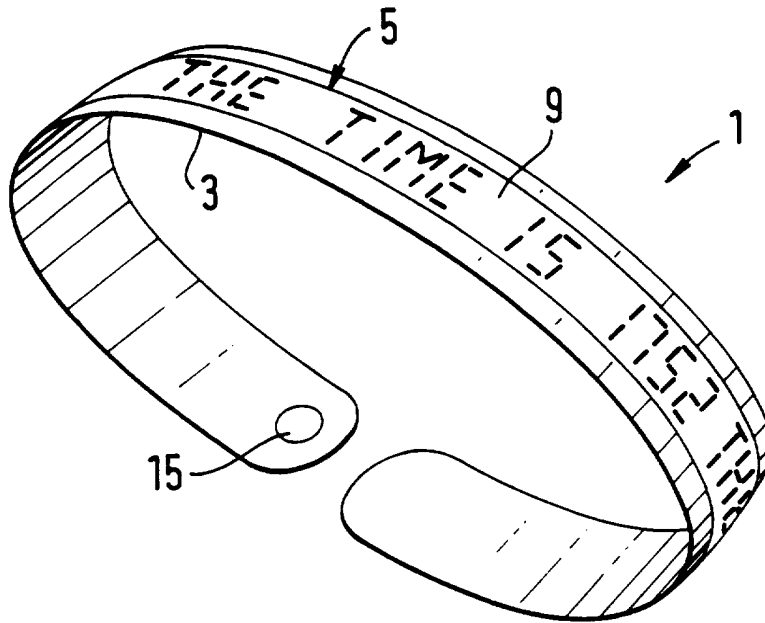

Fig. 3

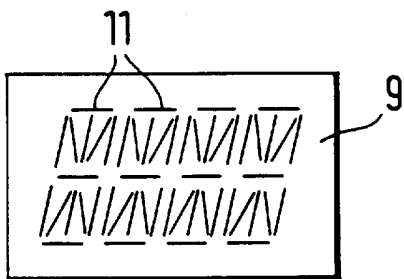

Fig. 4a

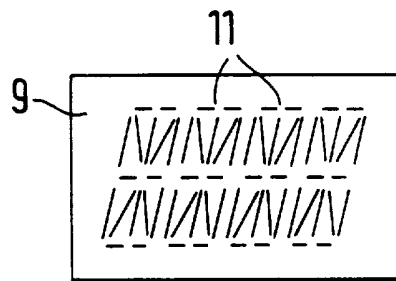

Fig. 4b

3/12

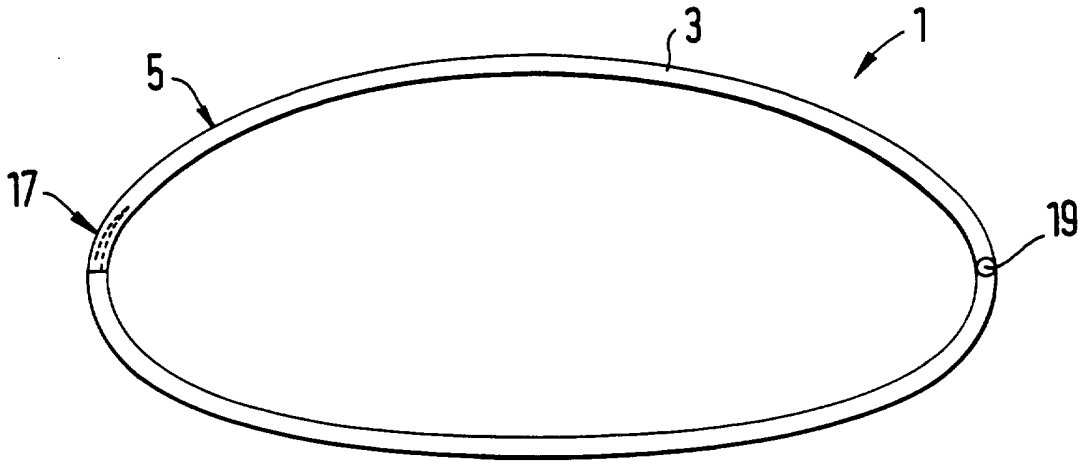

Fig. 5

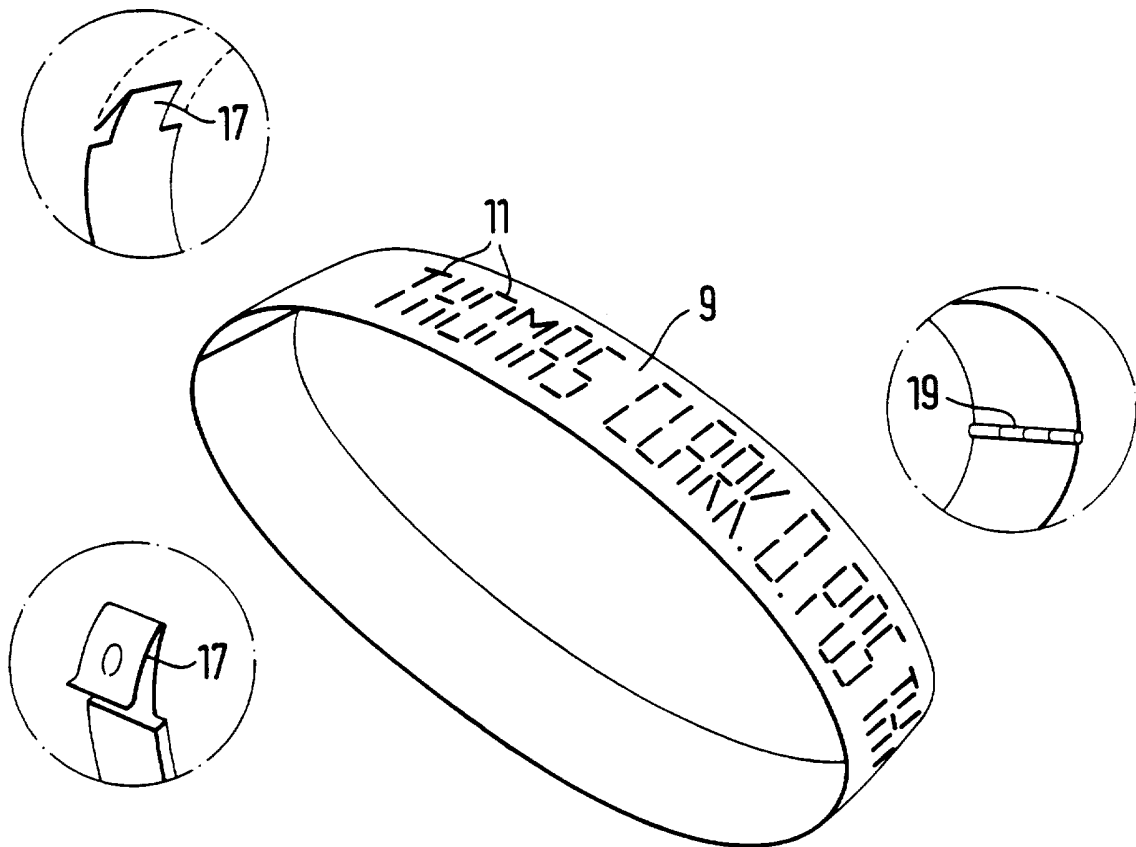

Fig. 6

4/12



Fig. 7a

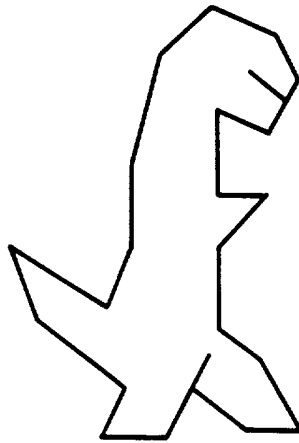

Fig. 7b



Fig. 7c

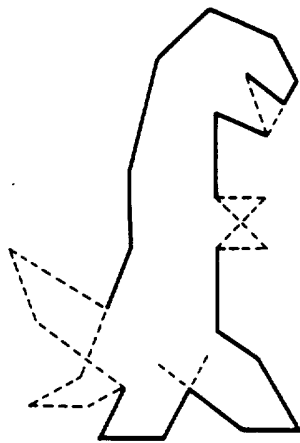

Fig. 7d



Fig. 7e

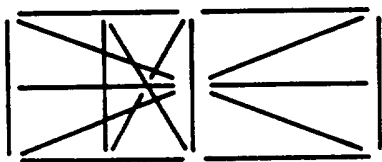

Fig. 8a

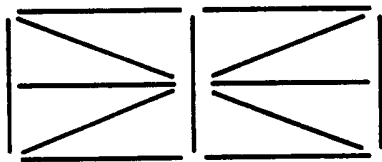

Fig. 8b



Fig. 8c

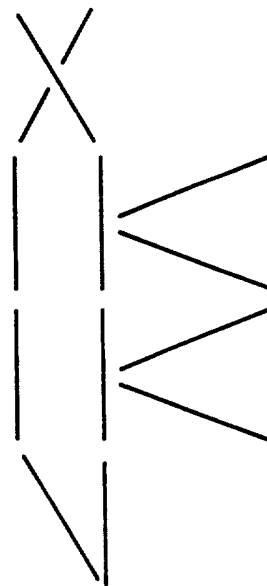

Fig. 8d

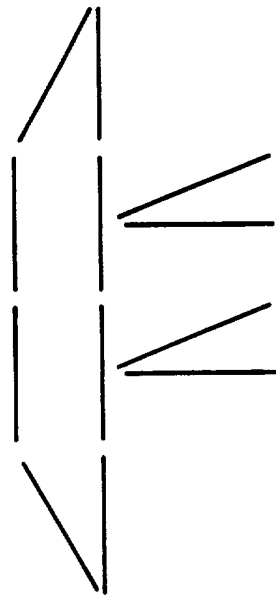

Fig. 8e

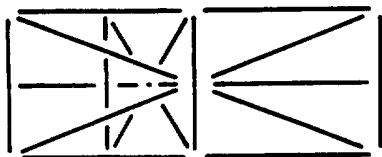

Fig. 9a

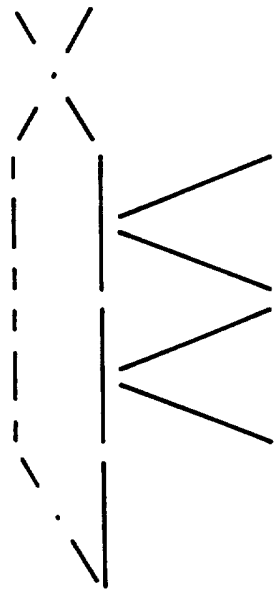

Fig. 9b

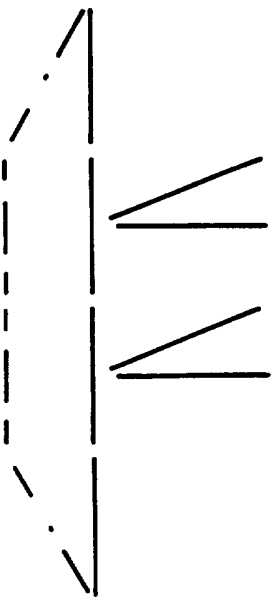

Fig. 9c

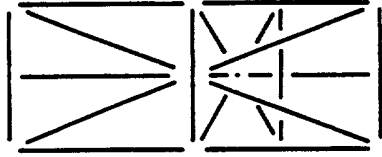

Fig. 10a

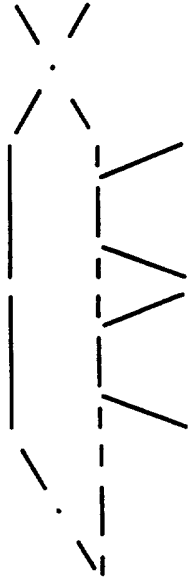

Fig. 10b

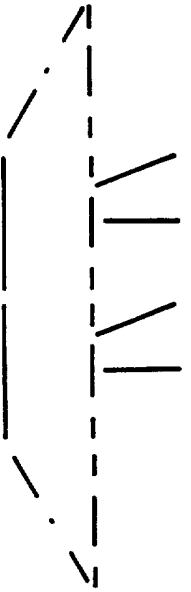

Fig. 10c

7/12

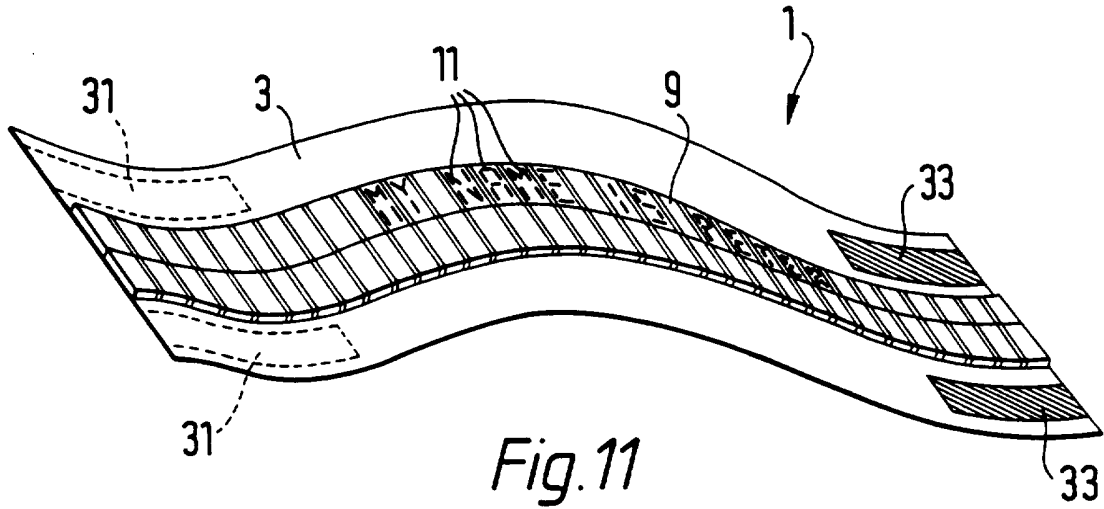

Fig. 11

Fig. 12a

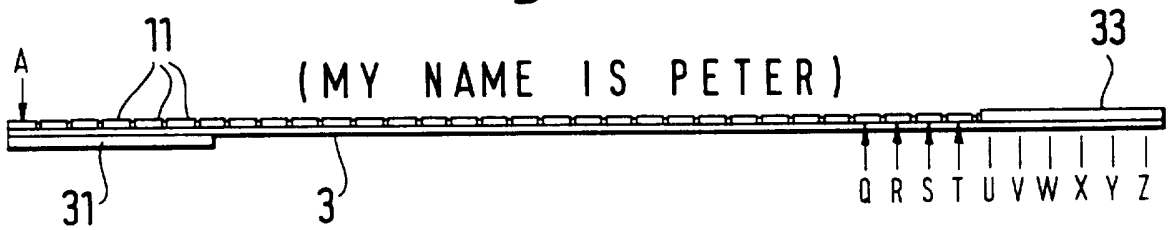

Fig. 12b

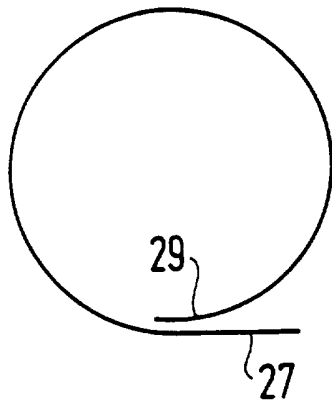
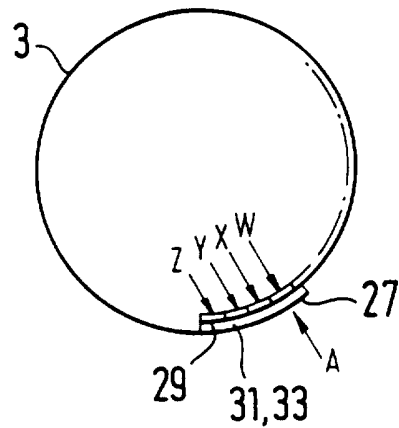

Fig. 12c



8/12

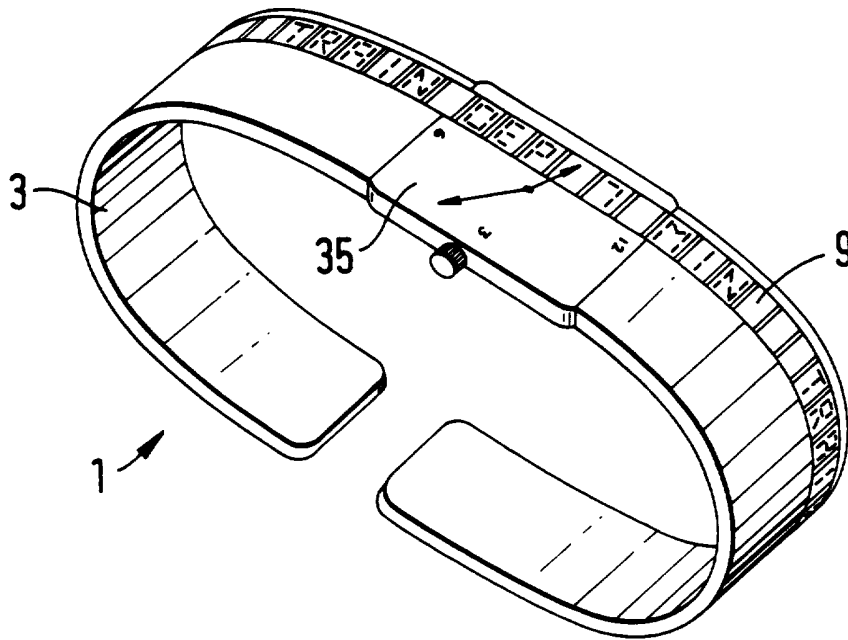

Fig.13

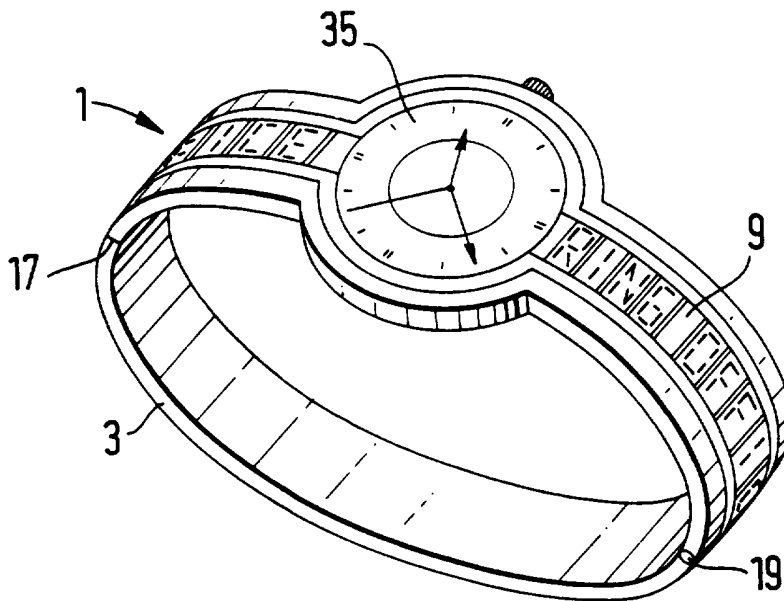

Fig.14

9/12

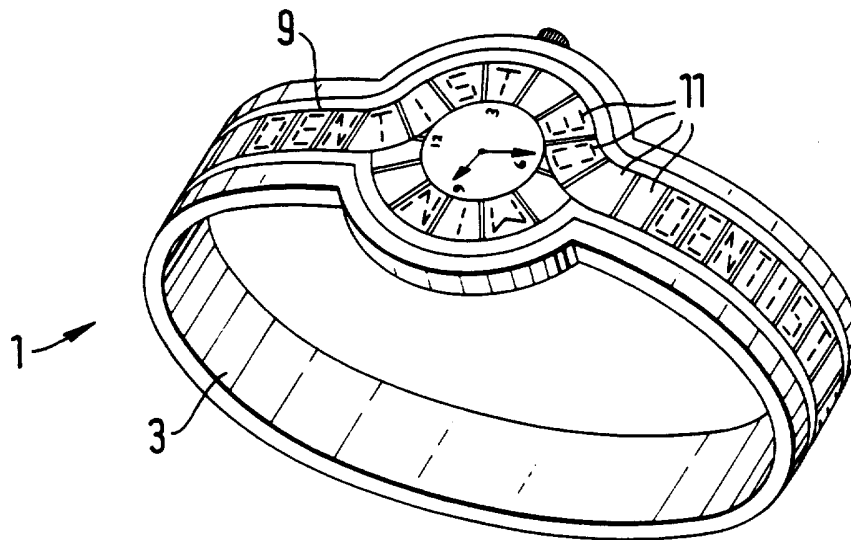
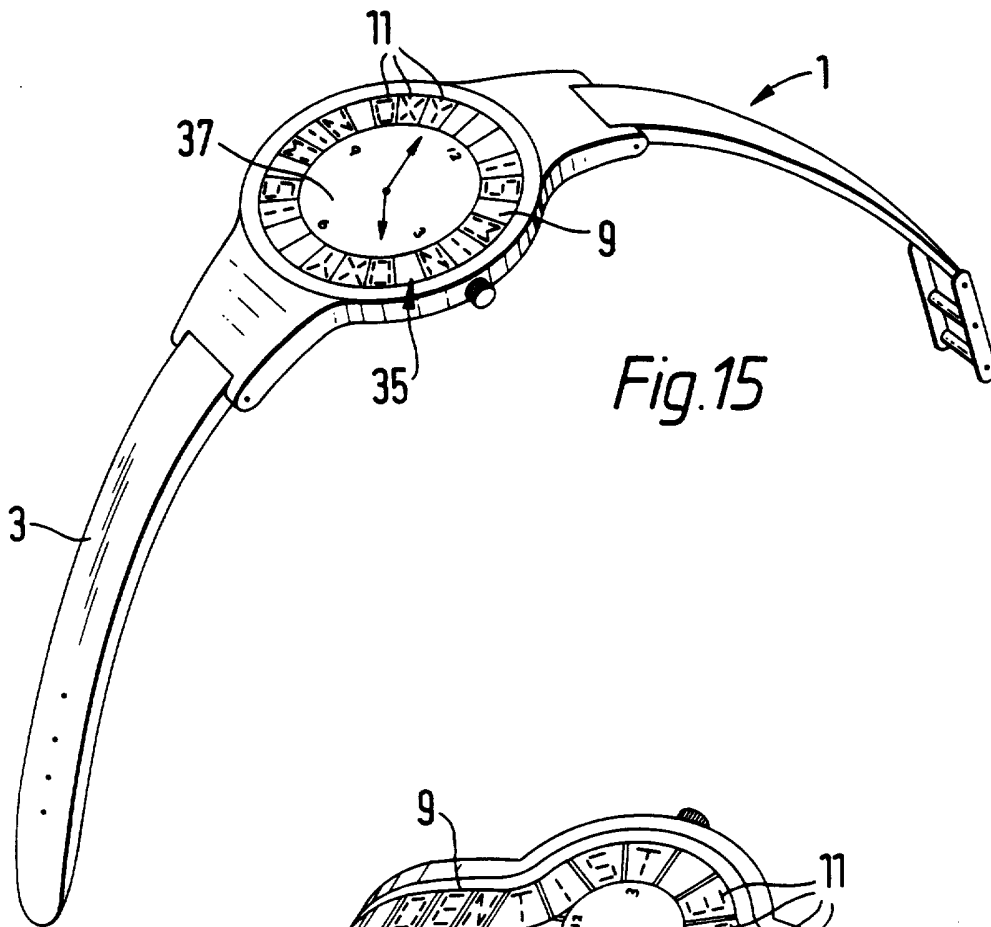
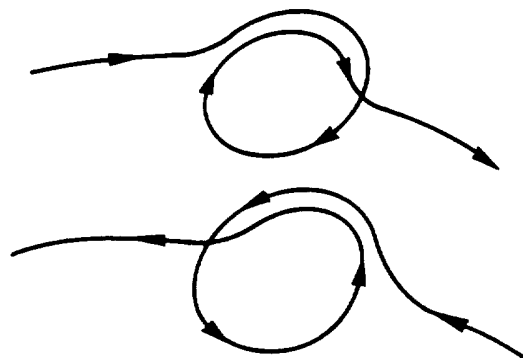

Fig. 16



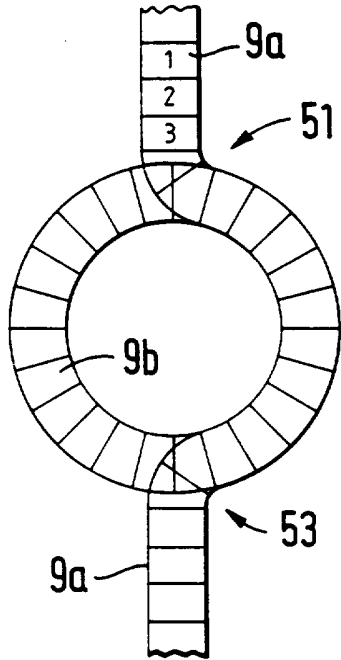

Fig. 17a

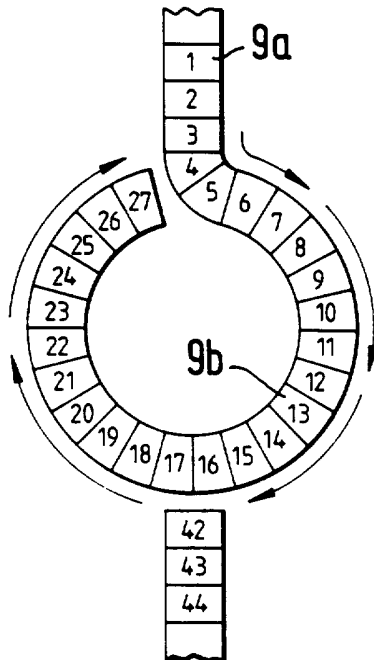

Fig. 17b

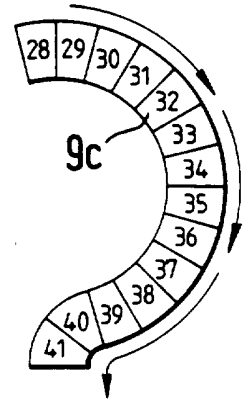

Fig. 17c

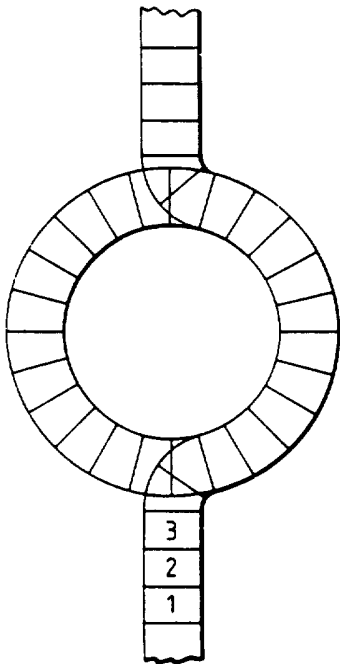

Fig. 17d

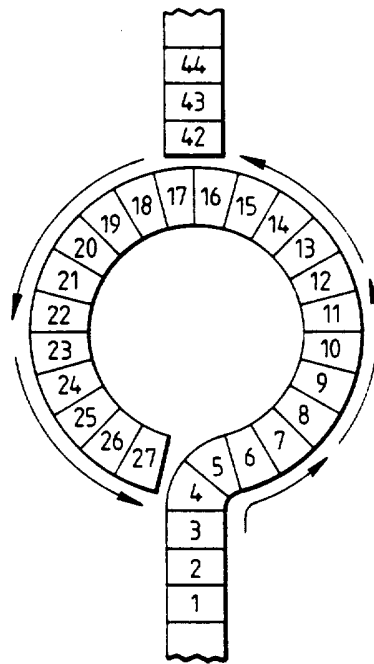

Fig. 17e

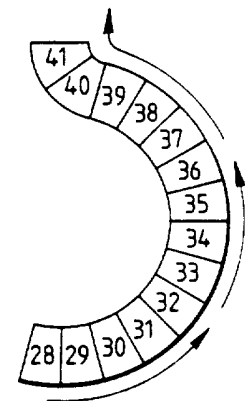

Fig. 17f

11/12

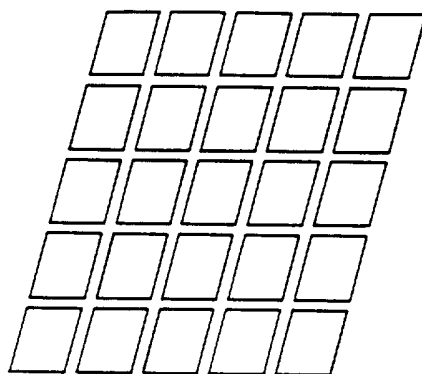

Fig.18a

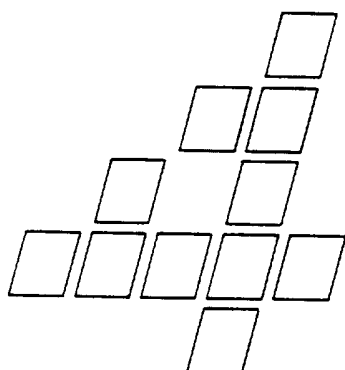

Fig.18b

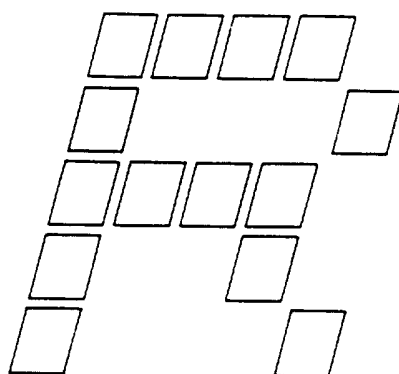

Fig.18c

Fig.19a

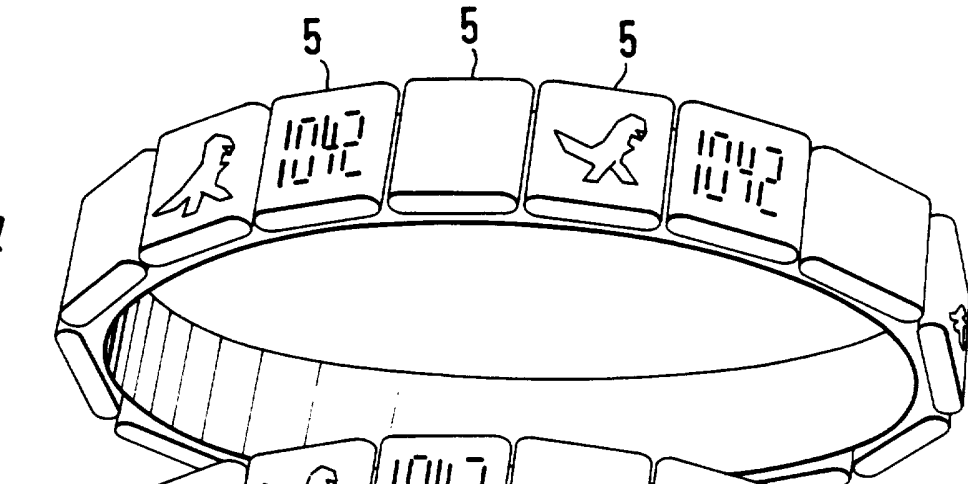

Fig.19b

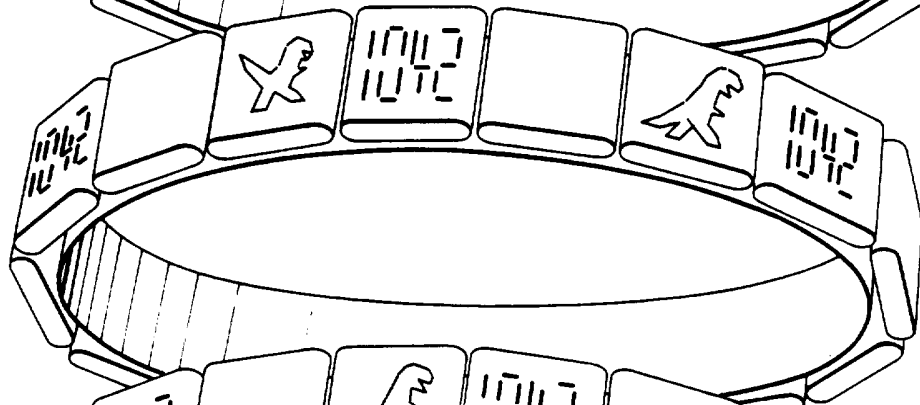
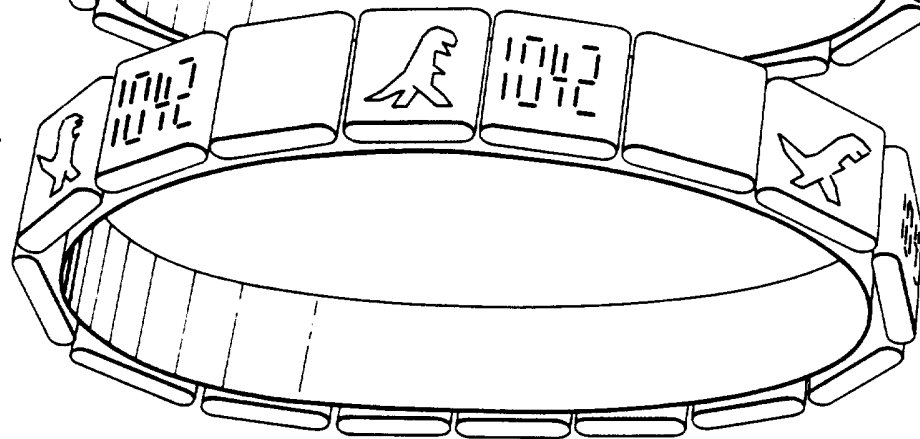

Fig.19c



INTERNATIONAL SEARCH REPORT

International Application No
PCT/GB 96/00069

A. CLASSIFICATION OF SUBJECT MATTER
IPC 6 G04G1/00 G04G9/08

According to International Patent Classification (IPC) or to both national classification and IPC

B. FIELDS SEARCHED

Minimum documentation searched (classification system followed by classification symbols)

IPC 6 G04G A44C

Documentation searched other than minimum documentation to the extent that such documents are included in the fields searched

Electronic data base consulted during the international search (name of data base and, where practical, search terms used)

C. DOCUMENTS CONSIDERED TO BE RELEVANT

Category *	Citation of document, with indication, where appropriate, of the relevant passages	Relevant to claim No.
X	DE,A,38 13 409 (OSTERHAGE) 2 November 1989 see column 2, line 67 - column 3, line 41; figures 1-10	1-4,6,7
Y	---	
Y	US,A,4 130 987 (SCHICKEDANZ) 26 December 1978 see claims 1-3,20,23,24,27,28; figures 1-3	1-10
Y	---	
Y	WO,A,90 10897 (GERTSCH) 20 September 1990 see claims 1-4,6,21,22,27,40-42; figures 4,14,15	1-10
A	---	
A	FR,A,2 599 867 (GENNARI) 11 December 1987 see page 2, line 17 - line 35 see page 3, line 12 - line 18	1-3,6
A	---	
A	WO,A,94 04967 (KNODEL) 3 March 1994 see abstract; figures 2,4	1

Further documents are listed in the continuation of box C.

Patent family members are listed in annex.

* Special categories of cited documents :

- 'A' document defining the general state of the art which is not considered to be of particular relevance
- 'E' earlier document but published on or after the international filing date
- 'L' document which may throw doubts on priority claim(s) or which is cited to establish the publication date of another citation or other special reason (as specified)
- 'O' document referring to an oral disclosure, use, exhibition or other means
- 'P' document published prior to the international filing date but later than the priority date claimed

- 'T' later document published after the international filing date or priority date and not in conflict with the application but cited to understand the principle or theory underlying the invention
- 'X' document of particular relevance; the claimed invention cannot be considered novel or cannot be considered to involve an inventive step when the document is taken alone
- 'Y' document of particular relevance; the claimed invention cannot be considered to involve an inventive step when the document is combined with one or more other such documents, such combination being obvious to a person skilled in the art.
- '&' document member of the same patent family

Date of the actual completion of the international search

23 May 1996

Date of mailing of the international search report

05.06.1996

Name and mailing address of the ISA

European Patent Office, P.B. 5818 Patentlaan 2
NL - 2280 HV Rijswijk
Tel. (+ 31-70) 340-2040, Tx. 31 651 epo nl,
Fax (+ 31-70) 340-3016

Authorized officer

Monné, E

INTERNATIONAL SEARCH REPORT

Inter nal Application No PCT/GB 96/00069

Patent document cited in search report	Publication date	Patent family member(s)	Publication date
DE-A-3813409	02-11-89	NONE	
US-A-4130987	26-12-78	DE-A- 2525694	16-12-76
WO-A-9010897	20-09-90	AU-B- 5163890	09-10-90
FR-A-2599867	11-12-87	NONE	
WO-A-9404967	03-03-94	DE-U- 9210786	29-10-92