

(19) World Intellectual Property Organization
International Bureau



(43) International Publication Date
21 July 2011 (21.07.2011)

(10) International Publication Number
WO 2011/086438 A2

(51) International Patent Classification:
A61M 16/06 (2006.01)

(21) International Application Number:
PCT/IB2010/055966

(22) International Filing Date:
20 December 2010 (20.12.2010)

(25) Filing Language: English

(26) Publication Language: English

(30) Priority Data:
61/295,255 15 January 2010 (15.01.2010) US

(71) Applicant (for all designated States except US): **KONINKLIJKE PHILIPS ELECTRONICS N.V.** [NL/NL]; Groenewoudseweg 1, NL-5621 BA Eindhoven (NL).

(72) Inventor; and

(75) Inventor/Applicant (for US only): **HO, Peter, Chi, Fai** [US/US]; P.O. Box 3001, 345 Scarborough Road, Briarcliff Manor, New York 10510-8001 (US).

(74) Agent: **DAMEN, Daniel, M.**; Philips Intellectual Property & Standards, High Tech Campus 44, P.O. Box 220, NL-5600 AE Eindhoven (NL).

(81) Designated States (unless otherwise indicated, for every kind of national protection available): AE, AG, AL, AM, AO, AT, AU, AZ, BA, BB, BG, BH, BR, BW, BY, BZ, CA, CH, CL, CN, CO, CR, CU, CZ, DE, DK, DM, DO,

DZ, EC, EE, EG, ES, FI, GB, GD, GE, GH, GM, GT, HN, HR, HU, ID, IL, IN, IS, JP, KE, KG, KM, KN, KP, KR, KZ, LA, LC, LK, LR, LS, LT, LU, LY, MA, MD, ME, MG, MK, MN, MW, MX, MY, MZ, NA, NG, NI, NO, NZ, OM, PE, PG, PH, PL, PT, RO, RS, RU, SC, SD, SE, SG, SK, SL, SM, ST, SV, SY, TH, TJ, TM, TN, TR, TT, TZ, UA, UG, US, UZ, VC, VN, ZA, ZM, ZW.

(84) Designated States (unless otherwise indicated, for every kind of regional protection available): ARIPO (BW, GH, GM, KE, LR, LS, MW, MZ, NA, SD, SL, SZ, TZ, UG, ZM, ZW), Eurasian (AM, AZ, BY, KG, KZ, MD, RU, TJ, TM), European (AL, AT, BE, BG, CH, CY, CZ, DE, DK, EE, ES, FI, FR, GB, GR, HR, HU, IE, IS, IT, LT, LU, LV, MC, MK, MT, NL, NO, PL, PT, RO, RS, SE, SI, SK, SM, TR), OAPI (BF, BJ, CF, CG, CI, CM, GA, GN, GQ, GW, ML, MR, NE, SN, TD, TG).

Declarations under Rule 4.17:

- as to applicant's entitlement to apply for and be granted a patent (Rule 4.17(ii))
- as to the applicant's entitlement to claim the priority of the earlier application (Rule 4.17(iii))

Published:

- without international search report and to be republished upon receipt of that report (Rule 48.2(g))

(54) Title: REPLACEABLE NASAL PILLOW

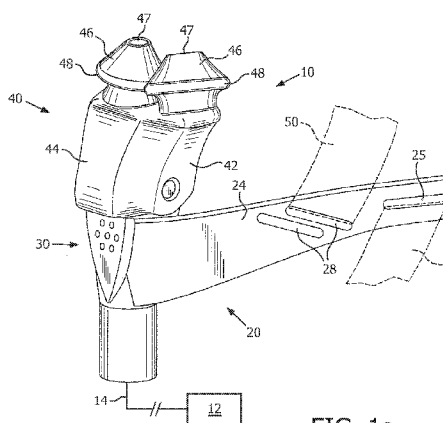

FIG. 1a

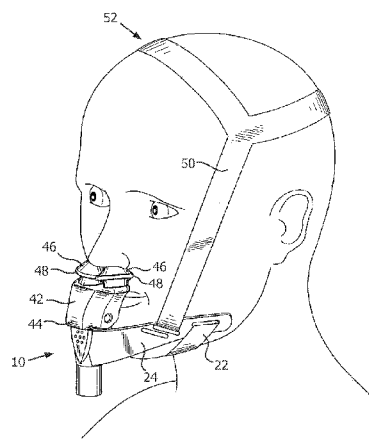

FIG. 1b

(57) Abstract: A replaceable nasal pillow for use in a patient interface device, the nasal pillow comprising: a base portion, a casing, and a fill material. The base portion is structured to be disposed on a portion of the patient interface device. The casing is coupled to the base in a manner that defines a sealed cavity therein. The casing includes an inner portion and an outer portion that is structured to sealingly engage a nare of a patient. The fill material is disposed in the sealed cavity defined by the casing and the base.



WO 2011/086438 A2

REPLACEABLE NASAL PILLOW

- [01] This patent application claims the priority benefit under 35 U.S.C. § 119(e) of U.S. Provisional Application No. 61/295,255 filed on January 15, 2010, the contents of which are herein incorporated by reference.
- [02] The present invention pertains to patient interface devices, and, in particular, to patient interface devices having replaceable nasal pillows.
- [03] There are numerous situations where it is necessary or desirable to deliver a flow of breathing gas non-invasively to the airway of a patient, i.e., without intubating the patient or surgically inserting a tracheal tube in the esophagus. For example, it is known to ventilate a patient using a technique known as non-invasive ventilation. It is also known to deliver continuous positive airway pressure (CPAP) or variable airway pressure, such as a bi-level pressure that varies with the patient's respiratory cycle or an auto-titrating pressure that varies with the monitored condition of the patient. Typical pressure support therapies are provided to treat a medical disorder, such as sleep apnea syndrome, in particular, obstructive sleep apnea (OSA), or congestive heart failure.
- [04] Non-invasive ventilation and pressure support therapies involve the placement of a patient interface device, which is typically a nasal or nasal/oral mask, on the face of a patient to interface the ventilator or pressure support system with the airway of the patient so that a flow of breathing gas can be delivered from the pressure/flow generating device to the airway of the patient. It is known to maintain such masks on the face of a patient by a headgear having upper and lower straps, each having opposite ends threaded through connecting elements provided on the opposite sides and top of a mask.
- [05] Because such masks are typically worn for an extended period of time, a variety of concerns must be taken into consideration. For example, in providing CPAP to treat OSA, the patient normally wears the patient interface device all night long while he or she sleeps. One concern in such a situation is that the patient interface device is as comfortable as possible, otherwise the patient may avoid wearing the interface device, defeating the purpose of the prescribed pressure support therapy. It is also important that the interface device provides a tight enough seal against a patient without discomfort.

- [06] In general, patients using a mask interface under ventilation require a specifically sized mask to fit the dimensions of the patients facial features. This is also true for patients who use nasal pillows where sizing is less obvious, and therefore can more commonly occur, than in applications where a conventional triangular interface is used. Providers generally attempt to address fitment problems by giving the patient a number of masks with various sizes to pick from. Such solution can become quite cumbersome in application involving multiple large size masks and confusing. Such solution also fails to address a further issue of patients with asymmetric nostrils..
- [07] Therefore, an advantage exists for a patient interface employing nasal pillows that may be readily sized to a particular patient, including those with asymmetric nostrils. A further advantage exists for such an interface that can accomplish such features while additionally improving user comfort
- [08] Accordingly, it is an object of the present invention to provide a patient interface device that overcomes shortcomings of conventional patient interface device. This object is achieved according to one embodiment of the present invention by providing a patient interface device comprising a body portion and a patient interface portion. The body portion comprises a pair of arms and a chin support, wherein a first end portion of each arm in the pair of arms is coupled to an opposite end of the chin support, and wherein the chin support is adapted to be disposed under the mandible responsive to the patient interface device being donned by a user. The body portion further comprises at least one headgear attachment and a circuit portion operatively coupled to a second end portion of each arm in the pair of arms. The patient interface portion is operatively coupled to the circuit portion. The patient interface portion comprises a cushion and a replaceable nasal pillow. The cushion includes a base portion and a platform portion, the base portion is structured to couple the cushion to the body portion of the patient interface device. The replaceable nasal pillow is disposed on, and is selectively coupled to, the platform portion of the cushion. A portion of the nasal pillow is structured to sealingly engage a nare (nostril) of a patient.
- [09] According to another embodiment of the invention, a patient interface for use in a patient interface device for delivering a flow of gas to a patient is provided. The

patient interface device includes a body portion. The patient interface comprises a cushion and a replaceable nasal pillow. The cushion includes a base portion and a platform portion. The base portion is structured to couple the cushion to the body portion of the patient interface device. The replaceable nasal pillow is disposed on, and selectively coupled to, the platform portion of the cushion. A portion of the nasal pillow is structured to sealingly engage a nare of a patient.

[10] According to a further embodiment of the invention a replaceable nasal pillow for use in a patient interface device is provided. The nasal pillow comprising a base portion, a casing and a fill material. The base portion is structured to be disposed on a portion of the patient interface device. The casing is coupled to the base in a manner which defines a sealed cavity therein. The casing includes an inner portion and an outer portion structured to sealingly engage a nare (nostril) of a patient. The fill material is disposed in the sealed cavity defined by the casing and the base portion.

[11] These and other objects, features, and characteristics of the present invention, as well as the methods of operation and functions of the related elements of structure and the combination of parts and economies of manufacture, will become more apparent upon consideration of the following description and the appended claims with reference to the accompanying drawings, all of which form a part of this specification, wherein like reference numerals designate corresponding parts in the various figures. It is to be expressly understood, however, that the drawings are for the purpose of illustration and description only and are not intended as a definition of the limits of the invention. As used in the specification and in the claims, the singular form of “a”, “an”, and “the” include plural referents unless the context clearly dictates otherwise.

[12] FIG. 1a is a front perspective view of a first embodiment of a patient interface device according to the principles of the present invention;

[13] FIG. 1b is a front perspective view illustrating the positioning of the patient interface device of FIG. 1a on a user;

[14] FIGS. 2-4 are front, side, and rear views, respectively, of the patient interface device of FIG. 1a;

[15] FIG. 5 is a front exploded view of the patient interface device of FIG. 1a;

[16] FIG. 6 is a side view, of the body portion of the patient interface device of FIG. 5;

[17] FIG. 7 is a cross-sectional view of an embodiment of a replaceable nasal pillow installed on a portion of a corresponding platform according to the principles of the present invention;

[18] FIG. 8 is an exploded cross-sectional view of the replaceable nasal pillow and platform of FIG. 7;

[19] FIG. 9 is a cross-sectional view of another embodiment of a replaceable nasal pillow installed on a portion of a corresponding platform according to the principles of the present invention;

[20] FIG. 10 is a cross-sectional view of another embodiment of a replaceable nasal pillow installed on a portion of a corresponding platform according to the principles of the present invention;

[21] FIG. 11 is a cross-sectional view of another embodiment of a replaceable nasal pillow installed on a portion of a corresponding platform according to the principles of the present invention;

[22] FIG. 12 is an exploded view of the replaceable nasal pillow and platform of FIG. 11;

[23] FIG. 13 is a partial cross-sectional view of another embodiment of a replaceable nasal pillow installed on a portion of a corresponding platform according to the principles of the present invention;

[24] FIG. 14 is an elevational view of the platform of FIG. 13;

[25] FIG. 15 is a cross-sectional view of another embodiment of a replaceable nasal pillow installed on a portion of a corresponding platform according to the principles of the present invention;

[26] FIG. 16 is a cross-sectional view of another embodiment of a nasal pillow to be used in conjunction with the platform of FIG. 15;

[27] FIG. 17 is cross-sectional view of an embodiment of a replaceable nasal pillow installed on a portion of a corresponding platform according to the principles of the present invention;

- [28] FIG. 18 is an isometric exploded view of the replaceable nasal pillow and platform of FIG. 17; and
- [29] FIGS. 19-20 are cross-sectional views of further embodiments of a replaceable nasal pillow installed on a portion of a corresponding platform according to the principles of the present invention.
- [30] FIGS. 1a, 1b and 2-6 illustrate a general overview of an embodiment of the invention employed in conjunction with an example base member, such as described in U.S. Patent No. 7,500,480, the contents of which are hereby incorporated herein. It is to be appreciated that such base member 20 is provided for example purposes only as the present invention may be readily employed with a variety of base members and nasal cannula systems.
- [31] Referring to FIG. 1a, patient interface device 10 is shown schematically connected to a pressure support system 12 via a patient circuit 14, which communicates gas from the pressure support system 12 to the patient interface device 10. Patient circuit 14 is any device, such as a flexible tubing, that carries the flow of gas from the pressure/flow generator in the pressure support system to the patient interface device 10.
- [32] Pressure support system 12 is any conventional ventilation or pressure support system. Examples of such pressure support systems include, but are not limited to: a ventilator, continuous positive airway pressure (CPAP) device, or a variable pressure device, e.g. an auto-titrating device, proportional assist ventilation (PAV[®]) device, proportional positive airway pressure (PPAP[®]) device, C-Flex[™] device, Bi-Flex[™] device, or a BiPAP[®] device manufactured and distributed by Respironics, Inc. of Pittsburgh, PA, in which the pressure provided to the patient varies with the patient's respiratory cycle so that a higher pressure is delivered during inspiration than during expiration, or other pressure support device.
- [33] Continuing to refer to FIG. 1a, and additionally to FIGS. 2-4, patient interface device 10 includes a body portion 20, a circuit portion 30, and a patient interface portion 40. Body portion 20 includes a chin support 22 and a pair of arms 24. In the illustrated exemplary embodiment, circuit portion 30 and body portion 20 are integral with one another so that a gas flow path is defined through the patient interface

device 10. Arms 24 include multiple headgear attachment elements 28 in the form of slots that are angled to match the angle of attachment of a headgear strap 50 when the patient interface device 10 is worn by the user. Attachment structures 25, also in the form of slots, are provided at the ends of arms 24. Chin support 22, which is a flexible strap, inserts through these slots. Typically, this chin strap is a padded strap that passes through the attachment structures 25 and loops back on itself. A hook and loop or other suitable fastener is generally provided on the strap so that the length of the strap may be adjusted.

[34] Patient interface portion 40 includes a cushion 42 that attaches to circuit portion 30. Cushion 42 can be made from any suitable material, such as gel, silicone, foam, rubber, or a combination of materials and includes a base 44 and a pair of replaceable nasal pillows 46, each selectively coupled about an nasal aperture 47 in corresponding platforms 48 disposed generally along a top of cushion 42. As used here, the phrase “selectively coupled” shall be used to describe a coupling between at least two members such that the members may be uncoupled and coupled again without damaging either of the members. The structure of the replaceable nasal pillows 46 and cushion 42 will be discussed in further detail below in conjunction with a number of exemplary embodiments of the present invention.

[35] A best shown in FIGS. 5 and 6, circuit portion 30 includes a cushion attachment member 32 to which cushion 42 attaches in a male-female configuration. A cavity 45 (FIG. 5) is defined in base 44 of cushion 42 having a shape that generally matches the shape of cushion attachment member 32. As shown in FIG. 5, cavity 45 extends upward to each of nasal apertures 47. The cushion attaches to the circuit portion by sliding the base over cushion attachment member 32. The flexibility of the base 44 allows it to flex around the cushion attachment member 32 and the resiliency of the base 44 maintains the attachment.

[36] In the illustrated embodiment, cushion attachment member 32 has a barrel shape (and the cavity in the cushion has a similar barrel shape) so that the cushion can be moved or rotated relative to body portion 20 as indicated by arrow 33 in FIG. 3. The barrel shape, unlike a ball-and-socket, allows movement (rotation) in only one plane.

Optional pins 34 can be provided on the sides (ends) of the barrel to help maintain the attachment between the cushion and the cushion attachment member 32 and allow the user to rotate the cushion about a fixed point and without dislodging it from the cushion attachment member. A passage 36 is defined through circuit portion 30, including through cushion attachment member 32. An opening 38 (FIG. 5) is defined in the top of cushion attachment member 32 so that gas flows between circuit portion 30 and cushion 42.

[37] As shown in FIG. 1b, when patient interface device 10 is donned by the user, chin support 22 passes under the mandible from one side of the patients face to the other. A headgear assembly 52 including straps 50 maintain the patient interface device on the user. The two regions of the patient's face that primarily support the patient interface device on the user are the chin (via the chin support) and the patient's nasal region and/or nasal openings (via the patient interface portion) where each replaceable nasal pillow 46 sealingly engages a nare of the patient such that the flow of gas is provided to the patient from the pressure support system via patient circuit 14, circuit portion 30, and finally cavity 45 through nasal aperture 47.

[38] Having thus described a general overview of an example of a patient interface device 10 according to the present invention, a first exemplary embodiment of a replaceable nasal pillow 46 and corresponding platform 48 will now be described in conjunction with FIGS. 7 and 8 which show assembled and exploded cross-sectional views, respectively, of the combination. Nasal pillow 46 includes a generally flat, ring-like base member 62 and a casing 64 coupled to base member 62, to form a generally frusto-conical ring member defining a space (not numbered). Nasal pillow 46 further includes a fill material 66 disposed within the space formed by the assembly of base member 62 and casing 64. In the exemplary embodiment depicted, casing 64, and similarly the further embodiments thereof discussed herein, is formed from a generally thin flexible material (e.g., without limitation, silicone, polyurethane, thermal plastic elastomer, poly vinyl chloride, natural rubber) and includes a generally outer portion 65 and a generally inner portion 67.

[39] Base member 62, as well as the further embodiments thereof discussed herein, is generally formed from a similar material as casing 64 or a somewhat more rigid material such as a thermal plastic, e.g., without limitation, Polycarbonate (PC), Polypropylene (PP), and Polystyrene (PS). Fill material 66 generally consists of a gel or other suitable material that generally conforms to the space defined by base 62 and casing 64 and allows for outer portion 65 of casing 64 to flex and conform to a nare of a patient. Inner portion 67 of casing 64 includes a thickened portion 70 that serves as a retention mechanism that cooperatively engages a corresponding retention mechanism (discussed below) of a platform 48 to selectively couple nasal pillow 46 to platform 48.

[40] Continuing to refer to FIGS. 7 and 8, platform 48 includes a generally planar shelf portion 72 having a generally ring-like shape that encircles a generally tubular chimney portion 74 that extends upward from planar portion 72 and terminates at a top opening 78. Chimney portion 74 includes a reduced diameter portion 76 sized such that when nasal pillow 46 is installed on platform 48, thickened portion 70 of nasal pillow 46 cooperatively engages reduced diameter portion 76 (shown in FIG. 7) in a manner that selectively couples nasal pillow 46 to platform 48. It is to be appreciated that the relatively flexible nature of one or both of nasal pillow 46 and/or platform 48 allows for nasal pillow 46 to be “snapped” over opening 78 and onto platform 74 in a coupled position or “unsnapped” upon removal from platform 48 into an uncoupled position. It is contemplated that thickened portion 70 may extend along all (shown), or a portion of (not shown), inner portion 67 about chimney portion 74. Similarly, it is also contemplated that reduced diameter portion 76 may extend around all (shown), or selected portions of (not shown) chimney portion 74 as long as such reduced diameter portions 76 are provided, at minimum, in sufficient locations to cooperatively engage corresponding thickened portions 70 of nasal pillow 46.

[41] FIG. 9 illustrates a cross-sectional view of a second embodiment of a replaceable nasal pillow 146 installed on a corresponding platform 148 according to the principles of the present invention. Similar to the previous embodiment, nasal pillow 146 includes a generally flat, ring-like base member 162 and a casing 164 coupled to base member 162, to form a generally frusto-conical ring member defining a space (not

numbered) within. Nasal pillow 146 further includes a fill material 166 disposed within the space formed by the assembly of base member 162 and casing 164. In the exemplary embodiment depicted, casing 164 is formed from a generally thin flexible material, such as previously discussed, and includes a generally outer portion 165 and a generally inner portion 167. Base member 162 is formed from a somewhat harder yet generally flexible material, such as previously discussed. Fill material 166 generally consists of a gel or other suitable material that generally conforms to the space defined by base 162 and casing 164 and allows for outer portion 165 of casing 164 to flex and conform to a nare of a patient. Inner portion 167 of casing 164 includes a thickened portion 170 that serves as a retention mechanism that cooperatively engages a corresponding retention mechanism (discussed below) of a platform 148 to selectively couple nasal pillow 146 to platform 148. Inner portion 167 of casing 164 includes a thickened portion 170 that serves as a retention mechanism that cooperatively engages a corresponding retention mechanism (discussed below) of a platform 148 to selectively couple nasal pillow 146 to platform 148.

[42] Continuing to refer to FIG. 9, platform 148 includes a generally planar shelf portion 172 having a generally ring-like shape that encircles a generally tubular chimney portion 174 that extends upward from planar portion 172 and terminates at a top opening 178. Chimney portion 174 includes a reduced diameter portion 176 sized such that when nasal pillow 146 is installed on platform 148, thickened portion 170 of nasal pillow 146 cooperatively engages reduced diameter portion 176 in a manner that selectively couples nasal pillow 146 to platform 148. It is to be appreciated that the relatively flexible nature of one or both of nasal pillow 146 and/or platform 148 allows for nasal pillow 146 to be “snapped” over opening 178 and onto platform 174 in a coupled position or “unsnapped” upon removal from platform 148 into an uncoupled position. It is contemplated that thickened portion 170 may extend along all (not shown), or a portion of (shown), inner portion 167 about chimney portion 174. Similarly, it is also contemplated that reduced diameter portion 176 may extend around all (not shown), or selected portions of (shown) chimney portion 174 as long as such reduced diameter

portions 176 are provided, at minimum, in sufficient locations to cooperatively engage corresponding thickened portions 170 of nasal pillow 146.

[43] In addition to the cooperative engagement of thickened portion 170 and reduced diameter portion 176, the embodiment depicted in FIG. 9 further includes an additional retention mechanism serving to selectively couple nasal pillow 146 to platform 148. Such additional retention mechanism is provided by a hooked portion 169 of casing 164 that extends below, and generally hooks around an end portion 173 of planar portion 172 when nasal pillow 146 is fully installed on platform 148.

[44] FIG. 10 illustrates a cross-sectional view of a third embodiment of a replaceable nasal pillow 246 installed on a corresponding platform 248 according to the principles of the present invention. Similar to the previous embodiment, nasal pillow 246 includes a generally flat, ring-like base member 262 and a casing 264 coupled to base member 262, to form a generally frusto-conical ring member defining a space (not numbered) within. Nasal pillow 246 further includes a fill material 266 disposed within the space formed by the assembly of base member 262 and casing 264. In the exemplary embodiment depicted, casing 264 is formed from a generally thin flexible material and includes a generally outer portion 265 and a generally inner portion 267. Base member 262 is formed from a somewhat harder yet generally flexible material. Fill material 266 generally consists of a gel or other suitable material that generally conforms to the space defined by base 262 and casing 264 and allows for outer portion 265 of casing 264 to flex and conform to a nare of a patient. Base 262 may further be coupled to fill material 266 by an adhesive layer 261 in applications where a fill material 266 suitable for such bonding is employed. It is to be appreciated that such coupling between the base and fill material may further be employed with any of the embodiments described herein when a suitable fill material is employed.

[45] Base member 262 includes a vertical portion 263 adjacent inner portion 267 of casing 264 that serves as a retention mechanism that cooperatively engages a portion (discussed below) of a platform 248 to selectively couple nasal pillow 246 to platform 248.

[46] Continuing to refer to FIG. 10, platform 248 includes a generally planar shelf portion 272 having a generally ring-like shape that encircles a generally tubular chimney portion 274 that extends upward from planar portion 272 and terminates at a top opening 278. Chimney portion 274 includes is generally sized such that when nasal pillow 246 is installed on platform 248, an interference fit is produced between chimney portion 274 and base member 262, particularly between chimney portion 274 and vertical portion 263 of base member 262. Such interference fit is provided in part due to the relative stiffness of base member 262 (and vertical portion 263 thereof) in comparison with the other materials of nasal pillow 246. It is to be appreciated that such interference fit allows for nasal pillow 246 to be forcibly slid onto platform 248 in a coupled position or forcibly removed from platform 248 to be uncoupled. It is contemplated that vertical portion 263 of base member 262 may extend along all (not shown), or a portion of (shown), base member 262 about chimney portion 274.

[47] FIGS. 11 and 12 illustrate assembled and exploded cross-sectional views, respectively, of a fourth embodiment of a replaceable nasal pillow 346 and corresponding platform 348 according to the principles of the present invention. Nasal pillow 346 includes a generally flat, ring-like base member 362 and a casing 364 coupled to base member 362, to form a generally frusto-conical ring member defining a space (not numbered). Nasal pillow 346 further includes a fill material 366 disposed within the space formed by the assembly of base member 362 and casing 364. In the exemplary embodiment depicted, casing 364 is formed from a generally thin flexible material and includes a generally outer portion 365 and a generally inner portion 367. Base member 362 is formed from a similar or somewhat harder yet generally flexible material. Fill material 366 generally consists of a gel or other suitable material that generally conforms to the space defined by base 362 and casing 364 and allows for outer portion 365 of casing 364 to flex and conform to a nare of a patient. Base portion 362 includes a downward facing hook portion 363 that serves as a retention mechanism that cooperatively engages a corresponding retention mechanism (discussed below) of a platform 348 to selectively couple nasal pillow 346 to platform 348.

[48] Continuing to refer to FIGS. 11 and 12, platform 348 includes a generally planar shelf portion 372 having a generally ring-like shape. Planar shelf portion 372 includes an inward directed portion 373 defining an opening 378 sized such that when nasal pillow 346 is installed on platform 348, downward facing hook portion 363 of nasal pillow 346 cooperatively engages inward directed portion 373 of shelf portion 372 (FIG. 11) in a manner that selectively couples nasal pillow 346 to platform 348. It is to be appreciated that the relatively flexible nature of one or both of nasal pillow base 362 and/or planar shelf portion 372 allows for downward facing hook portion 363 of nasal pillow 346 to be “snapped” into opening 378 of platform 374, thus coupling nasal pillow 346 to platform 348, or “unsnapped” upon removal from platform 348 into an uncoupled position. It is contemplated that downward facing hook portion 363 may extend completely around (shown), or around a portion of (not shown), inner base portion 362. Similarly, it is also contemplated that inward directed portion 373 may extend inward from around all (shown), or selected portions of (not shown), planar shelf portion 372 as long as such inward directed portions 373 are provided, at minimum, in sufficient locations to cooperatively engage corresponding downward facing hook portions 363 of nasal pillow 346.

[49] FIGS. 13 and 14 illustrate a partial cross-sectional view of a fifth embodiment of a replaceable nasal pillow 446 installed on a corresponding platform 448 and an elevation view of platform 448, respectively, according to the principles of the present invention. Nasal pillow 446 includes a generally flat, ring-like base member 462 and a casing 464 coupled to base member 462, to form a generally frusto-conical ring member defining a space (not numbered). Nasal pillow 446 further includes a fill material 466 disposed within the space formed by the assembly of base member 462 and casing 464. In the exemplary embodiment depicted, casing 464 is formed from a generally thin flexible material and includes a generally outer portion 465 and a generally inner portion 467. Base member 462 is formed from a similar or somewhat harder yet generally flexible material such. Fill material 466 generally consists of a gel or other suitable material that generally conforms to the space defined by base 462 and casing 464 and allows for outer portion 465 of casing 464 to flex and conform to a nare of a patient.

Inner portion 467 of casing 464 includes a grooved portion 470 that serves as a retention mechanism that cooperatively engages a corresponding retention mechanism (discussed below) of a platform 448 to selectively couple nasal pillow 446 to platform 448.

[50] Continuing to refer to FIGS. 13 and 14, platform 448 includes a generally planar shelf portion 472 having a generally ring-like shape that encircles a generally tubular chimney portion 474 that extends upward from planar portion 472 and terminates at a top opening 478. Chimney portion 474 includes a rib portion 476 sized such that when nasal pillow 446 is installed on platform 448, grooved portion 470 of nasal pillow 446 cooperatively engages rib portion 476 in a manner that selectively couples nasal pillow 446 to platform 448. It is to be appreciated that the relatively flexible nature of one or both of nasal pillow 446 and/or platform 448 allows for nasal pillow 446 to be “snapped” over opening 478 and onto platform 474 in a coupled position or “unsnapped” upon removal from platform 448 into an uncoupled position. It is contemplated that grooved portion 470 may extend along all or a portion of inner portion 467 about chimney portion 474. Similarly, it is also contemplated that rib portion 476 may extend around all (shown), or selected portions of (not shown) chimney portion 474 as long as such grooved portions 470 are provided, at minimum, in sufficient locations to cooperatively engage corresponding rib portions 476 of chimney portion 474.

[51] FIG. 15 illustrates a cross-sectional view of a sixth embodiment of a replaceable nasal pillow 546 installed on a corresponding platform 548 according to the principles of the present invention. Nasal pillow 546 includes a generally flat, ring-like base member 562 and a casing 564 coupled to base member 562, to form a generally frusto-conical ring member defining a space (not numbered) within. Nasal pillow 546 further includes a fill material 266 disposed within the space formed by the assembly of base member 562 and casing 564. In the exemplary embodiment depicted, casing 564 is formed from a generally thin flexible material and includes a generally outer portion 565 and a generally inner portion 567. Base member 562 is formed from a similar or somewhat harder yet generally flexible material such as. Fill material 566 generally consists of a gel or other suitable material that generally conforms to the space defined by

base 562 and casing 564 and allows for outer portion 565 of casing 564 to flex and conform to a nare of a patient.

[52] Base portion of nasal pillow 546 further includes an inner member 563 of generally tubular shape coupled to inner portion 567 of casing 564. Inner member 563 extends downward from base member 562 and terminates in a hook portion 563A that serves as a retention mechanism that cooperatively engages a portion (discussed below) of a platform 548 to selectively couple nasal pillow 546 to platform 548.

[53] Continuing to refer to FIG. 15, platform 548 includes a generally planar shelf portion 572 having a generally ring-like shape. Planar shelf portion 572 includes an inward directed portion 573 defining an opening 578 sized such that when nasal pillow 546 is installed on platform 548, hook portion 563A of inner member 563 cooperatively engages inward directed portion 573 of shelf portion 572 in a manner that selectively couples nasal pillow 546 to platform 548. It is to be appreciated that the relatively flexible nature of one or both of nasal pillow base 562 and/or planar shelf portion 572 allows for hook portion 563A of nasal pillow 546 to be “snapped” into opening 578 of platform 574, thus coupling nasal pillow 546 to platform 548, or “unsnapped” upon removal from platform 548 into an uncoupled position. It is contemplated that hook portion 563A may extend completely around (shown), or around a portion of (not shown), inner member 563. Similarly, it is also contemplated that inward directed portion 573 may extend inward from around all (shown), or selected portions of (not shown), planar shelf portion 572 as long as such inward directed portions 573 are provided, at minimum, in sufficient locations to cooperatively engage corresponding hook portions 563A of nasal pillow 546.

[54] FIG. 16 illustrates a cross-sectional view of a seventh embodiment of a replaceable nasal pillow 646 installed on a corresponding platform 648 according to the principles of the present invention. Nasal pillow 646 includes a casing 664 forming a generally frusto-conical ring member defining a space (not numbered) below. In the exemplary embodiment depicted, casing 564 is formed from a generally thin flexible material and includes a generally outer portion 665 and a generally inner portion 667.

Outer portion 665 of casing 664 is generally configured to flex and conform to a nare of a patient.

[55] Nasal pillow 646 further includes an inner member 662 of generally tubular shape coupled to inner portion 667 of casing 664. Inner member 662 extends downward from inner portion 667 and terminates in a hook portion 663 that serves as a retention mechanism that cooperatively engages a portion (discussed below) of a platform 648 to selectively couple nasal pillow 646 to platform 648.

[56] Continuing to refer to FIG. 16, platform 648 includes a generally planar shelf portion 672 having a generally ring-like shape. Shelf portion 672 includes an inward directed portion 673 defining an opening 678 sized such that when nasal pillow 646 is installed on platform 648, hook portion 663 of inner member 662 cooperatively engages inward directed portion 673 of shelf portion 672 in a manner that selectively couples nasal pillow 546 to platform 648. It is to be appreciated that the relatively flexible nature of one or both of nasal inner member 662 and/or planar shelf portion 672 allows for hook portion 663 of nasal pillow 646 to be “snapped” into opening 678 of platform 674, thus coupling nasal pillow 646 to platform 648, or “unsnapped” upon removal from platform 648 into an uncoupled position. It is contemplated that hook portion 663 may extend completely around (shown), or around a portion of (not shown), inner member 662. Similarly, it is also contemplated that inward directed portion 673 may extend inward from around all (shown), or selected portions of (not shown), planar shelf portion 672 as long as such inward directed portions 673 are provided, at minimum, in sufficient locations to cooperatively engage corresponding hook portions 663 of nasal pillow 646.

[57] FIGS. 17 and 18 illustrate an assembled cross-sectional view and an isometric exploded view, respectively, of an eighth embodiment of a replaceable nasal pillow 746 and corresponding platform 748 according to the principles of the present invention. Nasal pillow 746 includes a generally flat, ring-like base member 762 and a casing 764 coupled to base member 762, to form a generally frusto-conical ring member defining a space (not numbered). Nasal pillow 746 further includes a fill material 766 disposed within the space formed by the assembly of base member 762 and casing 764.

In the exemplary embodiment depicted, casing 764 is formed from a generally thin flexible material and includes a generally outer portion 765 and a generally inner portion 767. Base member 762 is formed from a similar or somewhat harder yet generally flexible material. Fill material 766 generally consists of a gel or other suitable material that generally conforms to the space defined by base 762 and casing 764 and allows for outer portion 765 of casing 764 to flex and conform to a nare of a patient.

[58] Nasal pillow 746 further includes an inner member 763 of generally tubular shape coupled to inner portion 767 of casing 764. Inner member 763 extends downward from base member 762 and includes a number of apertures 775 that serve as a retention mechanism that cooperatively engages a portion (discussed below) of a platform 748 to selectively couple nasal pillow 746 to platform 748.

[59] Continuing to refer to FIGS. 17 and 18, platform 748 includes a generally planar shelf portion 772 having a generally ring-like shape. Shelf portion 772 includes a number of protrusions 773 directed inward from shelf portion 772 toward an opening 778 that, when nasal pillow 746 is installed on platform 748, cooperatively engage each of the number of apertures 775 of nasal pillow 746 in a manner that selectively couples nasal pillow 746 to platform 748. It is to be appreciated that the relatively flexible nature of one or both of inner member 763 and/or planar shelf portion 772 allows for inner member 763 of nasal pillow 746 to be “snapped” into opening 778 of platform 774, thus coupling nasal pillow 746 to platform 748, or “unsnapped” upon removal from platform 748 into an uncoupled position. Although shown having four protrusions 773, it is to be appreciated that the number and relative sizing of such protrusions 773 may vary within the scope of the present invention.

[60] FIG. 19 illustrates a cross-sectional view of a ninth embodiment of a replaceable nasal pillow 846 installed on a corresponding platform 848 according to the principles of the present invention. Nasal pillow 846 includes a generally flat, ring-like base member 862 and a casing 864 coupled to base member 862, to form a generally frusto-conical ring member defining a space (not numbered). Nasal pillow 846 further includes a fill material 866 disposed within the space formed by the assembly of base member 862 and casing 864. In the exemplary embodiment depicted, casing 864 is

formed from a generally thin flexible material and includes a generally outer portion 865 and a generally inner portion 867. Base member 862 is formed from a similar or somewhat harder yet generally flexible material. Fill material 866 generally consists of a gel or other suitable material that generally conforms to the space defined by base 862 and casing 864 and allows for outer portion 865 of casing 864 to flex and conform to a nare of a patient.

[61] Continuing to refer to FIG. 19, platform 848 includes a generally planar shelf portion 872 having a generally ring-like shape that encircles a generally tubular chimney portion 874 that extends upward from planar portion 872 and terminates at a top opening 878. Chimney portion 874 includes a rib portion 876 adjacent top opening 878 and sized such that when nasal pillow 846 is installed on platform 848, rib portion 876 engages an uppermost portion (not numbered) of inner portion 867 in a manner that selectively couples nasal pillow 846 to platform 848. It is to be appreciated that the relatively flexible nature of one or both of nasal pillow 846 and/or chimney portion 874 allows for nasal pillow 846 to be “snapped” over rib portion 876 and onto platform 874 in a coupled position or “unsnapped” upon removal from platform 848 into an uncoupled position. It is contemplated that rib portion 876 may extend about all (shown), or a portion of (not shown), tubular chimney portion 874.

[62] Although the invention has been described in detail for the purpose of illustration based on what is currently considered to be the most practical and preferred embodiments, it is to be understood that such detail is solely for that purpose and that the invention is not limited to the disclosed embodiments, but, on the contrary, is intended to cover modifications and equivalent arrangements that are within the scope of the appended claims. For example, it is to be understood that the present invention contemplates that, to the extent possible, one or more features of any embodiment can be combined with one or more features of any other embodiment. In the claims, any reference signs placed between parentheses shall not be construed as limiting the claim. The word "comprising" or “including” does not exclude the presence of elements or steps other than those listed in a claim. In any device claim enumerating several means, several of these means may be embodied by one and the same item of hardware.

What is Claimed is:

1. A replaceable nasal pillow (46) for use in a patient interface device (10), the nasal pillow comprising:
 - a base portion (62) structured to be coupled to a body portion of such a patient interface device;
 - a casing (64) coupled to the base portion in a manner which defines a sealed cavity therein, the casing having an outer portion (65) structured to sealingly engage a nare of a patient and an inner portion (67); and
 - a fill material (66) disposed in the sealed cavity defined by the casing and the base portion.
2. The replaceable nasal pillow of claim 1, wherein the inner portion of the casing comprises a thickened portion (70) that is structured to cooperatively engage a portion of the body portion.
3. The replaceable nasal pillow of claim 2, wherein the outer portion of the casing comprises a hooked portion (169) that is structured to extend below, and generally hook around a portion (173) of the body portion.
4. The replaceable nasal pillow of claim 1, wherein the base portion comprises a vertical portion adjacent the inner portion of the casing that is structured to engage as an interference fit a portion of the body portion.
5. The replaceable nasal pillow of claim 1, wherein the base portion comprises a downward facing hook portion (363) that is structured to engage a portion (373) of the body portion.

6. The replaceable nasal pillow of claim 1, wherein the inner portion (467) of the casing comprises a grooved portion (470) that is structured to cooperatively engage a rib portion (476) of the body portion.

7. The replaceable nasal pillow of claim 1, wherein the base portion comprises an inner member (563) of generally tubular shape coupled to the inner portion of the casing, the inner member extending downward from the base portion and terminating in a hook portion (563A) that is structured to cooperatively engage a portion of the body portion.

8. The replaceable nasal pillow of claim 1, wherein the base portion comprises an inner member of generally tubular shape coupled to inner portion of the casing, the inner member extending downward from the base portion and having an aperture (775) disposed therein that is structured to cooperatively engage a portion (773) of the body portion.

9. The replaceable nasal pillow of claim 1, wherein an upper portion of the inner portion of the casing is structured to cooperatively engage a portion of the body portion.

10. A patient interface portion (40) for use in a patient interface device (10) for delivering a flow of gas to a patient, the patient interface device (10) having a body portion (20), the patient interface portion (40) comprising:

a cushion (42) having a base portion (44) and a platform portion (48), the base portion being structured to couple the cushion to the body portion of the patient interface device; and

a replaceable nasal pillow (46) disposed on, and selectively coupled to the platform portion (48) of the cushion, a portion (65) of the nasal pillow being structured to sealingly engage a nare of a patient.

11. The patient interface of claim 10, wherein the nasal pillow comprises:
a base portion (62) disposed on the platform portion of the cushion;
a casing (64) coupled to the base portion in a manner which defines a sealed cavity therein, the casing having an outer portion (65) structured to sealingly engage a nare of a patient, and an inner portion (67); and
a fill material (66) disposed in the sealed cavity defined by the casing and the base.

12. The patient interface of claim 11, wherein the platform portion of the cushion comprises a generally tubular chimney portion (74) that includes a reduced diameter portion (76), and wherein the inner portion of the casing comprises a thickened portion (70) that cooperatively engages the reduced diameter portion of the tubular chimney portion in a manner that selectively couples the nasal pillow to the body portion.

13. The patient interface of claim 12, wherein the outer portion of the casing comprises a hooked portion (169) that extend below, and generally hooks around a portion (173) of the platform portion in a manner that selectively couples the nasal pillow to the cushion.

14. The patient interface of claim 11, wherein the platform portion comprises a generally tubular chimney portion (274), and wherein the base portion comprises a vertical portion (263) adjacent the inner portion of the casing that engages as an interference fit the chimney portion in a manner that selectively couples the nasal pillow to the platform portion.

15. The patient interface of claim 11, wherein the platform portion comprises a planar shelf portion (372) having an inward directed portion (373), and wherein the base portion comprises a downward facing hook portion (363) that engages the inward directed portion of the shelf portion in a manner that selectively couples the nasal pillow to the platform portion.

16. The patient interface of claim 11, wherein the platform portion comprises a generally tubular chimney portion (474) having a rib portion (476), and wherein the inner portion of the casing comprises a grooved portion (470) that cooperatively engages the rib portion in a manner that selectively couples the nasal pillow to the platform portion.

17. The patient interface of claim 11, wherein the platform portion comprises a planar shelf portion (572) having an inward directed portion (573), and wherein the base portion comprises an inner member (563) of generally tubular shape coupled to the inner portion of the casing, the inner member extending downward from the base portion and terminating in a hook portion (563A) that cooperatively engages the inward directed portion of the platform portion in a manner that selectively couples the nasal pillow to the platform portion.

18. The patient interface of claim 11, wherein the platform portion comprises a planar shelf portion (772) having a protrusion (773) directed inward from the shelf portion and wherein the base portion comprises an inner member (763) of generally tubular shape coupled to the inner portion of the casing, the inner member extending downward from the base portion and having an aperture disposed therein that cooperatively engages the protrusion of the platform portion in a manner that selectively couples the nasal pillow to the platform portion.

19. The patient interface of claim 11, wherein the platform portion comprises a generally tubular chimney portion (874) extending upward therefrom and terminating at a top opening (878), the chimney portion including a rib portion (876) adjacent the top opening, the rib portion cooperatively engaging an upper portion of the inner portion of the casing in a manner that selectively couples the nasal pillow to the platform portion.

20. A patient interface device (10) comprising:
- (a) a body portion (20) comprising:
 - (1) a pair of arms (24),
 - (2) a chin support (22), wherein a first end portion of each arm (24) in the pair of arms is coupled to an opposite end of the chin support, and wherein the chin support is adapted to be disposed under the mandible responsive to the patient interface device being donned by a user,
 - (3) at least one headgear attachment (50), and
 - (4) a circuit portion (30) operatively coupled to a second end portion of each arm in the pair of arms; and
 - (b) a patient interface portion (40) operatively coupled to the circuit portion, the patient interface portion (40) comprising:
 - (1) a cushion (42) having a base portion (44) and a platform portion (48), the base portion being structured to couple the cushion to the body portion of the patient interface device; and
 - (2) a replaceable nasal pillow (46) disposed on, and selectively coupled to the platform portion (48) of the cushion, a portion (65) of the nasal pillow being structured to sealingly engage a nare of a patient.

21. The patient interface device of claim 20, the nasal pillow comprises:
- a base portion (62) disposed on the platform portion of the cushion;
 - a casing (64) coupled to the base in a manner which defines a sealed cavity therein, the casing having an outer portion (65) structured to sealingly engage a nare of a patient and an inner portion (67); and
 - a fill material (66) disposed in the sealed cavity defined by the casing and the base.

22. The patient interface device of claim 21, wherein the platform portion of the cushion comprises a generally tubular chimney portion (74) that includes a reduced diameter portion (76), and wherein the inner portion of the casing comprises a thickened

portion (70) that cooperatively engages the reduced diameter portion of the tubular chimney portion in a manner that selectively couples the nasal pillow to the patient interface device.

23. The patient interface device of claim 22, wherein the outer portion of the casing comprises a hooked portion (169) that extends below, and generally hooks around a portion (173) of platform portion in a manner that selectively couples the nasal pillow to the cushion.

24. The patient interface device of claim 21, wherein the platform portion comprises a generally tubular chimney portion (274) and wherein the base portion comprises a vertical portion (263) adjacent the inner portion of the casing that engages as an interference fit the chimney portion in a manner that selectively couples the nasal pillow to the platform portion.

25. The patient interface device of claim 21, wherein the platform portion comprises a planar shelf portion (372) having an inward directed portion (373), and wherein the base portion comprises a downward facing hook portion (363) that engages the inward directed portion of the shelf portion in a manner that selectively couples the nasal pillow to the platform portion.

26. The patient interface device of claim 21, wherein the platform portion comprises a generally tubular chimney portion (474) having a rib portion (476) and wherein the inner portion of the casing comprises a grooved portion (470) that cooperatively engages the rib portion (476) in a manner that selectively couples the nasal pillow (446) to the platform portion (448).

27. The patient interface device of claim 21, wherein the platform portion comprises a planar shelf portion (572) having an inward directed portion (573), and wherein the base portion comprises an inner member (563) of generally tubular shape

coupled to the inner portion of the casing, the inner member extending downward from the base portion and terminating in a hook portion (563A) that cooperatively engages the inward directed portion of the platform portion in a manner that selectively couples the nasal pillow to the platform portion.

28. The patient interface device of claim 21, wherein the platform portion comprises a planar shelf portion (772) having a protrusion (773) directed inward from the shelf portion, and wherein the base portion comprises an inner member (763) of generally tubular shape coupled to the inner portion of the casing, the inner member extending downward from the base portion and having an aperture (775) disposed therein that cooperatively engages the protrusion of the platform portion in a manner that selectively couples the nasal pillow to the platform portion.

29. The patient interface device of claim 21, wherein the platform portion comprises a generally tubular chimney portion (874) extending upward therefrom and terminating at a top opening (878), the chimney portion including a rib portion (876) adjacent the top opening, the rib portion cooperatively engaging an upper portion of the inner portion of the casing in a manner that selectively couples the nasal pillow to the platform portion.

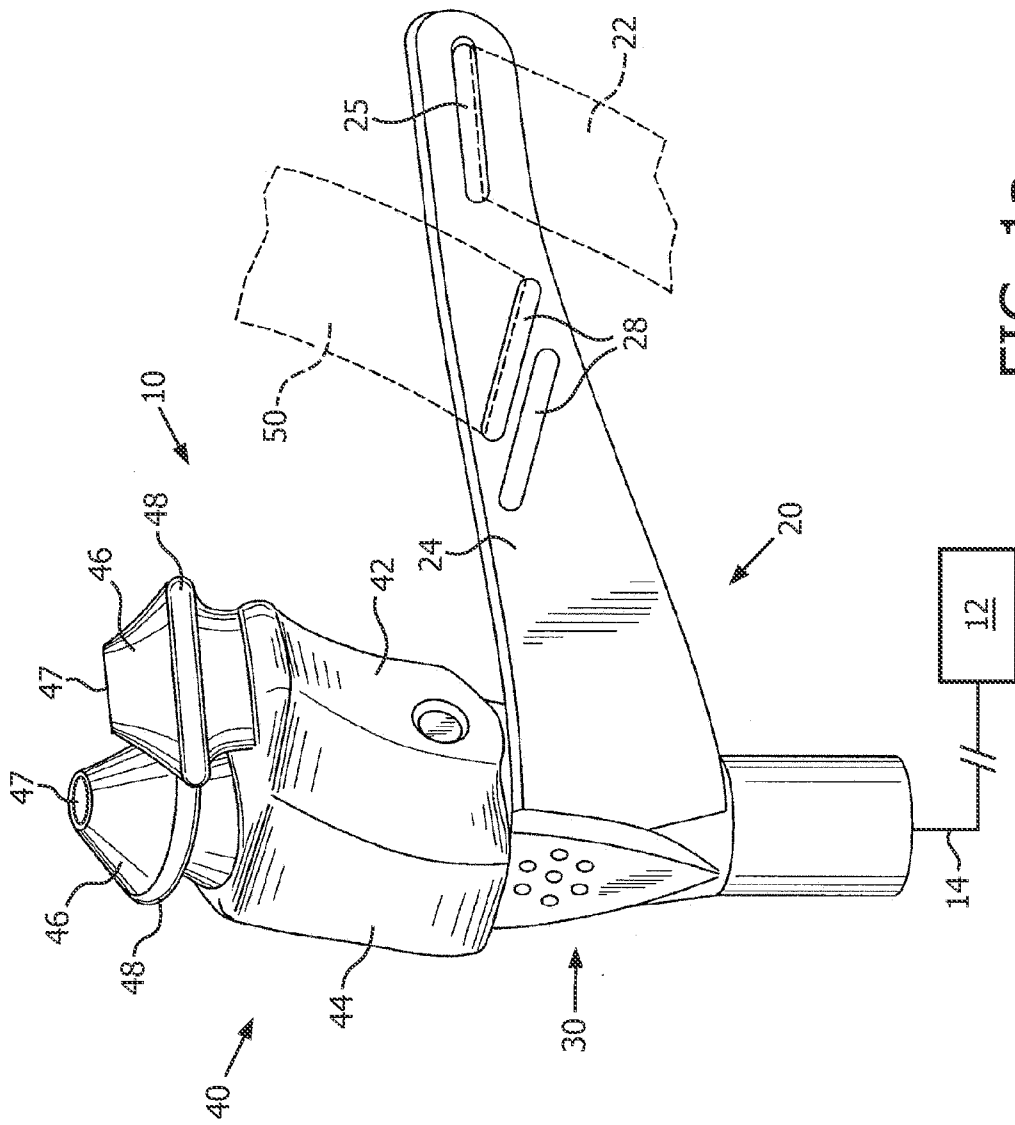

FIG. 1a

2/14

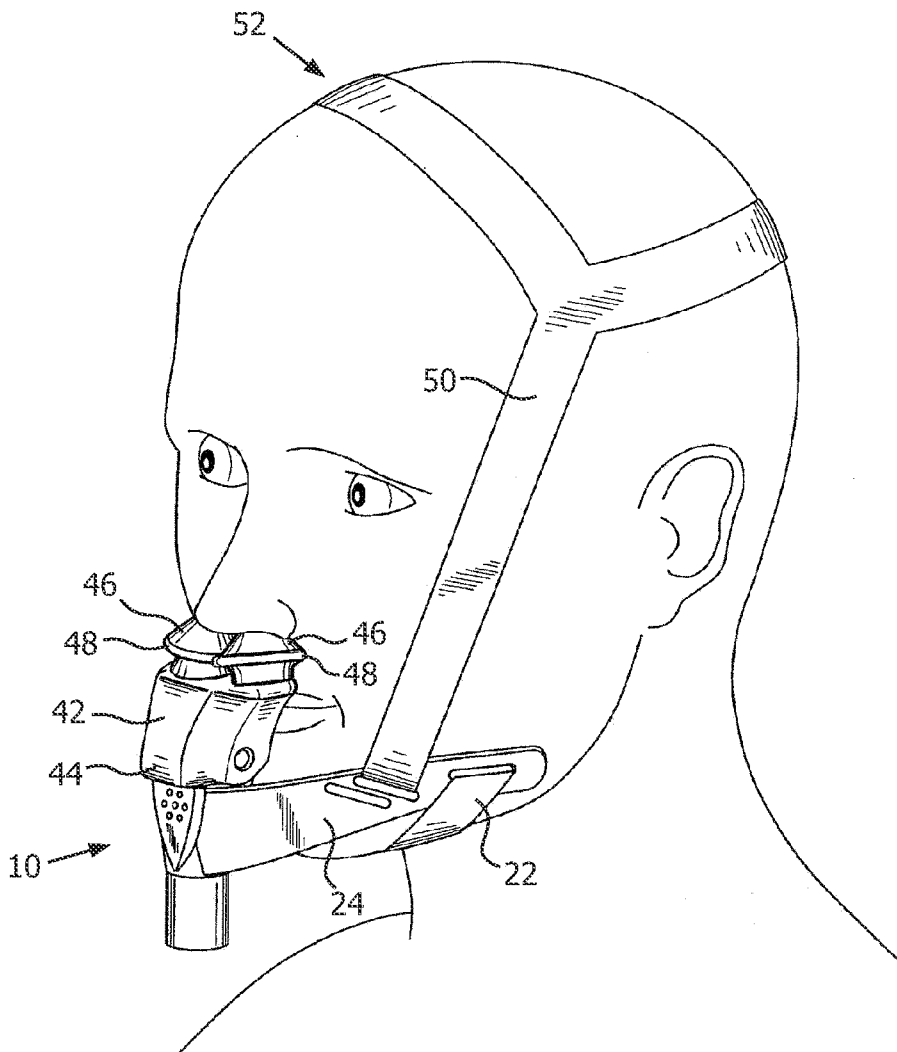

FIG. 1b

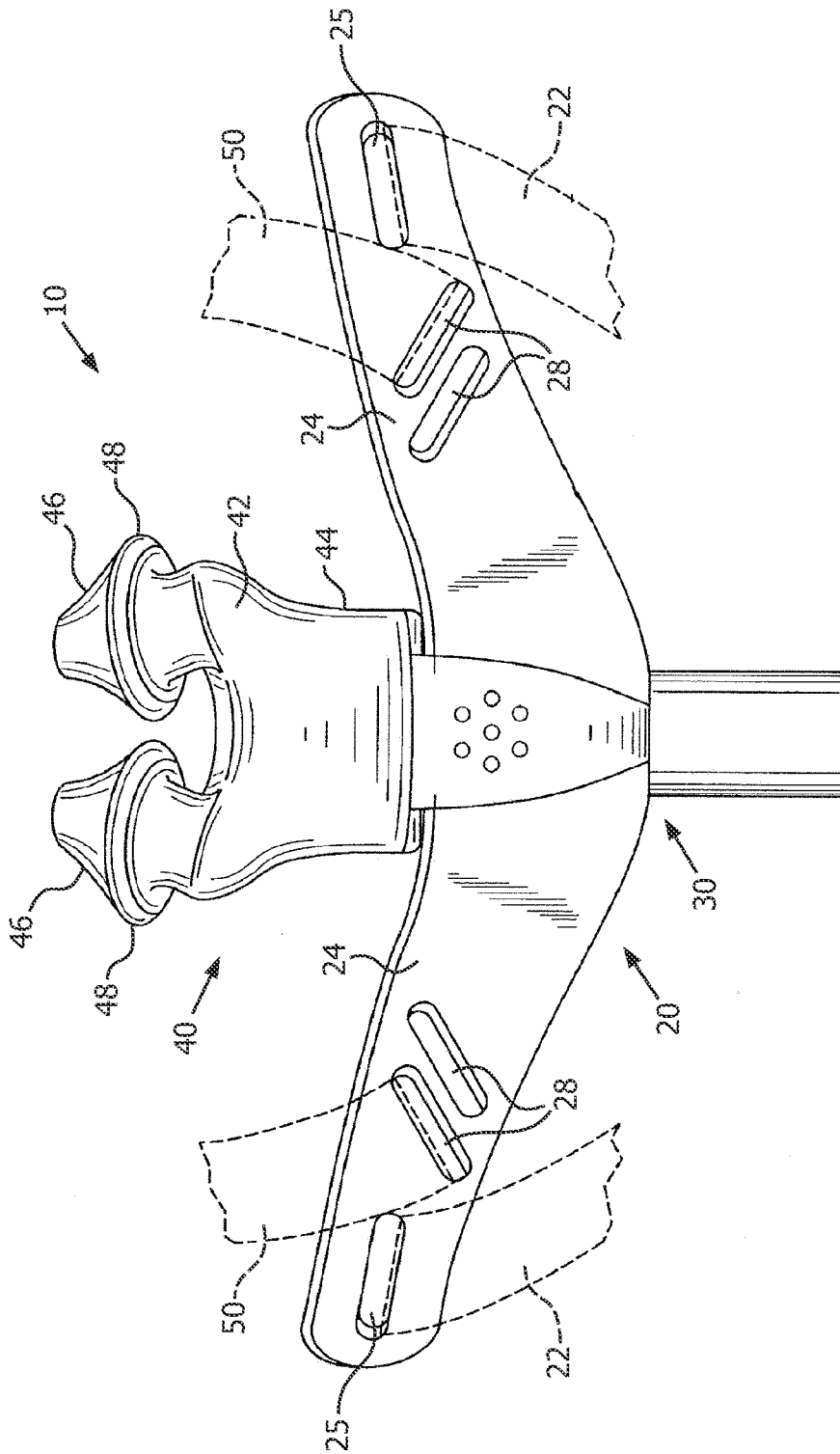

FIG. 2

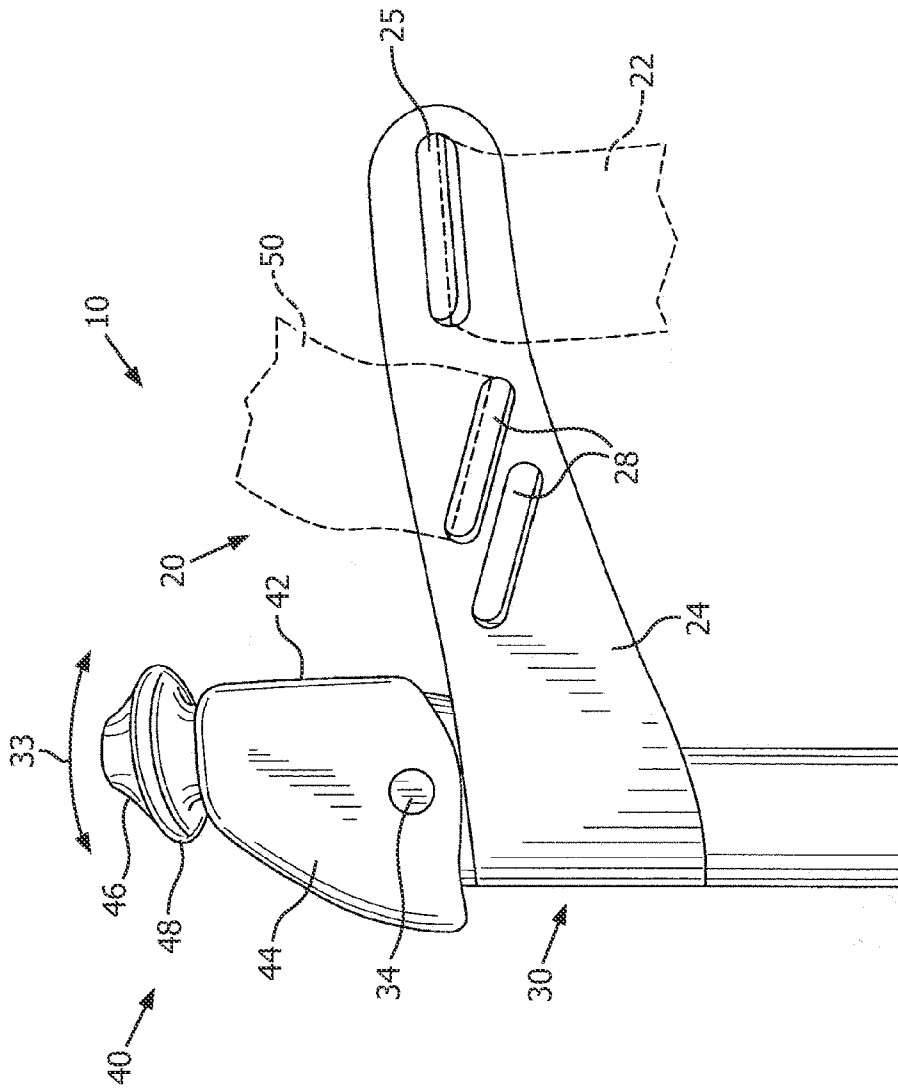

FIG. 3

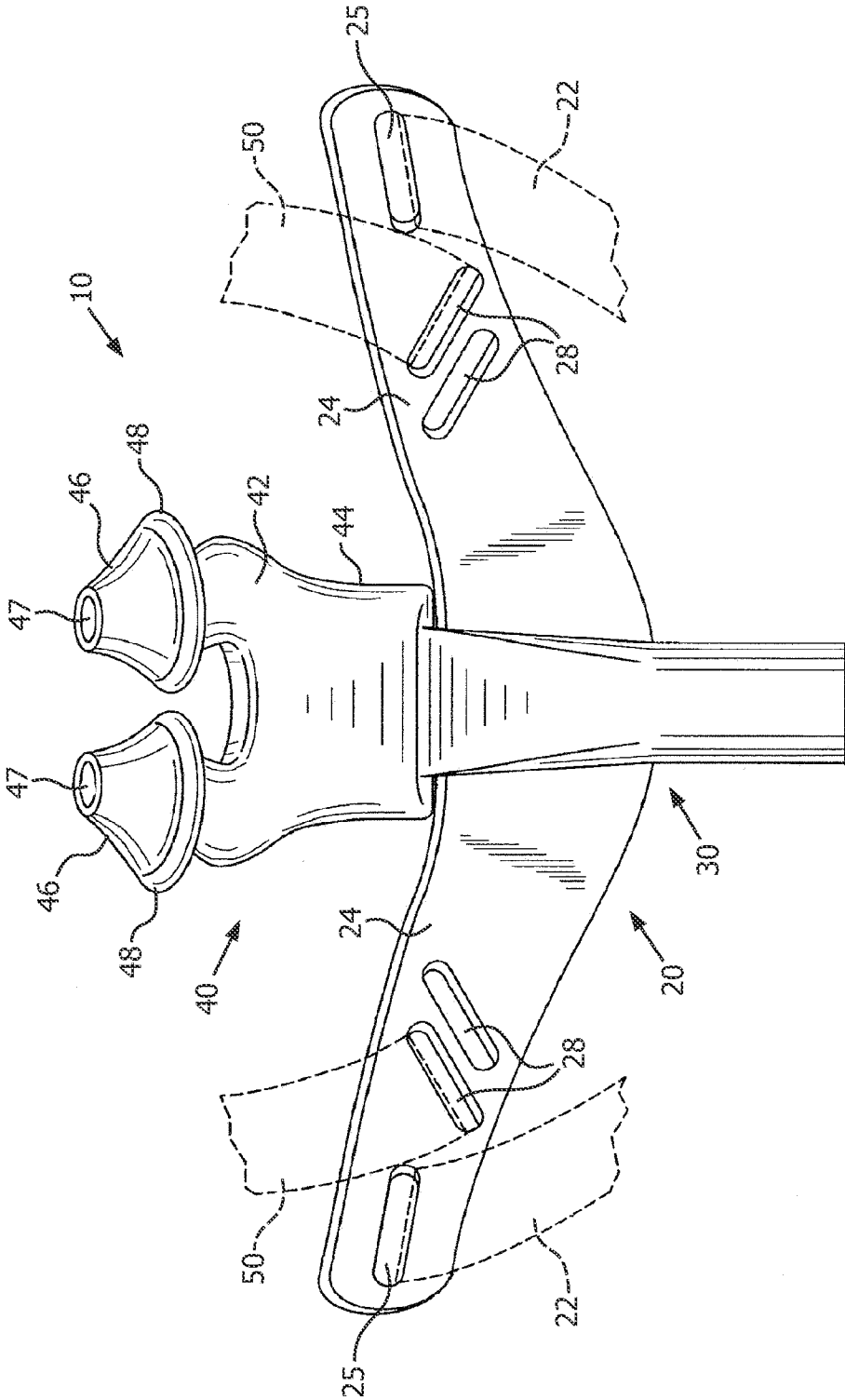

FIG. 4

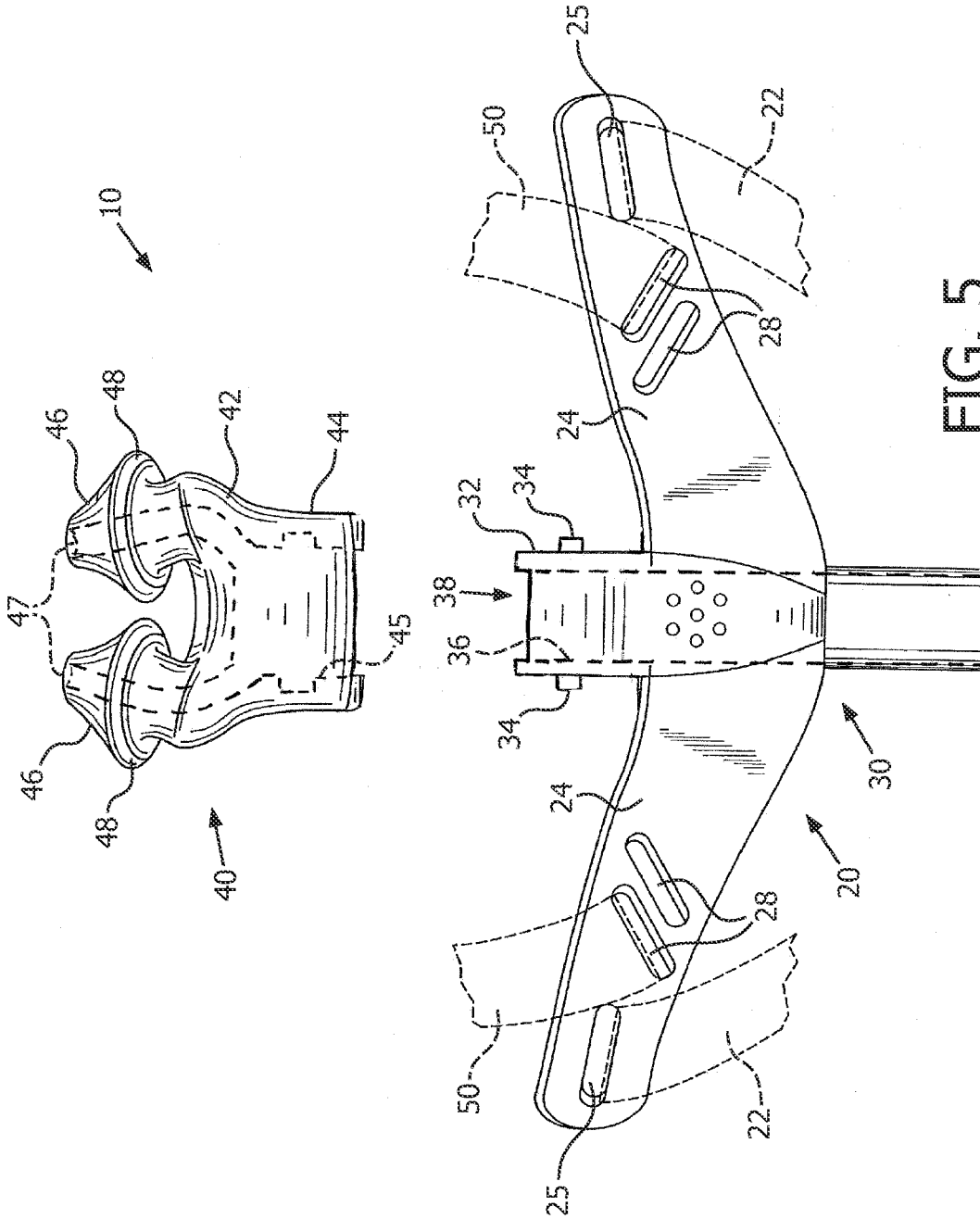

FIG. 5

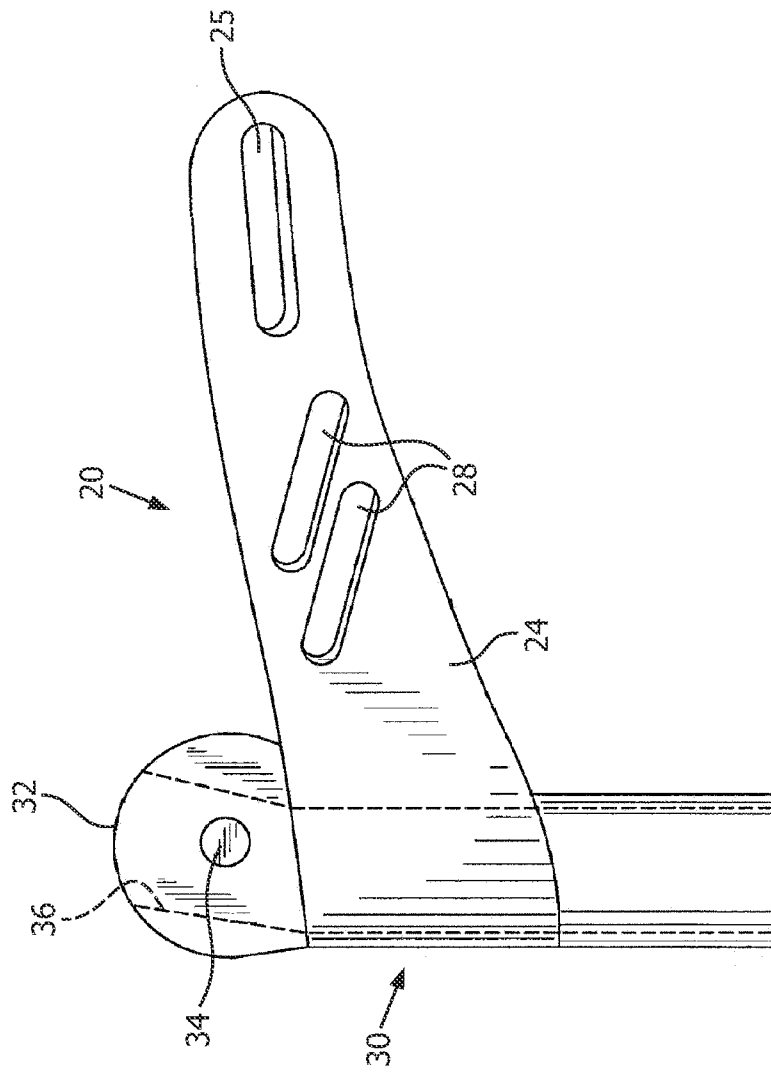

FIG. 6

8/14

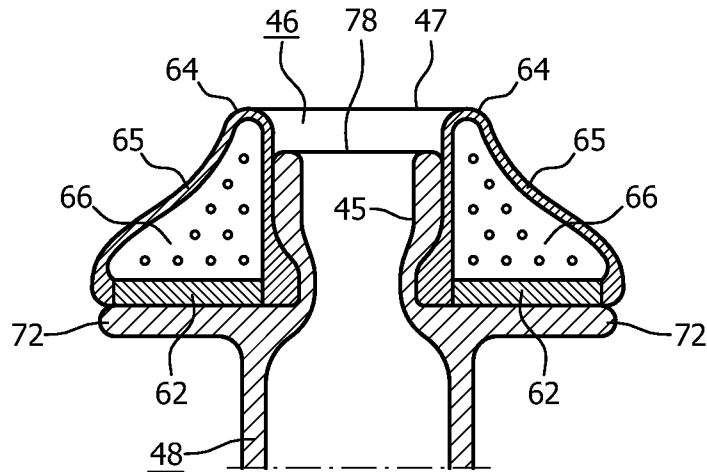

FIG. 7

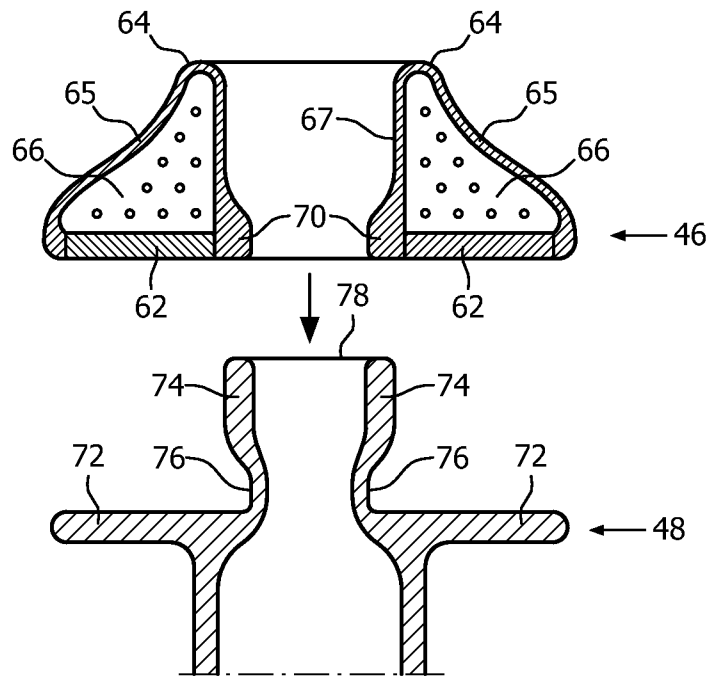

FIG. 8

9/14

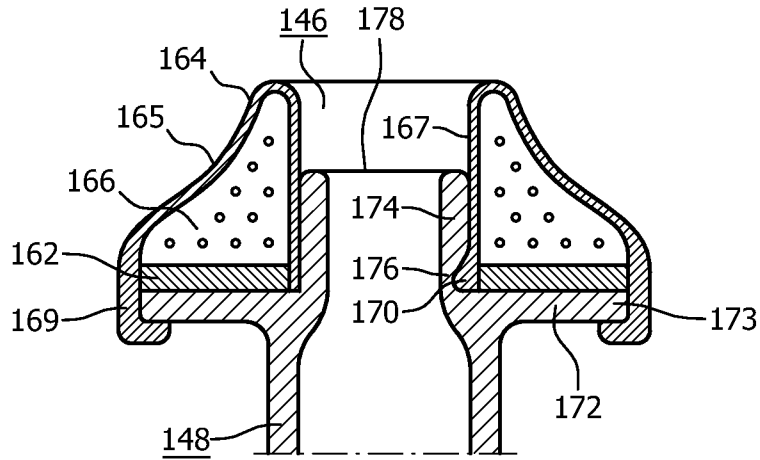

FIG. 9

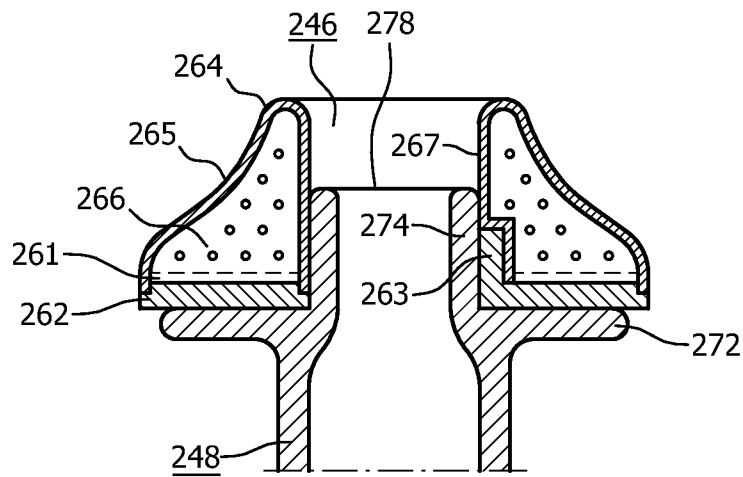

FIG. 10

10/14

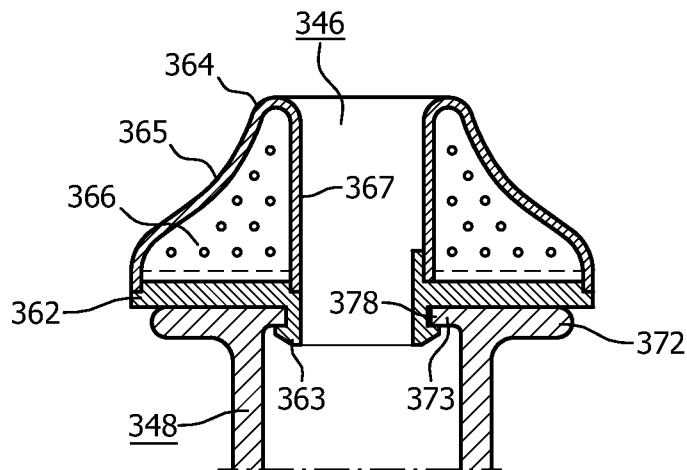

FIG. 11

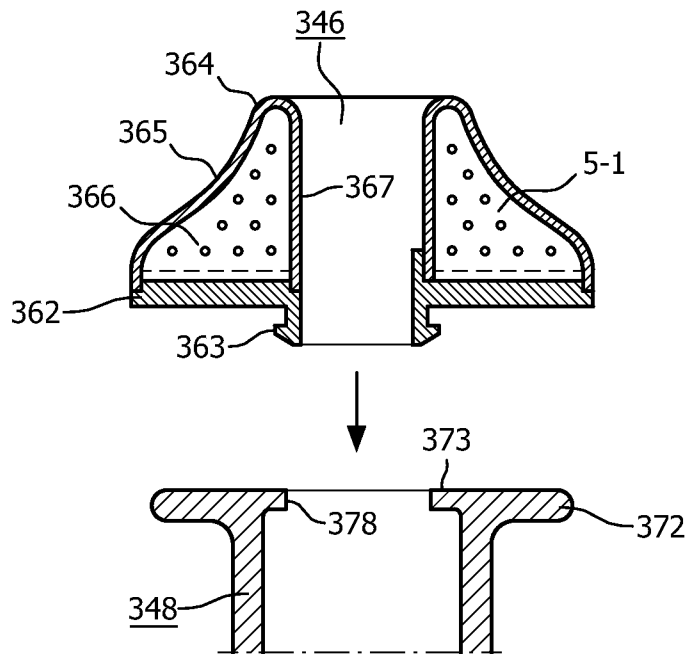

FIG. 12

11/14

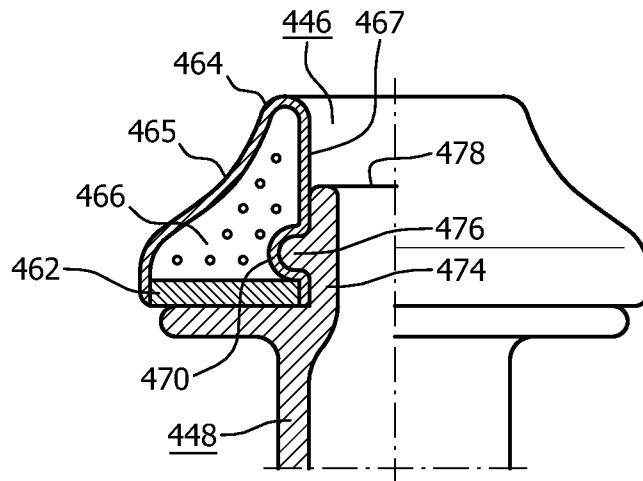

FIG. 13

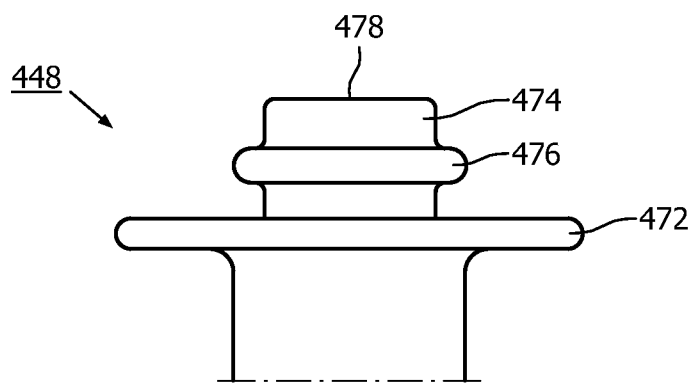

FIG. 14

12/14

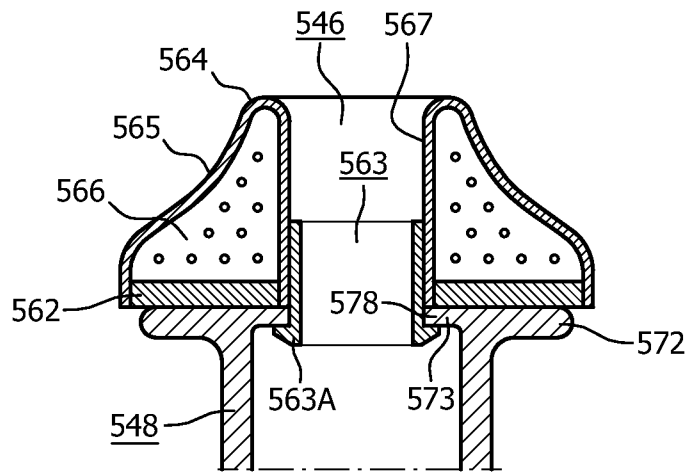

FIG. 15

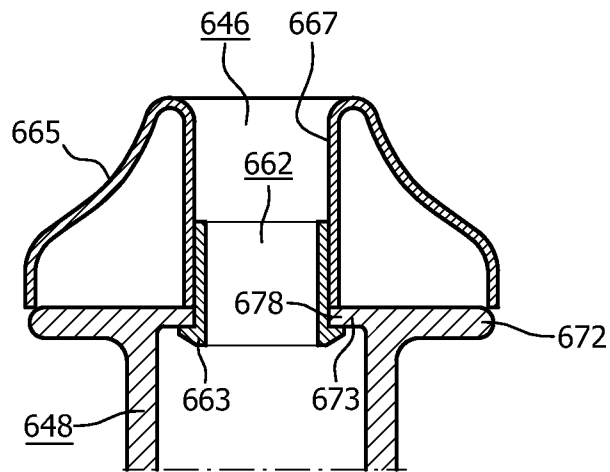

FIG. 16

13/14

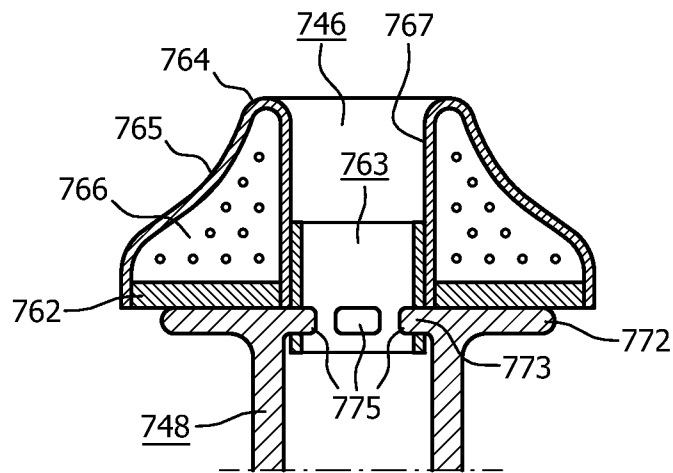

FIG. 17

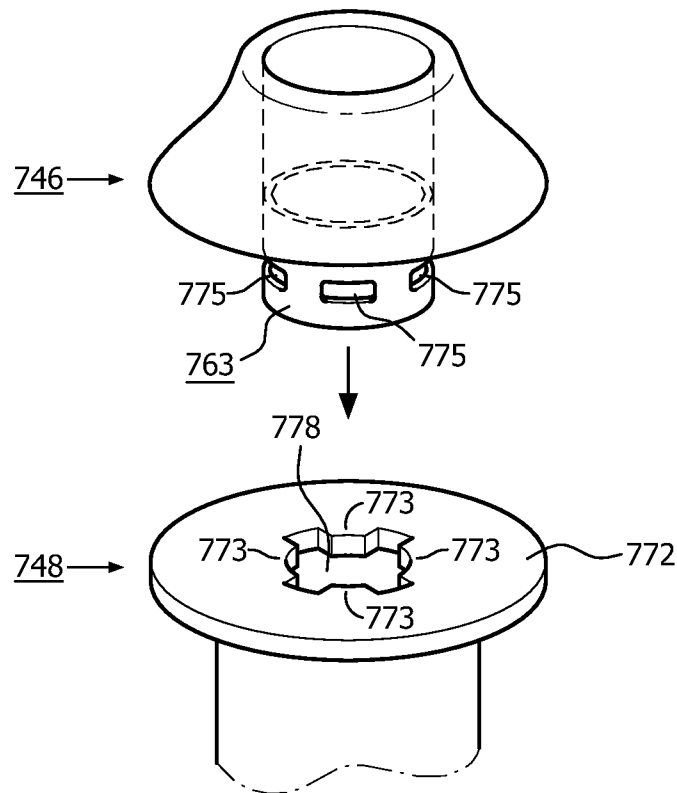

FIG. 18

14/14

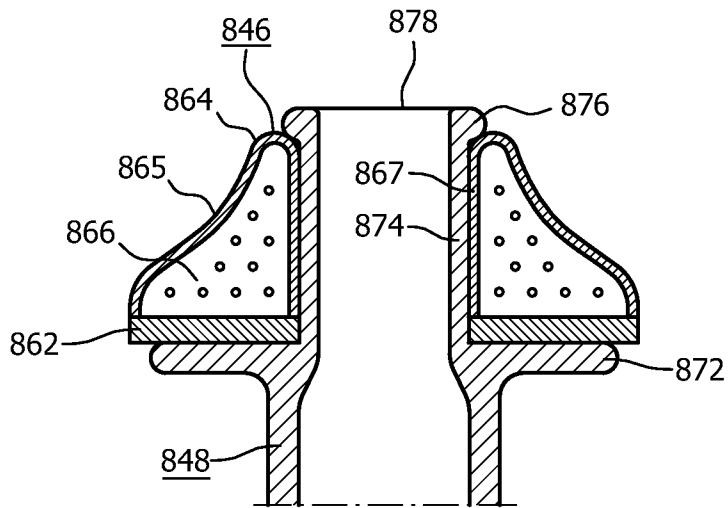

FIG. 19

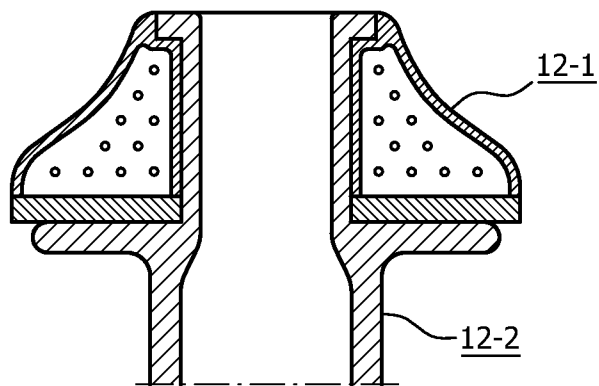

FIG. 20