

(19) World Intellectual Property
Organization
International Bureau



(43) International Publication Date
22 January 2004 (22.01.2004)

PCT

(10) International Publication Number
WO 2004/007255 A2

- (51) International Patent Classification⁷: **B60S 1/00**
- (21) International Application Number: PCT/GB2003/003061
- (22) International Filing Date: 16 July 2003 (16.07.2003)
- (25) Filing Language: English
- (26) Publication Language: English
- (30) Priority Data: 0216483.8 16 July 2002 (16.07.2002) GB
- (71) Applicant (for all designated States except US): **TRW LIMITED** [GB/GB]; Stratford Road, Solihull, West Midlands B90 4AX (GB).
- (72) Inventors; and
- (75) Inventors/Applicants (for US only): **HEENAN, Adam, John** [GB/GB]; 33 Nursery Road, Swallownest, Sheffield S26 4UH (GB). **HAZELDEN, Roger, John** [GB/GB];
- 27 Middlesmoor, Wilnecote, Tamworth, Staffordshire B77 4PL (GB). **THOMPSON, Martin, John** [GB/GB]; 1167 Yardley Wood Road, Birmingham B14 4LE (GB). **BUCHANAN, Alastair, James** [GB/GB]; 127 Welwyn-dale Road, Wylde Green, Sutton Coldfield, West Midlands B72 1AL (GB).
- (74) Agent: **BARKER Brettel**; 138 Hagley Road, Edgbaston, Birmingham B16 9PW (GB).
- (81) Designated States (national): AE, AG, AL, AM, AT, AU, AZ, BA, BB, BG, BR, BY, BZ, CA, CH, CN, CO, CR, CU, CZ, DE, DK, DM, DZ, EC, EE, ES, FI, GB, GD, GE, GH, GM, HR, HU, ID, IL, IN, IS, JP, KE, KG, KP, KR, KZ, LC, LK, LR, LS, LT, LU, LV, MA, MD, MG, MK, MN, MW, MX, MZ, NI, NO, NZ, OM, PG, PH, PL, PT, RO, RU, SC, SD, SE, SG, SK, SL, TJ, TM, TN, TR, TT, TZ, UA, UG, US, UZ, VC, VN, YU, ZA, ZM, ZW.
- (84) Designated States (regional): ARIPO patent (GH, GM, KE, LS, MW, MZ, SD, SL, SZ, TZ, UG, ZM, ZW), Eurasian patent (AM, AZ, BY, KG, KZ, MD, RU, TJ, TM), European patent (AT, BE, BG, CH, CY, CZ, DE, DK, EE, ES, FI, FR, GB, GR, HU, IE, IT, LU, MC, NL, PT, RO,

[Continued on next page]

(54) Title: RAIN DETECTION APPARATUS AND METHOD

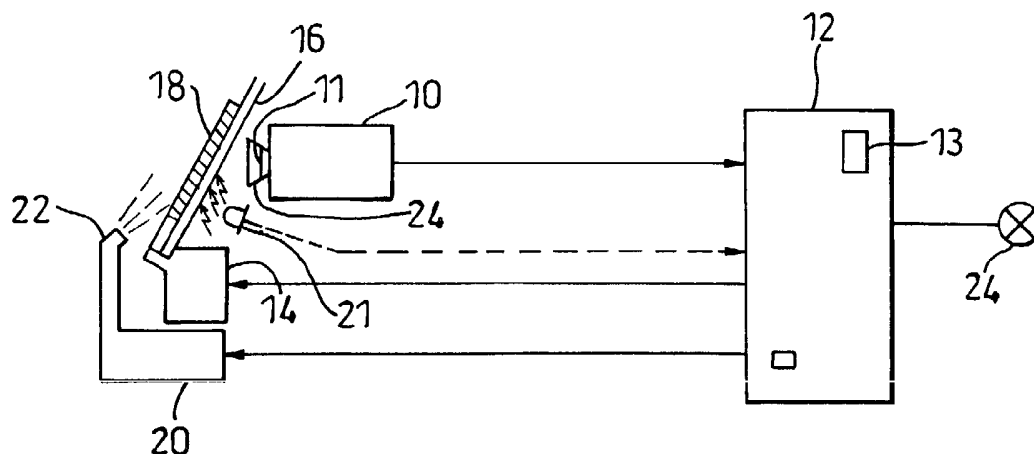

(57) Abstract: A rain detection apparatus and method, comprising a camera (10) adapted to view a surface (16) and a processor (12) adapted to capture at least one image from the camera (10), in which the processor (12) is further adapted to generate at least one signal indicative of the presence of rain on the surface from information contained in the at least one captured image and to, optionally drive surface cleaning apparatus in response thereto, in which the apparatus is adapted to capture images focussed at a plurality of distances; in which the processor includes edge detection means adapted to detect edges visible in the at least one captured image and difference means adapted to calculate the difference between the number of edges visible between differing images; and in which the edge detection means is further adapted to disregard edges close to areas of light larger than the largest raindrop that is desired or expected to be detected. The apparatus and method optionally includes a backlight (21), with the difference in numbers of edges between frames with and without the backlight (21) illuminated being used to distinguish between background features and rain on the surface. The surface (16) may be a vehicle windscreen, windshield or the cover or lens of a vehicle lamp, in which case the cleaning apparatus may be one or more wipers (18) or washers (22).

WO 2004/007255 A2



SE, SI, SK, TR), OAPI patent (BF, BJ, CF, CG, CI, CM, GA, GN, GQ, GW, ML, MR, NE, SN, TD, TG).

For two-letter codes and other abbreviations, refer to the "Guidance Notes on Codes and Abbreviations" appearing at the beginning of each regular issue of the PCT Gazette.

Published:

— *without international search report and to be republished upon receipt of that report*

RAIN DETECTION APPARATUS AND METHOD

This invention relates to rain detection apparatus and method. In particular but not exclusively, it relates to a vehicle window cleaning
5 apparatus. It also relates to a vehicle fitted with such an apparatus.

In one known situation, it has long been desired to automatically sense the condition of a vehicle window in order to activate vehicle window cleaning apparatus. An example would be to automatically activate the
10 wipers and/or washers of a car's window (commonly referred to as a windscreen or windshield) should the window become rained upon or should it become otherwise obscured by dust, dirt or debris.

Prior art solutions to the problem have generally used infra red sensors or
15 sensors of the visible yellow type mounted on the appropriate window. However, these only sense the condition of a limited area of window and require close association with the window, which can cause problems should the window need replacing.

20 As well as cleaning of vehicle windows, it is also desirable to provide for the automatic cleaning of many other surfaces where obscuring media such as rain drops, dirt or debris on the surface would cause problems if it obscures the view through the surface. An example would be the glass or plastic lens of a headlamp or other light of a vehicle.

25 According to a first aspect of the invention there is provided a rain detection apparatus, comprising a camera adapted to view a region of a surface and a processor adapted to capture at least one image from the camera, in which the processor is further adapted to generate at least one
30 signal to indicate the presence of rain on the surface from information contained in the at least one captured image.

By rain, we may include fog, mist, spray, drizzle and other forms of moisture or obscuring media that may form, fall or otherwise be incident upon the surface.

5

The apparatus may be adapted to capture images at a plurality of distances. In a particularly advantageous embodiment where the surface is a part of a vehicle, the apparatus may be adapted to sense the location of other vehicles or of lane markings on a road in which the vehicle to
10 which the system is fitted is situated. In such an embodiment, the camera may be adapted to be focussed at a plurality of distances. One of these distances may correspond to viewing the vehicle window and another to viewing the road ahead of the vehicle. Accordingly, the camera may be provided with a bi-focal lens, or a multi-focal lens. Alternatively, the
15 camera may, in use, continually change focus, or a focussing mirror may be used or other means of achieving a dual focus system may be provided. The camera may be adapted to focus on the surface over a first region of its field of view, and the road over a second region of its field of view.

20

Combining lane and vehicle detection apparatus with the apparatus herein described is especially advantageous as both use the same hardware and even elements of the same software and so use of such can be shared.

25 The surface may comprise a window, a window of a vehicle or perhaps a surface of a lamp such as a vehicle headlight. Such a system has the advantages that it requires no contact with the surface, it can work with visible light and can easily be adapted to sense any area of the window desired. In fact, it is preferable for the camera not to be in contact with
30 the surface.

The surface may be the front window of the vehicle, commonly known as the windscreen or windshield of the vehicle. Equally, it may be the rear window or any other window.

- 5 The apparatus may be adapted to control a vehicle window cleaning apparatus adapted to clean the surface, which may comprise one or more wipers, which wipe the surface of the vehicle window, preferably at an adjustable speed. The vehicle window cleaning apparatus may also comprise one or more washers, whereby washer fluid (perhaps water,
10 possibly with added detergent or anti-freeze) can be sprayed onto the surface of the vehicle window.

The surface may be a cover or lens of a vehicle light such as a headlight. In this case, a camera may be provided inside the headlight behind the
15 cover or lens.

The system may be provided with fault warning means such as a lamp or a sounder, which are adapted to alert a user of the system should a fault condition occur.

20

The processor may include edge detection means adapted to detect edges visible in the at least one captured image. This may be performed by calculating the spatial rate of change of pixel intensity in each of the at least one image. The spatial rate of change may only be calculated in
25 one, preferentially horizontal, direction. Accordingly, vertical edges would be thereby detected. This may be performed by convolving the image, typically with a Sobel-like mask or other suitable mask. The position of the edges may be determined as the positions at which the spatial rate of change exceeds a prescribed threshold. An example of a
30 suitable edge detection technique is taught in WO 99/44173 in which the edges of lanes on a highway are detected.

- The processor may also include counting means whereby the number of detected edges in the, or each, captured image may be counted. This may give an indication of the amount of rain on the vehicle window. In an alternative, the counting means may be adapted to count edges that are new compared with a previous image. Mask memory may be provided, which is adapted to record which edges are old, i.e. exist in the previous image, allowing the processor to determine which edges are new.
- 10 The apparatus may be provided with a backlight, arranged to illuminate the surface. The backlight may be adapted to cause any rain on the surface to be substantially more visible to the camera, for example by being mounted at an angle of less than 90° to the surface. The apparatus may be adapted such that rain is not visible to the camera without the backlight illuminated. This therefore allows successive images to be captured with and without the backlight illuminated. The backlight may comprise a plurality of individual illumination sources, or a single illumination source.
- 20 The processor may further comprise difference means adapted to calculate the difference between the number of edges visible between images captured with and without the backlight illuminated. This advantageously provides for the apparatus to be able to discern between background features such as the headlights of oncoming vehicles visible with or without the backlight illuminated and rain and suchlike only visible (or only detectable) with the backlight illuminated. Furthermore, only counting the number of edges in each image and then taking a difference requires the use of less memory than a frame subtraction technique, where individual elements (such as pixels or individual edges) of differing captured images are compared. It is also less prone to errors due the background of the images captured changing, as the position of the edges
- 25
30

counted is irrelevant. The difference means may also subtract the number of edges due to specular reflection of the backlight from the number of edges detected. This may be a predetermined constant number.

- 5 The backlight may be adapted to illuminate the surface with visible or infrared light, and may illuminate the surface with a given range of frequencies. The processor may be adapted to control the activation of the backlight. The apparatus may further comprise a filter, typically an optical bandpass filter, which preferentially allows the range of
10 frequencies to pass.

In an alternative to the masks discussed above, the mask with which the, or each, captured is convolved may be adapted to disregard edges close to areas of light larger than the largest raindrop that is desired or expected
15 to be detected. The mask may therefore ignore edges due to the headlights of oncoming vehicles or specular reflection off the surface. The mask may comprise a central peak, and two troughs spaced on either side of the central peak in convolution space. The peaks and the troughs may be of non-zero width, and may be separated from one another by
20 areas of mask having a value of zero, or substantially zero. The peaks and the troughs may be of opposite sign, and may each have linear rising and falling edges and an optional constant maximum absolute value of non-zero width in convolution space.

- 25 Use of this mask may mean that the results of convolving the, or each, captured image with the mask for an edge corresponding to a background feature such as an oncoming headlight or the specular reflection of the backlight off the surface are less significant than those for edges due to rain. The apparatus may therefore include thresholding means whereby
30 any detected edges having a convolved value less than a predetermined threshold are not considered as edges.

The apparatus may be further adapted to detect the presence of mist on the surface. By mist, we may mean mist, fog or other small radius drops of moisture. To this end, the processor may be adapted to calculate the
5 difference in intensity of the captured image in the area around, but not including, the area of the image in which the specular reflection of the backlight is found, between images in which the backlight is illuminated and where it is not. The presence of a high difference in illumination has been determined to be indicative of the presence of mist (large amounts of
10 non-specular reflection). The difference may be taken of the average intensities around the specular reflection of the backlight, or the difference itself may be averaged.

According to a second aspect of the invention there is provided a vehicle
15 fitted with the surface cleaning apparatus control system of the first aspect.

According to a third aspect of the invention, there is provided a method
20 of detecting the presence of obscuring material on a surface, the method comprising capturing images of the surface and then calculating one or more characteristics of the condition of the surface from the captured images.

The surface may comprise a vehicle window, or perhaps a cover for a
25 light of a vehicle such as a headlamp. The images captured may be specifically focussed on the vehicle window.

In a particularly advantageous embodiment, the method also includes
30 detecting the positions of lanes or vehicles surrounding a vehicle from information contained in the at least one captured image. In such a case, the at least one captured image may be partially focussed on the vehicle

window and partially elsewhere, for example on the road ahead of the vehicle. Alternatively, successive captured images may be focussed on the vehicle window for use in determining the condition of the vehicle window and elsewhere, for use in lane and vehicle detection.

5

The images may be captured at a rate of substantially 100, 50, 20, 10, 5, 2 or 1 per second, or every 1s, 2s, 5s or 10s. Equally, they may be captured at any suitable rate. The images may be captured at a fixed rate substantially between 1 to 100 per second or one image between for example 1 to 10 seconds. Optionally the capture rate may be varied in accordance with a prescribed operational parameter of the system such as vehicle speed when the invention is associated with a motor vehicle.

10

The images may be of substantially all or part of the surface to be sensed such as between 1% and 100% of the total surface. For example, they may be of at least 75%, 50%, 40%, 30%, 25% or 10%. The size may be determined so as to provide sufficient data for reliable processing.

15

The method may include the step of detecting edges visible in the images. This may include the step of calculating the spatial rate of change of pixel intensity in each of the images. The spatial rate of change may only be calculated in one, preferentially horizontal, direction. Accordingly, vertical edges would be thereby detected. This may be performed by convolving the image, typically with a Sobel-like mask. The position of the edges may be taken as the positions at which the spatial rate of change exceeds a predetermined threshold.

20

25

Alternatively, the mask may be adapted to disregard edges close to areas of light larger than the largest raindrop that is desired or expected to be detected. The mask may therefore ignore edges due to the headlights of oncoming vehicles or specular reflection off the surface. The mask may

30

comprise a central peak, and two troughs spaced in convolution space therefrom. The peaks and the troughs may be of non-zero width, and may be separated from one another by areas of mask having a value of zero, or substantially zero. The peaks and the troughs may be of opposite
5 sign, and may each have linear rising and falling edges and an optional constant maximum absolute value of non-zero width in convolution space.

Use of this mask may mean that the results of convolving the, or each, captured image with the mask for an edge corresponding to a background
10 feature such as an oncoming headlight or the specular reflection of a backlight off the surface are less significant than those for edges due to rain. The method may therefore include the step of thresholding the convolved values such that edges having a convolved value less than a predetermined threshold are not considered as edges.

15 The edges detected may be those of raindrops. By raindrops, we may include fog, mist, spray, drizzle and other forms of moisture or obscuring media that may form, fall or otherwise be incident upon the surface.

20 The number of detected edges in each image may then be counted to give, for example, an indication of the amount of rain on the vehicle window. This may be referred to as an "edge counting" method. In an alternative, so-called "edge boundary masking" method, edges that are new compared
25 with a previous image may be counted. In the case where there is no previous image, all detected edges may be counted as new. Preferably a running total of new edges is kept. A mask may be used to record which edges are new. With each image, the mask may be updated. Updating the mask may involve marking the areas around new edges as old. The
30 area marked as old with each new image may be the new edges dilated by a predetermined amount.

These two alternatives provide two different ways to interpret the edges visible on the vehicle window. The first alternative is simple and requires little processing power whilst the second alternative is more able
5 to cope with shifting raindrops and movement of background images. Furthermore, in the second alternative the number of new edges in each image may be used to determine the rate at which it is raining and the running total may be used to determine the amount of rain on the vehicle window.

10

The method may further comprise the step of taking the difference between the number of edges visible between images captured with and without a backlight illuminated. This advantageously provides for the method to be able to discern between background features such as the
15 headlights of oncoming vehicles visible with or without the backlight illuminated and rain and suchlike only visible (or only detectable) with the backlight illuminated. Furthermore, only counting the number of edges in each image and then taking a difference requires the use of less memory than a frame subtraction technique, where individual elements
20 (such as pixels or individual edges) of differing captured images are compared. It is also less prone to errors due the background of the images captured changing, as the position of the edges counted is irrelevant. The difference means may also subtract the number of edges due to specular reflection of the backlight on the surface from the number
25 of edges detected. The number of edges due to specular reflection of the backlight on the surface may be a predetermined constant number.

The method may further include the step of controlling vehicle window cleaning apparatus according to the sensed vehicle window condition.
30 Advantageously, the vehicle window cleaning apparatus may include one

or more wipers, which wipe the vehicle window, or washers, which spray the vehicle window with fluid.

In a further development of the system, the average size and or density of the detected media may be further used to control the cleaning apparatus. In the case that the vehicle window cleaning apparatus is one or more wipers, such control may include calculating average raindrop size and density. The average size and density of raindrop may then be used to generate a signal indicative of the speed at which the wiper or wipers are to run. An intermediate factor may be calculated for each of the density and average raindrop size. These two factors may then be multiplied together to form a wiper control signal. Each factor may be between 0 and 1. Each factor may be zero below a first value of either average raindrop size or density respectively and 1 above a second value of average raindrop size or density respectively. Between first and second values, the factors may linearly increase with average raindrop size or density. The factors may increase from an initial factor value to a terminal factor value. Preferably, the initial factor value is between 0 and 1 and the terminal factor value is 1.

Accordingly, the wiper or wipers will only be operated should both average size and density of raindrops exceed certain limits, and will be limited to running at a maximum speed indicated by a wipe control signal of "1".

The limits at which wipers (or other cleaning apparatus) are operated may be adjustable, and may be controlled by a user such as a driver of a vehicle. This can also be applied with the basic edge detection method, with the number of edges that need to be obscured before cleaning being adjustable or otherwise user defined.

The vehicle window cleaning apparatus may be activated with no direct user interaction. This enables the user of a vehicle to concentrate on their driving or other such tasks without the need to directly operate the apparatus.

5

In the case where the amount of rain is determined by counting new edges, at least one of any running total and the mask may be reset when the vehicle window is cleared. This may be sensed by determining when the wiper or wipers have wiped the vehicle window. Alternatively, the total number of edges visible ignoring the mask may be counted and should a sudden decrease occur the vehicle window is considered cleared.

10

This step is included as the edge boundary masking method assumes that edges never disappear and hence the total number of edges always increases.

15

The amount of rain may be integrated over time, such that the amount of time that rain has been present on the surface is taken into account. The method may include the step of causing the surface to be cleaned when the integrated value exceeds a predetermined limit. This advantageously allows small amounts of rain to be wiped after a maximum amount of time.

20

Furthermore, the method may include determining whether at least one of dirt, dust, ice, frost and mist exist on the vehicle window. If one or more does, then appropriate steps such as activating the vehicle window cleaning apparatus, activating a vehicle window heater, activating a vehicle heater or activating a vehicle air conditioning system may be taken. The method may include reading the temperature external to the vehicle, typically with an onboard external temperature sensor of the vehicle. The method may therefore include activating the vehicle heater

25
30

or demister in response to the measured temperature, preferably in combination with the detected window condition.

By mist, we may include haze, dew, fog or other small radius drops of moisture. To this end, the method may include the steps of calculating the difference in intensity of the captured image between images in which a backlight is illuminated and where it is not in the area around, but not including, the area of the image in which the specular reflection of the backlight is found. The presence of a high difference in illumination has been determined to be indicative of the presence of mist (large amounts of non-specular reflection). The difference may be taken of the average intensities around the specular reflection of the backlight, or the difference itself may be averaged.

Also, the method may include the step of detecting from the smear pattern visible on the vehicle window after a wipe has passed the condition of the wiper. This may involve a Hough transform of the smear pattern. Such smear patterns may also be used to indicate dirty water on the vehicle window and to take appropriate action. The system may be able to differentiate between rain, snow and ice.

The invention will now be described by way of example with reference to the accompanying drawings, in which:

Figure 1 shows schematically a sensing system according to the present invention;

Figure 2 shows an image captured by a video camera;

Figure 3 is a flow chart depicting a first method of estimating the amount of rain on a windscreen;

Figure 4 is a flow chart depicting a second method of estimating the amount of rain on a windscreen.

5 **Figure 5** is a graph showing the relationship between average raindrop size or density and the intermediate, scaled, value;

Figure 6 shows the steps taken in calculating the wiper demand signal from the edge count out part;

10

Figure 7 shows a mask for use in convolving the captured images;

Figures 8a, 8b and 8c show the effect of the presence of mist on the windscreen;

15

Figure 9 shows a Frame Subtraction technique according to the prior art;

20

Figure 10 shows an Edge Subtraction technique according to the present invention;

Figure 11 shows the steps carried out in this method in common with a lane detection technique;

25

Figure 12 shows the steps carried out in order to detect the presence of mist on the windscreen; and

Figure 13 shows a wiper control strategy.

30 **Figure 1** shows a sensing system according to the present invention. The system comprises a camera 10, which views the scene visible through a

windscreen 16 of a car. The camera is connected to a processor 12, which is adapted to capture images from the camera 10. Also provided are wipers 18 (only one of which is shown in Figure 1) which are, as is common in the art, in the forms of arms, which can be driven in an arcuate path over the outer surface of windscreen 16 by wiper motor 14. Wiper motor 14 is responsive to signals generated by processor 12. Further provided is washer pump 20, which is optionally adapted to respond to signals generated by processor 12 to pump washer fluid (usually water, perhaps with detergent or anti-freeze additives) onto windscreen 16 through nozzles 22 at an appropriate safe time. The system is also provided with a fault warning light 24, which indicates the presence of a fault condition.

The signals which are generated by the processor 12 in order to control the actuation of wiper motor 14 and optionally the washer pump 20 are calculated at least partly in response to the images captured from the camera 10. These shall now be described hereinbelow for a more specific embodiment of the invention, which uses an edge detection algorithm to determine the amount of rain on the windscreen.

This embodiment also uses the apparatus described above. Camera 10 is mounted inside the body of a car on a mounting bracket (not shown) attached to the roof of the car. The camera views the scene in front of the car through the windscreen. The system, in addition to sensing rain on the windscreen, is adapted to sense the position of other vehicles and lane markings etc. In order to facilitate this, a bifocal lens 24 is fitted to camera 10. The images captured from the camera 10 are therefore split horizontally as exemplified in Figure 2.

An optional light source, such as IR/LED 21 aimed at back-lighting the windscreen may be provided. This may be enabled when detected or

otherwise determined ambient light levels fall below a prescribed level. The effect or the use of the LED would be to highlight the edges of the obscuring media present on the image scene so as to enable the control system to perform more reliably. An optical bandpass filter 11 is also
5 provided, which increases the dominance of the backlight wavelength against the background scene.

Figure 2 shows an example image 30 captured by the camera 10. The image 30 is split into a top part 32 and a bottom part 34, divided by a
10 dividing line 42. This line 42 is not normally visible in the image but has been depicted for purposes of clarity. The top part 32 has been focussed on the outer surface of windscreen 16 on which raindrops 36 are visible. In the bottom part 34 of the image, the image has been focussed on the road ahead whereby features such as road edges 38, lane markings 40 and
15 other vehicles 44 can be seen. The processor can then use any of the methods known in the prior art to calculate the position of these features. Unless specifically mentioned, when referring to the images we shall henceforth refer to the top part 32 of the captured images as the part relevant to the amount of rain on the windscreen.

20

In order to calculate the need to wipe the windscreen 16 the steps of a first method, shown in Figure 3, are taken. Firstly, at step 100, the processor 12 periodically captures the top part 32 of images viewed through the camera 12. This occurs N times a second, although it is
25 envisaged that it may be more or less frequent. By way of example only, N may be in the range 15 to 40 times a second.

The next step 102 is for the captured images to be convolved with a mask, such as a Sobel-like mask. The resultant values represent the
30 spatial rate of change, in the horizontal direction, of the pixel intensity of the image. Taking a threshold 104 of these values (that is, determining

the points in the image at which the convolved values exceed a pre-determined value) then gives an indication of where the vertical edges of raindrops 36 lie.

- 5 This method of edge detection is used as it is commonly in use in lane and vehicle detection systems, such as is known from WO 99/44173.

An alternative edge detection scheme replaces convolution with the Sobel-like mask with convolution with the mask 51 depicted in Figure 7 of the
10 accompanying drawings. This consists of a central peak with two outer troughs to either side (in convolution space). The peaks and troughs have linear leading and rising edges and may have areas of constant value between them or at their absolute maxima. Convolution with this mask
15 gives high values for edges, but edges that occur close to large areas of light are penalised. Accordingly, vehicle headlights and the specular reflection of the backlight 21 off the vehicle windscreen 16 are disregarded as not being raindrops. The width and position of the peaks (as in trace 51a of Figure 7 of the accompanying drawings) can be adjusted in order to tune the raindrop detection and headlight elimination
20 characteristics.

However, the person skilled in the art will recognise that any suitable edge detection algorithm could be used.

- 25 In the next step 106, the number of edges is counted. This gives an indication of the amount of rain present on the windscreen 16 particularly where day and/or night screens are being viewed and where the glare from oncoming headlights would need to be accounted for. Use of multiple mask types, enables independence upon the prevailing ambient
30 scene conditions to be complemented using a simple suitability logic.

In an improvement to this step shown in Figure 10 of the accompanying drawings, the backlight 21 may be employed to increase the visibility of the edges of raindrops. The backlight 21, camera 10 and edge detection method can be arranged such that edges of raindrops are only detected
5 when the backlight 21 is illuminated. Images are captured without 203 and with 207 the backlight 21 illuminated, and the number of edges in each of the images calculated. Images captured without the backlight illuminated will only show background details such as passing scenery and headlights of oncoming vehicles. Illuminated images will show the
10 same features, plus highlighted raindrops and the specular reflection of the backlight in the windscreen. The number of edges for non-illuminated images then is subtracted 209 from the number of edges for the illuminated images. This value can be used to control 211 the wipers of the vehicle in the manner described below.

15

Accordingly, such artefacts as headlights and passing scenery can be accounted for without the complications and memory requirements of comparing frames, as in the prior art method shown in Figure 9 of the accompanying drawings. The prior art method requires frames to be
20 captured without 202 and with 206 the backlight illuminated and the pixel values for each frame are subtracted from one another. Edges are detected 210 in the resultant image and wiper control 212 carried out from the determined number of edges. This requires much more memory and processor time than the method of Figure 10 of the accompanying
25 drawings, as entire frames are compared rather than single numbers of edges.

If the specular reflection of the backlight has not been removed from the detected edges by the alternative mask 51, then these reflections can be
30 accounted for by subtracting a further, predetermined amount from the number of edges for the illuminated images.

In an alternative embodiment, the first method of determining the amount of rain on the windscreen is replaced by a second method depicted in Figure 4. Steps equivalent to those in the first method have been
5 indicated by the same numeral increased by 50.

In this method, the images are periodically captured 150, convolved and thresholded 154 as in the first method. The resultant edges are then compared 160 to a mask 170 stored in a memory 13 associated with the
10 processor 12. The mask 170 indicates which part of the scene is already considered to be an edge of a raindrop, and so initially the mask 170 will be blank. The comparison hence shows the raindrops which have formed edges since the mask 170 was last updated. The number of these new edges is counted 162 and added 164 to a running total 172. This total 172
15 will initially be zero.

The mask is then updated 166 by dilating the new edges by a dilation amount of, say, 5 pixels and marking the dilated edges on the mask 170 as having been seen. This is a reasonable compromise between mistaking
20 old edges that have simply moved slightly with respect to the camera 10 as new edges and mistakenly ignoring new edges that form. Of course, this dilation amount can be varied to achieve the best results.

The method then repeats with the next image captured 150 from the
25 camera using the updated mask 170 and total 172. It can be seen that the total will never decrease merely from adding the number of new edges. Accordingly, it is necessary to reset the total 172 and mask 170 when a signal from the wipers 18 indicates the screen is freshly wiped. Alternatively, the first method may be employed to give a reading of total
30 number of edges visible and the total 172 and mask 170 could be reset if a

large, sudden, decrease in the total number of edges according to the first method was seen.

To estimate the amount of rain on the windscreen, it is possible to use the total number of edges from either method. Additionally the number of new edges in each image as calculated by the second method can be used as an indication of the rate of fall of rain. When a prescribed or adapted threshold number of edges is reached, an enabling control signal 174 may be generated causing the wash/wipe cleaning apparatus to be activated to sweep and clean the windscreen.

In a preferred alternative depicted in Figure 13 of the accompanying drawings, the number of edges is integrated over times such that small amounts of rain are cleaned off the windscreen after a maximum period. The number of edges for a given frame is counted according to any of the methods described above. If this value is greater than a predetermined "noise" threshold, then the number of edges is added to a running total. If not, the running total is reset to zero. If the running total exceeds a predetermined "wipe" threshold, the wipers are activated and the running total reset. Otherwise, the running total is kept for the next captured image. The method then repeats.

In a further optional refinement, the processor may then use these aforementioned outputs to calculate average size and density of raindrops on the windscreen, as shown in Figure 6. These are then each scaled to give a value between 0 and 1 according to Figure 5. Below a certain range of raindrop size or density the scaled value is constantly zero; above the range the scaled value is constantly 1; and within the range the scaled value increases linearly with raindrop size or density from a minimum

scaled value 201 (which is between 0 and 1) to 1. These two scaled values are multiplied together 218 to give a wiper demand signal 220 between 0 and 1. This signal 220 indicates the fraction of maximum wiper speed at which the wipers 18 should run, where 0 is no wiper action and 1 indicates maximum speed, providing for the wipers 18 only operating above a certain threshold of both size 210 and density 212 of raindrops.

The method used in this system is advantageously combined with a vehicle lane and object detection system as the steps of capturing 100, 150 and convolving 102, 152 images (grouped as 108 and 158 in Figures 3 and 4) are already performed by such a detection system and hence the addition of a rain drop detection system as described herein does not unduly increase computational requirements. As to the choice between first and second methods, the first method requires less computational power and memory. However, it will produce much noisier results as raindrops shift with vehicle vibrations and so on, and as the unfocused scene behind the windscreen changes. As the second method uses an Edge Boundary Masking algorithm, it is less affected by these problems but requires more in the way of memory and processor use.

It is also appreciated that whilst with the cameras which are envisaged to be used in this system will not clearly capture the image of a passing wiper 18 and so the system will not recognise it as an edge. However, cameras that are capable of sharply capturing moving wipers may be used in which case correction must be made such that the wiper edges are not unduly counted.

In another improvement, the system is adapted to detect the presence of mist on the windscreen. This can be demonstrated with reference to

Figures 8a to 8c of the accompanying drawings, which depict views captured from the camera 10, and Figure 12 of the accompanying drawings, which show the steps taken. In normal view, without the backlight illuminated 220 (Figure 8a of the accompany drawings), the camera views the background scene and any raindrops on the windscreen. The average intensity surrounding the specular reflections of the backlight is measured 222. The backlight 21 is then turned on 224. In the lack of mist, illuminating the backlight 21 (Figure 8b of the accompanying drawings) does not have any great effect on the average intensity surrounding the specular reflections 53 of the backlight. However, if mist is present (Figure 8c of the accompanying drawings) then large amounts of diffuse, non-specular, reflection occur, and the intensity in the region surrounding the specular reflections of the backlight is greatly increased. Therefore, if the average intensity around the specular reflections 53 is calculated 226 and the difference between the two measured average intensities taken 228, the presence of mist can be detected as a large difference. This can then be monitored by the system, which can activate 230 demisting heaters, blowers and so on as appropriate.

20

Figure 11 of the accompanying drawings shows how the system herein described is advantageously used in combination with a lane detection technique. The video camera 10, the frame grabber 19 (that part of the processor 12 adapted to capture images from the camera 10) and the vertical edge detection 17 are all identical for both the rain detection technique described herein and a lane detection technique. The same processor may therefore run the same instructions on the same data. Only the thresholding 15, edge counting 13 and wiper control 11 add to the processing and hardware requirements.

30

CLAIMS

1. A rain detection apparatus, comprising a camera adapted to view a surface and a processor adapted to capture at least one image from the camera, in which the processor is further adapted to generate at least one signal indicative of the presence of rain on the surface from information contained in the at least one captured image, in which the apparatus is adapted to capture images focussed at a plurality of distances.
2. A rain detection apparatus, comprising a camera adapted to view a surface and a processor adapted to capture at least one image from the camera, in which the processor is adapted to generate at least one signal indicative of the presence of rain on the surface from information contained in the at least one captured image, in which the processor includes edge detection means adapted to detect edges visible in the at least one captured image and difference means adapted to calculate the difference between the number of edges visible between differing images.
3. A rain detection apparatus, comprising a camera adapted to view a surface and a processor adapted to capture at least one image from the camera, in which the processor is adapted to generate at least one signal indicative of the presence of rain on the surface from information contained in the at least one captured image, in which the processor includes edge detection means adapted to detect edges visible in the at least one captured image, the edge detection means being further adapted to disregard edges close to areas of light larger than the largest raindrop that is desired or expected to be detected.
4. The apparatus of claim 2 or claim 3, in which the apparatus is adapted to capture images focussed at a plurality of images.

5. The apparatus of claim 1, in which the processor includes edge detection means adapted to detect edges visible in the at least one captured image.
- 5
6. The apparatus of claim 3 or claim 5, in which the processor includes difference means adapted to calculate the difference between the number of edges visible between differing images.
- 10 7. The apparatus of claim 2 or claim 5, in which the edge detection is further adapted to disregard edges close to areas of light larger than the largest raindrop that is desired or expected to be detected.
8. The apparatus of any preceding claim, further comprising a
15 backlight adapted to illuminate the surface.
9. The apparatus of claim 8 in which the backlight is adapted to illuminate the surface with a given range of frequencies, and in which the apparatus further comprises an optical bandpass filter which preferentially
20 allows the given range of frequencies to pass.
10. The apparatus of claim 8 or claim 9, when dependent on claim 2 or claim 6, in which the difference means calculates the difference between the numbers of edges visible in captured images with and without the
25 backlight illuminated.
11. The apparatus of Claim 2, 3, or 5 or any claim dependent thereon, wherein the edge detection means is provided by convolving the image with a filter.

12. The apparatus of Claim 11, wherein the filter comprises a Sobel-like mask.
13. The apparatus of claim 11 when dependent on claim 3 or claim 7 in
5 which the mask comprises a central peak and two troughs spaced on either side of the central peak in convolution space.
14. The apparatus of claim 1 or claim 4 or any claim dependent
10 thereon in which the camera is adapted to be focussed at a plurality of distances.
15. The apparatus of claim 14 in which the camera is provided with a multi-focal lens.
- 15 16. The apparatus of claim 1 or claim 4 or any claim dependent thereon, adapted to sense the location of other vehicles or of lane markings on a road in which the vehicle to which the system is fitted is situated.
- 20 17. The apparatus of claim 10 or any claim dependent thereon in which the difference means is adapted to subtract the number of edges due to specular reflection of the backlight on the surface from the number of edges detected.
- 25 18. The apparatus of claim 8 or any claim dependent thereon, in which the apparatus is adapted to detect the presence of mist on the surface, in which the processor is adapted to calculate the difference in intensity of the captured image in the area around, but not including, the area of the image in which the specular reflection of the backlight on the surface is
30 found, between captured images in which the backlight is illuminated and where it is not.

19. The apparatus of any preceding claim in which the surface is a vehicle window or a cover or lens of a vehicle headlight.

5 20. An apparatus according to any preceding claim, adapted to control a cleaning apparatus for a vehicle window or a cover of a vehicle light.

21. A method of detecting the presence of obscuring material on a surface, the method comprising capturing images of the surface and then
10 calculating one or more characteristics of the condition of the surface from the captured images, in which the method includes the step of capturing images focussed at a plurality of distances.

22. A method of detecting the presence of obscuring material on a
15 surface, the method comprising capturing images of the surface and then calculating one or more characteristics of the condition of the surface from the captured images, in which the method includes the steps of detecting edges visible in the images and of taking the difference between the number of edges visible between differing images.

20 23. A method of detecting the presence of obscuring material on a surface, the method comprising capturing images of the surface and then calculating one or more characteristics of the condition of the surface from the captured images, in which the method includes the steps of
25 detecting edges visible in the images, with the method adapted to disregard edges close to areas of light larger than the largest raindrop that is desired or expected to be detected.

24. The method of claim 22 or claim 23 in which the method includes
30 the step of capturing images focussed a plurality of distances.

25. The method of claim 21 in which the method includes the step of detecting edges in the at least one captured images.
26. The method of claim 23 or claim 25 in which the method includes
5 the step of taking the difference between the number of edges visible between differing images.
27. The method of claim 22 or claim 25 in which the method includes
10 the step of disregarding edges close to areas of light larger than the largest raindrop that is desired or expected to be detected.
28. The method of claim 21 or claim 24, further including detecting
15 the positions of lanes or vehicles surrounding a vehicle from information contained in the at least one captured image.
29. The method of claim 22 or claim 26 in which the method includes
20 the steps of taking the difference between the numbers of edges visible between images captured with and without a backlight illuminating the surface.
30. The method of any one of claims 22 to 29 in which the surface
25 comprises a vehicle window, or the cover for a light of a vehicle.
31. The method of claim 22 or claim 26 or any claim dependent
thereon, in which the at least one captured image is partially focussed on
the vehicle window and on the road ahead of the vehicle.
32. The method of claim 22, claim 23 or claim 25, or any claim
30 dependent thereon, in which the edges are detected by convolving the or each captured image with a mask.

33. The method of claim 32 in which the mask is a Sobel-like mask.
34. The method of claim 32 when dependent on claim 23 or claim 27 in which the mask comprises a central peak and two troughs spaced in
5 opposite directions in convolution space therefrom.
35. The method of claim 34 in which the peak and the troughs each have linear rising and falling edges.
- 10 36. The method of claim 34 or 35 in which at least one of the peak and the troughs have a constant maximum absolute value of non-zero width in convolution space.
- 15 37. The method of claim 22, 23, or 24, or any claim dependent thereon, in which edges that are new compared with a previous image are counted.
- 20 38. The method of claim 29 or any claim dependent thereon, in which the number of edges due to specular reflection of the backlight on the surface is also subtracted from the number of edges detected with the backlight illuminated.
- 25 39. The method of any one of claims 22 to 38 further including the step of controlling vehicle window cleaning apparatus according to the sensed vehicle window condition.
- 30 40. The method of any one of claims 22 to 39 in which the amount of rain detected on the windscreen is integrated over time, such that the amount of time that rain has been present on the surface is taken into account.

41. The method of claim 40, further including the step of causing the surface to be cleaned when the integrated value exceeds a predetermined limit.
- 5 42. The method of any one of claims 22 to 41, in which the method is further adapted to detect the presence of mist, the method further including the steps of calculating the difference in intensity of the captured image between images in which a backlight is illuminated and where it is not in the area around, but not including, the area of the image
10 in which the specular reflection of the backlight is found.

1/10

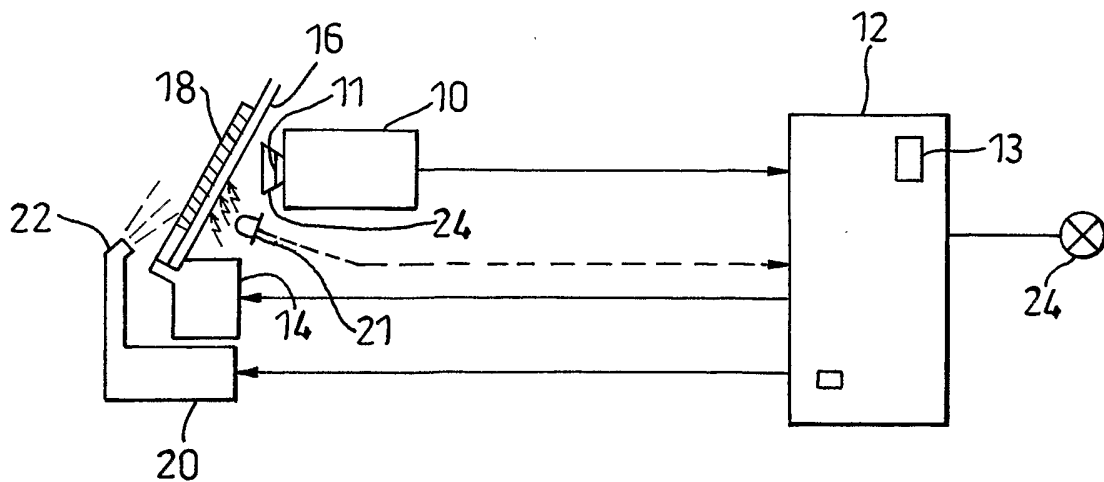

Fig. 1

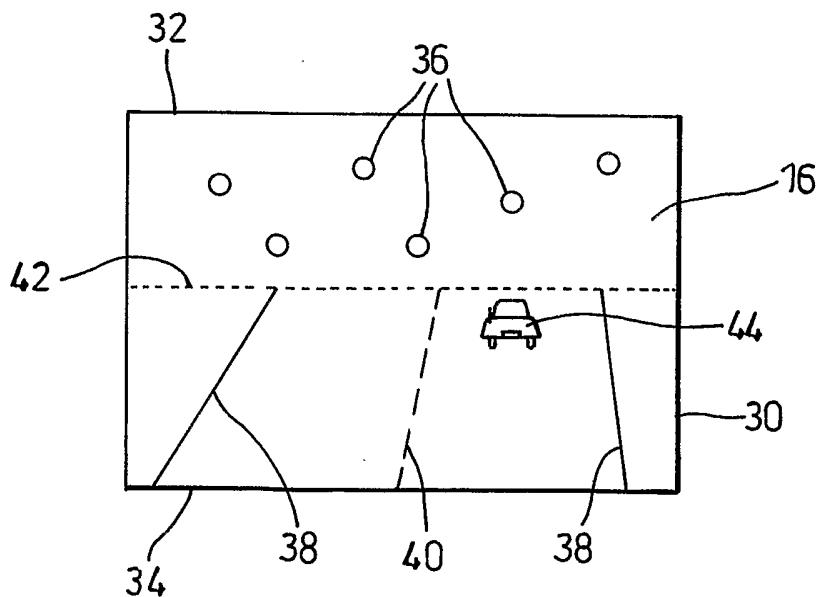

Fig. 2

2/10

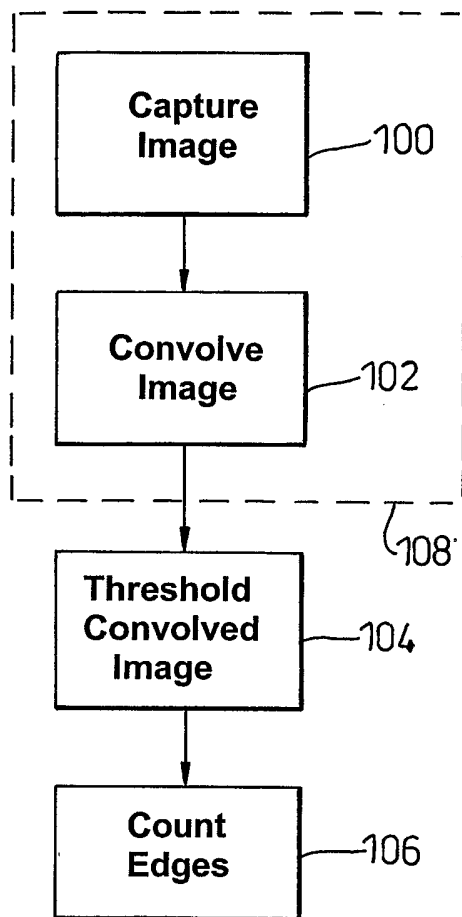

Fig. 3

3/10

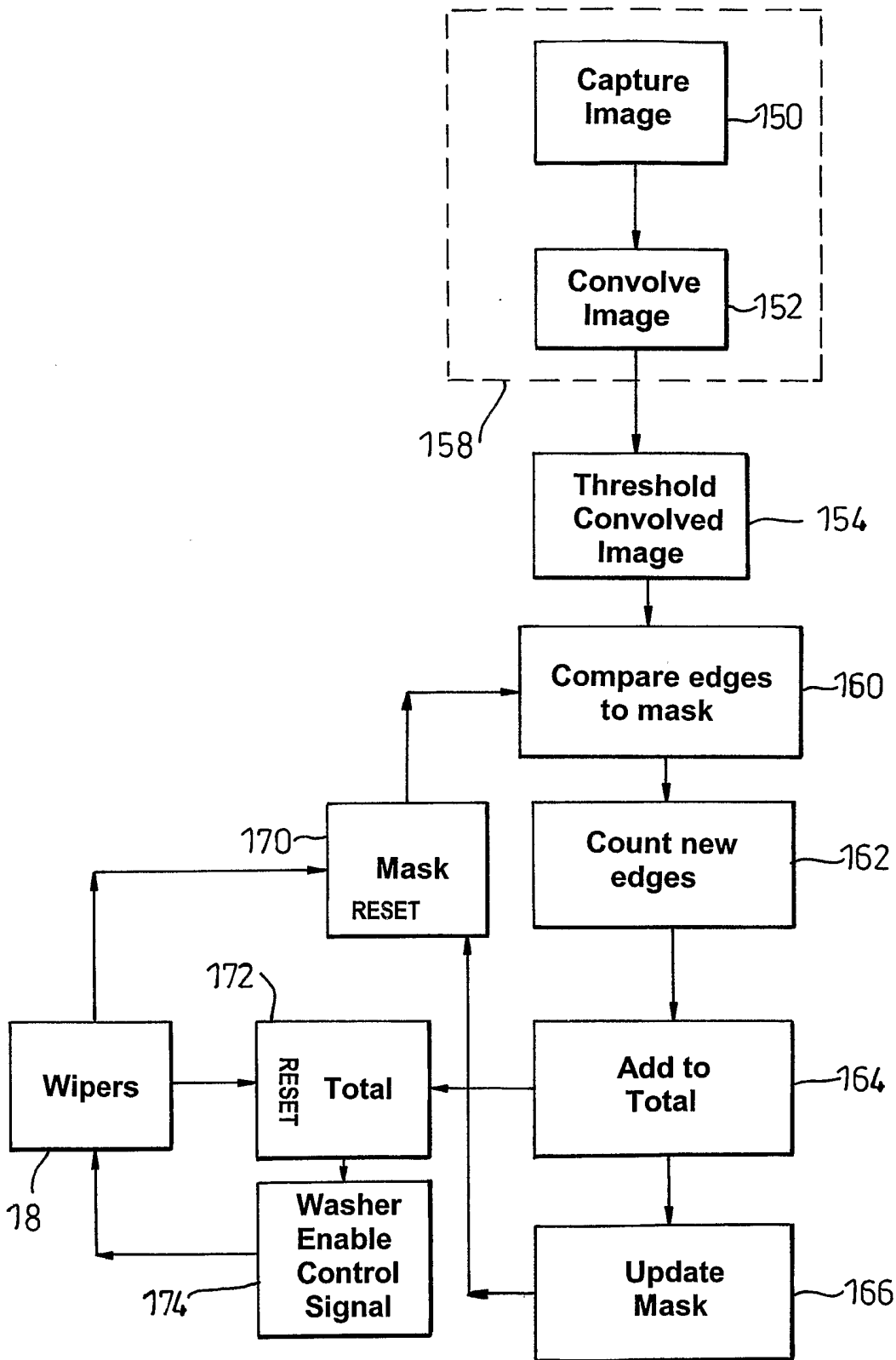

Fig. 4

4/10

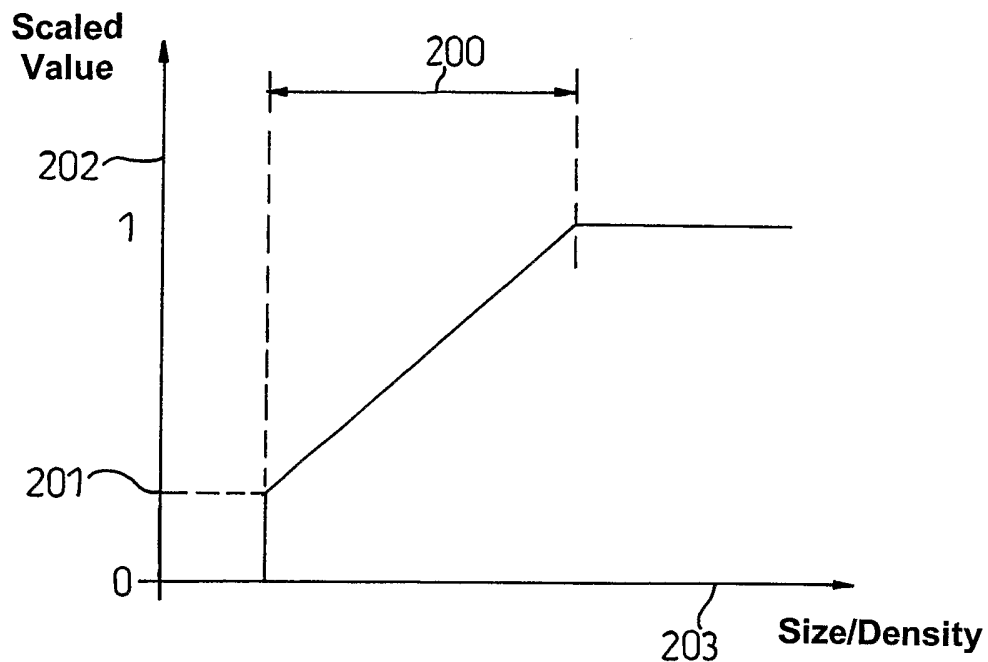

Fig. 5

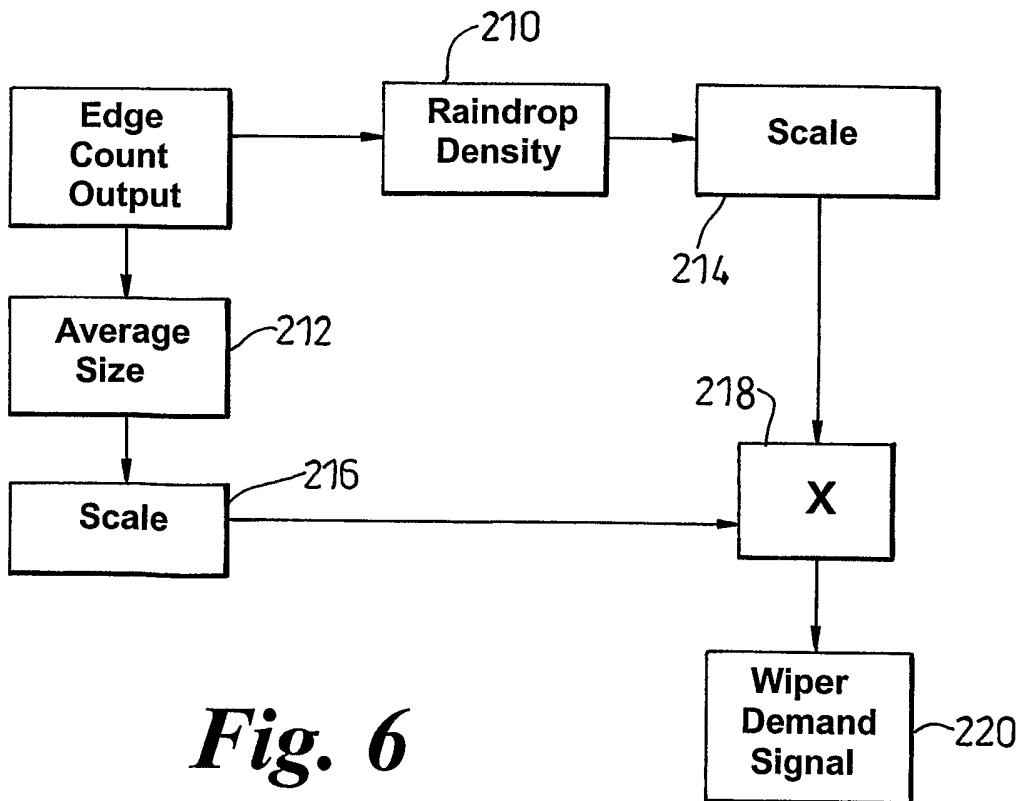

Fig. 6

5/10

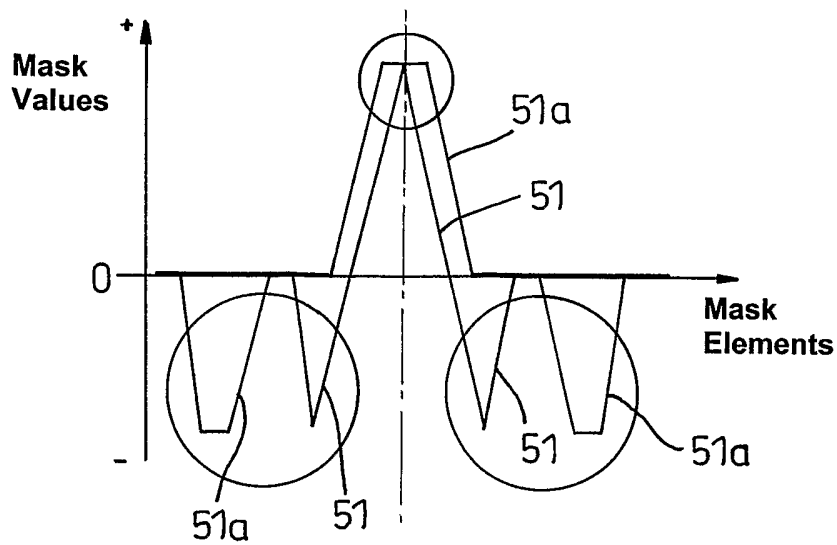

Fig. 7

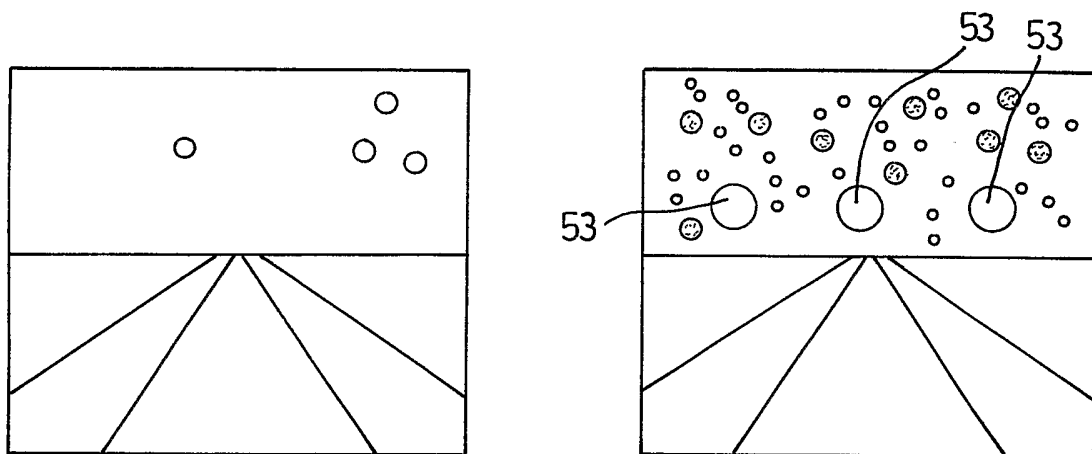

Fig. 8a

Fig. 8b

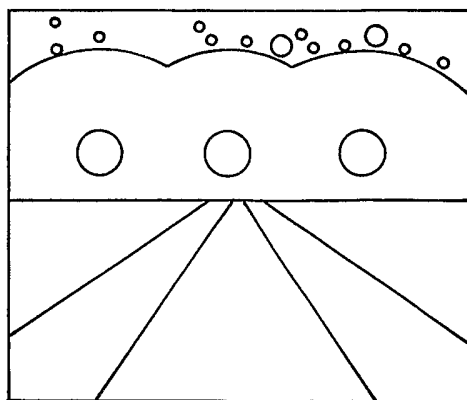
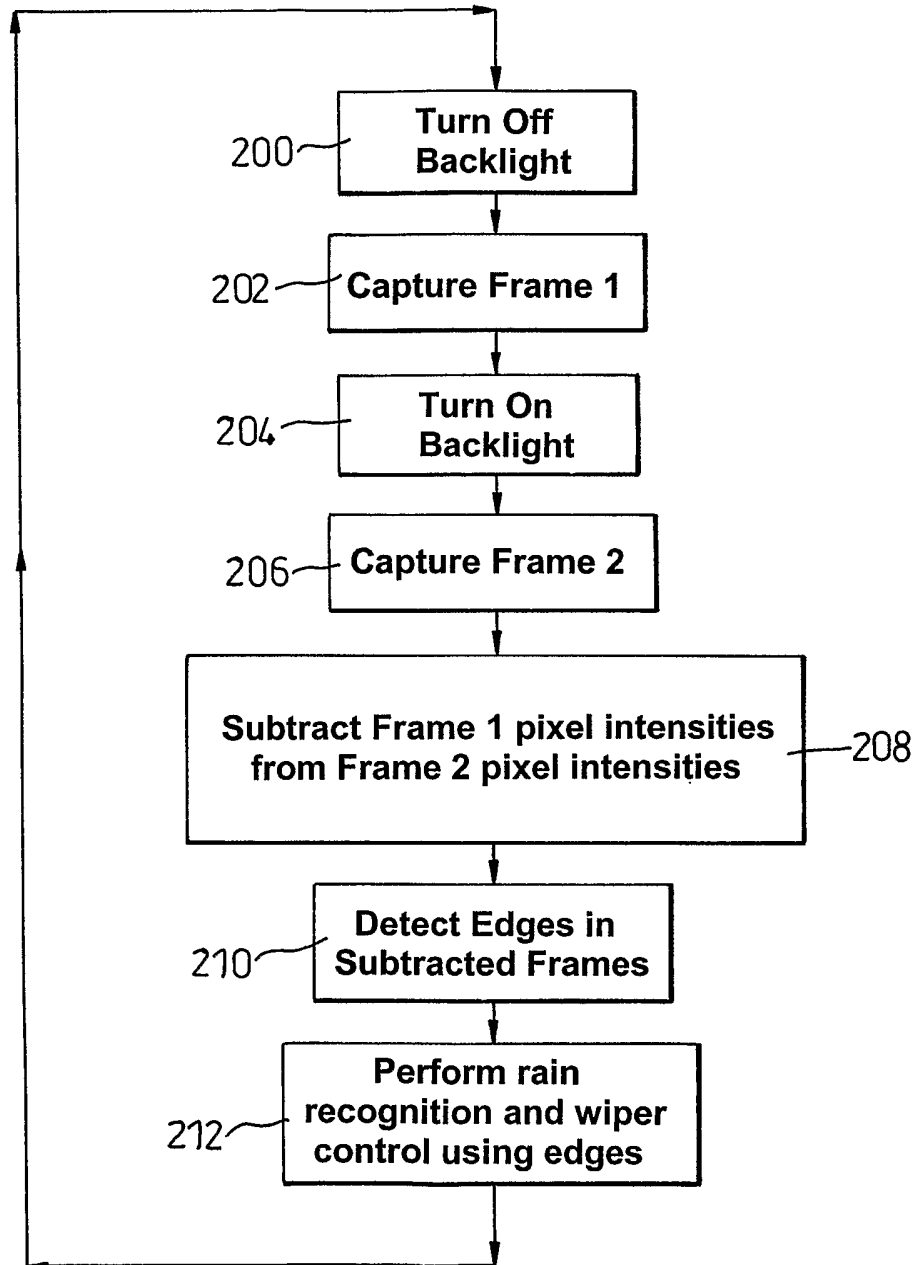

Fig. 8c

6/10



Frame Subtraction Control Diagram

Fig. 9

7/10

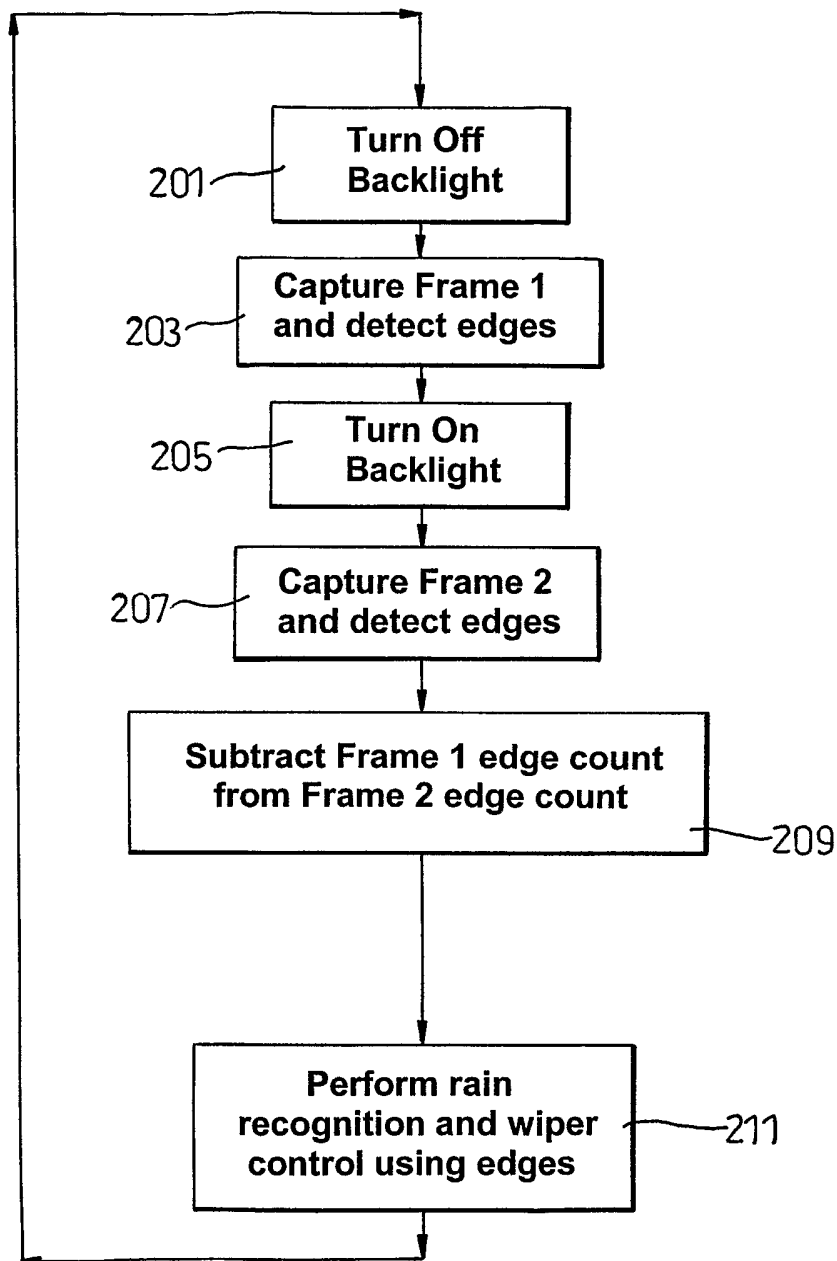

Edge Count Subtraction Control Diagram

Fig. 10

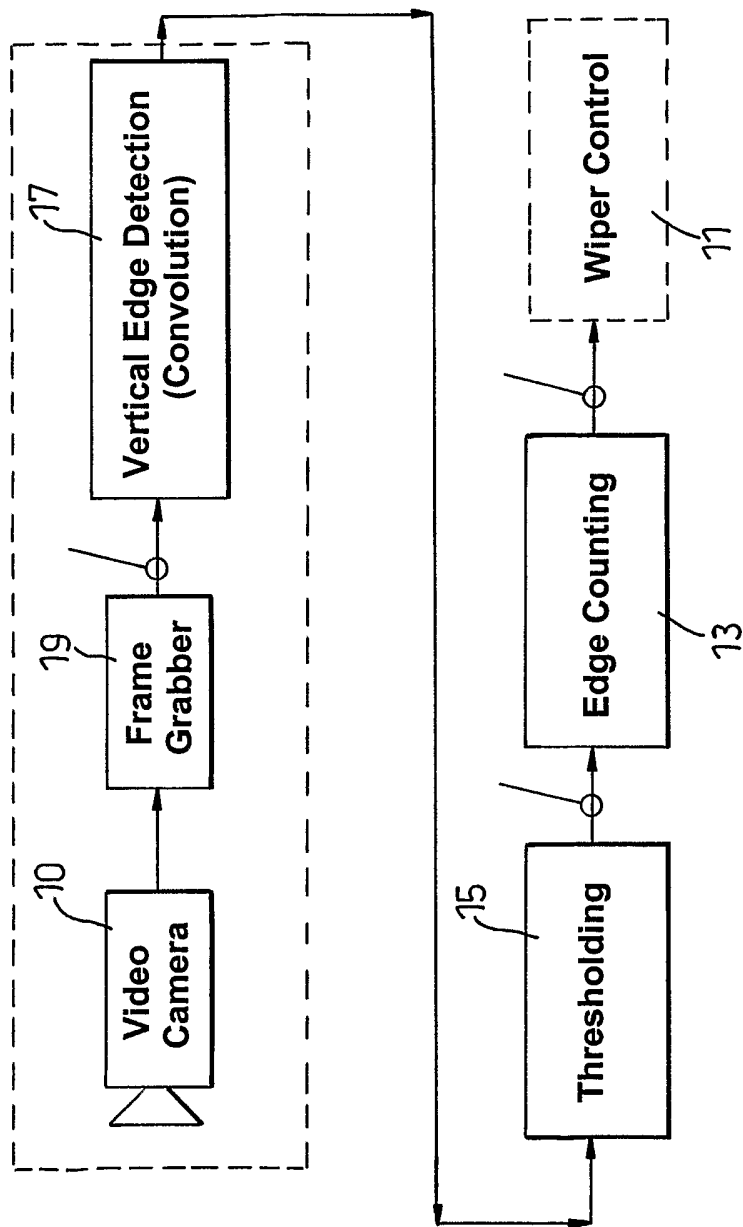

Fig. 11

9/10

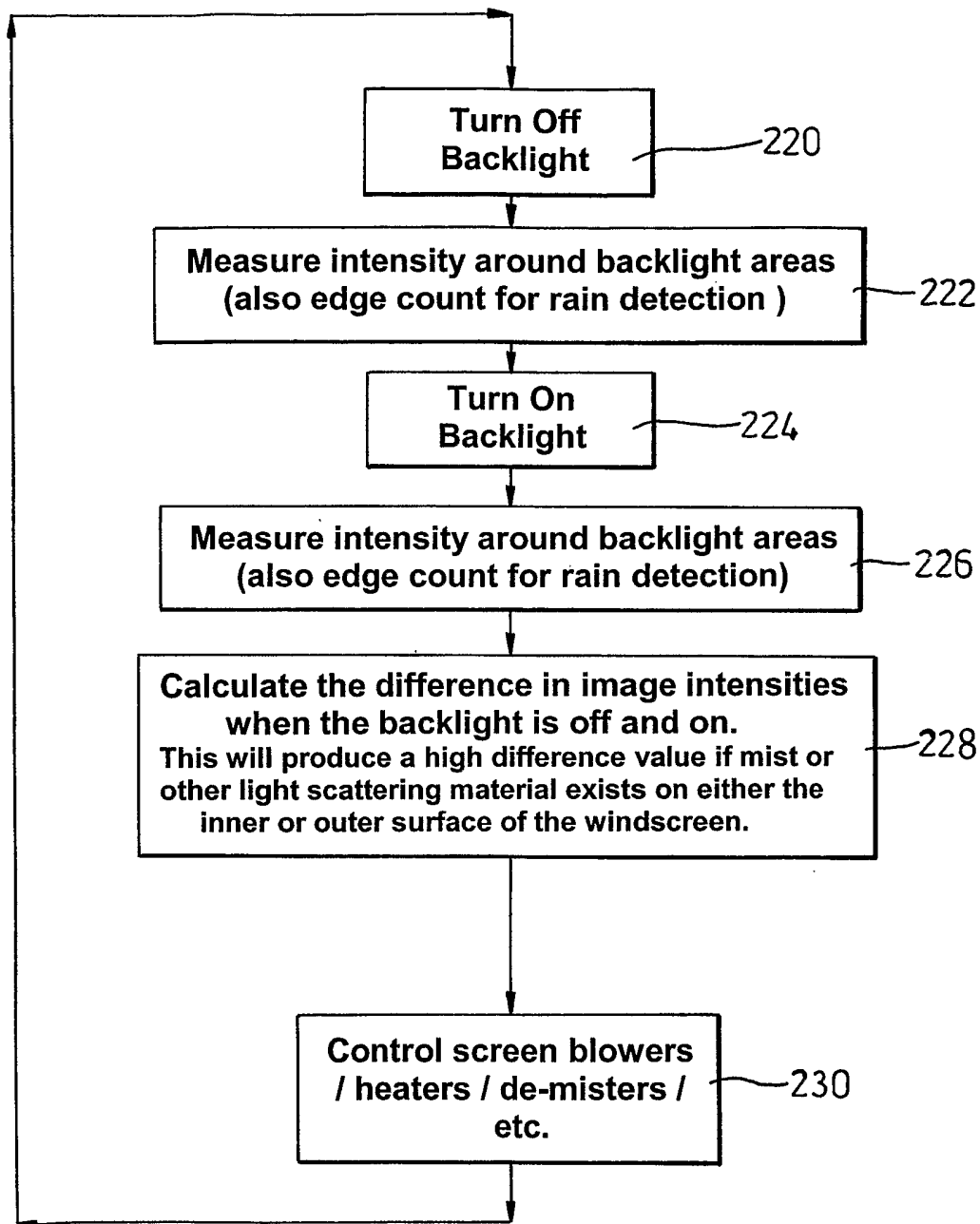

Fig. 12

10/10

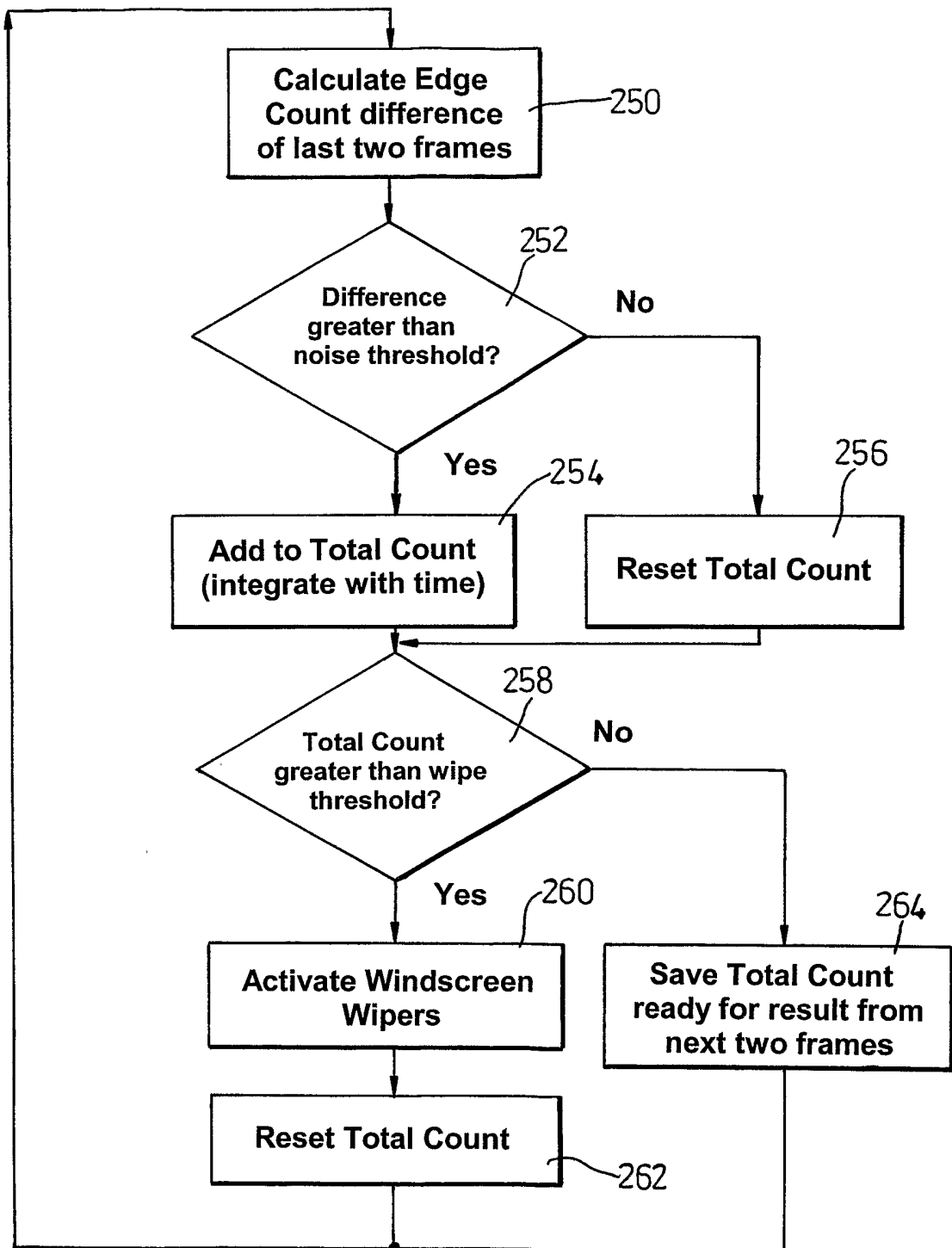

Fig. 13