

(12) STANDARD PATENT
(19) AUSTRALIAN PATENT OFFICE

(11) Application No. **AU 2003258438 B2**

(54) Title
Longitudinal support

(51) International Patent Classification(s)
A61B 17/70 (2006.01)

(21) Application No: **2003258438** (22) Date of Filing: **2003.09.08**

(87) WIPO No: **WO05/023125**

(43) Publication Date: **2005.03.29**

(43) Publication Journal Date: **2005.05.05**

(44) Accepted Journal Date: **2009.07.09**

(71) Applicant(s)
Synthes GmbH

(72) Inventor(s)
Hartmann, Stephan; Studer, Armin

(74) Agent / Attorney
Phillips Ormonde Fitzpatrick, 367 Collins Street, Melbourne, VIC, 3000

(56) Related Art
DE 9004960
US 6296644
WO 2003/068088

(12) NACH DEM VERTRAG ÜBER DIE INTERNATIONALE ZUSAMMENARBEIT AUF DEM GEBIET DES PATENTWESENS (PCT) VERÖFFENTLICHTE INTERNATIONALE ANMELDUNG

(19) Weltorganisation für geistiges Eigentum
Internationales Büro



(43) Internationales Veröffentlichungsdatum
17. März 2005 (17.03.2005)

PCT

(10) Internationale Veröffentlichungsnummer
WO 2005/023125 A1

(51) Internationale Patentklassifikation⁷: A61B 17/70

(CH). STUDER, Armin [CH/CH]; Stöcklimattstr. 15, CH-4513 Langendorf (CH).

(21) Internationales Aktenzeichen: PCT/CH2003/000605

(74) Anwalt: LUSUARDI, Werther; Dr. Lusuardi AG, Kreuzbühlstrasse 8, CH-8008 Zürich (CH).

(22) Internationales Anmeldedatum:
8. September 2003 (08.09.2003)

(81) Bestimmungsstaaten (*national*): AE, AG, AL, AM, AT, AU, AZ, BA, BB, BG, BR, BY, BZ, CA, CH, CN, CO, CR, CU, CZ, DE, DK, DM, DZ, EC, EE, EG, ES, FI, GB, GD, GE, GH, GM, HR, HU, ID, IL, IN, IS, JP, KE, KG, KP, KR, KZ, LC, LK, LR, LS, LT, LU, LV, MA, MD, MG, MK, MN, MW, MX, MZ, NO, NZ, OM, PH, PL, PT, RO, RU, SC, SD, SE, SG, SK, SL, TJ, TM, TN, TR, TT, TZ, UA, UG, US, UZ, VC, VN, YU, ZA, ZM, ZW.

(25) Einreichungssprache: Deutsch

(26) Veröffentlichungssprache: Deutsch

(71) Anmelder (für alle Bestimmungsstaaten mit Ausnahme von US): MATHYS MEDIZINALTECHNIK AG [CH/CH]; Güterstrasse 5, CH-2544 Bettlach (CH).

(84) Bestimmungsstaaten (*regional*): ARIPO Patent (GH, GM, KE, LS, MW, MZ, SD, SL, SZ, TZ, UG, ZM, ZW), eurasisches Patent (AM, AZ, BY, KG, KZ, MD, RU, TJ, TM), europäisches Patent (AT, BE, BG, CH, CY, CZ, DE,

(72) Erfinder; und

(75) Erfinder/Anmelder (nur für US): HARTMANN, Stephan [CH/CH]; Poststrasse 2, CH-4500 Solothurn

[Fortsetzung auf der nächsten Seite]

(54) Title: LONGITUDINAL SUPPORT

(54) Bezeichnung: LÄNGSTRÄGER

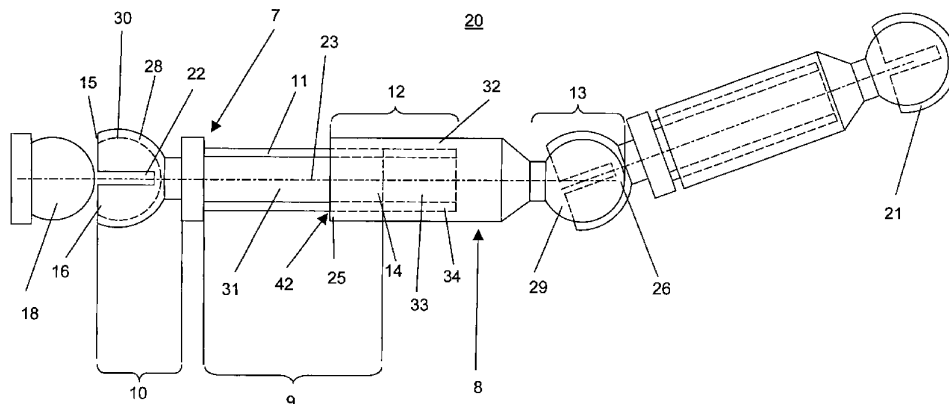

(57) Abstract: The invention relates to a longitudinal support element (7) having a longitudinal axis (23), two coaxial joining elements (9; 10), disposed one after the other, a first end (14) and a second end (15), the first joining element (9) having a thread that is coaxial to the longitudinal axis (23), whereby A) the second joining element (10) comprises a joint shell (28) which is axially open on the second end (15) of the longitudinal support element (7) and elastically deformable at an angle to the longitudinal axis (23); and B) the joint shell (28) comprises a cavity (30) in the shape of a hollow spherical segment and having a diameter D with an opening (16) that is concentric at the second end (15) to the longitudinal axis (23) and has a diameter d, with $d < D$.

(57) Zusammenfassung: Längsträgerelement (7) mit einer Längsachse (23), zwei hintereinander angeordneten, koaxialen Verbindungssegmenten (9;10), einem ersten Ende (14) und einem zweiten Ende (15), wobei das erste Verbindungssegment (9) ein zur Längsachse (23) koaxiales Gewinde aufweist, wobei A) das zweite Verbindungssegment (10) eine am zweiten Ende (15) des Längsträgerelementes (7) axial offene und quer zur Längsachse (23) elastisch deformierbare Gelenkschale (28) umfasst; und B) die Gelenkschale (28) eine hohlkugelsegmentartige Kavität (30) vom Durchmesser D mit einer am zweiten Ende (15) zur Längsachse (23) konzentrischen Öffnung (16) vom Durchmesser d umfasst, wobei $d < D$ ist.



WO 2005/023125 A1



DK, EE, ES, FI, FR, GB, GR, HU, IE, IT, LU, MC, NL,
PT, RO, SE, SI, SK, TR), OAPI Patent (BF, BJ, CF, CG,
CI, CM, GA, GN, GQ, GW, ML, MR, NE, SN, TD, TG).

*Zur Erklärung der Zweibuchstaben-Codes und der anderen Ab-
kürzungen wird auf die Erklärungen ("Guidance Notes on Co-
des and Abbreviations") am Anfang jeder regulären Ausgabe der
PCT-Gazette verwiesen.*

Veröffentlicht:

— *mit internationalem Recherchenbericht*

Longitudinal support

The invention concerns a longitudinal support to stabilise bones, particularly
5 bodies of the vertebra and a device to stabilise bones, particularly bodies of the
vertebra.

A reference herein to a patent document or other matter which is given as prior
art is not to be taken as an admission that that document or matter was, in
10 Australia, known or that the information it contains was part of the common
general knowledge as at the priority date of any of the claims.

The current treatment of damaged or tumorous bodies of the vertebra
comprises usually the implanting of a rigid longitudinal support, anchored on the
15 bodies of the vertebra by bone anchoring means or a rigid bone plate. The
purpose of these devices is to prevent, by means of the rigid implants, the
movement of the bodies of the vertebra stabilised in this manner relative to one
another and to promote the fusion of adjacent bodies of the vertebra.

20 A device to stabilise the bodies of the vertebra using a multi-segmented
longitudinal support that can be fixed in a desirable form, is disclosed in FR 2
796 828 Jammet. By using this, the longitudinal support, comprising a plurality
of axial segments and intended for the stabilisation, can be joined with the head
segments of the pedicle screws or pedicle hooks, which for the purpose of
25 stabilisation are screwed into the pedicle of the corresponding body of the
vertebra, and can be adapted without using great force to suit the form specified
by the positions of the pedicle screws. It is a disadvantage of this device, that
the longitudinal support elements can be fastened individually on the head
segments of the pedicle screws or pedicle hooks and cannot be joined with one
30 another, so that each longitudinal support element has to be individually
inserted and placed into the body of the patient, representing to the surgeon a
tedious and time-consuming step of the operation.

According to the present invention, there is provided a device to stabilise bodies of vertebra with a longitudinal support, the device comprising:

5 A) a longitudinal support element with a longitudinal axis, two coaxial connecting segments provided behind one another, with a first end and a second end, wherein a first of the connecting segments has a thread extending parallel to the longitudinal axis, wherein

0 A.1) on the second end of the longitudinal support element a second of the connecting segments comprises a deformable articulated socket that is axially open and can be deformed transversely to the longitudinal axis,

and

A.2) the articulated socket comprises a hollow spherical segment-like cavity with a diameter of D with an opening on the second end that is concentric with the longitudinal axis and has a diameter of d , while $d < D$;

5 B) a second longitudinal support element with a longitudinal axis, wherein the second longitudinal support element comprises a first connecting segment that can be connected with the first connecting segment of the first longitudinal support element and a second connecting segment with an articulated head that is complementary to the articulated socket;

10 C) at least two bone anchoring means, each with: a central axis, an anchoring segment to fix the bone anchoring means on a bone, in particular on a body of the vertebra, and a head segment with means to accommodate the articulated socket; and

D) fixing means to fix the articulated sockets in the means to accommodate the articulated socket,

25 wherein

E) the fixing means comprise an elastically expandable clamp, that can be placed over the articulated socket and can be snapped onto the head segment of the bone fixing means, in such a manner that

F) after assembly, the articulated socket is compressed by the clamp.

30 According to the present invention, there is also provided a longitudinal support to stabilise bones, particularly bodies of the vertebra, including a first longitudinal support element as described above.

According to the present invention, there is further provided a device to stabilise bodies of the vertebra with a longitudinal support, as described above.

Advantageously, the present invention can provide a longitudinal support element with an articulated socket, in the cavity of which a complementary articulated head of a further longitudinal support element can be elastically snapped in, so that a longitudinal support, including a plurality of longitudinal support elements, can be pre-assembled outside of the patient's body.

The advantages achieved by the longitudinal support element of the present invention can include that:

- a longitudinal support, including a plurality of longitudinal support elements which can be joined with one another, can be pre-assembled,
- a longitudinal support can be adapted in-situ to suit the desired geometry without using any force,
- a implanting of a longitudinal support can be considerably simplified.

In a preferred embodiment the articulated socket can be made from a nickel-titanium alloy (Nitinol), wherein $45\% < \text{Ni} < 55\%$, $45\% < \text{Ti} < 55\%$ and $x + y = 100\%$. Such a material is biocompatible and highly elastic.

- 5 In another embodiment the articulated socket has an external spherical convex construction, thus achieving the advantage of a polyaxially pivotable accommodation of the articulated socket in, for example, a bone anchoring means constructed as a tulip screw.
- 10 In yet another embodiment the first connecting segment of the longitudinal support element includes an outside thread.

The advantages of the longitudinal support according to the invention can include that:

- 15 • a first longitudinal support element, having an articulated socket, can be polyaxially pivotably joined with a second longitudinal support element having a complementary articulated head, and
- a longitudinal support can be shaped to suit the anatomy.
- 20 In a preferred embodiment the connection between a first connecting segment of a first longitudinal support element and a first connecting segment of a second longitudinal support element can be axially lengthened or shortened, so that a first longitudinal support element can be coaxially joined with a second longitudinal support element and the length of the longitudinal support segment
- 25 formed by the two longitudinal support elements can be adjusted.

This longitudinally adjustable connection between the two longitudinal support elements can telescope or be realised as a screw joint. For this purpose the first connecting segment can be constructed as a coaxial shaft on the first

30 longitudinal support element and the thread be constructed as an outside thread and the first connecting segment constructed as a sleeve on the second longitudinal support element, the sleeve including a central bore with an inside thread that complements the outside thread.

In a further embodiment the articulated head has a spherical convex design and the cavity of the articulated socket is complementary to it.

5 In another embodiment the articulated head and the articulated socket can be elastically snapped into one another. This will bring the advantage, that a simple pre-assembly of a longitudinal support, including a plurality of longitudinal support segments, is possible.

10 In yet another embodiment the longitudinal support includes an end-piece with an articulated head that can be snapped into an articulated socket. This has the advantage that an articulated socket, provided at the end of the longitudinal support, will not be compressed when mounted in the receptacle on the head of a pedicle screw. The longitudinal support preferably includes a second end-piece with an articulated socket.

15 In a preferred embodiment the means to accommodate the articulated socket are constructed as a concave spherical recess, that complements the articulated socket.

20 In another embodiment the fixing means includes a tightening screw, that can be screwed into an inside thread in the head of the bone anchoring means, so that an articulated socket can be secured in the bone anchoring means using the fixing means.

25 In yet another embodiment the fixing means include an elastically expandable clamp, that can be placed over the articulated socket and can be snapped onto the head segment of the bone fixing means, while after the assembly of the clamp the articulated socket is compressed by the clamp. This will bring with it the advantage, that due to the compressing of the second articulated part the
30 articulation is locked between the two longitudinal support segments on the one hand and on the other hand the longitudinal support is fixed on this bone anchoring means.

The clamp has preferably a lug on each of its free end, that can be snapped onto the head segment of the bone anchoring means. For a better acceptance of the lugs notches, complementing the lugs, may be provided on the head segment.

5

The invention and developments of the invention are explained below in detail based on the partly schematic illustrations of several embodiments. They show in:

10 Fig.1 - a side view of an embodiment of the longitudinal support according to the invention, with type A and type B longitudinal support elements provided alternating behind one another,

15 Fig.2a - a longitudinal section through an embodiment of the device according to the invention,

Fig.2 b - a cross-section through the embodiment of the device according to the invention and illustrated in Fig.2a, and

20 Fig.3 - a cross-section through another embodiment of the device according to the invention.

Fig.1 illustrates an embodiment of the longitudinal support 20 with type A and type B longitudinal support elements 7, 8 provided alternating behind one another and with an end-piece 18, 21 at each end. The connecting segments 9, 10, 12, 13 of both longitudinal support elements 7, 8 are so constructed, that a first connecting segment 9 of a first longitudinal support element 7 (type A) forms with a second longitudinal support element 8 (type B) a coaxial connection, that can be adjusted only axially longitudinally, while a second connecting element 10 of a first longitudinal support element 7 (type A) with a second connecting element 13 of a second longitudinal support element 8 (type B) allows a polyaxially pivotable connection of the two longitudinal support elements 7, 8. In this case the first two connecting segments 9, 12 can be particularly joined by a thread connection 42, in such a manner that the first

25
30

longitudinal axis 23 of the longitudinal support element 7 (type A) and the second longitudinal axis 24 of the longitudinal support element 8 (type B) are arranged coaxially. In this case the thread connection 42 is so constructed, that the first connecting segment 9 of the first longitudinal support element 7 (type A) includes a shaft 31 with an outside thread 11 and the first connecting segment 12 of the second longitudinal support element 8 (type B) includes a sleeve 32 with a central bore 42 having an inside thread 34 that complements the outside thread 11. The construction of the threaded bore 42 could be constructed by interchanging the connecting segments 9, 12.

The longitudinal support element 7 (type A) includes two connecting segments 9, 10, which are coaxial with the first longitudinal axis 23 and are provided behind one another and at the ends a first and a second end 14, 15. In this conjunction the first connecting element 9 of the longitudinal support element 7 (type A) is constructed as a cylindrical shaft 31 with a thread 11. The second connecting segment 10 of the longitudinal support element 7 (type A) includes an articulated socket 28 with a hollow spherical segment-like, coaxial cavity 30, said socket can be elastically deformed transversely to the first longitudinal axis 23, while said cavity at the second end 15 of the longitudinal support element 7 has an opening 16 that is concentric with the first longitudinal axis 23. An articulated head 29, which has a construction complementing the cavity 30, can be introduced into the cavity 30 through the opening 16, so that the articulated head 29 and the articulated socket 28 form a ball and socket joint. The two longitudinal support elements 7, 8 (types A and B), connected in this manner, are then displaceable relative one another in such a manner, that the first and the second longitudinal axis 23, 24 can pivot relative one another about the centre of the articulate joint. Furthermore, the cavity 30 has a diameter D , that is greater than the diameter d of the opening 16, so that an articulated head 29, introduced into the cavity 30, is axially enclosed by more than 180° . In addition, the articulated socket 28 is provided with four slots 22 which are parallel to the longitudinal axis 23 and pass through from the outside to the cavity 30 and allow a radial elastic deformation of the articulated socket 28.

The longitudinal support element 8 (type B) includes also two connecting segments 12, 13 provided coaxially with its longitudinal axis 24 behind one another, as well as a first and a second end 25, 26 at its ends. The first connecting element 12 of the longitudinal support element 8 (type B) is
5 constructed as a sleeve 32 that is coaxial with the second longitudinal axis 24 and has a central bore 33, while the central bore 33 is provided with an inside thread 34, that is complementary to the thread 11. The second connecting element 13 of the longitudinal support element 8 (type B) is constructed as a spherical articulated head 29, that is complementary to the articulated socket
10 28.

The first end-piece 18 has an analogous construction with the articulated head 29, while the second end-piece 21 has an analogous construction with the articulated socket 28. The two end-pieces 18, 21 allow to accommodate the
15 articulated socket 28 and the articulated head 29, respectively, in, for example, a commercially available pedicle screw or pedicle hook with a spherical concave recess 36 (Fig.2).

In Figs.2a and 2b a detail of an embodiment of the device 1 to stabilise bodies
20 of the vertebra with a longitudinal support 20 according to Fig.1 are illustrated with two bone anchoring means 3, connected by the longitudinal support 20, while the bone anchoring means 3 are constructed in this case as pedicle screws. The longitudinal support 20 includes several longitudinal support elements 7, 8 (type A and type B) provided alternating behind one another,
25 wherein in the detail illustrated here two longitudinal support elements 7 (type A) are articulately connected via their first connecting segments 9 with the first connecting segments 12 of two longitudinal support elements 8 (type B) and the longitudinal support element 7 (type A) is connected with the longitudinal support element 8 (type B) via its second connecting segment 10 in such a
30 manner that it can be only axially displaceable. The articulated heads 29 of the second longitudinal support elements 8 (type B) are snapped into the articulated sockets 28 of the adjacent first longitudinal support elements 7 (type A). To connect the head segments 6 of the bone anchoring means 3 with the articulated sockets 29, channels 50 are provided on the head segments 6, with

channel axes 53 extending transversely to the central axis 3 of the bone anchoring means 3. The channels 50 pass through the head segments 6 of the bone anchoring means 3 transversely to the central axis 3 and are open to the free end 52 of the head segment 6. For a polyaxially pivotable mounting of the articulated sockets 28 in the channels 50, they have spherical recesses 36 at the bottom of the channels 50, which complement the articulated sockets 28. The head segments 6 further include bores 55, penetrating from the free end 52, with inside threads 54. The fixing means 27 to fix the articulated sockets 28 are constructed in this case as tightening screws 37, which can be screwed into the inside thread 54 from the free end 52 of the head segment 6, so that the articulated sockets 28, placed into the channels 50, together with the snapped-in articulated heads 29, can be fixed in the channels 50 by tightening the tightening screws 37. When fixing the articulated sockets 28, they are compressed transversely to the longitudinal axes 23 of the first longitudinal support elements 7 (type A), due to which the snapped-in articulated heads 29 of the second longitudinal support elements 8 (type B) are blocked in the articulated sockets 28.

The embodiment of the device 1 illustrated in Fig.3 differs from that illustrated in Figs.2a and 2b only by that the fixing means 27 is constructed as a clamp 38, the legs 43 of which can be elastically expanded, so that the clamp 38 can be guided over the articulated socket 28 and can be snapped onto the head segment 6 of the bone fixing means 3 by its elastic spring-back in such a manner, that after being assembled the articulated socket 28 is compressed by the clamp 38. Thus the articulated socket 28 is secured in the head segment 6 of the bone anchoring means 3 first by virtue of the clamp 38 and, in addition, by compressing the articulated socket 28 the articulated head 29 snapped in the articulated socket 28 is locked in the head segment 6 of the bone anchoring means 3. To fasten the clamp 38 on the head segment 6, the clamp 38 has at the free ends 39 of both legs 43 an inward directed lug 40, that can snap into the complementary notches 41, arranged at the fixed end 51 of the head segment.

Description of the operation:

2003258438 31 Mar 2009
5 First of all the bone anchoring means 3, in particular the pedicle screws or pedicle hooks are placed by the surgeon onto the pedicles of the bodies of the vertebra to be fixed. After this the longitudinal support elements 7, 8 (type A and type B) are joined alternating together outside of the patient's body, until the longitudinal support 20 has the desired length and contains the desired number of joints. The assembled longitudinal support 20 is then introduced into the patient's body by a minimally invasive incision and placed below the soft tissue surrounding the body of the vertebra to be fixed and bent at the articulated joints until it has the desired shape and the articulated heads 29 are introduced into the means 35 to accommodate the articulated heads 29 on the bone anchoring means 3. Following this the fixing means 27 are pre-assembled on the head segments 6 of the bone anchoring means 3, i.e. not yet locked, so that the longitudinal support 20 can still be adjusted. At this stage
5 the shape of the longitudinal support 20, as well as the distances of the individual longitudinal support elements 7, 8 are still flexibly adjustable. As soon as the desired shape of the longitudinal support 20 is set, the fixing means 27 are locked and consequently the entire fixing device is fixed.

10 The invention described herein is susceptible to variations, modifications and/or additions other than those specifically described and it is to be understood that the invention includes all such variations, modifications and/or additions which fall within the spirit and scope of the present disclosure.

25 Throughout the description of this specification the word "comprise" and variations of that word, such as "comprises" and "comprising", are not intended to exclude other additives or components or integers.

THE CLAIMS DEFINING THE INVENTION ARE AS FOLLOWS:

1. A device to stabilise bodies of vertebra with a longitudinal support, the device comprising:

5 A) a longitudinal support element with a longitudinal axis, two coaxial connecting segments provided behind one another, with a first end and a second end, wherein a first of the connecting segments has a thread extending parallel to the longitudinal axis, wherein

0 A.1) on the second end of the longitudinal support element a second of the connecting segments comprises a deformable articulated socket that is axially open and can be deformed transversely to the longitudinal axis,

and

5 A.2) the articulated socket comprises a hollow spherical segment-like cavity with a diameter of D with an opening on the second end that is concentric with the longitudinal axis and has a diameter of d , while $d < D$;

10 B) a second longitudinal support element with a longitudinal axis, wherein the second longitudinal support element comprises a first connecting segment that can be connected with the first connecting segment of the first longitudinal support element and a second connecting segment with an articulated head that is complementary to the articulated socket;

25 C) at least two bone anchoring means, each with: a central axis, an anchoring segment to fix the bone anchoring means on a bone, in particular on a body of the vertebra, and a head segment with means to accommodate the articulated socket; and

30 D) fixing means to fix the articulated sockets in the means to accommodate the articulated socket,

wherein

35 E) the fixing means comprise an elastically expandable clamp, that can be placed over the articulated socket and can be snapped onto the head segment of the bone fixing means, in such a manner that

F) after assembly, the articulated socket is compressed by the clamp.

2. A device according to claim 1, wherein the articulated socket is made from Nitinol.

- 5
- 0
- 5
- 10
- 25
- 30
3. A device according to claim 1 or 2, wherein the articulated socket has an external spherical convex construction.
 4. A device according to any one of claims 1 to 3, wherein the first connecting element comprises an outside thread that is coaxial with the longitudinal axis.
 5. A device according to any one of claims 1 to 4, wherein the connection between the first connecting segment of the first longitudinal support element and the first connecting segment of the second longitudinal support element can axially lengthened or shortened.
 6. A device according to claim 5, wherein the connection between the first connecting segment of the first longitudinal support element and the first connecting element of the second longitudinal support element can telescope.
 7. A device according to claim 5, wherein the connection between the first connecting segment of the first longitudinal support element and the first connecting element of the second longitudinal support element is a screw connection.
 8. A device according to any one of claims 1 to 7, wherein the articulated head has a spherical convex construction that is complementary to the cavity.
 9. A device according to any one of claims 1 to 8, wherein the articulated head and the articulated socket can be elastically snapped into one another.
 10. A device according to any one of claims 7 to 9, wherein
 - a) the first connecting segment on the first longitudinal support element is constructed as a shaft and the thread is constructed as an outside thread, and
 - b) the first connecting segment of the second longitudinal support element is constructed as a sleeve, that includes a central bore with an inside thread that complements the outside thread.
 11. A device according to any one of claims 1 to 10, wherein the device comprises at least one end-piece with an articulated head.

- 5 12. A device according to any one of claims 1 to 11, wherein the device comprises at least a second end-piece with an articulated socket.
13. A device according to any one of claims 1 to 12, wherein to accommodate the articulated socket, the means to accommodate the articulated socket comprise a concave spherical recess that complements the articulated socket.
- 0 14. A device according to any one of claims 1 to 13, wherein the fixing means include a tightening screw, that can be screwed into an inside thread in the head of the bone anchoring means.
- 5 15. A device according to any one of claims 1 to 14, wherein the clamp has a lug on each free end of the clamp that can be snapped onto the head segment of the bone anchoring means.
16. A device according to claim 15, wherein the head segment comprises notches, complementing the lugs.
- 10 17. A device according to any one of the embodiments substantially as herein described.

Abstract

A longitudinal support element (7) with a longitudinal axis (23), two coaxial connecting segments (9, 10) provided behind one another, with a first end (14) and a second end (15), wherein the first connecting segment (9) has a thread that is coaxial with the longitudinal axis (23), wherein

A) on the second end (15) of the longitudinal support element (7) the second connecting segment (10) comprises a deformable articulated socket (28) that is axially open and can be deformed transversely to the longitudinal axis (23), and

B) the articulated socket (28) comprises a hollow spherical segment-like cavity (30) with a diameter of D with an opening (16) on the second end (15) that is concentric with the longitudinal axis (23) and has a diameter of d , while $d < D$.

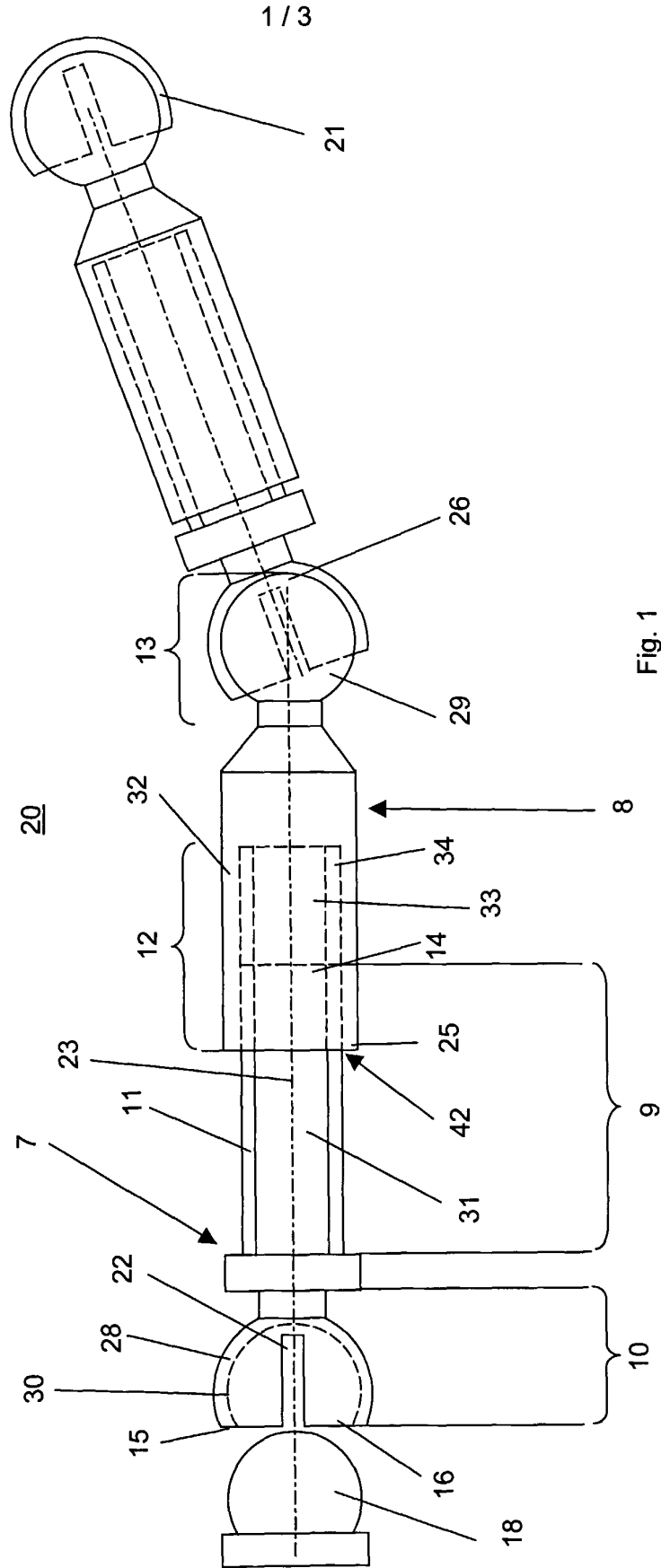

2 / 3

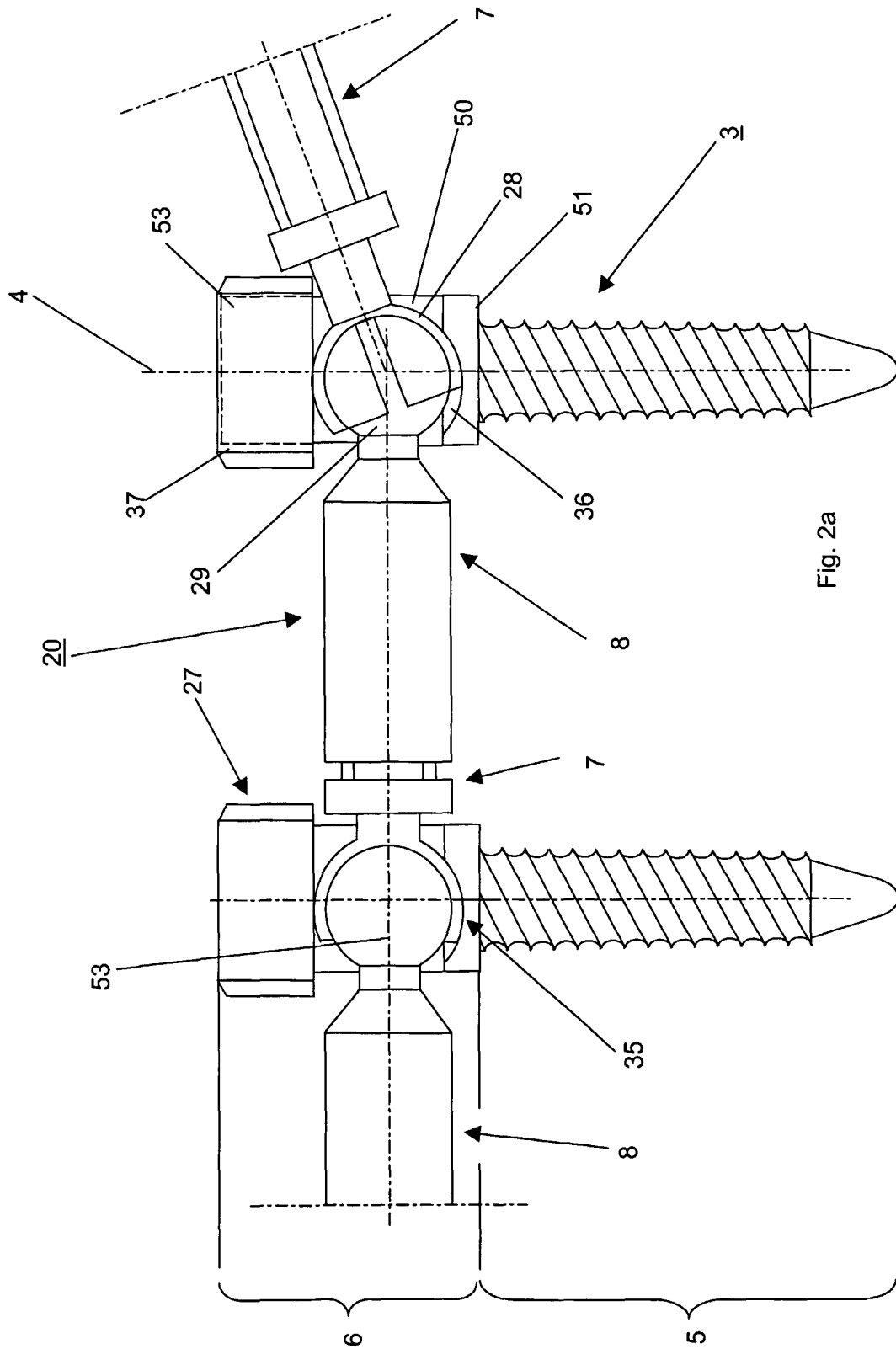

Fig. 2a

