

(19) **DANMARK**

(10) **DK/EP 3767480 T3**



(12) **Oversættelse af  
europæisk patentskrift**

Patent- og  
Varemærkestyrelsen

- 
- (51) Int.Cl.: **G 06 F 13/42 (2006.01)** **B 41 J 2/175 (2006.01)** **G 06 F 13/38 (2006.01)**
- (45) Oversættelsen bekendtgjort den: **2022-04-25**
- (80) Dato for Den Europæiske Patentmyndigheds bekendtgørelse om meddelelse af patentet: **2022-03-23**
- (86) Europæisk ansøgning nr.: **20190995.9**
- (86) Europæisk indleveringsdag: **2018-12-03**
- (87) Den europæiske ansøgnings publiceringsdag: **2021-01-20**
- (62) Stamansøgningsnr: **18821924.0**
- (84) Designerede stater: **AL AT BE BG CH CY CZ DE DK EE ES FI FR GB GR HR HU IE IS IT LI LT LU LV MC MK MT NL NO PL PT RO RS SE SI SK SM TR**
- (73) Patenthaver: **Hewlett-Packard Development Company, L.P., 10300 Energy Drive, Spring, TX 77389, USA**
- (72) Opfinder: **PANSHIN, Stephen D, 1070 NE Circle Blvd., Corvallis, OR 97330-4241, USA**  
**LINN, Scott A, 1070 NE Circle Blvd., Corvallis, OR 97330-4241, USA**
- (74) Fuldmægtig i Danmark: **NORDIC PATENT SERVICE A/S, Bredgade 30, 1260 København K, Danmark**
- (54) Benævnelse: **LOGIKKREDSLØB**
- (56) Fremdragne publikationer:  
**US-A1- 2011 029 705**  
**US-B1- 9 582 443**



# DESCRIPTION

## BACKGROUND

**[0001]** Serial data bus protocols such as Inter-integrated Circuits (I<sup>2</sup>C, or I2C, which notation is adopted herein) protocol and Serial Peripheral Interface (SPI) protocol allow at least one 'master' integrated circuit (IC) to communicate with at least one 'slave' IC, for example via a bus. I2C, and other communications protocols, communicate data according to a clock period. For example, a voltage signal may be generated, where the value of the voltage is associated with data. For example, a voltage value above x may indicate a logic "1" whereas a voltage value below x volts may indicate a logic "0", where x is a predetermined numerical value. By generating an appropriate voltage in each of a series of clock periods, data can be communicated via a bus or another communication link.

**[0002]** Some 2D and 3D printing systems include one or more replaceable print apparatus components, such as print material containers (e.g. inkjet cartridges, toner cartridges, ink supplies, build material supplies etc.), inkjet printhead assemblies, and the like. In some examples, logic circuitry associated with the replaceable print apparatus component(s) communicate with logic circuitry of the print apparatus in which they are installed, for example communicating information such as their identity, capabilities, status and the like.

**[0003]** In some examples, these communications utilize I2C communications. In such examples, the master IC may generally be provided as part of the print apparatus (which may be referred to as the 'host') and a replaceable print apparatus component would comprise a 'slave' IC, although this need not be the case in all examples. There may be a plurality of slave ICs connected to an I2C communication link (for example, containers of different colors of print agent). The slave IC(s) may comprise logic circuitry to perform data operations before responding to requests from logic circuitry of the print system.

**[0004]** In some examples, it may be intended to detect the physical location of slave devices that are attached along a serial bus. It may, for example, be intended that devices such as replaceable print apparatus components occupy a certain designated physical position within a print apparatus. For example, in a printing apparatus with ink supply devices attached to a serial bus, there may be an expected position for, for example, a black cartridge, a yellow cartridge, a cyan cartridge and a magenta cartridge, each of which may have a particular address under a communications protocol. By detecting whether specific ink color cartridges have been misinstalled or swapped, printing with incorrect or intended colors may be prevented. A prior patent disclosure is US patent application publication number US 2011/0029705. US9582443 describes a serial control channel processor for executing time-based instructions.

## SUMMARY OF INVENTION

**[0005]** The scope of the invention is defined by the appended claims.

**BRIEF DESCRIPTION OF DRAWINGS**

**[0006]** Non-limiting examples will now be described with reference to the accompanying drawings, in which:

Figure 1 is an example of a printing system;

Figure 2 is an example of a replaceable print apparatus component;

Figure 3 shows an example of a print apparatus;

Figure 4 shows an example of a method of operation of logic circuitry associated with a replaceable print apparatus component;

Figure 5 shows a schematic example of a print apparatus logic circuitry and logic circuitry associated with replaceable print apparatus components connected to a serial bus;

Figure 6 shows an example of another method of operation of logic circuitry associated with a replaceable print apparatus component;

Figure 7 shows an example of a logic circuitry package; and

Figure 8 shows an example of a replaceable print apparatus component comprising a logic circuitry package.

**DETAILED DESCRIPTION**

**[0007]** Some examples of applications of I2C communications are described herein in the context of print apparatus.

**[0008]** In some examples, logic circuitry within a print apparatus may receive information from logic circuitry associated with a replaceable print apparatus component via a communications interface, and/or may send commands to the replaceable print apparatus component. Example print apparatuses include two-dimensional imaging apparatus and three-dimensional additive manufacturing apparatus such as inkjet printers, dry toner printers, liquid toner printers, 3D powder bed inkjet printers, etc. Example print apparatus components include ink tanks; ink bottles; printheads; inkjet printhead cartridges; dry toner reservoirs; dry toner cartridges; photoconductor cartridges; process cartridges; liquid toner reservoirs; three-dimensional

printing agents including inks, stimulating agents, adhesives, inhibitors, etc.; three-dimensional printing build material; print apparatus service components; and/or any other component that may be replaceable with respect to a host print apparatus and may or may not contain print material. In this disclosure, print material or print agent may include ink, dry or liquid toner, three-dimensional printing agents, three-dimensional build material (plastics, metal, etc.), fibers, etc. The reservoirs mentioned above may contain a colored print material.

**[0009]** Communications between print apparatus and replaceable print apparatus components installed in the apparatus may provide various functions. For example, the identity, functionality and/or status of a replaceable print apparatus component and/or the logic circuitry associated therewith may be communicated to logic circuitry of a print apparatus via a communications interface. For example, a logic circuit associated with (or provided on or in) a print agent container may communicate an identity such as a product serial number and/or a brand, and/or identifying characteristics such as color, color map, color map reconstruction recipe, maximum print agent volume, or functionality to a print apparatus in which it is installed, see for example international patent application publication Nos. WO2016028272 WO2018/009235 or WO2015016860 or European patent publication No. EP0941856. A status, such as a fill level, may be provided via a communications interface, for example such that a print apparatus may generate an indication of the fill level to a user. In some examples, a validation process may be carried out by a print apparatus. For example, the print apparatus may verify that a replaceable print apparatus component originates from an authorized source, so as to ensure the quality thereof. For example, logic circuitry associated with a replaceable print apparatus component may store secret keys and may be configured to generate session keys, session key identifiers and/or message authentication codes for generating authenticated cryptographic responses to the printer, see for example US patent No. 9619663. The logic may also include further authentication mechanisms such as dedicated hardware for calculating responses within predefined, relatively short, time windows, see for example US patent No. 9561662. In some examples, the validation process may include an integrity check to ensure that the replaceable print apparatus component and/or the logic circuitry associated therewith is functioning as expected.

**[0010]** In turn, instructions to perform tasks may be sent to logic circuitry of a print apparatus component from logic circuitry associated with a print apparatus via the communications interface. For example, these may include instructions to perform an authentication or encryption function, a print material level sensing function, printing tasks, or other tasks.

**[0011]** In at least some of the examples described below, a logic circuitry package is described. The logic circuitry package may be associated with a replaceable print apparatus component, for example being affixed thereto, or arranged at least partially within the housing thereof, and is adapted to communicate data with a print apparatus controller via a bus provided as part of the print apparatus.

**[0012]** A 'logic circuitry package' as the term is used herein refers to one or more logic circuits that may be interconnected or communicatively linked to each other. Where more than one

logic circuit is provided, these may be encapsulated as a single unit, or may be separately encapsulated, or not encapsulated, or some combination thereof. Each package may be configured to communicate via a serial bus interface.

**[0013]** In some examples, each logic circuitry package is provided with at least one processor and memory. In one example the logic circuitry package may be, or may function as, a microcontroller or secure microcontroller. In use, the logic circuitry package may be adhered to or integrated with the replaceable print apparatus component.

**[0014]** In some examples, the logic circuitry package may respond to various types of requests (or commands) from a host (e.g. a print apparatus). A request may comprise a request for data, for example identification and/or authentication information (for example, a 'read' request). In other examples, a request may comprise a 'write' request. Another request from a host may be a request to perform an action, such as performing at least one measurement or carrying out a printing task or the like. Another type of request may be a request for a data processing action.

**[0015]** In an example of an interaction, a host may send a command to a logic circuitry package associated with a replaceable print apparatus component, which may perform the command and load resulting data into a memory (in some examples, into a buffer and/or a specific register of a memory). A host may send a further command to read the response, whereby the response is transmitted as serial data over a connected bus. Such a process could be used, for example, to acquire data held in a memory of the logic circuitry package. For example, the first request may be a request for an identifier of that package, and may result in the package loading the identifier into a memory buffer. A subsequent 'read' request may result in the data being read out of the buffer and transmitted as a serial data signal.

**[0016]** In at least some examples, a plurality of such logic circuitry packages (each of which may be associated with a different replaceable print apparatus component) may be connected to an I2C bus.

**[0017]** Figure 1 is an example of a printing system 100. The printing system 100 comprises a print apparatus 102 in communication with a replaceable print apparatus component 104 via a communications link 106. Although for clarity, the replaceable print apparatus component 104 is shown as external to the print apparatus 102, in some examples, the replaceable print apparatus component 104 may be housed within the print apparatus. The print apparatus 102 may be any type of 2D print apparatus or 3D print apparatus.

**[0018]** The replaceable print apparatus component 104 may for example contain a consumable resource of the print apparatus 102, or a component which is likely to have a lifespan which is less (in some examples, considerably less) than that of the print apparatus 102. For example, the print apparatus component 104 may physically store ink, toner, 3D print agent or 3D print build powder and may be intended to be replaced after substantial exhaustion. The replaceable print apparatus component 104 may for example comprise a print

material container or cartridge (which may be a build material container for 3D printing, or a liquid print agent container for 2D or 3D printing). In some examples the replaceable print apparatus component 104 may comprise a print head or other dispensing component. While a single replaceable print apparatus component 104 is shown in this example, in other examples, there may be a plurality of replaceable print apparatus components, for example comprising print agent containers of different colors, print heads (which may be integral to the containers), or the like.

**[0019]** In some examples, the communications link 106 may comprise a serial bus, for example an I2C capable or compatible bus (herein after, an I2C bus).

**[0020]** Figure 2 shows an example of a replaceable print apparatus component 200, which provides the replaceable print apparatus component 104 of Figure 1. The replaceable print apparatus component 200 comprises a data interface 202 integrated into a logic circuitry package 204 described in greater detail below. In use of the replaceable print apparatus component 200, the logic circuitry package 204 decodes data received via the data interface 202. The data interface 202 may comprise an I2C interface.

**[0021]** In some examples, the logic circuitry package 204 may be further configured to encode data for transmission via the data interface 202. In some examples, there may be more than one data interface 202 provided for a single component 200.

**[0022]** In some examples, the logic circuitry package 204 may be configured to act as a 'slave' in I2C communications.

**[0023]** The replaceable print apparatus component 200 in this example comprises a print material reservoir 206, which may contain any of the examples of print materials discussed above.

**[0024]** Figure 3 shows an example of a print apparatus 300. The print apparatus 300 may provide the print apparatus 102 of Figure 1. The print apparatus 300 comprises a controller 304 which comprises an interface 302 for communicating with a replaceable print apparatus component and a communications bus 306. The controller 304 comprises logic circuitry. In some examples, the interface 302 is an I2C interface and the communications bus 306 is an I2C capable communications bus.

**[0025]** In some examples, controller 304 may be configured to act as a host, or a master, in I2C communications. The controller 304 may generate and send commands to at least one replaceable print apparatus component 200, and may receive and decode responses received therefrom.

**[0026]** Such print apparatus 102, 300 and replaceable print apparatus component(s) 104, 200, and/or the logic circuitry package thereof, may be manufactured and/or sold separately. In an example, a user may acquire a print apparatus 102, 300 and retain the apparatus 102, 300 for

a number of years, whereas a plurality of replaceable print apparatus components 104, 200 may be purchased in those years, for example as print agent is used in creating a printed output. Therefore, there may be at least a degree of forwards and/or backwards compatibility between print apparatus 102, 300 and replaceable print apparatus components 104, 200.

**[0027]** Figure 4 is an example of a method which is carried out by a logic circuitry package associated with a replaceable print apparatus component. In some examples, the method may be carried out such that a print apparatus in which the replaceable print apparatus component is installed may determine the physical location of the replaceable print apparatus component. While the methods set out herein could be used with communications protocols other than I2C, such as Serial Peripheral Interface (SPI) protocol, it may be noted that in I2C protocols, a plurality of devices are connected serially on a single bus without any means of immediately determining or declaring their physical location or order. However, when considering for example SPI, there are two wiring configurations, parallel and daisy-chained. In the parallel wiring configuration, there is a separate line dedicated to each 'slave' logic circuit and in the daisy-chained configuration, the devices are wired sequentially in a specific order, so their relative position may be validated in some other way. Therefore the method set out herein may have particular utility with protocols in which it is otherwise difficult to verify a physical location of a device, such as I2C. However, it is not limited thereto.

**[0028]** Block 402 comprises receiving a first command sent to an address of logic circuitry associated with a replaceable print apparatus component via a serial data bus, for example an I2C bus. In some examples, the first command may be indicative of an operation mode. In some examples, the first command may be indicative of a time period. The address may be an I2C bus interface address, stored and/or hardwired to the logic circuitry/logic circuitry package. The first command may be sent to the address by a controller of the print apparatus. The first command may be a predetermined command.

**[0029]** Block 404 comprises generating, by the logic circuitry, a low voltage condition on the serial data bus. As is set out in greater detail below, this may comprise, effectively, providing a connection between the serial data bus (and more particularly, a data line of the serial data bus) and ground. In one example low voltage is a nominal ground or reference voltage such as approximately 0V. As will also be set out below, the low voltage is lower than a high or default voltage state or condition.

**[0030]** Block 406 comprises monitoring the duration of the low voltage condition using a timer of the logic circuitry. The timer may comprise an integral timer, internal to the logic circuitry, for example comprising a Resistance-Capacitor (RC) circuit configured to act as a timer, logic gates configured with a counter, a crystal or a ring oscillator, a phase lock loop (also known as a phase-locked loop) or the like, or any timer which logically forms part of a logic circuitry provided in association with the replaceable print apparatus component. The timer may provide an internal clock signal which is provided even in the absence of a clock signal on the serial data bus. The timer may count and thus allow for determination of the duration of the timer period specified in the first command.

**[0031]** The timer may be dedicated to measuring the time period of the command. In certain example, the timer is dedicated to measure time irrespective of other, general purpose cycles in an operating I2C logic circuitry package such as the I2C clock cycles and/or the processing cycles of a central processing unit of a host apparatus or of the logic circuitry. For example, the timer may be configured to count faster than the clock frequency and may start and stop counting irrespective of a clock signal timing. The timer can be configured to count irrespective of a processor speed of the central processing unit of the logic circuitry/host apparatus, for example having nominal specifications unrelated to the central processing unit.

**[0032]** In other examples, the logic circuitry/logic circuitry package may monitor the time period based on monitoring an external timer such as the external clock, or by monitoring external or internal wave signals, oscillating signals, etc. which in certain instances could be suitable to determine the duration of the time period. In one example, the timer of the logic circuitry package may be a timer which is wirelessly linked with the logic circuitry (and as such, one timer could be shared by more than logic circuitry).

**[0033]** The method further comprises releasing the bus, or removing the low voltage condition, at the end of a time period, for example such that the serial data bus assumes a different, high and/or default, voltage state or condition). This may for example comprise interrupting a connection to ground. Outside of the time period, e.g., before and after the duration of the time period as initiated in response to the first command, the logic circuitry/logic circuitry package may generate a high voltage condition. Alternatively, such a high voltage condition may a default condition created by including a 'pull up' resistor on the bus, as is described below.

**[0034]** To consider, for example, an I2C data bus, this comprises two communications lines: a serial data line (SDA) and a serial clock line (SCL). SDA and SCL may be bidirectional lines, connected to a positive supply voltage via a current-source or pull-up resistor.

**[0035]** Absent a signal on the line (i.e. absent a clock signal on the SCL and/or absent a data signal on the data line) both lines may be by default in a HIGH voltage state. The exact value of the voltage in the high voltage state depends on many operational factors, but in some examples may be a few volts, for example between around 3 and 6 volts. Therefore, while in general the 'high' voltage may be relatively low, this is high compared to a 'low' voltage state of the bus, which may for example be less than 1 volt.

**[0036]** The master/host device (for example in the present context, processing circuitry or a controller of a print apparatus in which the replaceable print apparatus is installed) may generate a clock signal by pulling the voltage of the SCL line down to a LOW state, for example using an open-drain configuration to, in effect, provide a short circuit to ground. For example, a switch (such as a field effect transistor) may be activated (closed) to cause a low voltage state, then reopened to allow a pull-up resistor on the line to pull the voltage up to the HIGH state. In other examples, an open-collector configuration may be used in which a Bipolar Junction Transistor (BJT) may be used for a similar effect. The timing of the pull-down and release

provides a clock signal which is controlled by the processing circuitry of the master device.

**[0037]** In order to transmit data, either the master device or the slave (in this example the logic circuitry associated with the replaceable print apparatus) may selectively control the voltage on the SDA in a similar way by pulling it LOW (e.g. providing a connection to ground) or allowing it to 'float HIGH' (e.g. interrupting the connection to ground). This is timed with the clock signal: according to the I2C protocol, the state of the SDA line when the SCL line is HIGH provides at least one data bit. Usually, if the SDA line is LOW (and stable) when the SCL is HIGH, this signifies a binary 0 and if the SDA line is HIGH (and stable) when the SCL is HIGH, this signifies a binary 1, although this is a matter of convention so could, in a given system, be changed.

**[0038]** In one example of the method of Figure 4, rather than providing a data signal which is timed to coincide with the SCL line being high, the state of the SCL line is not considered. Instead, the voltage is pulled low for a duration which is monitored by a timer of the logic circuitry (again, for example by providing a connection to ground), then 'released', or allowed to assume the default HIGH state (for example by interrupting that connection). Indeed, in some embodiments, there may be no clock signal provided by the master device for at least part, and in some examples, the whole of, the duration of the low voltage condition.

**[0039]** As mentioned above, this method may be of use in the context of detecting the physical location of replaceable print apparatus components, as is now described with reference to Figure 5. For example, this method may be of use in detecting if a replaceable print apparatus component such as a print material supply is installed in an intended position. In some examples, this may remove or reduce the use of mechanical keying', in which a replaceable print apparatus component is shaped particularly to match a 'slot' having a complementary shape. This in turn reduces manufacturing complexities, as the replaceable print apparatus components, for example of different print material types such as different colours, may have a common physical design. In some examples, a combination of mechanical keying and the techniques described herein may be used. For example, as in some applications, black (K) colorant tends to be dispensed more often than other colors (for example, in contexts where text is often to be printed), black print material supply cartridges may be physically larger than, for example, cyan, magenta or yellow print material supply cartridges in a CMYK cartridge set. Therefore, in some examples, mechanical keying (e.g. by the sheer size of the black cartridge versus the other colours) may be used for a black cartridge, which may be sufficient to ensure that the black cartridges are placed in the intended 'slot', and the techniques described herein may be used to ensure that that cartridges of other colors are placed as intended.

**[0040]** In some examples, a time period monitoring function, for example by the timer, may be used for other purposes. For example, the logic circuitry package may be configured to have more than one I2C address, for example to facilitate communication with different logic circuits or different functions comprised in the package over the same I2C bus interface of the logic circuitry package (e.g. via the same single data interconnect pad, and the same single power pad, the same single ground pad and/or the same single clock pad). For example the default

data read/write communications and low voltage generation and/or detection may be associated with a primary address of the logic circuit package, which is the earlier mentioned package address. The logic circuitry package may be adapted to be able to temporarily "switch" (i.e. respond to commands directed thereto) to a secondary, e.g., temporary, I2C address upon receiving a corresponding command. This command may include a second time period. This second time period may be monitored by the logic circuitry package, for example using the timer, to determine the time during which the logic circuitry package is to respond to commands received via the secondary address. For example, the logic circuitry may be associated with the primary address for a first time period and the secondary address for a second time period, wherein the second time period may be monitored using the timer. In this context, the first time period may be any time period outside of the second time period. In certain practical examples, this second time period may be longer than the time period for generating the low voltage condition, to facilitate sufficient time for data communication via the secondary address, which time period may be longer than, e.g., a replaceable print apparatus component installation location detection of this disclosure. Activating at least one different address may comprise setting (e.g. writing, re-writing or changing), or triggering the setting of, a different address (for example, a temporary second address), for example by writing the different address in a portion of memory which is indicative of an address of the logic circuitry package.

**[0041]** The logic circuitry may be configured to provide a first set of responses, or to operate in a first mode, in response to instructions sent to a first address and to provide a second set of responses, or to operate in a second mode, in response to instructions sent to a secondary address. In other words, the address may trigger different functions provided by the circuitry. In some examples, the first set of responses is accessible in response to commands sent to the first address and not in response to commands sent to the secondary address and the second set of responses is available in response to commands sent to the secondary address and not in response to commands sent to the first address. In some examples, the first set of first set of responses may be cryptographically authenticated (e.g. accompanied by a message authentication, or otherwise cryptographically 'signed', and/or encrypted) and the second set of responses is not cryptographically authenticated. In some examples, such as second address may be utilised to access other cells or sensors or the like, which may be provided on or otherwise associated with, the logic circuitry.

**[0042]** By multi-purposing the time period monitoring function, the times for executing these multiple tasks (e.g. location detection and secondary address communication) can be specified dependent of each print apparatus platform characteristics, for example including speed, capabilities, logic circuitry package specifications, number of potential connectable replaceable components to a single bus, bus speed, etc.

**[0043]** Figure 5 shows an example of a serial bus 500 comprising four lines in total: two active lines, SDA and SCL, as described above, a Voltage source connection Vdd and a ground connection GND. The active lines are bi-directional. The Voltage source connection Vdd is connected to first voltage source 502 and the SDA line is connected to a second voltage

source 504 via a pull-up resistor 506.

**[0044]** A master device 508, for example comprising a print apparatus controller associated with an Analogue to Digital converter 510 is attached to the bus 500. The bus 500, master device 508 and Analogue to Digital converter 510 may be provided by a print apparatus. The master device 508 comprises processing circuitry associated with (in some examples, provided within) a print apparatus. Four 'slave devices' 512a-d, which comprise logic circuitry associated with- in this example affixed to- replaceable print apparatus components 514a-d are also attached to the bus 500. In this example, each of the replaceable print apparatus components 514a-d comprises an ink cartridge of a given color.

**[0045]** In this example each slave device 512a-d attached to the bus 500 has its own unique address, and can be a receiver and/or transmitter. In typical operation, serial clock signals and serial data signals are provided from the master device 508 via the clock signal line SCL and data line SDA, while operational voltage for the slave devices is provided between the voltage source line Vdd and ground line GND. Data signals may also be sent from a slave device 512 to the master device 508.

**[0046]** In an example, a communication which begins with a START condition and ends with the STOP condition may be referred to as an I2C "packet." In an example of a I2C packet sent by the master device 508, this may contain a slave device address, an indication of whether the command is a read or write command (in some examples, these may together make up a byte), a command code (which may be a second byte of data), and, in some examples, any additional command data (for example, additional command parameters, message authentication codes (MACs), cyclic redundancy checks (CRCs), and the like, which may be one or more subsequent data bytes).

**[0047]** In an example of operation when carrying out the method of Figure 4, the master device 508 may first issue a START condition, which acts as an 'attention' signal to all of the connected slave devices 512. This may for example be characterised by a fall in voltage in the SDA line while the SCL voltage is HIGH. The master device 508 may then send a byte including the address of the slave device 512 that the master device 508 desires to access, and a bit that provides an indication of whether the access is a read or write operation.

**[0048]** After receiving the address byte, all slave devices 512a-d will compare it with their own address. If it there is no match, the slave device 512 will generally wait the next START condition that is initiated by the master device 508.

**[0049]** If, however, the address matches, the circuitry of that slave device 512a-d will receive the subsequent command information and thereafter produce an acknowledge response signal (an "ACK" signal) (which may comprise pulling the SDA line LOW in a particular clock period).

**[0050]** In some examples set out herein, the command may be a command to cause the slave device 512 to generate a low voltage condition for a time period. The low voltage condition

may be caused after generation of the ACK response signal. The master device 508 may then generate a STOP condition.

**[0051]** Once the master device 508 receives the acknowledge signal, (and in some examples after generation of a STOP condition), the master device 508 may seek to confirm that the slave device 512 has generated a LOW voltage condition on the SDA (and, in some examples, may cease sending the clock signal on the SCL while this LOW voltage condition is expected).

**[0052]** In this example, a resistive voltage divider network is provided in the SDA of the serial bus 500 to allow electronic determination of the respective physical positions of the slave devices 512. Specifically, a series of divider resistors 516a-d are provided on the data line SDA, and there is a connection 518 from the data line SDA to the analog-to-digital converter (ADC) 510. This configuration creates a ladder divider network (or ladder resistor network) that causes the voltage of a signal from each device 512 to vary depending upon the physical position of the device 512, as the devices 512 connect to the divider network at different points. For example, a signal from slave device 512d will pass through four of the divider resistors 516, while a signal from slave device 512a will pass through only one of the divider resistors 516a. By detecting the voltage value, the position of the slave device 512 creating the low voltage condition may be determined. In other words, each slave device 512 creates a different low voltage condition. The voltage may be detected using the ADC 510. The ADC 510 includes circuitry that converts an analog voltage into a digital signal indicative of the voltage level. This digital signal is used by the master device 508 to electronically differentiate the physical location of the slave devices 512 on the bus based upon the voltage level of signals from the slave devices 512. The voltage may be compared to an expected voltage for a device 512 having the addressed used in the command.

**[0053]** The ADC 510 may receive control signals from and provides data to the master device 508 via a communication link (which can be another communication bus). While the ADC 510 is shown separately from the master device 508, the ADC 510 can be part of the master device 508 physically, or it can be in a separate location.

**[0054]** The ADC 510 and the ladder divider network may be configured to operate to allow differentiating location by detecting the voltage order of the devices on the bus 500, without interfering with the identification of HIGH and LOW states used in data transfer. In other words, all the characteristic low voltages produced on the bus by each slave device 512 may be relatively distant from the threshold for characterising each data bit as being HIGH or LOW.

**[0055]** To consider one example, the master device 508 can be configured to detect any signal below a threshold value to be a LOW voltage condition when receiving data. For example, any voltage below 2V, or below 1V, when a SCL voltage is HIGH may be identified as a LOW data bit (in some examples, a 0), whereas values above this threshold may be identified as a HIGH data bit (in some examples, a 1). In some examples, the threshold for detecting a LOW data bit is a voltage below 1.3 V.

**[0056]** However, the master device 508, using the converted voltage from the ADC 510, can be configured to distinguish between specific signals that are below this threshold and some amount above zero (or nominally 0V) (e.g. up to around a few hundred millivolts (mv)) to allow positional identification. Each divider resistor 516 may have a resistance sufficient so that the voltage created between the sum of the divider resistors 516 and the pull-up resistor 504 is a voltage below the LOW voltage threshold. However, the resistance of the divider resistors 516 may be selected to be small enough that identification of HIGH voltage signals from the master device 508 during normal operation is not unduly compromised- i.e. the HIGH voltage remains relatively close to the maximum voltage provided by the second voltage source 504.

**[0057]** In one embodiment, the divider resistors 516 each have a resistance of about 51 ohm, though this is only one of many resistance levels that can be used, and the resistance levels may vary between the different resistors 516. In such an example, the first and second voltage sources 502, 504 may each provide around 3.3 volts and the pull-up resistor 506 may be a resistor of around 1000 ohm (1Kohm), i.e. significantly larger resistance value than the divider resistors 516.

**[0058]** In other words, the divider resistors 516 could act as individual 'additional' pull up resistors on the SDA line, preventing it from falling to a nominal 0V. This may provide, for example a voltage difference of around 100-200mV given the values specified above. This may be measured in terms of 'counts' by the ADC 510. For example, in a 3.3V system, where a 9-bit ADC is provided, this in turn means each count represents around 6mV (which is determined by dividing 3.3V by 512). Therefore, the ADC 510 may be expected to register around 20 counts for the lowest voltage cartridge to around 80 counts for the highest voltage.

**[0059]** As noted above, it may be the case that at least some replaceable print apparatus components may have their position verified using mechanical keying rather than the methods set out herein. Therefore the number of voltage levels detected may be less than the number of, for example, print supply cartridges used.

**[0060]** It may be noted that, as there are particular addresses associated with the replaceable print apparatus components 514a-d, a specific command may be sent to, say 514a, the voltage sampled and then the process repeated for each of the replaceable print apparatus components 514b, c and d in turn. If the replaceable print apparatus components 514a-d are in their expected locations, there may be expected to be a progressive change in the voltage value from lower to higher if measured in that order. However, if the replaceable print apparatus components 514a-d are not in the expected locations, this pattern (or more generally, the expected relative voltages) will not be seen and a warning may be generated.

**[0061]** In practise, the time period for which the SDA line is held low may exceed a sampling time period. For example, a slave device 512 may be commanded by the master device 508 to hold the SDA line low for 50ms. During this time, the data line SDA may be sampled a certain number of times-for example, between 3 and 10 times - by the ADC 510 of the host apparatus. In some examples, if at least one of these readings is not within a certain threshold range, the

command may be run again and new samples may be acquired. In other examples, samples may be taken until there is a threshold number of 'good' samples. In some such examples, there may be a maximum number of samples permitted before an error state is declared- for example, samples will continue until 5 samples have been acquired which are within an expected range or a maximum of 10 samples have been taken. If no 'good' set of samples is acquired, an error may be indicated. The samples may be averaged to generate a representative value for that replaceable print apparatus component 514a-d.

**[0062]** The sampling period may be relatively short. For example, after the slave device 512 has been commanded to hold the SDA line low, the master device 508 may wait before sampling the bus to allow the bus to settle (for example, for around 10ms). Acquisition of samples may take place within around 1ms. However, the SDA line may be held low for a longer period, for example 50ms, to allow for retesting or the like. This period may be specified in, or in some examples associated with (for example by reference to a lookup table or register held in the slave device 512) the first command.

**[0063]** Therefore, it need not be the case that the SDA line is held low for the entirety of a time period specified by or in the first command, where applicable. However, it may be the case that, at least statistically, the slave device 512 is to hold the SDA line low such that the sampling period is likely to occur during the time for which the SDA line is held low, on at least one of a permissible set of trials.

**[0064]** It will be appreciated that the SDA line could be held low by, in effect, sending a data signal made of a succession of data bits associated with a low voltage state (for example, a succession of 0 bits). This will result in the SDA line being held low for a time period. However, when sending a data signal, the slave device 512 may refer to the signal on the SCL, rather than its own internal timer, to determine when to release the SDA line to allow it to return to a HIGH state (i.e. when to remove the low voltage condition, such that the serial data bus assumes a different, high and/or default, voltage state or condition). However, in the methods set out herein, the low voltage condition applied following the first command is applied independently of any clock signal on the SCL bus (and in some cases in the absence of any such clock signal on the SCL bus).

**[0065]** Figure 6 shows another example of a method of operation of logic circuitry (in this example, the logic circuitry package 204 as described above) associated with a replaceable print apparatus component. In this example, in block 602, the logic circuitry receives, via an I2C data bus, a first command which specifies a first time period. In this example, the first command also comprises an indication of START condition, an address of a logic circuitry package, an identification field indicative of a write command and an indication of a stop condition (for example, a rising voltage on a data line during a HIGH portion of a clock pulse).

**[0066]** In some examples, the time period may be selected based on attributes of the host device, or the circuitry thereof. In general, a time period may be sufficiently long to allow good samples to be captured, but not so long as to unduly lengthen the time taken to verify a

position of the replaceable print apparatus component.

**[0067]** Block 604 comprises generating, by the logic circuitry, a low voltage condition on a serial data line of an I2C bus following receipt of the indication of the STOP condition (which itself follows the transmission of the command) and for substantially the duration of the first time period. As noted above, while in some examples, the low voltage condition may be generated for the whole of the time period, in some examples, the method may comprise allowing the serial data line to 'float high' during part of the first time period, i.e. the line may be held low in an interrupted fashion. In some examples, the serial data line may be held low for at least 60% of the first time period, or at least 70% of the first time period, or at least 80% of the first time period, or at least 90% of the first time period, or at least 95% of the first time period. In some examples, the voltage is held low for a sufficient proportion to reliably coincide with a sampling period. The duration of the low voltage condition comprises at least one sampling period, wherein the sampling is carried out by processing circuitry of a print apparatus, as has been described above. In addition, if the data line is held low for an unduly long time period this blocks communications and may for example cause a host apparatus to generate a timeout error or the like.

**[0068]** Generating the low voltage condition following receipt of the STOP condition indication means that the bus will not be blocked during on-going transmission of a data packet.

**[0069]** In this example, generating the low voltage condition coincides with a state in which there is no clock signal on the serial data bus, and block 606 comprises monitoring the duration of the low voltage condition using an integral timer of the logic circuitry.

**[0070]** The method further comprises, in block 608, in response to a read request having an identification field indicative of a read mode, performing, by the logic circuitry a read operation. In other words, in addition to the special features described herein, the logic circuitry may function as an I2C slave device. The logic circuitry may exhibit other features of an I2C slave device, for example taking part in authentication and/or validation exchanges, receiving or acting on read and/or write commands, undertaking processing tasks and the like.

**[0071]** Figure 7 is an example of a logic circuitry package 700 of a replaceable print apparatus component comprising logic 702, a serial data bus interface 704, a timer 706 and, in this example, a memory 708. In use of the logic circuitry package 700, the logic 702, in response to a first command sent to the logic circuitry package 700 via a serial data bus connected to the serial data bus interface 704, the logic circuitry package 700 in this example is configured to generate a low voltage condition on the serial data bus and monitors the duration of the time period using the timer 706. In some examples, the timer 706 may be in communication with the logic 702, for example via a wired or wireless link. In some examples, the timer 706 may be provided on a common substrate with the logic 702.

**[0072]** In examples herein, the logic 702 is configured to monitor the duration of the time period without reference to a clock signal of the serial data bus. The serial data bus interface

704 may comprise an I2C data bus interface.

**[0073]** The first command may specify a time period, and the logic 702 may be configured to generate a low voltage condition on the serial data bus for substantially the duration of the first time period. The logic 702 may carry out any aspects of the methods described in relation to Figures 4 to 6 above.

**[0074]** In response to a second command, the logic 702 may be configured to write data received via the serial data bus interface 704 to the memory 708. In response to a read request, the logic 702 may be configured to read data from the memory 708 and to transmit a data signal via the serial data bus interface 704.

**[0075]** Figure 8 shows an example of replaceable print apparatus component comprising a logic circuitry package as shown in Figure 7. In this example, the replaceable print apparatus component is a print cartridge 800 having a housing 802 that has a width less than its height. A print liquid output 804 (in this example, an outlet provided on the underside of the cartridge 800), air input 806 and recess 808 are provided in a front face of the cartridge 800. The recess 808 extends across the top of the cartridge 800 and I2C bus contacts 810 of a logic circuitry package 812 (for example, a logic circuitry package 700 as described above) are provided at a side of the recess 808 against the inner wall of the sidewall of the housing 802 adjacent the top and front of the housing 802. In this example, the logic circuitry package 812 is provided against the inner side of the sidewall.

**[0076]** Examples in the present disclosure can be provided as methods, systems or machine readable instructions, such as any combination of software, hardware, firmware or the like. Such machine readable instructions may be included on a machine readable storage medium (including but is not limited to disc storage, CD-ROM, optical storage, etc.) having machine readable program codes therein or thereon.

**[0077]** The machine readable instructions may, for example, be executed by a general purpose computer, a special purpose computer, an embedded processor or processors of other programmable data processing devices to realize the functions described in the description and diagrams. In particular, a processor or processing circuitry may execute the machine readable instructions. Thus functional modules of the apparatus and devices (for example, logic circuitry and/or controllers) may be implemented by a processor executing machine readable instructions stored in a memory, or a processor operating in accordance with instructions embedded in logic circuitry. The term 'processor' is to be interpreted broadly to include a CPU, processing unit, ASIC, logic unit, or programmable gate array etc. The methods and functional modules may all be performed by a single processor or divided amongst several processors.

**[0078]** Such machine readable instructions may also be stored in a machine readable storage (e.g. a tangible machine readable medium) that can guide the computer or other programmable data processing devices to operate in a specific mode.

[0079] Such machine readable instructions may also be loaded onto a computer or other programmable data processing devices, so that the computer or other programmable data processing devices perform a series of operations to produce computer-implemented processing, thus the instructions executed on the computer or other programmable devices realize functions specified by block(s) in the flow charts and/or in the block diagrams.

[0080] Further, the teachings herein may be implemented in the form of a computer software product, the computer software product being stored in a storage medium and comprising a plurality of instructions for making a computer device implement the methods recited in the examples of the present disclosure.

## REFERENCES CITED IN THE DESCRIPTION

### Cited references

This list of references cited by the applicant is for the reader's convenience only. It does not form part of the European patent document. Even though great care has been taken in compiling the references, errors or omissions cannot be excluded and the EPO disclaims all liability in this regard.

### Patent documents cited in the description

- [US20110029705A](#) [0004]
- [US9582443B](#) [0004]
- [WO2016028272A](#) [0009]
- [WO2018009235A](#) [0009]
- [WO2015016860A](#) [0009]
- [EP0941856A](#) [0009]
- [US9619663B](#) [0009]
- [US9561662B](#) [0009]

**Patentkrav**

1. Udskiftelig printapparatkomponent (104, 200, 514a-d), der omfatter en logikkredsløbspakke (204, 700, 812), hvor den udskiftelige printapparatkomponent (104, 200, 514a-d) kan udskiftes i forhold til et host-printapparat (102, 300) og omfatter et printmaterialereservoir (206), hvilken
- 5 logikkredsløbspakke omfatter:
- logik (702) og en seriel databusgrænseflade (704),  
hvor den serielle databusgrænseflade (704) skal danne grænseflade med en seriel databus (500) i et printapparat (102, 300), og
- kendetegnet ved, at** logikken (702):
- 10 som reaktion på en kommando, der sendes til logikkredsløbspakken (204, 700, 812) via den serielle databus (500), som er forbundet med den serielle databusgrænseflade (704), skal
- generere en lavspændingstilstand på den serielle databus (500) og monitorere en varighed af et tidsrum uden reference til et taktsignal for den serielle databus; og
- 15 fjerne lavspændingstilstanden på den serielle databus (500) ved tidsrummets udløb.
2. Udskiftelig printapparatkomponent (104, 200, 514a-d) ifølge krav 1, hvor logikkredsløbspakken (204, 700, 812) yderligere omfatter en timer (706), hvor logikken (702) skal monitorere tidsrummets varighed under anvendelse af timeren (706).
- 20
3. Udskiftelig printapparatkomponent ifølge krav 2, hvor timeren er konfigureret til at tælle hurtigere end taktsekvensen og kan starte og stoppe med at tælle uanset en taktsignaltidsberegning.
- 25
4. Udskiftelig printapparatkomponent (104, 200, 514a-d) ifølge et hvilket som helst foregående krav, hvor logikken (702) skal generere lavspændingstilstanden på en seriel datalinje i den serielle databus (500).
- 30
5. Udskiftelig printapparatkomponent (104, 200, 514a-d) ifølge et hvilket som helst foregående krav, hvor logikken (702) er konfigureret til, uden for tidsrummet, at få den serielle databus (500) til at antage en afvigende, høj og/eller standardmæssig spændingstilstand eller -status.

6. Udskiftelig printapparatkomponent (104, 200, 514a-d) ifølge et hvilket som helst foregående krav, hvor logikken (702) skal generere et bekræftelsessvar efter modtagelse af kommandoen inden generering af lavspændingstilstanden.
- 5 7. Udskiftelig printapparatkomponent (104, 200, 514a-d) ifølge et hvilket som helst foregående krav, hvor kommandoen specificerer et tidsrum, og logikken (702) skal generere en lavspændingstilstand på den serielle databus (500) inden for tidsrummets varighed.
- 10 8. Udskiftelig printapparatkomponent (104, 200, 514a-d) ifølge krav 7, hvor logikken (702) er konfigureret til at generere lavspændingstilstanden i det tidsrum, der er specificeret i kommandoen.
- 15 9. Udskiftelig printapparatkomponent (104, 200, 514a-d) ifølge et hvilket som helst foregående krav, hvor kommandoen specificerer et tidsrum, og logikken (702) skal generere en lavspændingstilstand på den serielle databus (500) i, i det væsentlige, tidsrummets varighed.
- 20 10. Udskiftelig printapparatkomponent (104, 200, 514a-d) ifølge et hvilket som helst foregående krav, hvor logikkredsløbspakken (204, 700, 812) yderligere omfatter en hukommelse (708), hvor
- i. kommandoen omfatter en første kommando, og som reaktion på en anden kommando skal logikken (702) skrive data, der modtages via den serielle databusgrænseflade (704), til hukommelsen (708); og/eller
  - ii. som reaktion på en læseanmodning skal logikken (702) læse data fra hukommelsen (708) og overføre et datasignal via den serielle databusgrænseflade (704).
- 25
11. Udskiftelig printapparatkomponent (104, 200, 514a-d) ifølge et hvilket som helst foregående krav, hvor den serielle databusgrænseflade (704) er en I2C-databusgrænseflade (302).
- 30 12. Udskiftelig printapparatkomponent (104, 200, 514a-d) ifølge et hvilket som helst foregående krav, hvor logikkredsløbspakken (204, 700, 812) er konfigureret til at:
- kommunikere via mere end én I2C-adresse over den samme I2C-busgrænseflade (302), modtage en kommando, der er associeret med temporær anvendelse af en afvigende, sekundær I2C-adresse, idet kommandoen indbefatter et andet tidsrum,

monitorere det andet tidsrum og reagere på kommandoer, der rettes til den sekundære 12C-adresse i løbet af det andet tidsrum.

- 5 **13.** Udskiftelig printapparatkomponent ifølge et hvilket som helst foregående krav, der omfatter en udskiftelig printapparatpatron (800) til forbindelse med et printapparat (102, 300), hvor reservoiret indeholder et farvet printmateriale, og hvor kommandoen er en kommando til bestemmelse af en lokalitet af den udskiftelige printapparatpatron, når den er forbundet med printapparatet.

# DRAWINGS

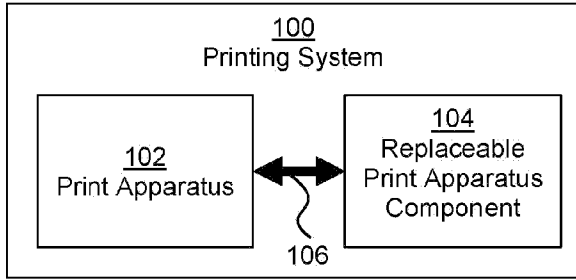

Fig. 1

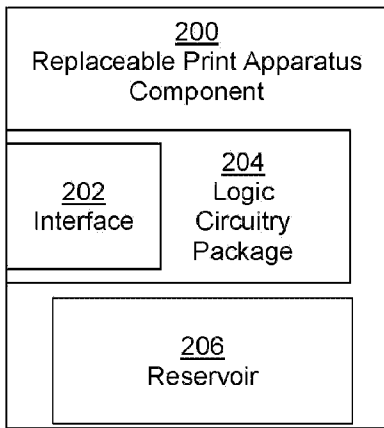

Fig. 2

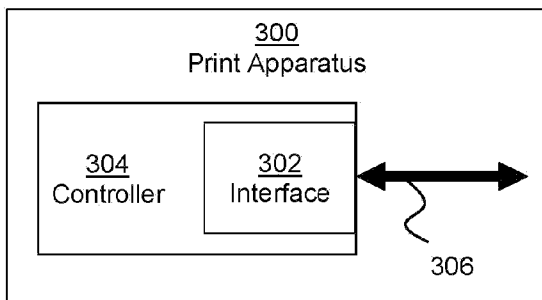

Fig. 3

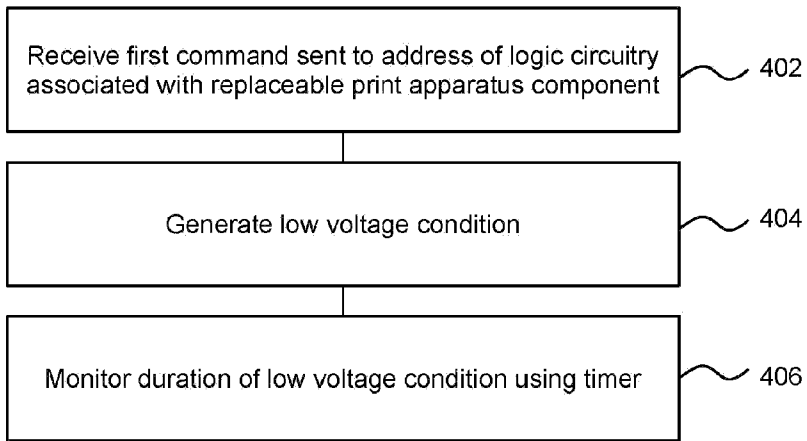

Fig. 4

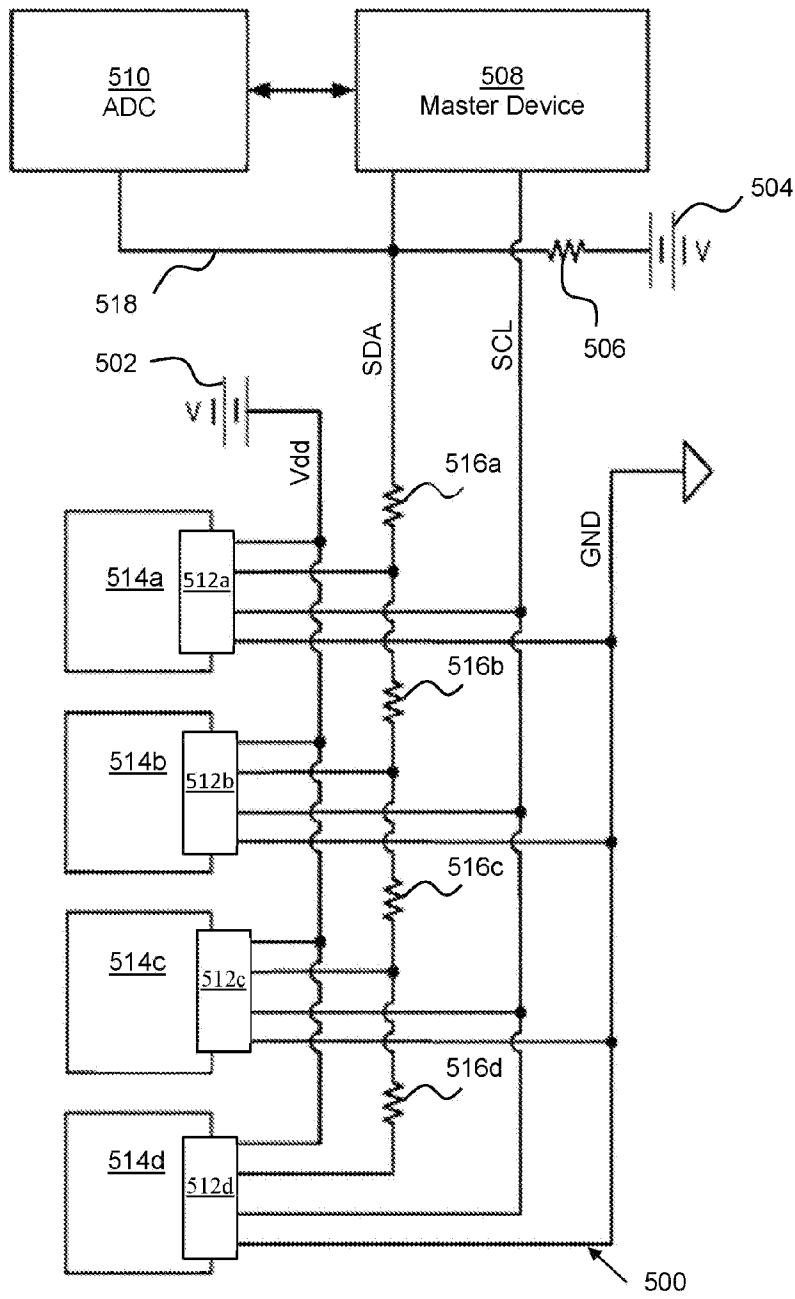

Fig. 5

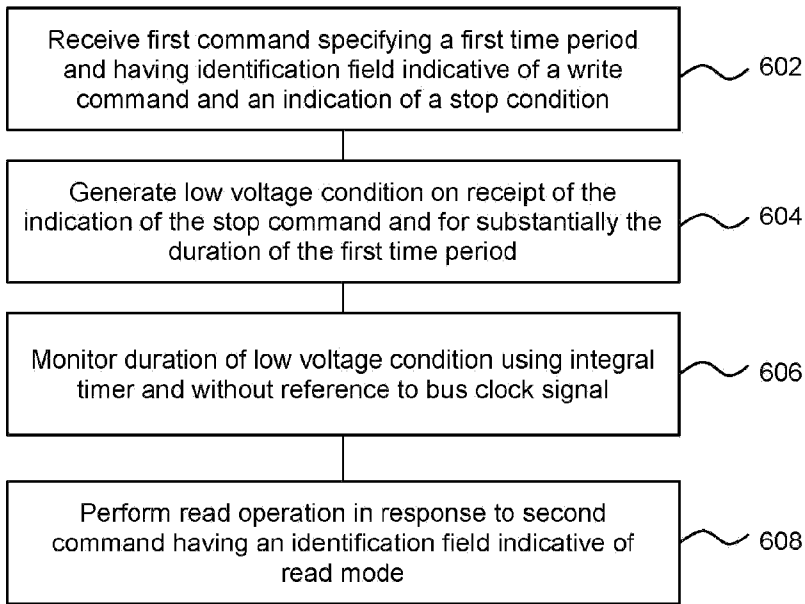

Fig. 6

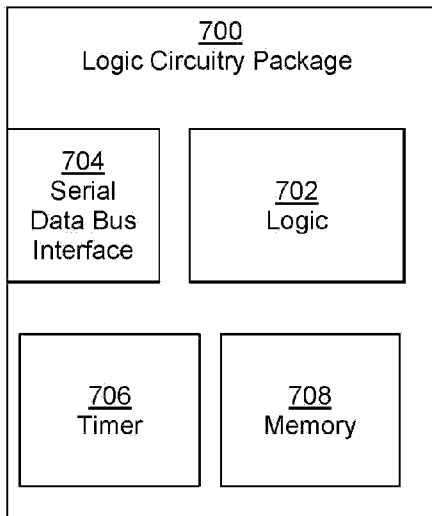

Fig. 7

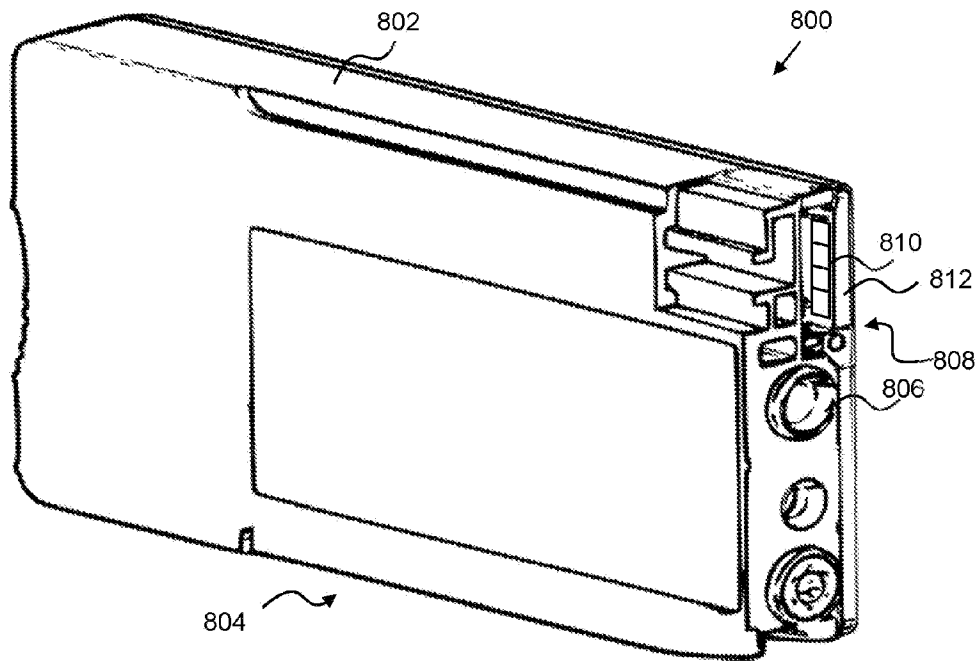

Fig. 8