

G. T. STOCKTON.  
 INSOLE CUTTER AND PASTER.  
 APPLICATION FILED OCT. 15, 1910.

996,734.

Patented July 4, 1911.

2 SHEETS—SHEET 1.

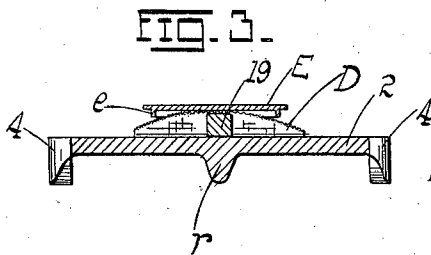
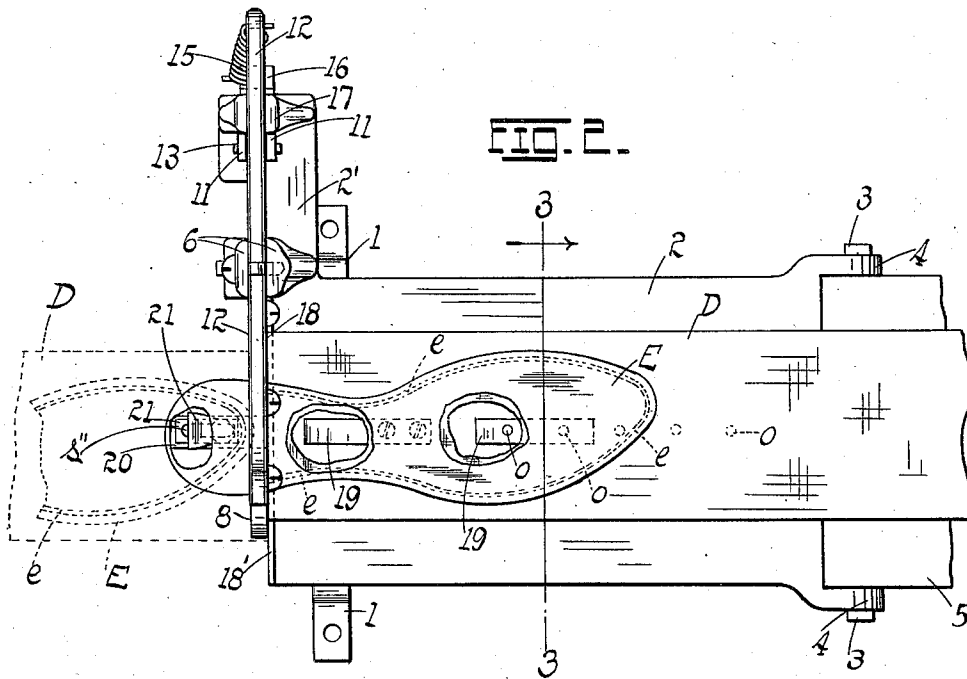
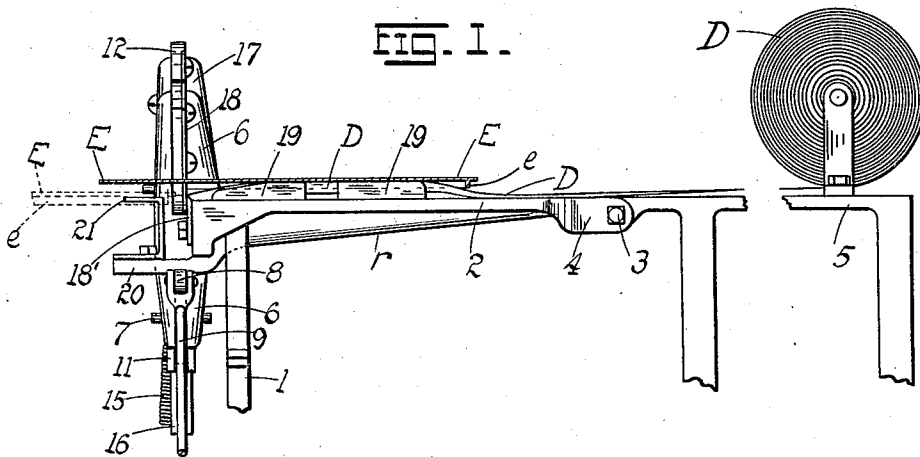

WITNESSES:  
*Harry A. Bennett*  
*A. W. Powell*

INVENTOR.  
 Geo. T. Stockton.  
 BY *Emmett H. ...*  
 ATTORNEY.

G. T. STOCKTON.  
 INSOLE CUTTER AND PASTER.  
 APPLICATION FILED OCT. 15, 1910.

996,734.

Patented July 4, 1911.

2 SHEETS—SHEET 2.

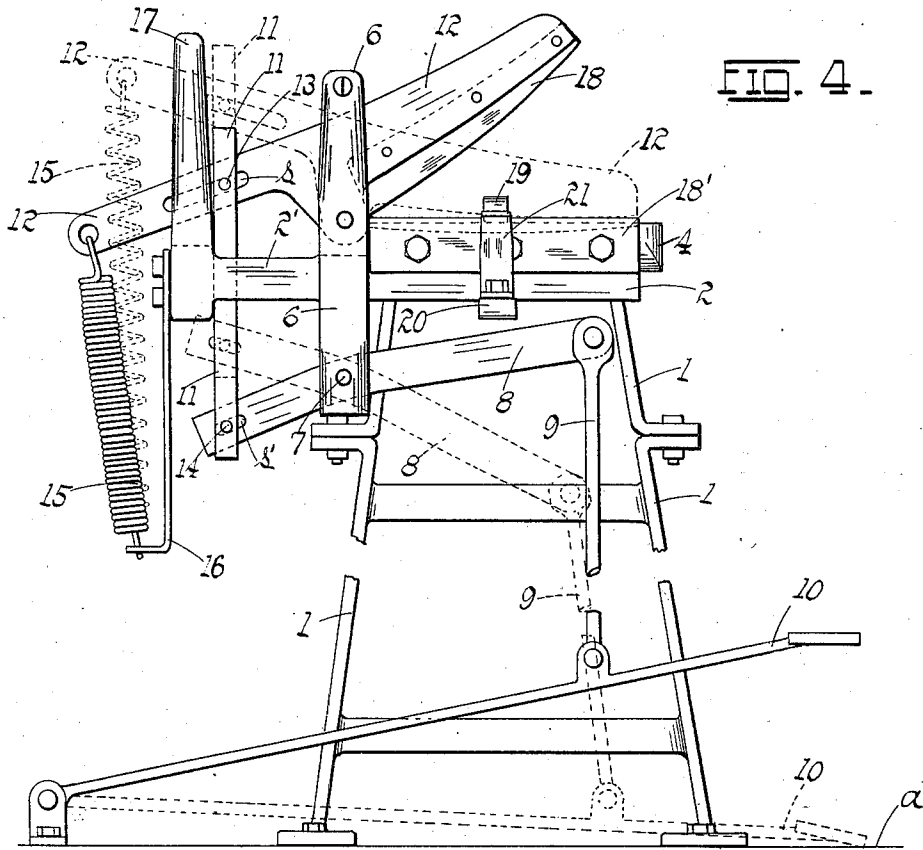

FIG. 4.

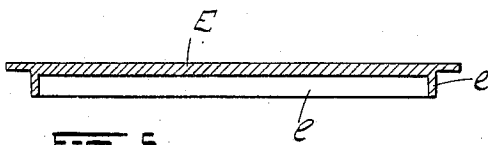

FIG. 5.

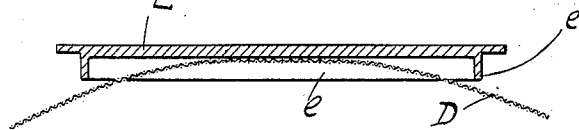

FIG. 6.

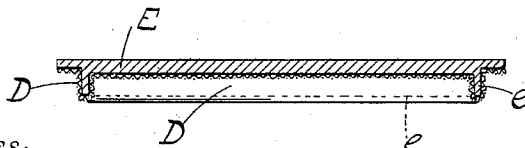

FIG. 7.

WITNESSES:

*Harry A. Berner*  
*A. W. Bell*

INVENTOR.

Geo. T. Stockton.

BY

*Emil Storer*  
 ATTORNEY.

# UNITED STATES PATENT OFFICE.

GEORGE T. STOCKTON, OF ST. LOUIS, MISSOURI, ASSIGNOR OF ONE-THIRD TO GEORGE A. SHIPLEY, OF ST. LOUIS, MISSOURI.

## INSOLE CUTTER AND PASTER.

996,734.

Specification of Letters Patent.

Patented July 4, 1911.

Application filed October 15, 1910. Serial No. 587,305.

*To all whom it may concern:*

Be it known that I, GEORGE T. STOCKTON, a citizen of the United States, residing at St. Louis, State of Missouri, have invented certain new and useful Improvements in Insole Cutters and Pasters, of which the following is a full, clear, and exact description, reference being had to the accompanying drawings, forming a part hereof.

My invention has relation to improvements in insole cutters and pasters; and it consists in the novel details of construction more fully set forth in the specification and pointed out in the claims.

In the drawings, Figure 1 is a side elevation of the machine; Fig. 2 is a top plan on a somewhat larger scale; Fig. 3 is a vertical cross-section on the line 3-3 of Fig. 2 taken through the bed-plate; Fig. 4 is an end elevation (broken in the middle); Fig. 5 is a cross-section of an insole; Fig. 6 is a cross-section of an insole with the layer of duck in proper position to be applied thereto; and Fig. 7 is a similar section with the duck-layer creased over the insole channel-lip or flange to which the welt is secured.

The present invention finds application at that stage in the manufacture of shoe insoles, where the reinforcing layer of duck (canvas or equivalent material) through which are passed the stitches which secure the welt, is pasted to the insole proper.

The object of the invention is to provide means for facilitating the pasting of the duck layer to the sole, and at the same time prevent its adhesion to the "channel-lip" or flange formed on the insole over which the duck is folded and clenched (or beaten) by the insole machine preparatory to sewing on the welt.

A further object is to so paste the duck to the insole without disturbing the channel-lip, which must always be raised above the face of the insole, or assume as nearly as possible a direction at right angles to the insole face, in order that the insole machine may successfully fold and crease the duck over the channel-lip, preparatory to sewing on the welt.

The advantages of the invention will be fully apparent from a detailed description thereof which is as follows:—

Referring to the drawings, 1 represents a standard for supporting one end of the bed-plate 2 of the machine, the opposite end of the

bed-plate being secured by means of screws 3, 3, passed through the lugs 4, 4, to a platform 5 over which is rotatably mounted a roll of duck D constituting the bottom reinforcing layer for the insole E, the said layer being first pasted along the bottom face of the insole for a distance corresponding to the length of the "channel-lip" or flange *e* formed on the insole, and then creased and beaten around the channel-lip (Fig. 7) by the insole machine (not shown) thereby properly reinforcing the channel-lip to receive the stitching by which the welt is secured to the channel-lip. These features are of course, well known and are merely alluded to so that a clearer understanding may be had of the invention proper.

Cast with the bed-plate 2 at the discharge end of the machine is a terminally forked member or arm 6, the bottom fork members receiving the pivotal pin 7 of an oscillating lever 8 to the outer end of whose long arm is pivotally coupled the upper end of a link 9, the lower end thereof being pivotally secured to a pedal-lever 10 hinged to the floor *a*. The end of the short arm of the lever 8 is loosely coupled to a vertically reciprocating bar 11 operating freely through a bracket arm 2' cast with the bed-plate, the upper end of said bar being connected to an oscillating blade-carrier lever 12, in a manner to allow for the oscillation of the blade with a reciprocation of the bar. The connection is by means of a pin 13 traversing a slot *s* in the rear arm of the lever 12, the bar being forked to receive said arm. It may be stated in passing that the lower end of the bar 11 is likewise forked to receive the short arm of the lever 8, a pin 14 traversing the slot *s'* formed in said lever-arm. The free end of the rear-arm of the lever 12 is coupled to one end of a retracting spring 15, the opposite end of the spring being secured to a depending bracket 16 bolted to the arm 2', at the base of the forked guide-member 17 by which the blade-arm is guided in its oscillations. Coöperating with the blade 18 of the lever 12 is a stationary complementary blade 18' bolted to the end of the bed-plate 2.

It will be seen from the foregoing that a depression of the pedal-lever 10 will result in an upward oscillation of the rear arm of the blade-lever 12, and a consequent depression of the blade 18 to coöperate with

the blade 18', the spring 15 returning the parts to their original position upon release of the pedal 10. These features however, are all within the skill of the mechanic and are not claimed herein, except as they may enter as elements of the combinations forming the subject-matter of the present invention.

Mounted to the bed-plate 2 and substantially in the path of the central line of the sheet unwound from the roll D, are blocks 19 which form a ridge or hump from which the sides of the sheet D will necessarily droop more or less as the sheet is passing over the blocks. This drooping prevents the duck sheet from engaging the often sensitive and pliable channel-lip *e* of the insole E laid on the gummed face of the sheet to effect adhesion thereto, thus leaving the channel-lip undisturbed (Fig. 6) to be delivered to the insole machine by which the creasing or folding of the duck over the channel-lip is accomplished (Fig. 7). Bolted to a bracket 20 forming the extension of a reinforcing rib *r* on the bed-plate is a U-shaped gage 21, one arm of which is secured adjustably to said bracket (a slot *s*' being provided to permit of an adjustment to and from the blade 18'), the upper inner corner of the gage coming in contact with the toe end of the channel as the sheet D is passed or pulled across the knives, thus measurably arresting the movement of the sheet and indicating the point at which the knife 18 shall be brought down to cut off the sheet D.

The operation will now be readily understood from the foregoing description:—It will be understood of course, that the upper face of the sheet of duck unwound from the roll D is coated with an adhesive compound to which the shoe insole will well adhere as the sole is laid on the sheet. In practice, the operator pulls on the sheet and draws it over the bed-plate 2 and over the blocks 19, 19, toward the blade 18'. As the sheet is passing over the blocks 19 the operator seizes an insole E and deposits the same with the channel *e* down, on the gummed face of the sheet directly over the blocks 19, imparting a slight pressure to said insole so it may adhere to the sheet. The points or area of adhesion will be limited more or less to the surfaces of the blocks and perhaps to points on either side thereof, but not sufficiently to cause the sheet to adhere to, or disturb the channel-lip *e*, for as previously stated, the channel-lip must be intact and at right angles to the plane of the insole, when the latter is taken to the insole machine to have the duck creased over the channel-lip. The blocks or ridges 19 thus serve to raise the center of the sheet D allowing the sides of the latter to droop away from the channel-lip and thus avoid disturbing the latter (Fig. 6). That is the

function of the blocks. With the insole thus adhering to the sheet, the latter is drawn along until the toe of the channel-lip strikes or engages the corner of the member 21. Since the toe of the channel-lip is quite close to the toe of the insole proper, and since the member 21 is removed from the blade 18' a distance considerably in excess of the margin of the insole left projecting beyond the channel-lip, it follows that when the blade 18 is brought down on the sheet D, it will sever the latter a slight distance beyond the toe of the insole (Figs. 1, 2). For different lengths of insoles different lengths of blocks 19 may be used, for which purpose a sufficient number of openings *o* are left in the bed 2 for the screws by which the blocks are held in place. So too, may the gage 21 be adjusted to vary the position of the point at which the sheet D is to be severed. A roll such as D usually accommodates about four hundred insoles more or less.

Having described my invention, what I claim is:—

1. In combination with a bed for the passage of sheet material, a formation raised above the surface of the bed and traversed by the medial portion of said sheet whereby the medial portion of the sheet is raised and the sides are allowed to droop.

2. In combination with a bed for the passage of sheet material, a ridge formation on the bed traversed by the medial portion of said sheet whereby the medial portion of the sheet is raised and the sides are allowed to droop, and means at the discharge end of the bed for severing the sheet into predetermined lengths.

3. In combination with a bed for the passage of sheet material, a ridge formation on the bed traversed by the medial portion of said material whereby the medial portion of the sheet is raised and the sides are allowed to droop; the exposed face of the sheet being coated with adhesive for pasting the sheet to an insole provided with a marginal channel-lip facing the sheet, a movable knife mounted across the path of travel of the sheet, and a gage positioned beyond the knife and engaging the toe end of the channel for momentarily arresting the moving sheet, and means for actuating the knife and severing the sheet, thus momentarily arrested.

4. A machine of the character described comprising a bed-plate, a block mounted over the bed over which a sheet of adhesive coated duck is adapted to be passed, said sheet drooping from the block toward the bed, whereby upon the placing of a lipped insole on the sheet the lip will be undisturbed by the gummed face of the sheet, a stationary blade at one end of the bed over which the sheet is passed, an oscillating blade cooperating with the stationary blade for

severing the sheet, and a gage mounted at a point outside the blades and engaging the toe end of the lip of the insole for measurably arresting the movement of the sheet, and determining the point at which the same is to be severed.

5. In combination with a bed over which a sheet is to be passed, a ridge positioned on the bed in the path of the medial portion of the sheet for raising the center of the sheet off the bed and allowing the sides of the sheet to droop, for the purpose set forth.

6. In a machine of the class described, a

bed, and means raised above the bed for engaging the medial portion of a sheet passed over the bed, and raising said medial portion off the bed the sides of the sheet drooping down from said medial portion, for the purpose set forth. 15

In testimony whereof I affix my signature, 20  
in presence of two witnesses.

GEORGE T. STOCKTON.

Witnesses:

EMIL STAREK,  
A. W. POWELL.

Copies of this patent may be obtained for five cents each, by addressing the "Commissioner of Patents, Washington, D. C."