

(12) PATENT
(19) AUSTRALIAN PATENT OFFICE

(11) Application No. AU 199660841 B2
(10) Patent No. 700116

(54) Title
Vortex flow meter detector and vortex flow meter

(51)⁶ International Patent Classification(s)
G01F 001/32

(21) Application No: 199660841 (22) Application Date: 1996 .08 .01

(30) Priority Data

(31) Number	(32) Date	(33) Country
7-200619	1995 .08 .07	JP
7-284802	1995 .11 .01	JP

(43) Publication Date : 1997 .02 .13
(43) Publication Journal Date : 1997 .02 .13
(44) Accepted Journal Date : 1998 .12 .24

(71) Applicant(s)
Oval Corporation

(72) Inventor(s)
Matsubara Naoki, Tanimoto Jun, Takai Kenichi, Imai Shinsuke

(74) Agent/Attorney
F B RICE CO

(56) Related Art
EP 0110321
EP 0144937
US 4854177



AU9660841

(12) PATENT ABSTRACT (11) Document No. AU-A-60841/96
(19) AUSTRALIAN PATENT OFFICE

- (54) Title
VORTEX FLOW METER DETECTOR AND VORTEX FLOW METER
- International Patent Classification(s)
(51)⁶ **G01F 001/32**
- (21) Application No. : **60841/96** (22) Application Date : **01.08.96**
- (30) Priority Data
- | | | |
|-------------|-----------|--------------|
| (31) Number | (32) Date | (33) Country |
| 7-200619 | 07.08.95 | JP JAPAN |
| 7-284802 | 01.11.95 | JP JAPAN |
- (43) Publication Date : **13.02.97**
- (71) Applicant(s)
OVAL CORPORATION
- (72) Inventor(s)
NAOKI MATSUBARA; JUN TANIMOTO; KENICHI TAKAI; SHINSUKE IMAI
- (74) Attorney or Agent
F B RICE & CO , 28A Montague Street, BALMAIN NSW 2041
- (57)

A vortex flowmeter detector is attached to or detachable from a vortex generation body under measurement of flow rate. The vortex flowmeter detector comprises a cylindrical oscillation tube having a bottom and a vortex detection part which is fixed by a fixing flange of the oscillation tube, wherein the oscillation tube is detachably inserted into a hole which is open to the vortex generation body, not shown, at one end thereof, and the oscillation tube is fixed by a flange. An alternate pressure caused by a Karman vortex is introduced from both sides of the vortex generation body into the hole so as to oscillate the oscillation tube. This oscillation is received by a spring plate by way of an element cover, and it is transmitted to piezoelectric elements which are stuck to two chamfers of an elastic base material.

ABSTRACT

A vortex flowmeter detector is attached to or detachable from a vortex generation body under measurement of flow rate. The vortex flowmeter detector comprises a cylindrical oscillation tube having a bottom and a vortex detection part which is fixed by a fixing flange of the oscillation tube, wherein the oscillation tube is detachably inserted into a hole which is open to the vortex generation body, not shown, at one end thereof, and the oscillation tube is fixed by a flange. An alternate pressure caused by a Karman vortex is introduced from both sides of the vortex generation body into the hole so as to oscillate the oscillation tube. This oscillation is received by a spring plate by way of an element cover, and it is transmitted to piezoelectric elements which are stuck to two chamfers of an elastic base material.



AUSTRALIA

Patents Act 1990

OVAL CORPORATION

ORIGINAL

**COMPLETE SPECIFICATION
STANDARD PATENT**

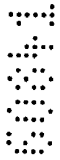

Invention Title:



Vortex flow meter detector and vortex flow meter



The following statement is a full description of this invention including the best method of performing it known to us:-

BACKGROUND OF THE INVENTION

5

The present invention relates to a vortex flowmeter detector and a vortex flowmeter, more particularly relates to a vortex flowmeter detector which is detachably cantilevered at one end in a vortex generation body, and outputs a vortex signal in response to an alternate pressure caused by Karman vortex and a vortex flowmeter provided with the vortex flowmeter detector.

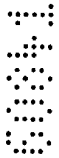

10

A vortex flowmeter is an inferential flowmeter which operates based on a principle that the number of Karman vortex generated per unit time by the vortex generation body supported in a flow tube is proportional to flow velocity in a given Reynolds number, wherein the inferential flowmeter has a vortex flowmeter detector for detecting the Karman vortex generated by the vortex generation body. There are two types of vortex flowmeter, one is an integration type having a vortex flowmeter detector integrally incorporated into the vortex generation body, and the other is a separate type having a vortex flowmeter detector disposed in a position where the vortex generation body is disposed. The integration type



15



20

flowmeter is advantageous in that it can be small sized.

5 In the prior art vortex flowmeter detector, both ends of the vortex generation body is engaged by means of heat shrinkage fit in a cylindrical flow tube through which fluid to be measured passes, wherein pressure introduction ports are bored at both sides of the vortex generation body. The pressure introduction ports communicate with a recessed measuring chamber 10 which is bored in the axial direction from one end of the vortex generation body together with the flow tube. There is formed a fixing surface at the outer wall of the flow tube, and the fixing surface has a surface which is perpendicular to an axis of the measuring chamber, wherein an oscillation tube having a fixing flange is cantilevered watertightly in the flow tube.

15 The oscillation tube comprises a cylindrical body having a bottom and a pressure receiving plate which extends coaxially outward from the bottom of the cylindrical body, wherein the pressure receiving plate faces the pressure introduction ports. An elastic plate-shaped base material which is flush with the pressure receiving plate is inserted into the cylindrical body in an axial direction, and 20 piezoelectric elements are stuck to both sides of the elastic base material, whereby the elastic base

material is integrally fixed to the cylindrical body with high insulating filler such as glass.

5 If the fluid to be measured flows in a direction perpendicular to a paper, a Karman vortex is generated downstream relative to the vortex generation body and an alternate pressure is generated at both sides of the vortex generation body. The alternate pressure is introduced into the measuring chamber through the pressure introduction ports provided in the vortex generation body at the upper and lower direction of the vortex generation body so as to displace the pressure receiving plate to the right and left. This alternate displacement is transmitted to the piezoelectric elements stuck to the cantilevered oscillation tube so that a vortex signal is outputted from terminals in response to the alternate pressure in proportion to the flow rate.

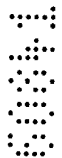

15



20



25

Although a vortex generation body, which is determined according to the bore diameter of the vortex flowmeter, is fixed to the vortex flowmeter, an oscillation tube having the common or same size is employed by the vortex flowmeter even if the sizes of the vortex generation bodies are differentiated. Further, since the vortex flowmeter detector having the same shaped oscillation tube which is cantilevered by and inserted into the measuring chamber of the vortex

generation body is employed, there is an advantage that the production is rationalized, thereby providing the vortex flowmeter with low cost.

5 As mentioned above, the vortex flowmeter has a simple structure comprising the cylindrical flow tube, the vortex generation body fixed inside the cylindrical flow tube and the vortex flowmeter detector mounted inside the vortex generation body, and it is an inferential flowmeter capable of measuring the flow rate to an extent predetermined by the Reynolds number irrespective of the kind of fluid, i.e., gas or liquid. 10 However, the shape of the vortex generation body and a relation between the vortex generation body and the inner diameter of the cylindrical flow tube are important in order to measure the flow rate with high accuracy within a wide range of the wide Reynolds number, and many proposals have been provided so far on this matter.

15 Among vortex flowmeters satisfying the above condition, there is one having the vortex generation body which is formed of an isosceles triangle in a cross section, wherein the upstream side thereof forms a base, and a ratio (d/D) of a width d of the vortex generation body facing the flow of fluid with respect to the inner diameter D of the cylindrical flow tube is 20 set to be a value close to 0.28, and the ratio of 25

inner diameter D with respect to the height of the isosceles triangle is set to be 1.5 to 3.5.

5 In the vortex flowmeter having such ratio (d/D) between the width d of the vortex generation body and the inner diameter D of the flow tube, is determined to be 0.28, the vortex generation body is fixed to the cylindrical flow tube while penetrating the flow tube in a direction of the diameter of the flow tube. Accordingly, the flow tube has holes defined in a direction of the diameter thereof, and the vortex generation body to be fitted into these holes has columnar portions, and they are sealed by the O rings engaged in the holes. The vortex generation body has a given isosceles triangle in its cross section in the passage wherein it has a base at an upstream side and is circular at the outer end surfaces, namely, it has different shapes in a cross section. The vortex generation body is retained by the flow tube with the bolt at a collar at one end and a presser ring at the other end. Accordingly, when the vortex generation body is viewed from the upstream side of the passage, the vortex generation body in the passage comprises a rectangular area portion formed by a base of a triangular prism, an arced area portion formed by a part of a wall surface of the passage and a short side of the rectangular portion.

10

15

20

25

Whereupon, although the vortex flowmeter is employed for measuring fluid having a wide range of temperature, ranging from a cryogenic LNG (liquefied natural gas) to a high temperature steam, etc., the first mentioned prior art vortex flowmeter detector uses glass as the filler, thereby generating the following problems.

5

(1) There occurs a problem of a corrosion resistance of the oscillation tube since glass is treated at high temperature and filled in the oscillation tube, thereby deteriorates strength of oscillation tube.

10

(2) It takes time for removing internal strain which is generated when glass is sealed, and to prevent air bubble from entering and mixing with glass, and hence the oscillation tube is difficult to be manufactured.

15

(3) There is a likelihood that a crack is generated in the oscillation tube or the oscillation tube is broken because of a fatigue caused by concentrated stress which occurs locally or thermal fatigue since a material of oscillation tube and coefficient of thermal expansion of glass before the internal strain of glass is removed is largely different from those after the internal strain of glass is removed.

20

25

(4) Since the flowmeter detector is directly exposed to fluid, especially when high temperature fluid, moisture enclosed in glass gradually reaches the piezoelectric elements so that insulating resistance is reduced and high temperature limit to be used is restricted.

5

(5) It takes time to dry vortex flowmeter detector, and also it is difficult to remove the moisture sufficiently even if the vortex flowmeter is dried.

10

(6) Although the parallel lead wires as lead wires which are covered with insulating material are employed, and they are inserted into a metallic pipe. However, when an output impedance of oscillation detection elements is high, a noise becomes large and a signal to noise ratio is deteriorated owing to the change of capacitance caused by oscillation.

15

The vortex generation body of the second prior art vortex flow meter is columnar at both ends and the part facing flow of fluid has a plurality stage of shapes comprising the isosceles triangle, and the flow tube must be bored so as to insert the vortex generation body therein depending on the shape of the vortex generation body, which involves high cost in manufacturing the vortex generation body. As a result, even if the vortex generation body is simple in a

20

25

structural sense, there is a disadvantage that it is expensive.

Summary of the invention

5 According to the present invention, there is provided a vortex
flowmeter detector for detecting an alternating pressure produced by a
Karman vortex in a vortex flow meter having a cylindrical flow tube through
which a fluid flows, the cylindrical flow tube having a vortex generation
body fixed within the cylindrical flow tube at right angles with respect to the
10 flow of the fluid, said vortex generation body having a measuring chamber
which is open at one end of the vortex generation body in an axial direction
thereof, said vortex flowmeter detector comprising:

an oscillation tube having a closed bottom, said oscillation tube being
inserted into said measuring chamber and supported watertightly at said
open one end of said measuring chamber;

15 an elastic base material member supported at least at two points inside
said oscillation tube in an axial direction thereof;

20 said elastic base material member having a spring plate fixed at one
end thereof and oriented perpendicular to said axial direction of said
oscillation tube, said spring plate having a radially extending notches defined
in its periphery, and said spring plate detachably engaging inside surfaces of
said oscillation tube, to provide one of said at least two points of support for
said elastic base material member; and

25 said elastic base material member having oscillation detector elements
fixed thereto at another one of said two points of support, wherein oscillation
caused by said alternating pressure acting upon said oscillation tube is
detected by said oscillation detection elements.

30 It is a preferred feature of the present invention to provide a vortex
flowmeter detector which can be commonly used in a vortex flowmeter
having various bores, and can measure flow rate of a wide range of fluid
under various temperature conditions with stability and high accuracy.

It is another preferred feature of the present invention to provide the
flowmeter which is integrally formed by a flow tube and a vortex generation
body with a precision casting, thereby reducing the cost of the flowmeter and
enhancing instrument error characteristics.

Brief Description of the Drawings

- 5 Fig. 1(A) and Fig. 1(B) are cross sectional views respectively explaining the first example of a prior art vortex flowmeter detector and vortex generation body;
- Fig. 2(A) and Fig. 2(B) are cross sectional views respectively explaining the second example of a prior art vortex flowmeter;
- Fig. 3(A) through Fig. 3(C) are cross sectional

5
6
7
8
9
10
11
12
13
14
15
16
17
18
19
20
21
22
23
24
25
26
27
28
29
30
31
32
33
34
35
36
37
38
39
40
41
42
43
44
45
46
47
48
49
50
51
52
53
54
55
56
57
58
59
60
61
62
63
64
65
66
67
68
69
70
71
72
73
74
75
76
77
78
79
80
81
82
83
84
85
86
87
88
89
90
91
92
93
94
95
96
97
98
99
100

views showing main parts of a vortex flowmeter detector according to the first embodiment of the present invention;

5 Fig. 4(A) through Fig. 4(C) are cross sectional views showing main parts of a vortex flowmeter detector according to the second embodiment of the present invention;

10 Fig. 5(A) through Fig. 5(C) are cross sectional views respectively explaining a vortex flowmeter provided with the vortex flowmeter detector according to the first embodiment of the present invention;



15 Fig. 6(A) and Fig. 6(B) are cross sectional views respectively explaining a vortex flowmeter provided with the vortex flowmeter detector according to the second embodiment of the present invention; and



Fig. 7(A) through Fig 7(C) are cross sectional views respectively explaining a vortex flowmeter provided with the vortex flowmeter detector according to the third embodiment of the present invention.



20

PREFERRED EMBODIMENT OF THE INVENTION

25

Fig. 1(A) is a cross sectional view for explaining a prior art vortex flowmeter detector, and Fig. 1(B) is a cross sectional view of a vortex generation body (taken along the arrows B-B in Fig. 1 (A)). In the

vortex flowmeter, both ends of a vortex generation body 12 are engaged by means of heat shrinkage fit in a cylindrical flow tube 11 so as to be fixed to the cylindrical flow tube 11, through which fluid to be measured flows. Pressure introduction ports 15 and 15 are bored in both sides of the vortex generation body 12. The pressure introduction ports 15 and 15 communicate with a recessed measuring chamber 14 which is bored from one end of the vortex generation body 12 together with the cylindrical flow tube 11 and extends axially in the vortex generation body 12. A fixed surface 13 is formed on the outer wall of the cylindrical flow tube 11 and is positioned perpendicularly to the axis of the measuring chamber 14. An oscillation tube 20 having a fixed flange 21 is cantilevered by the fixed surface 13 so as to be watertightly brought into contact with the cylindrical flow tube 11.

The oscillation tube 20 comprises a cylindrical body 16 having a bottom, and a pressure receiving plate 16a arranged coaxially with the cylindrical body 16 and extending outward from the bottom of the cylindrical body 16, wherein the pressure receiving plate 16a faces the pressure introduction ports 15 and 15.

A plate-shaped elastic base material 17 is inserted into the cylindrical body 16 in the axial direction of

the cylindrical body 16 and flush with the pressure receiving plate 16a. Piezoelectric elements 18 are stuck to both surfaces of the elastic base material 17 whereby the piezoelectric elements 18 are integrally fixed to the cylindrical body 16 by a filler or a sealing agent 19, which has high insulation property and is made of glass, etc.

5

10

When a fluid to be measured flows in a direction perpendicular to the paper surface in Fig. 1(A), Karman vortex is generated downstream relative to the vortex generation body 12 and an alternate pressure is generated at both sides of the vortex generation body 12. The alternate pressure is introduced into the measuring chamber 14 through the pressure introduction ports 15 and 15 which are provided at upper and lower portions of the vortex generation body 12 in Fig. 1(A) so as to displace the pressure receiving plate 16a alternately right and left. The alternate displacement is transmitted to the piezoelectric elements 18 which are stuck inside the cantilevered oscillation tube 20, so that a vortex signal, which is responsive to the alternate pressure caused by the Karman vortex and is proportional to the flow rate, is outputted from terminals 22.

15

20

25

Although a vortex generation body, a size of which is determined depending on a bore of a vortex

flowmeter, is fixed to the vortex flowmeter, the oscillation tube 20 having the same size is employed by the vortex generation bodies having various sizes. Further, since there is employed a vortex flowmeter
5 detector provided with an oscillation tube having the same shape which is cantilevered and inserted into the measuring chamber 14 of the vortex generation body 12, there is an effect that the production is rationalized, thereby providing the vortex flowmeter with low cost.

10 As mentioned above, the vortex flowmeter has a simple structure comprising the cylindrical flow tube 11, the vortex generation body 12 fixed inside the cylindrical flow tube 11 and the oscillation tube 20 mounted inside the vortex generation body 12, and it is
15 an inferential flowmeter capable of measuring the flow rate to an extent predetermined by the Reynolds number irrespective of the kind of fluid, i.e., gas or liquid. However, the shape of the vortex generation body 12 and a relation between the vortex generation body 12 and
20 the inner diameter of the cylindrical flow tube 11 are important in order to measure the flow rate with high accuracy within a wide range of the Reynolds number, and many proposals have been provided so far on this matter.

25 Among vortex flowmeters satisfying the above condition, there is one having the vortex generation

body 12 which is formed of an isosceles triangle in a cross section, wherein the upstream side thereof forms a base, and a ratio (d/D) between a width d of the vortex generation body 12 facing the flow of fluid and an inner diameter D of the cylindrical flow tube 11 is set to be about 0.28, and the ratio between the inner diameter D and a height of the isosceles is set to be 1.5 to 3.5.

A prior art vortex flowmeter body satisfying such condition is illustrated in Figs. 2(A) and 2(B). Fig. 2(A) and Fig. 2(B) are cross sectional views respectively explaining a second example of the prior art vortex flowmeter, wherein Fig. 2(A) is a cross sectional view taken along the arrows A-A in Fig. 2(B), and Fig. 2(B) is a cross sectional view taken along the arrows B-B in Fig. 2(A). Denoted by 31 is a flow tube, 32 is a passage, 33 is a vortex generation body, 34 are outer end surfaces, 35 and 36 are O-rings, 37 is a presser ring, 38 is a bolt, and an arrow F is a flowing direction of a fluid.

The ratio (d/D) between the width d of the vortex generation body 33 and the inner diameter D of the flow tube 31 is fixed to be 0.28 in the prior art vortex flowmeter shown in Fig. 2(A) and Fig. 2(B). The vortex generation body 33 is fixed to the cylindrical flow tube 31 while penetrating the flow tube 31 in a

direction of the diameter of the flow tube 31. Accordingly, the flow tube 31 has end surfaces 31a which are parallel with each other and the circular passage 32 has the diameter D. The flow tube 31
5 further has holes 31b, 31c and 31d which extend radially. The vortex generation body 33 to be fitted into these holes 31b, 31c and 31d at both ends has columnar portions 33b, 33c and 33d which are sealed by the O rings 35 and 36 engaged in the holes 31b, 31c and
10 31d. The vortex generation body 33 has a given isosceles triangle in its cross section in the passage 32 wherein it has a base at an upstream side and a plurality stage of shapes at the outer end surfaces 34 in a cross section, and it is retained by the flow tube
15 31 with a collar 33a at one end and a presser ring 37 at the other end by way of the bolt 38. Accordingly, in the case of Fig. 2(A) when the vortex generation body 33 is viewed from the upstream side of the passage 32, the vortex generation body 33 in the passage 32
20 comprises a rectangular area portion 33f formed by a base of a triangular prism, and an arced area portion 34a formed by an arc portion formed a part of a wall surface 32a of the passage 32 at both ends of the rectangular portion and a short side 33e of the
25 rectangular portion.

The vortex flowmeter is employed for measuring

fluid having a wide range of temperature, namely, fluid ranging from a cryogenic LNG (liquefied natural gas) to a high temperature steam, etc. However, the prior art vortex flowmeter detector shown in Fig. 1(A) uses glass as a filler or a sealing agent in the oscillation tube 20. As a result, there occurred the problems set forth in (1) through (6).

The vortex generation body 33 of the prior art vortex flowmeter as shown in Fig. 2(A) is columnar at both ends and has a plurality of stages of shapes comprising an isosceles triangle at a portion facing flow of fluid. The flow tube 31 must be bored for fitting the vortex generation body 33 corresponding to the shape of the vortex generation body 33, which costs high. As a result, there is a disadvantages that the prior art vortex flowmeter costs high even if it has a simple structure.

Fig. 3(A) through Fig. 3(C) are cross sectional views explaining the vortex flowmeter detector according to the first embodiment of the present invention, wherein Fig. 3(A) shows an entire structure, Fig. 3(B) is an enlarged cross sectional view taken along the arrows B-B in Fig. 3(A) and Fig. 3(C) is an enlarged cross sectional view taken along the arrows C-C in Fig. 3 (A). Denoted by 41 is an oscillation tube, 42 is an elastic base material, 43a and 43b are

respectively piezoelectric elements (oscillation
detection elements), 44a and 44b are respectively
electrode plates, 45 is a spring plate, 46 and 47 are
respectively output terminals, 48 is a cap, 49 is a
5 sheath pipe, 50 are lead wires respectively, 51 is a
terminal block, 52 is a hermetic terminal, 53 are
external lead wires, 54 are respectively terminals, 60
is a vortex flowmeter body (flow tube), 61 is a vortex
generation body, 62 is a passage, 63 is a measuring
10 chamber, 64a and 64b are respectively pressure
introduction ports .

The vortex flowmeter detector shown in Fig. 3(A) is
a vortex detector to be mounted on a vortex flowmeter
body comprising the cylindrical flow tube 60 and the
15 vortex generation body 61 which is supported in the
flow tube 60 at both ends thereof. A recessed
measuring chamber 63 is bored in the vortex generation
body 61 to extend axially from one end thereof, and the
pressure introduction ports 64a and 64b, which are
20 respectively open to both sides of the vortex
generation body 61, communicate with the measuring
chamber 63. A hole, which penetrates coaxially with
the measuring chamber 63, is bored in the flow tube 60,
and it has a detector fixing surface 60a which is
25 positioned perpendicular to the axis of the measuring
chamber 63.

The oscillation tube 41 is a cylindrical body having one end which is open and another end which has a bottom portion 41c, and further comprises a flange 41a at the outer periphery of the open one end thereof.

5 The oscillation tube 41 is inserted into the measuring chamber 63 and is cantilevered by and fixed to the detector fixing 60a by the flange 41a. A pressure receiving plate 41b is provided at the outside of the bottom portion 41c of the oscillation tube 41 which is
10 inserted into the measuring chamber 63, wherein the an alternate pressure caused by the vortex, which is introduced from the pressure introduction port 64a of the vortex generation body 61 to the measuring chamber 63, can be received by the pressure receiving plate 41b.

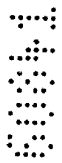

15



20

The elastic base material 42 has a metallic pillar-shaped body and is inserted into the oscillation tube 41, wherein one end of the elastic base material 42 is pressed into and fixed to the oscillation tube 41, and the other end thereof is supported by the plate 45, described later. As a result, the elastic base material 42 receives variable differential pressure caused by the Karman vortex acting upon the oscillation tube 41, and transmits the displacement of the
25 oscillation tube 41 which is alternately displaced to the oscillation detector elements with high fidelity.

5 The elastic base material 42 has an upper pressure fitted portion 42a at a part of the open upper end of the oscillation tube 41, an end portion 42c at the bottom portion 41c of the oscillation tube 41, wherein the end portion 42c has a flat surface with a small diameter, for example, it is cut in a tapered shape toward the lower end surface and is flat at the end surface. An outer diameter of the middle part of the elastic base material 42 is slightly smaller than the inner diameter of the oscillation tube 41 and does not contact the oscillation tube 41.

10 Two chamfers 42b are formed at the upper pressure fitted portion 42a, the oscillation detector elements, for example, the piezoelectric elements 43a and 43b are stuck to each surface of the upper pressure fitted portions 42a as shown in Fig. 3(B). The piezoelectric elements 43a and 43b have a piezoelectric constant d33 and are polarized in the direction of a thickness thereof. The electrode plates 44a and 44b which are respectively formed of a porous plate are stuck to the non-sticking surface of the piezoelectric elements 43a and 43b, thereby forming a parallel-typed bimorph. The piezoelectric elements 43a and 43b have one output terminal 47 formed of the elastic base material 42 and another output terminal 46 formed of the electrode plates 44a and 44b which are connected to each other.

Other strain detectors may be provided instead of the piezoelectric elements 43a and 43b.

5 The spring plate 45 having a perpendicular surface relative to the axis of the elastic base material 42 is fixed to the end portion 42c by a spot welding, etc. The plate 45 is discoidal and has an outer diameter which is slightly larger than the inner diameter of the oscillation tube 41 as shown in Fig. 3(C), and further includes a plurality of radially arranged notches 45a and a supporting piece 45b. The supporting piece 45b has a spring function in such a manner that the outer end portion thereof can be displaced relative to the end portion 42c in the axial direction of the elastic base material 42, wherein when the supporting piece 45b is pressed into the oscillation tube 41, it can be easily curved and inserted into the oscillation tube 41 in the inserting direction, thereby transmitting the oscillation displacement of the oscillation tube 41 to the elastic base material 42 with high fidelity.

10
15
20
25 The open upper end of the oscillation tube 41 is covered with the cap 48 which protects the oscillation detector elements and keeps insulation property. The sheath pipe 49 penetrates the center of the cap 48 and is fixed to the cap 48, and the other end of the sheath pipe 49 penetrates and is fixed to the terminal block 51 having the hermetic terminal 52. Two lead wires 50

are inserted into the sheath pipe 49, and are connected between the output terminals 46 and 47 and the hermetic terminal 52. The external lead wires 53 and 53 having the terminals 54 and 54 are connected to the hermetic terminal 52. When dry gas such as nitrogen gas is sealed into the terminal block 51 before the hermetic terminal 52 is fixed to the terminal block 51, the gas inside the cap 48 is replaced by such dry gas which passes through the sheath pipe 49, and hence the piezoelectric elements 43a and 43b remain insulated even if they are placed under a high or low temperature condition.

The vortex flowmeter detector having the arrangement shown in Fig. 3(A) can transmit the displacement of oscillation tube to the elastic base material by way of the sprig plate 45 having notches and fixed to the bottom end of the elastic base material 42 without using the filler or sealing agent such as glass whereas the elastic base material in the oscillation tube is sealed by glass so as to transmit the displacement of oscillation tube to the elastic base material onto which the oscillation detector elements are stuck in the prior art vortex flowmeter detector, so that the vortex flowmeter detector can be easily assembled and can reduce the time involved in manufacturing thereof. However, since the oscillation

tube 41 and the elastic base material 42 are fixed to each other and not separable from each other at the upper pressure portion 42a, there is a drawback that the operation of the vortex flowmeter must be stopped so as to prevent fluid from being spouted from the measuring chamber 63 of the vortex generation body 61 when the vortex flowmeter detector is inspected or replaced by another.

Fig. 4(A) through 4(C) are views for explaining a vortex flowmeter detector according to the second embodiment of the present invention, wherein Fig. 4(A) is a longitudinal cross sectional view of the vortex flowmeter detector, Fig. 4(B) is a cross sectional view of a vortex detection part, and Fig. 4(C) is a cross sectional view taken along the arrows C-C in Fig. 4(B). Denoted by 55 is a vortex detection part, 56 is an element cover, and 57 is a fixing flange to fix the element cover 56 to the oscillation tube 41. Elements which function same as those in Fig. 3(A) through Fig. 3(C) are denoted by the same reference numerals.

The vortex flowmeter detector as shown in Fig. 4(A) through 4(C) has such a structure that the oscillation tube 41 and vortex detection part 55 are detachably separated from each other so as to take out the vortex detection part 55 alone without stopping the flow of fluid. That is, the oscillation tube 41 is fixed

watertightly to the flow tube, and the vortex detection part 55 is detachable to the oscillation tube 41 by way of the element cover 56.

5 The vortex detection part 55 is sealed by the element cover 56 at areas P and Q where the piezoelectric elements 43a and 43b respectively stuck to the two chamfers 42b of the elastic base material 42 are put, and inactive gas is sealed into the vortex detection part 55. The fixing flange 57, which is
10 fixed to the open end of the oscillation tube 41, is provided at the outer periphery of the element cover 56. The oscillation tube 41 is supported by the spring plate 45, which has the radially recessed notches 45a and is fixed to a tip end 42d of the elastic base
15 material 42, and the fixing flange 57.

Since the element cover 56 and the elastic base material 42 are respectively supported by a circumferential part P of the two chamfers 42b and a
20 lower part Q of the two chamfers 42b as shown in Fig. 4(C), the alternate pressure acting upon the oscillation tube 41 is transmitted to the piezoelectric elements 43a and 43b which are respectively stuck to the elastic base material 42 by way of the spring plate
25 45 if a cylindrical part 55a at the lower portion of the element cover 56 is made thin and reduced in its rigidity.

Owing to the provision of the vortex detection part 55 having the element cover 56, the vortex detection part 55 is detachable without removing the oscillation tube 41 from the flow tube so that the vortex detection part 55 alone can be inspected without stopping the operation of a plant, and it can be removed and can be replaced by another.

5

Although the oscillation tube 41 and the elastic base material 42 are respectively made of metal, if they are different from each other in coefficient of thermal expansion, there is a possibility that heat indication is generated in the oscillation tube 41 and a crack is generated in the oscillation tube 41 owing to thermal fatigue so that the oscillation table is damaged when the oscillation tube 41 is used for a long time. When the coefficient of thermal expansion of the oscillation tube 41 is made the same as that of the elastic base material 42, the aforementioned possibility is prevented and the range of temperature is increased, thereby increasing the range of the use of the vortex flowmeter.

10

15

20

According to the vortex flowmeter detector of the second embodiment, since the oscillation tube 41 and the elastic base material 42 are formed separately and can be detached and attached without the filler or the sealing agent such as glass, and the elastic base

25

material 42 alone can be replaced by another, thereby providing the vortex flowmeter detector having high reliability with low cost. The flow tube comprising the oscillation tube 41 and the elastic base material
5 42 which are integrated with each other can be provided simply with low cost with respect to such vortex flow meter detector.

Fig. 5(A) through Fig. 5(C) are views for explaining a vortex flowmeter according to the first
10 embodiment of the present invention, wherein the vortex flowmeter is provided with the vortex flowmeter detector, Fig. 5(A) is a plan view, Fig. 5(B) is a front view as viewed from the downstream side in Fig. 5(B), and Fig. 5(C) is a cross sectional view taken
15 along the arrows C-C in Fig. 5(B). Denoted by 71 is a flow tube, 72 is a passage, 73 is a vortex generation body, and 74 is an arc protrusion.

In Fig. 5(A), the flow tube 71 is an example of a so-called flangeless flow tube comprising a cylindrical
20 body having the passage 72 an inner diameter of which is D and is extended coaxially with the axis O-O' thereof, and it is coaxially held on a flow tube (not shown) through which fluid to be measured passes between flanges of such flow tube and is pressed by
25 bolts, etc. The flow tube 71 includes end surfaces 71a and 71a which are parallel with the flange surface

of the flow tube, and a vortex generation body 73 having a shape of a triangular prism for dividing the passage 72 at right angles with the axis O-O'. The vortex generation body 73 has a given pillar-shaped body in its cross section, and is formed of an isosceles triangle in a cross section comprising a base 73a, which faces flow of fluid in the direction of F, and inclined sides 73b and 73c. The both ends of the vortex generation body 73 to be connected to a wall surface 72a of the passage 72 form the arc protrusion 74 which is surrounded by circular outer end surfaces 74a circumscribing the isosceles triangle in the direction at right angles with the axis of the vortex generation body 73 and arcs 74b of the passage 72. Further, there are provided in the vortex generation body a plurality pairs of pressure introduction ports 73d and 73e which respectively communicate with a measuring chamber wherein the measuring chamber is open at one end in the axial direction.

The dimensional ratio between the width d of the vortex generation body 73 of the vortex flowmeter in the direction of the flow of fluid and the diameter D of the cylindrical passage 72 and a preferable value of the vortex generation body 73 are set in such a manner that the dimensional ratio (d/D) is set to be 0.2 - 0.4 and the inclination angle with respect to the axis O-O'

of the inclined sides 73b and 73c of the isosceles triangle is in a given angle range, and the arc protrusion 74 is provided so that the vortex column caused by the Karman vortex flowing out from the vortex generation body 73 is peeled off substantially in parallel with the vortex generation body 73, thereby forming substantially a two dimensional Karman vortex, whereby the Re characteristics relative to the instrument error is remarkably improved.

5
10
15
20
25
The flow tube 71, the vortex generation body 73, and the arc protrusions 74 shown in Fig. 5(A) are integrally formed by precision casting, for example, by a lost-wax process (investment casting method). The lost-wax method comprises preparing a mold of the vortex flowmeter detector made of heat soluble material such as bees wax, covering the mold with refractory material such as silica sand, powdered lime, heating the heat soluble mold to thereby melt the mold, introducing casting metal such as a stainless steel into a hollow mold and solidifying the casting metal, and removing the refractory material. The surface of the vortex flowmeter is subject to a surface treatment by a sand blast, etc. so as to be become a smooth surface.

The vortex flowmeter which was thus subject to the surface treatment has a detector fixing surface 71b for

fixing the vortex flowmeter detector to the outer wall thereof, and bores are defined in the measuring chamber which is provided in the vortex generation body 73 to extends from the detector fixing surface 71b in the axial direction of the vortex generation body 73, wherein the bores of the measuring chamber communicate with the pressure introduction ports 73d, 73d, 73e and 73e, thereby forming the vortex flowmeter having a given characteristic of instrument error.

Fig. 6(A) and Fig. 6(B) are views for explaining a vortex flowmeter according to the second embodiment of the present invention, wherein the vortex flowmeter is provided with the vortex flowmeter detector. Fig. 6(A) is a plan view, and Fig. 6(B) is a cross sectional view taken along the arrows B-B in Fig. 6(A). Denoted by 75 is a vortex generation body and 76 are arc flat plate portions. Elements which function same as those in Fig. 5(A) through Fig. 5(C) are denoted by the same reference numerals in Fig. 5(A) to Fig. 5(C).

The vortex generation body 75 of the vortex flowmeter as shown in Fig. 6(A) and Fig. 6(B) has an isosceles triangle having a base 75a at an upstream side and both sides 75b and 75c in the same manner as the vortex generation body 73 in a cross section in Fig. 5(C), wherein the connecting portion between the vortex generation body 75 and the flow tube 71 is

provided with the arc flat plate portions 76 instead of the arc protrusions 74. The arc flat plate portions 76 are flat plate portions which from the base 75a at a portion adjacent to the connecting portion of the vortex generation body 75 to the wall surface 72a at the upstream side of the passage 72 so as to protrude in an arc shape.

In the prior art vortex flowmeter, for example, the vortex flowmeter as shown in Fig. 2(A) and Fig. 2(B), a horseshoe vortex comprising vortex threads is generated from the upstream side of the portion adjacent to the wall surface of the passage and the vortex generation body 33 to the downstream side thereof and it is flown out. The horseshoe vortex is a vortex which is generated when dynamic pressure caused by the flow of fluid is high at the center of a surface 33f at the upstream side of the vortex generation body 33 at the upstream side of the vortex generation body 33, and is low at both sides of the vortex generation body 33, and also small at a passage wall surface 32a, and this horseshoe vortex is generated at the boundary layer of the passage wall surface 32a at the portion adjacent to the vortex generation body 33. The horseshoe vortex generated at the boundary layer of the passage wall 32a is peeled off in parallel with the vortex threads extending from the sides of the vortex generation body

33, and is flown out. As a result, it disturbs the Karman vortex which is flown out from the vortex generation body 33, thereby deteriorating the instrument error/Reynolds number characteristics, so that it is easily influenced by the piping system. The arc flat plate portions 76 are provided for removing the horseshoe vortex.

Fig. 7(A) through Fig. 7(C) are views for explaining a vortex flowmeter according to the third embodiment of the present invention, wherein the vortex flowmeter is provided with the vortex flowmeter detector. Fig. 7(A) is a plan view as viewed from the flowing direction, Fig. 7(B) is a side view, and Fig. 7(C) is a cross sectional view taken along the arrows C-C in Fig. 7(B). Elements which function same as those in Fig. 6(A) and Fig. 6(B) are denoted by the same reference numerals.

A vortex generation body 75 shown in Fig. 7(A) through Fig. 7(C) has an isosceles triangular prism having a length which is the same as the inner diameter D (passage) of the flow tube 71, and the width d facing the flow of fluid, and a length L in the flowing direction, wherein these dimensions range as follows.

$$0.2 < d / D < 0.4 \quad (1)$$

$$1.5 < D / L < 3.5 \quad (2)$$

If the arc flat plate portions 76 are provided in

the vortex flowmeter having the vortex generation body 75 having such dimensions, the instrument error/Reynolds number characteristics are improved, as mentioned above. In addition to that, an experiment carried out by the applicant of this invention revealed that the flow rate instrument error characteristics were improved if the dimension of the arc flat plate portions 76 set as follows.

$$0.03 D < m < 0.07 D \quad (3)$$

$$0.04 D < h < 0.07 D \quad (4)$$

That is, the instrument error is $\pm 0.5\%$ if Reynolds number (Re number) is in the range of $2 \times 10^4 - 10^7$, and a relative instrument error with respect to a meter constant reveals that it exceeds -1% if the length of straight tube is $5D$ but it is $\pm 0.5\%$ or less if the length of the straight tube is $10D$ or more in case that the test performed under the condition that the length of the straight tube at the upstream side is $40 D$ when one 90° elbow and a double elbow are provided at the upstream side.

The present invention has the effect that the arc flat plate portions 76 remove the horseshoe vortex which is flown out from the vortex generation body 75, and generates the two dimensional Karman vortex, thereby reducing the influence by the piping system. The vortex flowmeter according to the third embodiment

can be integrally formed by precision casting like the first embodiment, thereby providing the vortex flowmeter with high precision and low cost.

7
8
9
0
1
2
3
4

THE CLAIMS DEFINING THE INVENTION ARE AS FOLLOWS:-

1. A vortex flowmeter detector for detecting an alternating pressure produced by a Karman vortex in a vortex flow meter having a cylindrical flow tube through which a fluid flows, the cylindrical flow tube having a vortex generation body fixed within the cylindrical flow tube at right angles with respect to the flow of the fluid, said vortex generation body having a measuring chamber which is open at one end of the vortex generation body in an axial direction thereof, said vortex flowmeter detector comprising:
- 5 an oscillation tube having a closed bottom, said oscillation tube being inserted into said measuring chamber and supported watertightly at said open one end of said measuring chamber;
- 10 an elastic base material member supported at least at two points inside said oscillation tube in an axial direction thereof;
- 15 said elastic base material member having a spring plate fixed at one end thereof and oriented perpendicular to said axial direction of said oscillation tube, said spring plate having a radially extending notches defined in its periphery, and said spring plate detachably engaging inside surfaces of said oscillation tube, to provide one of said at least two points of support for said elastic base material member; and
- 20 said elastic base material member having oscillation detector elements fixed thereto at another one of said two points of support, wherein oscillation caused by said alternating pressure acting upon said oscillation tube is detected by said oscillation detection elements.
2. A vortex flowmeter detector according to claim 1, further comprising a cylindrical element cover for sealing lead wires extending from said oscillation detector elements, said cylindrical cover detachably interconnecting said elastic base material member and said oscillation tube to provide said another one of said two points of support whereby said elastic base material member is detachably supported in said oscillation tube by way of said element cover.
- 25 of said element cover.
- 30 3. A vortex flowmeter detector according to claim 1 or 2, wherein the coefficient of thermal expansion of the material forming the oscillation tube is substantially the same as that of the material forming the said elastic base material member.

4. A vortex flowmeter comprising said vortex flowmeter detector including said cylindrical flow tube and said vortex generation body according to any one of claims 1 to 3, wherein:

said cylindrical flow tube has a cylindrical body, said vortex generation body has a center portion in the form of an isosceles triangular prism having a cross-section in the form of an isosceles triangle with a base at an upstream side of said vortex generation body, and end portions on opposing ends of said center portion attached to inner walls of said flow tube;

said end portions being circular and circumscribing ends of said isosceles triangular prism; and

wherein said cylindrical flow tube and said vortex generation body are integrally formed with each other.

5. A vortex flowmeter comprising said vortex flowmeter detector including said cylindrical flow tube and said vortex generation body according to any one of claims 1 to 3 wherein:

said cylindrical flow tube has a cylindrical body, said vortex generation body is in the form of an isosceles triangular prism having a cross-section in the form of an isosceles triangle with a base at an upstream side of said vortex generation body, and opposing ends of isosceles triangular prism attached to inner walls of said flow tube;

said vortex generation body further comprising arc shaped flat plate portions provided at said opposing ends of said vortex generation body and fixed to said flow tube, said arc shaped flat plate portions each protruding from a base surface of said isosceles triangular prism in an upstream direction along said inner walls of said flow tube; and

wherein said flow tube and said vortex generation body are integrally formed with each other.

6. A vortex flowmeter according to claim 5, wherein ranges of dimensions are as follows:

$$0.2 < d/D < 0.4$$

$$1.5 < D/L < 3.5$$

$$0.03D < m < 0.07D$$

$$0.04D < h < 0.07D$$

where D is an inner diameter of said flow tube, d is a width of said base of said isosceles triangular prism facing upstream, L is a length of said

vortex generation body in a direction of said flow of fluid, and m is the maximum length of said arc shaped flat portions protruding perpendicularly from said base of isosceles triangular prism, and h is a height of said arc shaped flat portions in an axial direction of said isosceles triangular prism.

- 5 7. A vortex flowmeter detector substantially as hereinbefore described with reference to and as shown in Figures 3(A) to 3(C), or Figures 4(A) to 4(C) of the drawings and optionally in conjunction with any of Figures 5 to 7 of the drawings.

Dated this thirtieth day of October 1998

OVAL CORPORATION
Patent Attorneys for the Applicant:

F B RICE & CO

5
7
3
4
5
6
7

FIG.1A
(PRIOR ART)

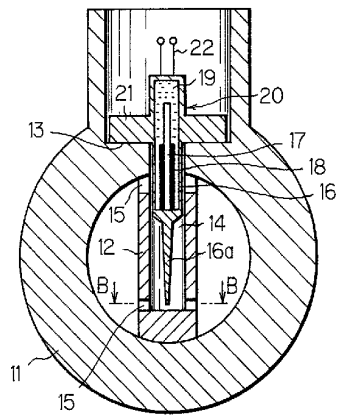

FIG.1B
(PRIOR ART)

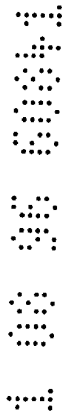
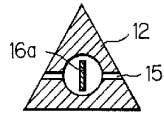

FIG.2A
(PRIOR ART)

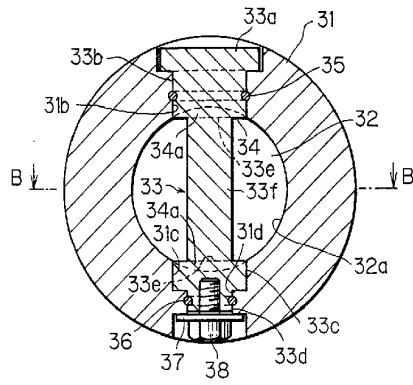
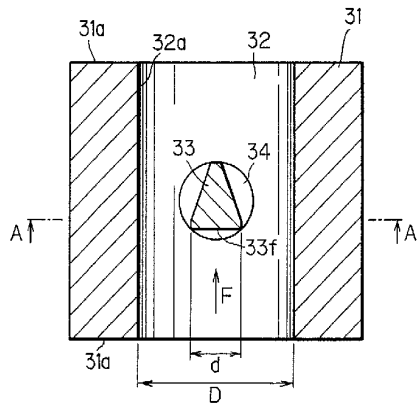

FIG.2B
(PRIOR ART)



60871/96

FIG.3A

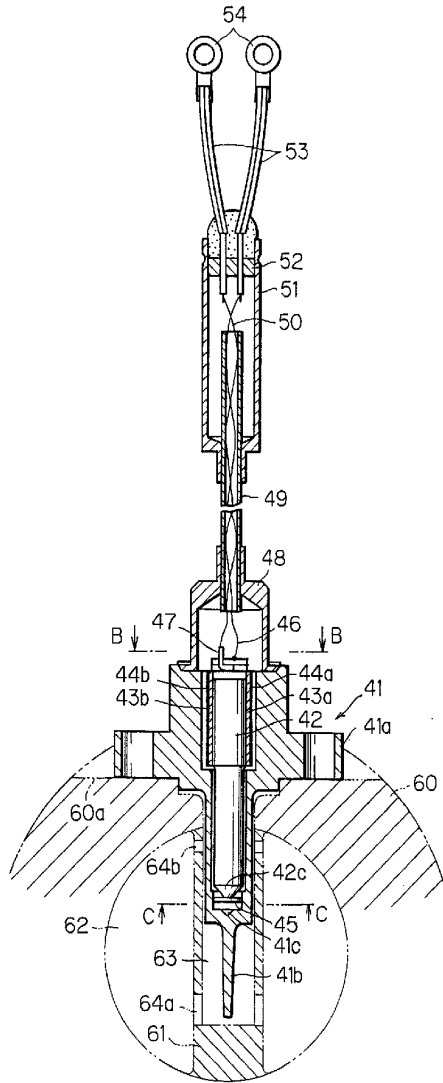

FIG.3B

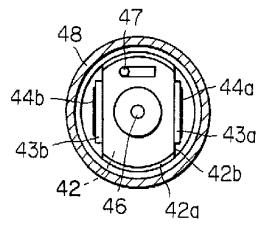

FIG.3C

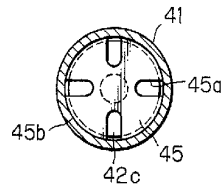

FIG.4A

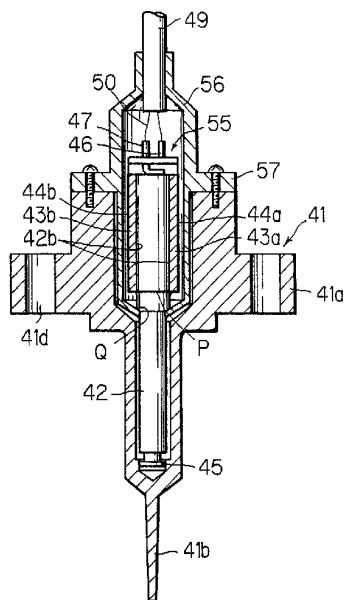

FIG.4B

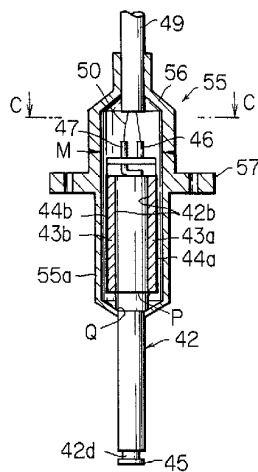
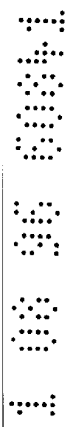
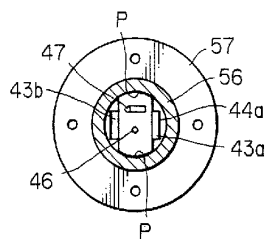

FIG.4C



60841/96

FIG.5A

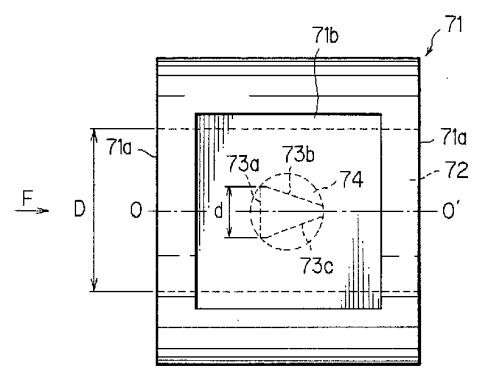

FIG.5B

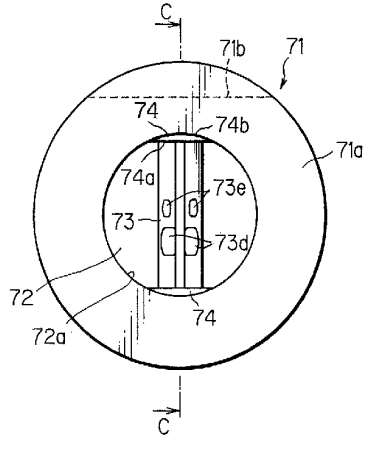

FIG.5C

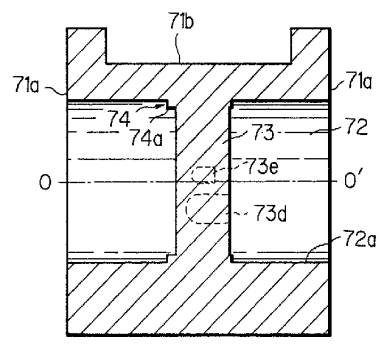

FIG.6A

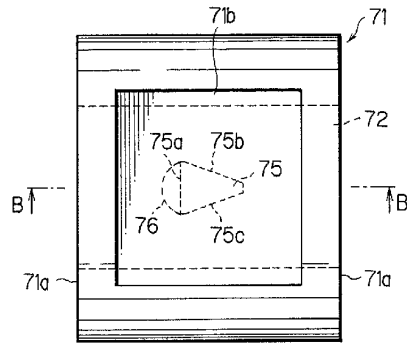

FIG.6B

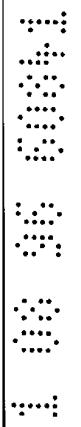
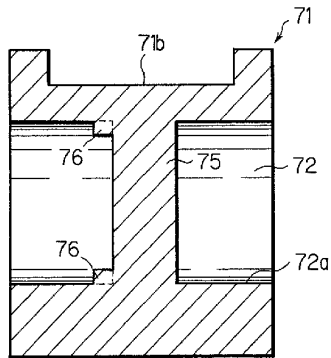

FIG.7A

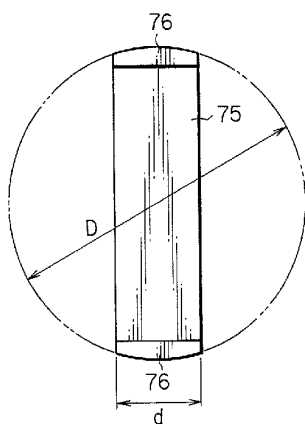

FIG.7B

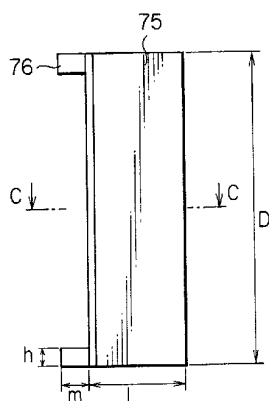

FIG.7C

