



(72) ROUSE, GEOFFREY OWEN, GB
(72) BROUSSARD, ANDRE NOLE, US
(72) SEGURA, RICHARD JAMES SR., US
(72) SCHNITKER, MARK WILLIAM, US
(72) HART, SHANE PAUL, US
(71) WEATHERFORD/LAMB, INC., US

(51) Int.Cl.⁶ E21B 31/16, E21B 31/18

(30) 1998/01/22 (09/010,782) US

(54) **SYSTEME, APPAREIL ET PROCEDE FACILITANT LA
RECUPERATION D'UN OBJET DANS UN Puits**

(54) **SYSTEM, APPARATUS AND METHOD FOR FACILITATING
RETRIEVAL OF AN ITEM FROM A WELL**

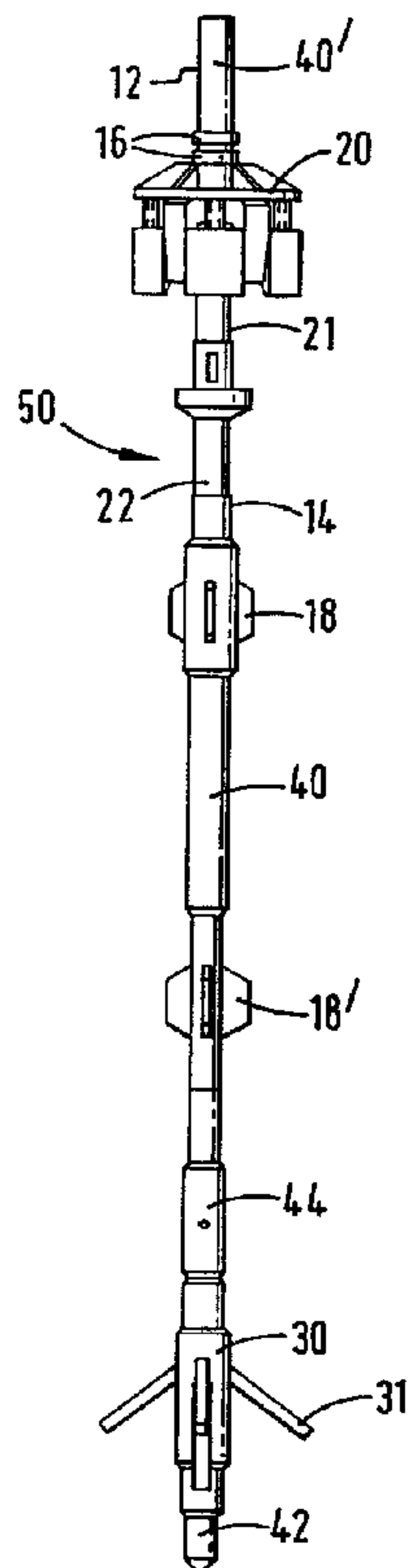

(57) L'invention porte sur un appareil de récupération d'un objet, par exemple une tête de forage, dans un puits, comportant des moyens (28) saisissant ledit objet et des moyens de verrouillage (66, 68) empêchant l'objet de se détacher inopinément. L'invention porte également sur un système de récupération d'un objet dans un puits

(57) An apparatus for facilitating retrieval of an item, for example a well head, from a well, said apparatus comprising means (28) for engaging said item characterised in that said apparatus further comprises locking means (66, 68) for inhibiting said means (20) from inadvertently releasing said item. A system for



comportant un grappin (20) et un outil de coupe (30) placé dessous et comportant des moyens (122, 154) d'expulsion d'un fluide sous pression situés au-dessus dudit outil de coupe. L'invention porte de plus sur une méthode de récupération d'un objet dans un puits recourant au système de l'invention et consistant à introduire au moins une partie du susdit outil de coupe dans un élément tubulaire, à l'y faire tourner alors qu'une de ses parties au moins, en contact avec l'élément tubulaire, le découpe en produisant des copeaux alors qu'on expulse le liquide au-dessus dudit outil de coupe pour empêcher que lesdits copeaux n'atteignent le grappin. L'invention porte en outre sur un appareil de récupération d'un objet dans un puits comportant au moins un bras (28) muni d'au moins une rainure (59, 59a) recevant les débris qui sans cela pourraient empêcher le fonctionnement dudit appareil.

facilitating retrieval of an item from a well, the system comprising a grapple (20), and a cutting tool (30) arranged therebelow characterised in that said system further comprises means (122, 154) for expelling fluid under pressure disposed above said cutting tool (30). A method for facilitating retrieval of an item from a well using the system of the invention, the method comprising the steps of inserting at least part of said system into a tubular, rotating said cutting tool, at least part of said cutting tool engaging said tubular to cut said tubular, which cutting action generates swarf characterised in that said method comprises the step of expelling fluid above said cutting tool for inhibiting said swarf reaching said grapple. An apparatus for facilitating retrieval of an item from a well, said apparatus comprising at least one arm (28), characterised in that said at least one arm (28) comprises at least one groove (59, 59a) for receiving debris that might otherwise inhibit the operation of said apparatus.

Abstract

An apparatus for facilitating retrieval of an item, for example a well head, from a well, said apparatus comprising means for engaging said item characterised in that said apparatus further comprises locking means for inhibiting said means from inadvertently releasing said item. A system for facilitating retrieval of an item from a well, the system comprising a grapple, and a cutting tool arranged therebelow characterised in that said system further comprises means for expelling fluid under pressure disposed above said cutting tool. A method for facilitating retrieval of an item from a well using the system of the invention, the method comprising the steps of inserting at least part of said system into a tubular, rotating said cutting tool, at least part of said cutting tool engaging said tubular to cut said tubular, which cutting action generates swarf characterised in that said method comprises the step of expelling fluid above said cutting tool for inhibiting said swarf reaching said grapple. An apparatus for facilitating retrieval of an item from a well, said apparatus comprising at least one arm, characterised in that said at least one arm comprises at least one groove for receiving debris that might otherwise inhibit the operation of said apparatus.

- 1 -

System, Apparatus and Method for facilitating retrieval
of an Item from a Well

This invention relates to a system, an apparatus and a method for facilitating retrieval of an item from a well and more particularly, but not exclusively, for
5 retrieving a well head from a sub-sea well.

A well head is used to control the flow of well fluids in a well bore. The well head is usually located at the top of the well bore. In marine environments the
10 well head is usually located on the seabed. The well head is generally mounted on a base plate and attached to a casing string which forms part of the well bore.

When the well runs dry, or it becomes uneconomic to obtain oil or gas therefrom, the well is closed down.
15 Well heads are expensive, therefore it is desirable to retrieve well heads. It is also mandatory to remove well heads in certain areas.

Prior to the present invention, well heads were retrieved using apparatus similar to that disclosed in
20 GB-A-2 259 930. GB-A-2 259 930 discloses a tool suspended on a drill string, which tool comprises a grapple for engaging the top of a string of casing to which a well head is attached and which is to be retrieved. The tool further comprises a mud motor and a rotary cutter
25 depending from a rotor of the mud motor for cutting the casing at a location below the grapple. The well head can be cut and lifted to the surface in one operation.

There have been problems with prior art apparatus for facilitating retrieval of a well head from a subsea
30 well. In particular, during retrieval of the well head, the arms of the grapple underlie a flange on the casing. The apparatus relies on the weight of the wellhead acting on the arms of the grapple preventing inadvertent release of the wellhead. After the casing is cut the wellhead is
35 lifted through the sea to the surface. In certain sea

- 2 -

states, particularly sea states with large swells, an upward force can be applied to the well head which is sufficient to disengage the well head from the grapple. This unfortunate event has occurred at least once.

5 The first aspect of the present invention attempts to reduce this problem.

 According to a first aspect of the invention there is provided an apparatus for facilitating retrieval of an item from a well, said apparatus comprising means for
10 engaging an item, for example a grapple characterised in that said apparatus further comprises locking means for inhibiting said means from inadvertently releasing said item.

 Preferably, said apparatus further comprises a
15 mandrel, said means for engaging an item, for example a well head, mounted thereon.

 Preferably, said locking means is actuatable by movement of said mandrel.

 Advantageously, one of said mandrel and said means
20 comprises at least one lug moveably arranged in a channel in the other of said mandrel and said means, such that, in use, one of said lug and said channel can move from a first position in which said means is able to release said item to a second position in which said means is
25 inhibited from releasing said item. Preferably, one of lug and said channel, in use, moves from said first position to said second position on rotation of said mandrel with respect to said means. Alternatively, one of said lug and said channel, in use, moves from said first
30 position to said second position by longitudinal movement of said mandrel with respect to said means. Preferably, one of said lug and said channel, in use, moves from said first position to said second position by a combination of rotating said mandrel and longitudinal movement of
35 said mandrel with respect to said means.

- 3 -

Preferably, said means comprises a housing and at least one arm moveable thereon.

Advantageously, said at least one arm is moveable about a pivot on said housing.

5 Preferably, said mandrel comprises a shoulder, which in use, moves said arm into engagement with said item to be retrieved upon movement of said mandrel.

10 There is also provided a system incorporating a cutting tool, for example a casing cutter and an apparatus in accordance with the first aspect of the invention.

Preferably, said system further comprises a mud motor.

* * *

15 Another problem with prior art apparatus for facilitating retrieval of a well head from a submerged well is that swarf generated by the cutting tool can impede the operation of the grapple.

20 A second aspect of the present invention attempts to reduce this problem.

According to a second aspect of the invention there is provided a system for facilitating retrieval of a item from a well, the system comprising a grapple, and a cutting tool arranged therebelow, characterised in that 25 said system further comprises means for expelling fluid under pressure, disposed above said cutting tool.

In use, the fluid tends to inhibit the swarf travelling upwardly and interrupting with the operation of the grapple.

30 Advantageously, said means is located above said cutting tool and below said grapple.

Preferably, said system comprises a downhole motor driven by a fluid, wherein at least part of the exhausted fluid is expelled through said means.

35 Advantageously, said means comprises at least one

- 4 -

hole. Preferably, said at least one hole is located in a rotating part of said mud motor. Alternatively, said hole may be located in the housing of the grapple.

Advantageously, said means is located in a sub.

5 There is also provided a method for facilitating retrieval of an item from a subsea well using the apparatus of the invention, the method comprising the steps of inserting at least part of said apparatus into a tubular, rotating said cutting tool, at least part of
10 said cutting tool engaging said tubular to cut said tubular, which cutting action generates swarf characterised in that said method comprises the step of expelling fluid above said cutting tool for inhibiting said swarf reaching said grapple.

15

* * *

An apparatus for facilitating retrieval of an item from a well bore, said apparatus comprising at least one arm, characterised in that said at least one arm comprises at least one groove for receiving debris that
20 might otherwise inhibit the operation of said apparatus.

- 5 -

For a better understanding of the present invention, reference will now be made, by way of example, to the accompanying drawings, in which:

5 Figure 1 is a side view of one embodiment of a system for retrieving a well head, the system incorporating an apparatus in accordance with a first aspect of the invention;

Figure 2 is a side view of a modified system for retrieving well head;

10 Figure 3A is a side cross-sectional view of part of the apparatus of Figures 1 and 2;

Figure 3B is a cross-sectional view taken along line 3B-3B of Figure 3A at a first stage of operation;

15 Figure 3C is a cross-sectional view taken along line 3C-3C of Figure 3A at a first stage of operation;

Figure 3D is a cross-sectional view taken along line 3B-3B of Figure 3A at a second stage of operation;

Figure 3E is a cross-sectional view taken along line 3C-3C of Figure 3A at a second stage of operation;

20 Figure 3F is an end view of a first embodiment of an arm of the apparatus of Figure 3A;

Figure 3G is an end view of a second embodiment of an arm of the apparatus of Figure 3A;

25 Figure 4A is a bottom view of part of the apparatus of Figure 3A;

Figures 4B - 4C are cross-sectional views of the parts of the apparatus shown in Figure 4A;

Figure 4D is a top view of part of the apparatus of Figure 3A;

30 Figures 4E - 4G are cross-sectional views of parts of the apparatus of Figure 3A;

Figure 5A is a top view, partly in cross-section, of a part of the apparatus of Figure 3A;

35 Figure 5B is a cross-sectional view taken along line 5B-5B of Figure 5A;

- 6 -

Figure 6 is a side cross-sectional view of a part of the apparatus of Figure 2;

Figure 7A is a side cross-sectional view of a part of the apparatus of Figure 3A;

5 Figure 7B is a cross-sectional view taken along line 7B-7B of Figure 7A;

Figure 7C is a cross-sectional view taken along line 7C-7C of Figure 7A;

10 Figure 8A is a top view of a part of the apparatus of Figure 3A;

Figure 8B is a cross-sectional view taken along line 8B-8B of Figure 8A; and

Figure 8C is a side cross-sectional view of the part of the apparatus of Figure 8A.

15 Figure 1 shows a system for retrieving a well head. The system is generally identified by reference numeral 10.

The system 10 comprises an apparatus 20 and a casing cutter 30 arranged therebelow. An upper part 40' of a mud motor 12 is positioned in a drill string 14. Two safety clamps 16 are secured around the upper part of the mud motor 12. A lower part 22 of a central mandrel 21 of the apparatus 20 is threadedly connected to a stabilizer 18. A lower part 40 of mud motor 12 (e.g. as is typical with a bearing assembly and into which the power shaft extends) is connected in the string 14 below the stabilizer 18 and a lower stabilizer 18' is connected below the lower part 40 of the mud motor 12. The casing cutter 30 is threadedly connected below the lower stabilizer 18'. A bull sub 42, made of rubber-coated steel is connected below the casing cutter 30 and inhibits damage to the wellhead as the apparatus is moved through it prior to cutting of the casing.

25 The safety clamps 16 are used on the upper part 40' of the mud motor 12 above the gripping apparatus to limit

- 7 -

the downward movement of the upper part 40' of the mud motor 12 thereby limiting the length of casing that is cut (and to be retrieved) and to ensure that cutting ceases at a desired point. In another aspect in which a
5 drill string is used that is rotatable (e.g. in a common rotary rig) without a mud motor, no safety clamps are used; and, in one aspect of such a system, a marine swivel is used on top of the system 10 to facilitate rotation.

10 Figure 2 shows a system generally identified by reference numeral 50.

The system 50 is similar to the system 10 shown in Figure 1, with the addition of a drain sub 44 located between the lower stabilizer 18' and the casing cutter
15 30. The drain sub 44 exhausts into a wellbore annulus outside the drain sub 44 above the cutting blades 31. This reduces the pressure drop across the casing cutter 30 or increases the pressure above the casing cutter 30 to that below the cutting blades 31. The reduction in
20 fluid pressure across the cutting tool 30 results in a reduced tendency for swarf including cuttings and debris to be pumped up the wellbore annulus. A portion of the fluid under pressure flowing from the lower part 40 of the mud motor flows through the cutting tool 30 and is
25 applied thereto in order to maintain activation of the cutting blades 31.

Figure 6 shows the drain sub 44 which has a flow bore 121 therethrough from top to bottom and an exhaust port 122 in the wall 44 thereof. There may be several
30 exhaust ports arranged about the drain sub 44. The system 50 may include any known drain sub or dump sub or a sub with orifices or ports originally blocked by ruptureable discs or shear members. An orifice 123 is held in place in the exhaust port 122 by a snap ring 124. Use of such
35 an orifice 123, or one of a series of orifices with

- 8 -

different inner diameters, permits precise control of the fluid flowing from the drain sub 44. The exhaust port 122 is angled downwards towards the blades of the casing cutter 30, when the cutting blades 31 are in an extended position.

In one particular embodiment the total flow to the mud motor 12 is about 3300 litres per minute (875 gallons per minute), the flow out the exhaust port 122 is about 1800 litres per minute (475 gallons per minute), and the flow to the cutting tool 30 is about 1500 litres per minute (400 gallons per minute). In this aspect the orifice 123 has a diameter of about 1.75cm (0.689 inches) and the exhaust port 122 has a diameter of about 1.9cm (0.75 inches). The drain sub 44 can be positioned anywhere below the lower part 40 of the mud motor 12 and above the casing cutter 30.

Figure 3A shows a part of the apparatus 20. The central mandrel 21 has a flow bore 67 therethrough and extends movably longitudinally and rotatably through a bonnet 23 and through a housing 24. The housing 24 has a three arm supports 25, each provided with a pin 26 about which each arm 28 is moveable. Each pin 26 is made from hardened steel or a similar material, and secured in a slot 27 in each arm support 25. Each pin 26 may be circular or, in one aspect they may be elongated (as viewed from above) and shaped to correspond to the shape of each slot 27. Each arm 28 is pivotably and latchably mounted on each pin 26 so that upon upward movement of the central mandrel 21 an upper shoulder 29 thereof contacts a lower surface 61 of the arms 28 causing them to pivot downwardly in arm slots 161 of the housing to a position as shown in Figure 3A with a lip latch portion 62 engaging an item to be held, for example, a wellhead (not shown).

A spline spacer 46 (Figure 5B) is secured on the

- 9 -

central mandrel 21, by bolts and/or welding. The top 48
of the spline spacer 46 serves to assure correct
positioning of the central mandrel 21 with respect to the
housing 24 both for correct activation of each arm 28 and
5 to correctly position co-operative locking apparatus to
be described below. A spring (not shown) may be disposed
between each arm 28 and the bonnet 23 to urge each arm 28
to an unlatched position.

The bonnet 23 is secured to the housing 24 with a
10 series of bolts 52 extending through a series of support
pillars 54 placed between the bonnet 23 and the housing
24. The bonnet 23 also sits on pillars 152 extending
upwardly from the housing 24. Holes 154 permit fluid
under pressure to flow to a top surface 56 of the arms 28
15 to flush debris and cuttings away so that proper movement
of the arms 28 is not impeded when the central mandrel 21
moves up to activate the arms.

Figures 3F and 3G show an end view of an end 58 of
one of the arms 28, illustrating a series of notches or
20 valleys 59 (Figure 3F) or one notch 59a (Figure 3G) made
or formed integrally in the arm. These notches or
valleys may collect debris in such a way that it does not
impede proper arm movement. They also facilitate
flushing of debris from the top of the arm by providing a
25 channel for movement therefrom.

The system and apparatus according to the present
invention can be used, among other things, to retrieve a
wellhead and the parts that engage and/or accommodate the
wellhead can be customized, configured, and positioned
30 for any particular wellhead. This includes a space 64
between the arms 28 and the central mandrel 21.

Referring to Figures 3B to 3E there is shown the
central mandrel 21 with a plurality of projecting lugs 66
which are positioned for movement into and out of a
35 groove 68 which extends around an interior of the housing

- 10 -

24 and into which, through slots 72 in the housing 24, the lugs 66 are movable to achieve co-operative releasable locking of the mandrel 21 in place. The slots 72 permit the lugs 66 to move into alignment with the groove 68 as the central mandrel 21 is raised (and the latching arms 28 grip a wellhead) so the lugs 66 can then be rotated into the groove 68.

Initially as the central mandrel 21 is moved upwardly, the lugs 66 move up within the housing 24 in slots 72 until they are at the level of the groove 68. Then the central mandrel 21 is rotated (to the left about 60 degrees - counter-clockwise viewed from above) to move the lugs 66 into the groove 68, thus releasably locking the central mandrel 21 in place so that the arms 28, now engaging an item, such as a wellhead, and inhibiting inadvertent release. Upon further subsequent right-hand rotation of the central mandrel 21, the lugs 66 again align with the slots 72 at which point the lugs 66 can move out of the grooves 68, downwardly in the slots 72, and away from the housing 24, permitting release of the arms 28 and disengagement of the arms 28 from the item being held. In Figure 4B, a lug 66 is locked in place in the groove 68 if it is in the area 75.

Lugs 77 projecting downwardly from the housing 24 are movable in the areas 171 of the spline spacer 46. When the lugs 66 enter the groove 68, it is the lugs 77 abutting the raised areas 78 of the spline spacer 46 that stop movement of the lugs 66 in the groove 68 and prevent the lugs 66 from entering the next slot 72 in the housing 24, i.e., it is the stopping of the lugs 77 that prevents the central mandrel 21 from unlocking from the housing 24, that is until the central mandrel's rotation is reversed (right-hand rotation) to again align the lugs 66 with a slot 72 and thereby free the lugs 66 from the groove 68.

- 11 -

Figure 7A shows a central mandrel 100 like the central mandrel 21 which is particularly suited for an embodiment of the present invention in which a marine swivel is used as described herein. In such an application a system according to the present invention may be like the systems of Figs. 1 and 2, but without any mud motor or safety clamps. With such an apparatus, a marine swivel is disposed on top of the bonnet 23 and the marine swivel preferably has a lower beveled edge that corresponds to a top beveled edge of the bonnet 23. The system 10, 50 is interconnected with a drill string that passes through the marine swivel and the drill string rotates the system 10, 50 from above.

Figure 8A shows a central mandrel 150 for use in a system (as shown in Figures 1 and 2 with a mud motor 12. Appropriate subs (not shown) are connected above and below the central mandrel 150 so the resulting combination looks like the mandrel of Figure 7A, but the inner diameter of the mandrel 150 is sized to accommodate the power shaft of the mud motor 12. The lugs 166 correspond to the lugs 66 of the mandrel of Figure 3A. A groove 181 in the housing 24 accommodates a seal (not shown) and/or one or more removable shims of different dimensions so that the housing 24 can fit over a variety of wellheads and can accommodate each of them.

CLAIMS:

1. An apparatus for facilitating retrieval of an item from a well, said apparatus
5 comprising a mandrel (21) which is movable to releasably engage the item, and locking
means (66, 68) for locking the mandrel (21) with respect to the item, characterised in
that gripping means (24, 28) are mounted on the mandrel (21) for releasably gripping
the item, and the mandrel (21) is movable relative to said gripping means (24, 28)
between a first position in which said gripping means (24, 28) is able to release the item
10 and a second position in which said gripping means (24, 28) is prevented from releasing
the item, said locking means (66, 68) being actuatable when the mandrel (21) is in the
second position to prevent movement of the mandrel (21) relative to said gripping
means (24, 28).
- 15 2. An apparatus as claimed in claim 1, wherein said locking means (66, 68) is
actuatable by movement of the mandrel (21).
3. An apparatus as claimed in claim 2, wherein one of the mandrel (21) and said
gripping means (24, 28) comprises at least one lug (66) movably arranged in a channel
20 (68) in the other of the mandrel (21) and said gripping means (28), such that one of said
lug (66) and said channel (68) is movable from a first position in which said gripping
means (28) is able to release the item to a second position in which said gripping means
(28) is prevented from releasing the item.
- 25 4. An apparatus as claimed in claim 3, wherein one of said lug (66) and said
channel (68) is movable from the first position to the second position on rotation of the
mandrel (21) with respect to said gripping means (24, 28).
5. An apparatus as claimed in claim 3, wherein one of said lug (66) and said
30 channel (68) is movable from the first position to the second position by longitudinal
movement of the mandrel (21) with respect to said gripping means (24, 28).

13

6. An apparatus as claimed in claim 3, wherein one of said lug (66) and said channel (68) is movable from the first position to the second position by a combination of rotation of the mandrel (21) and longitudinal movement of the mandrel (21) with respect to said gripping means (24, 28).
- 5
7. An apparatus as claimed in any preceding claim, wherein said gripping means comprises a housing (24) and at least one arm (28) movable thereon.
8. An apparatus as claimed in claim 7, wherein the arm (28) is movable about a pivot (26) on the housing (24).
- 10
9. An apparatus as claimed in claim 7 or 8, wherein the mandrel (21) incorporates a shoulder (61) capable of use moving the arm (28) into engagement with the item.
- 15
10. A system comprising a cutting tool (30) and an apparatus as claimed in any preceding claim.
11. A system as claimed in claim 10, further comprising a mud motor (12).
- 20
12. A system for facilitating retrieval of an item from a well, the system comprising a grapple (20), and a cutting tool (30) arranged therebelow, characterised in that said system further comprises expulsion means (122, 154) for expelling fluid under pressure disposed above said cutting tool (30).
- 25
13. A system as claimed in claim 12, said expulsion means (122, 154) is located above said cutting tool (30) and below said grapple (20).
14. A system as claimed in claim 12 or 13, further comprising a downhole motor (12) actuable by a fluid, wherein, in use, at least part of the fluid is expelled through said means (122).
- 30
15. A system as claimed in claim 12, 13 or 14, wherein said expulsion means (122, 154) comprises at least one hole.

M 28.01.00

14

16. A system as claimed in claim 15, wherein said at least one hole is located in a rotatable part of said mud motor.

5 17. A system as claimed in claim 15, wherein said hole (154) is located in the housing (23) of the grapple (20).

18. A system as claimed in any of claims 12 to 17, wherein said expulsion means (122, 154) is located in a sub (44).

10

19. A method for facilitating retrieval of an item from a well using a system as claimed in any of claims 12 to 17, comprising the steps of inserting at least part of said system into a tubular, rotating said cutting tool, at least part of said cutting tool engaging said tubular to cut said tubular, which cutting action generates swarf, characterised in that said method comprises the step of expelling fluid above said cutting tool for preventing said swarf reaching said grapple.

15

20. An apparatus for facilitating retrieval of an item from a well, said apparatus comprising at least one arm (28), characterised in that said at least one arm (28) comprises at least one groove (59, 59a) for receiving debris that might otherwise inhibit the operation of said apparatus.

20

FIG. 1

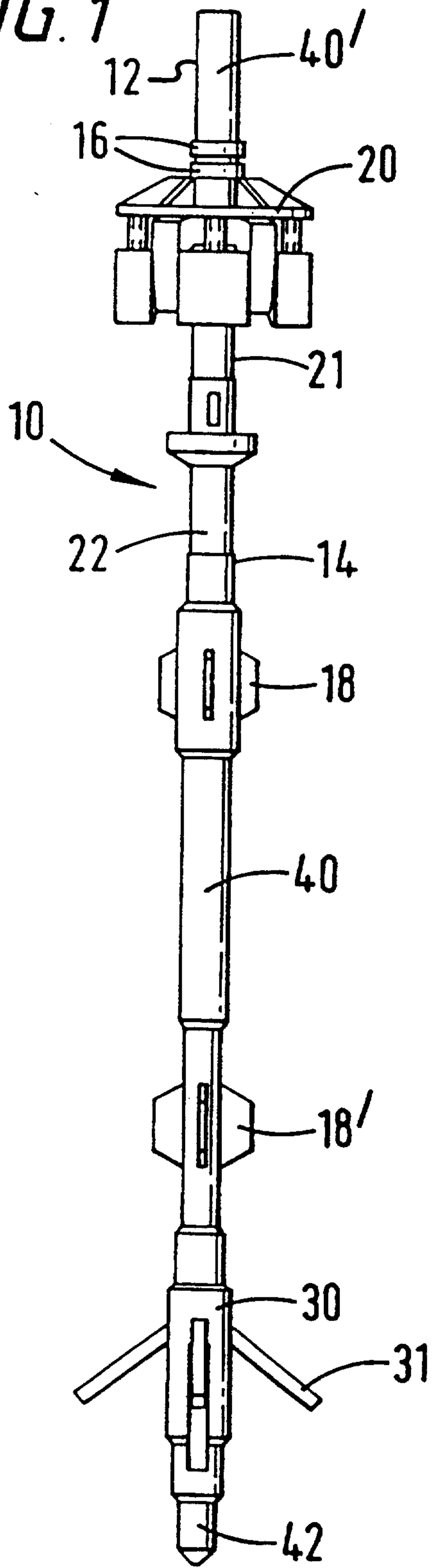
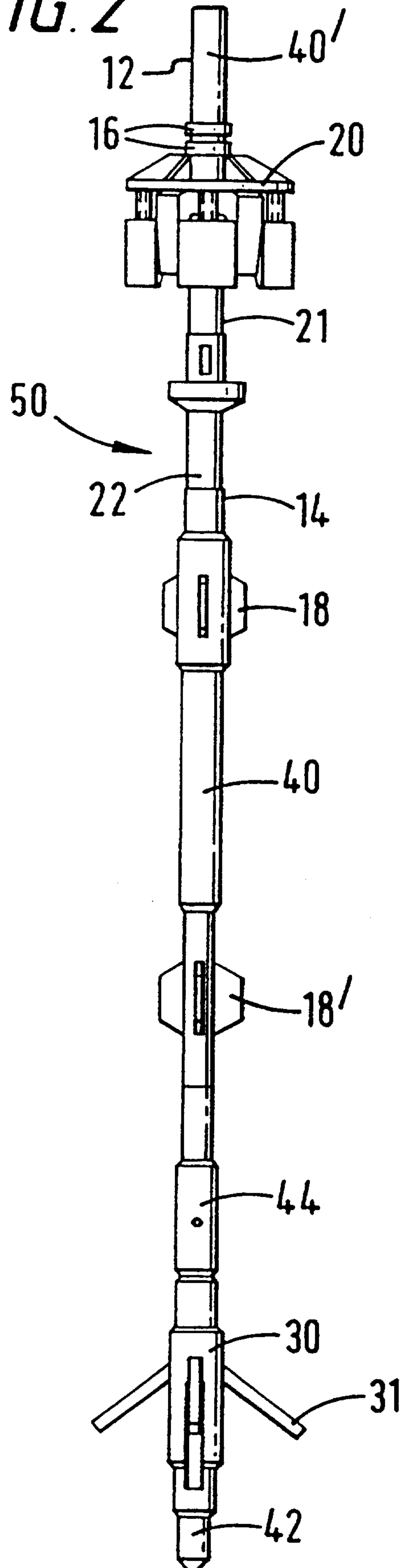

FIG. 2



Marks & Clerk

3/4

FIG. 3F

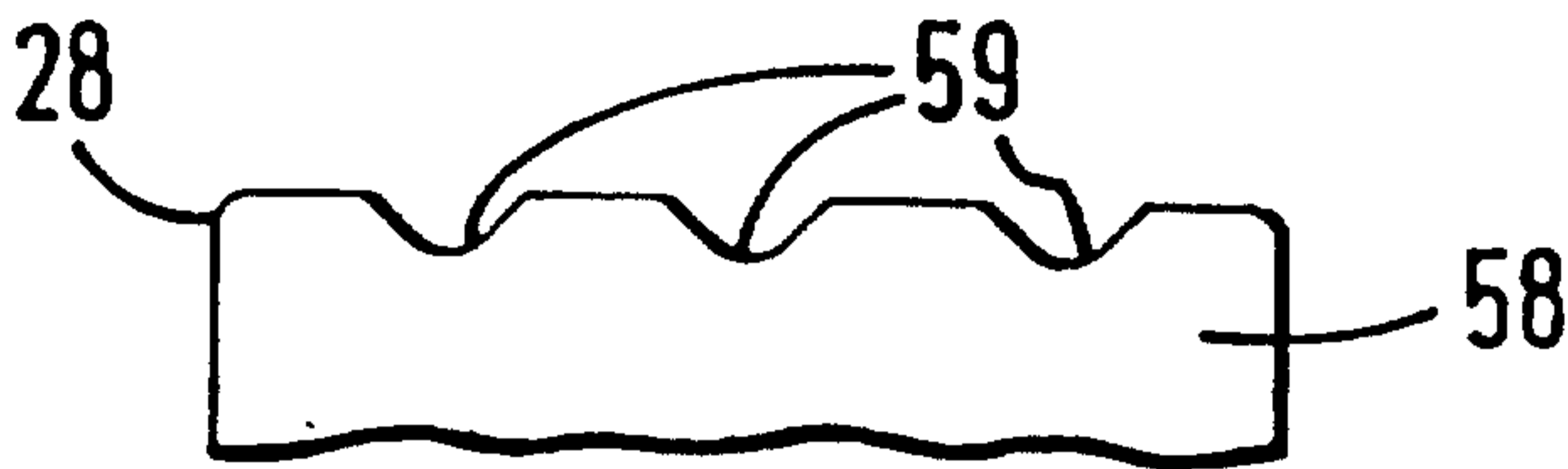

FIG. 3G

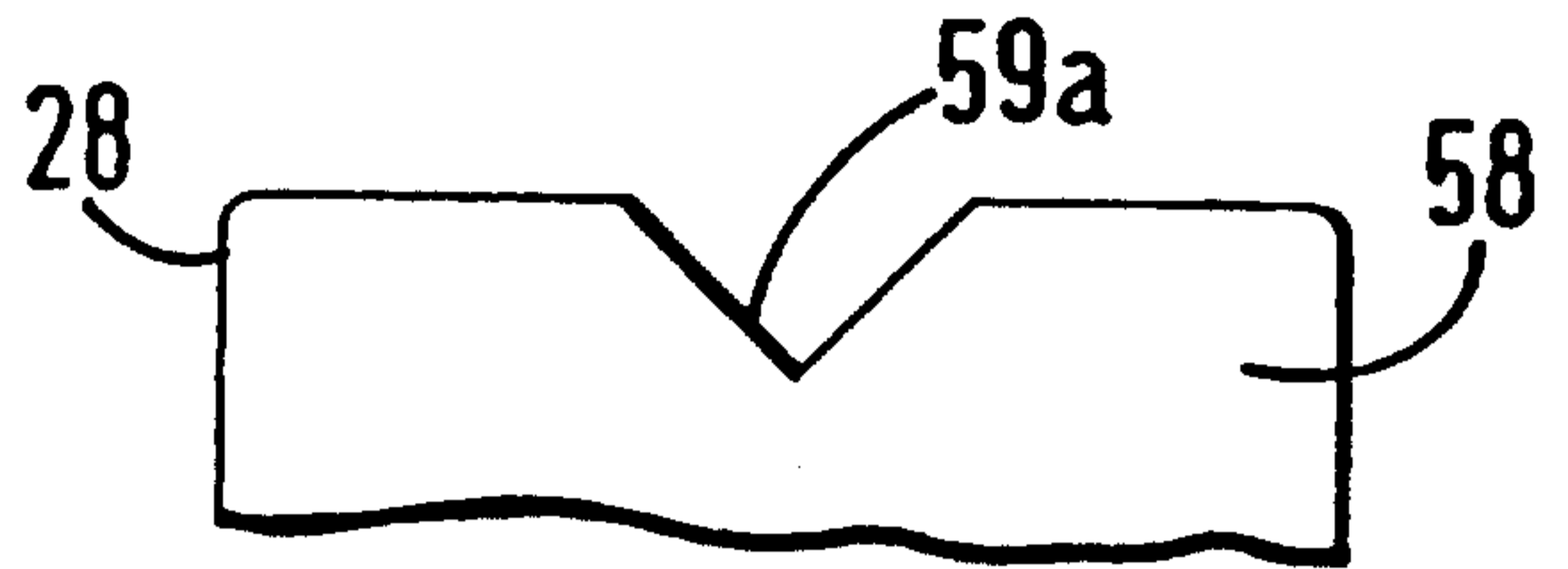

FIG. 4A

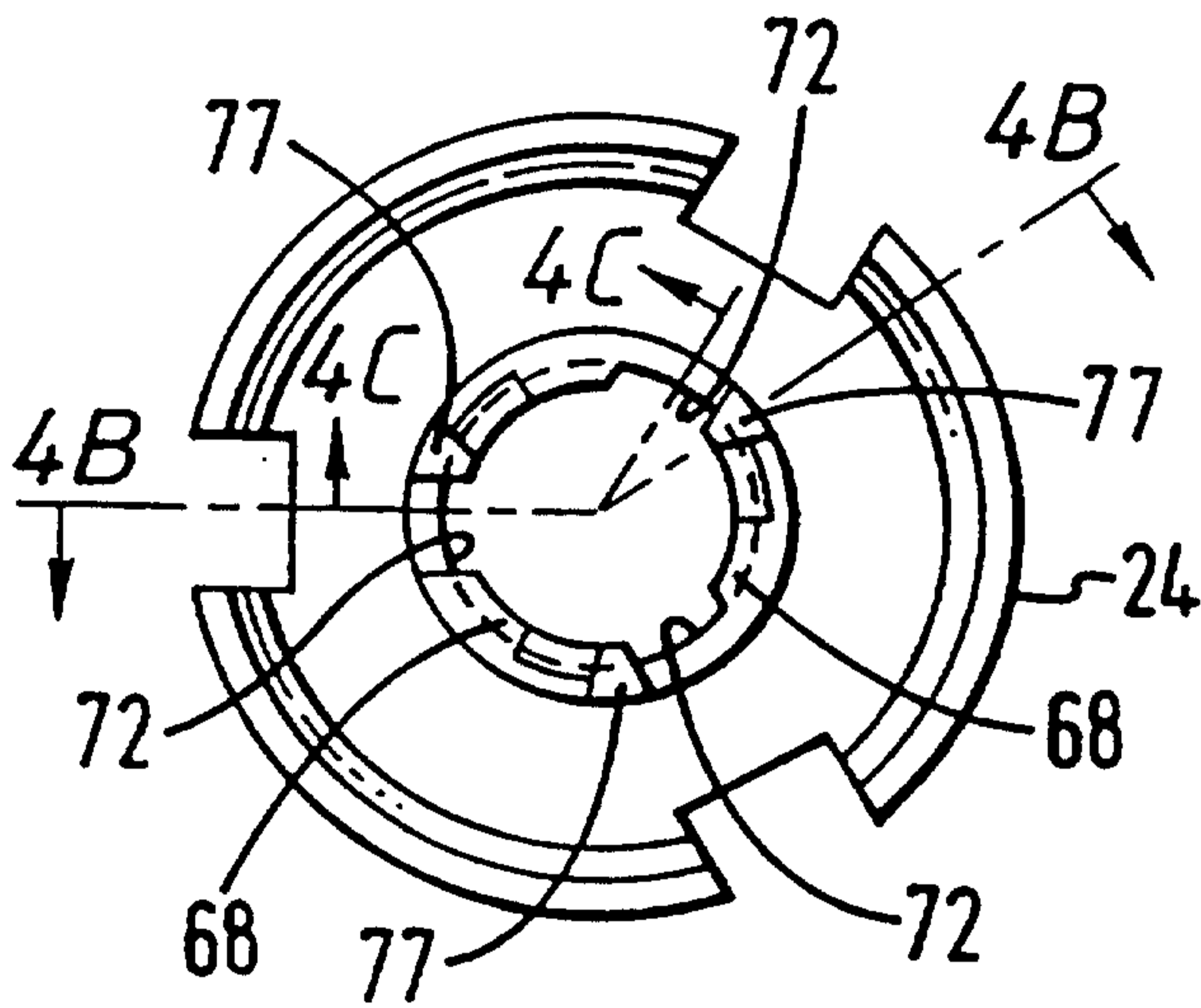

FIG. 4B

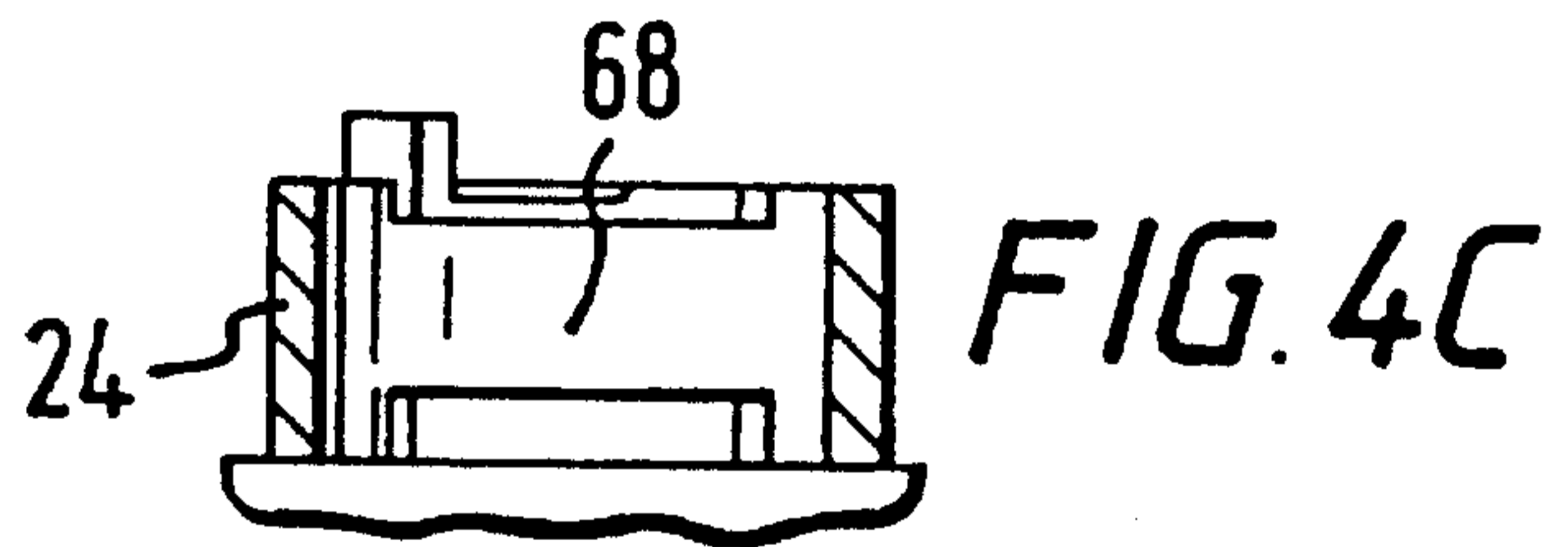
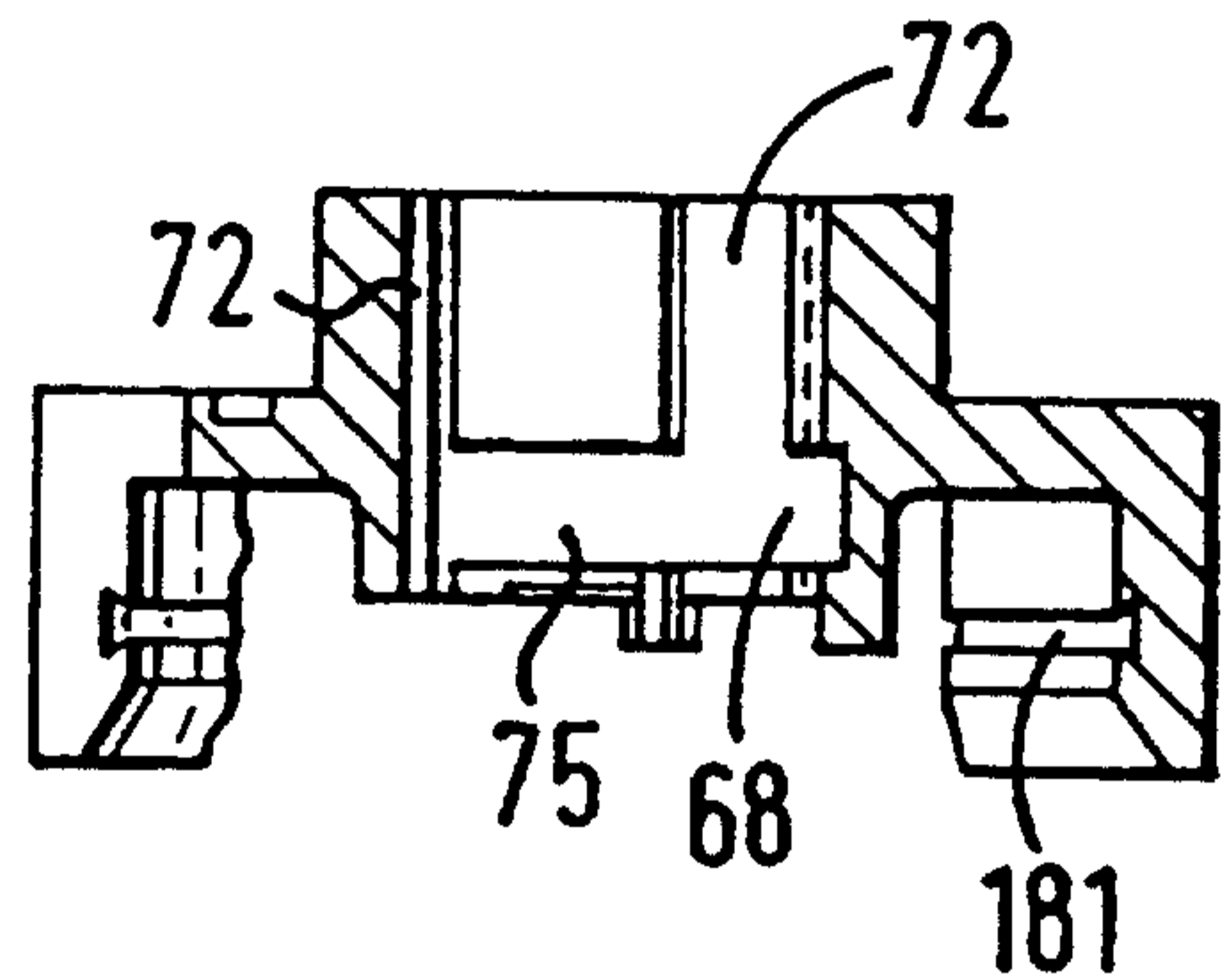

FIG. 4D

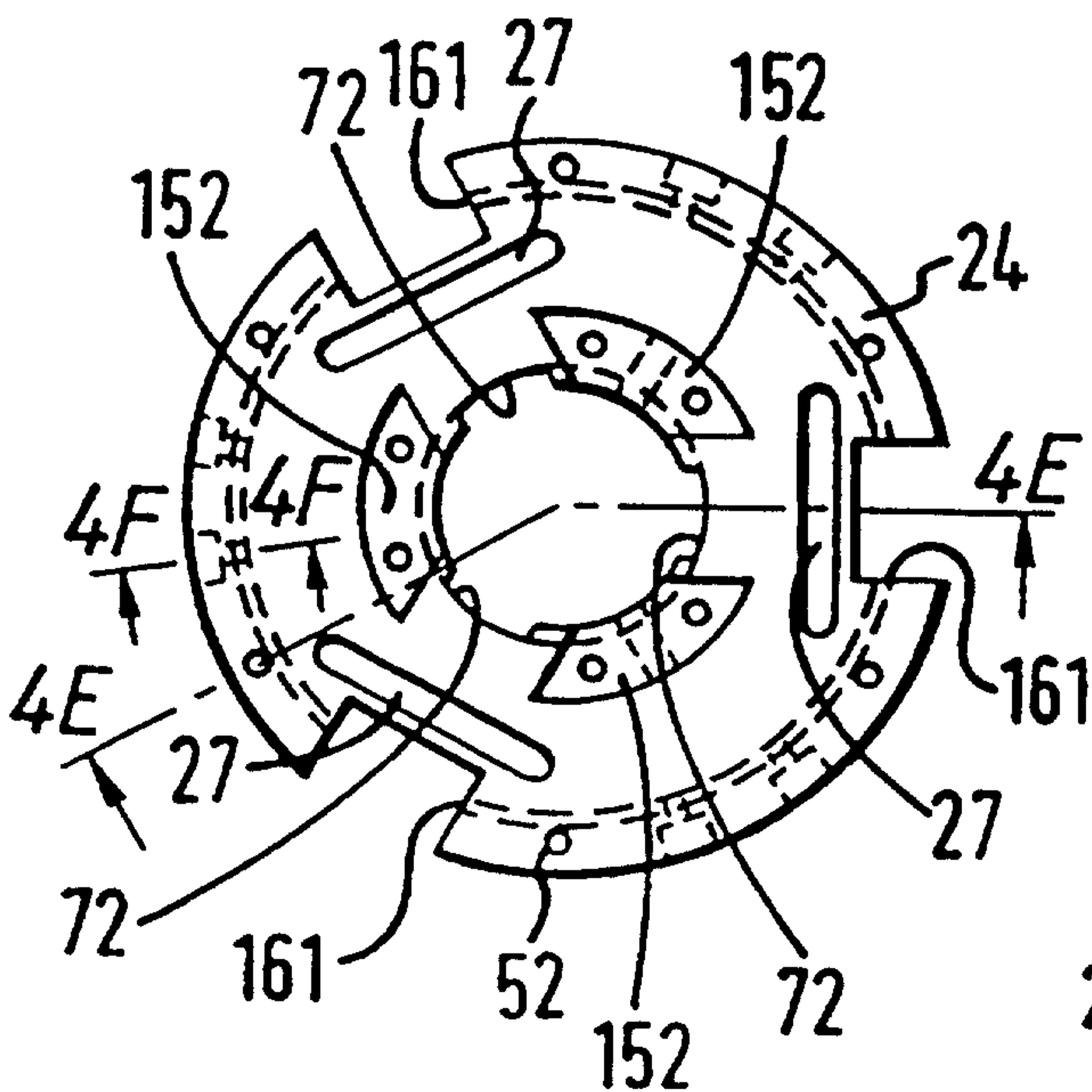
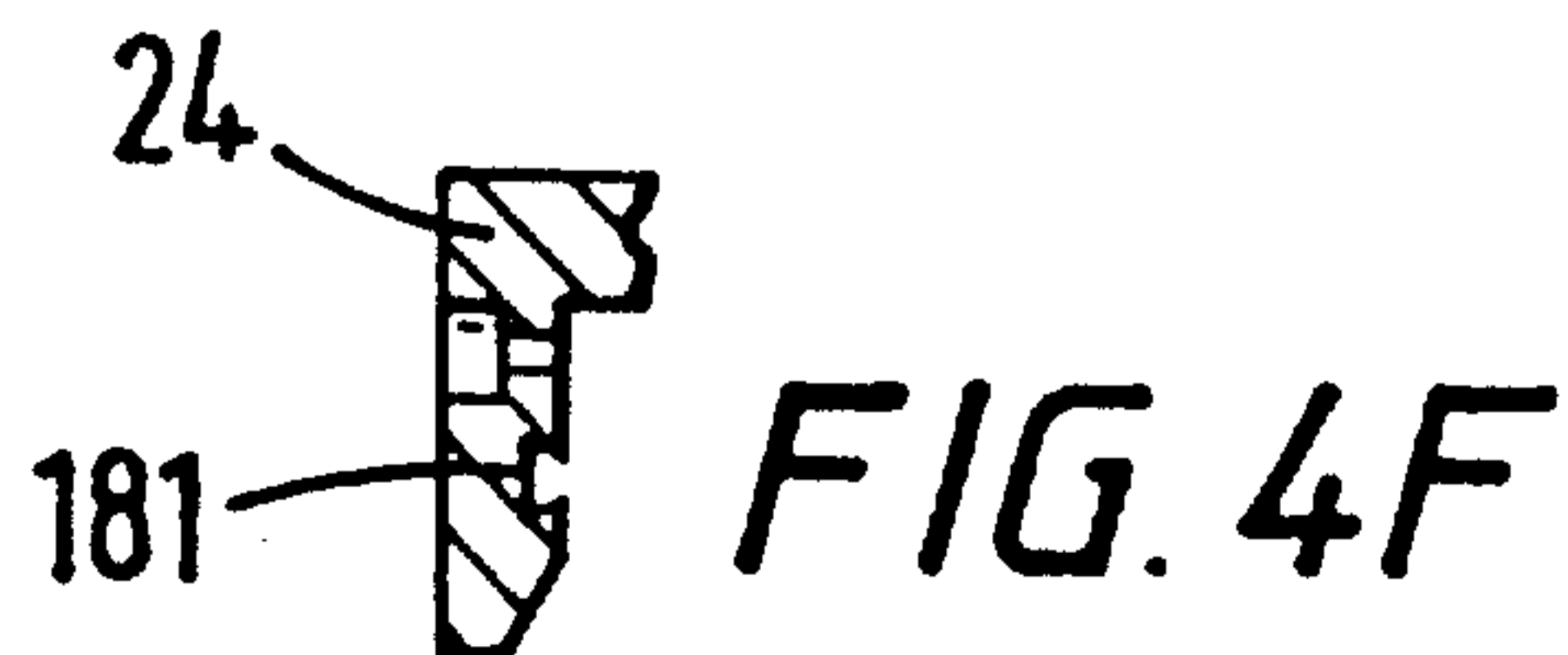
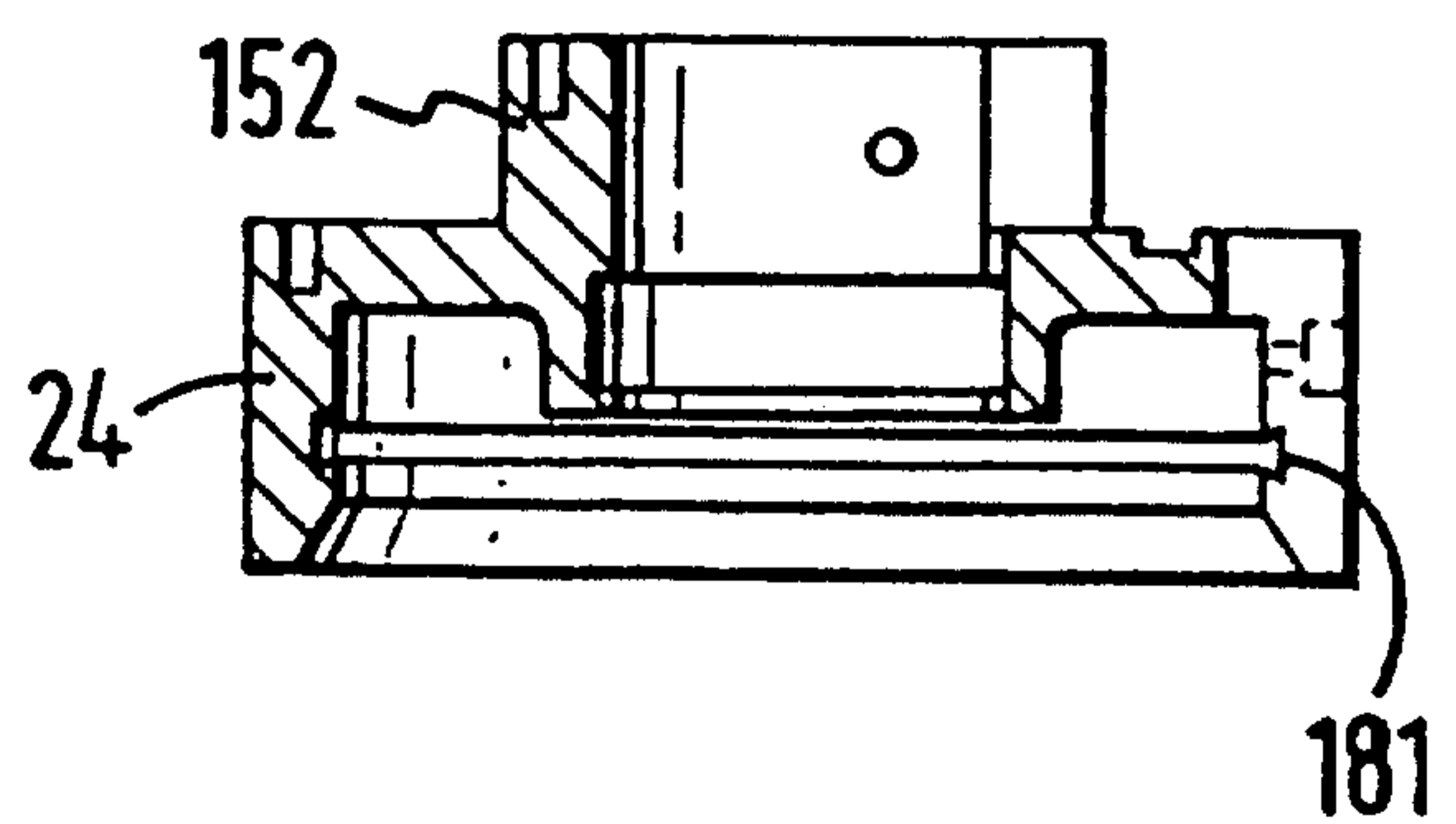

FIG. 4E



Marks & Clerk

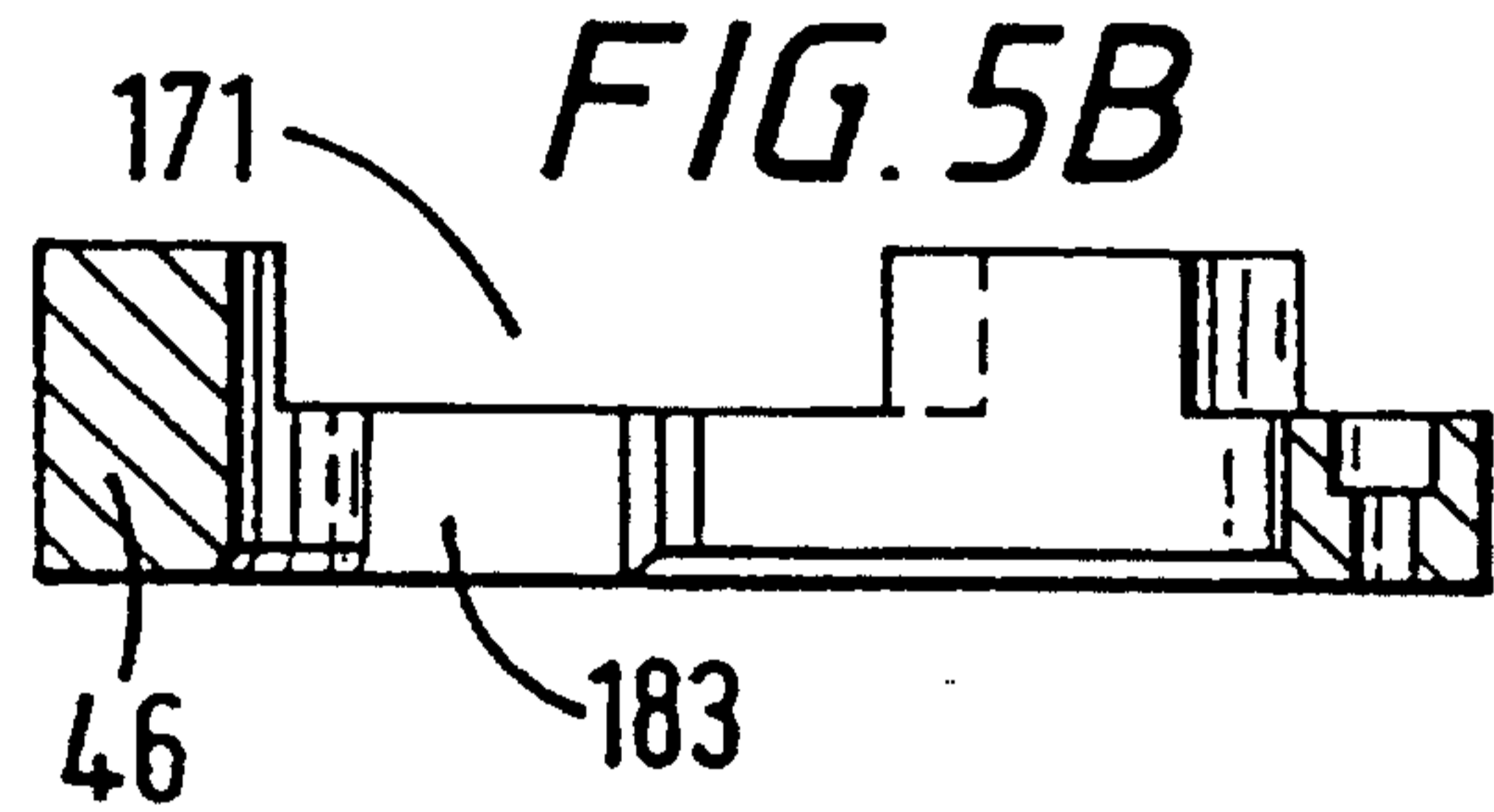
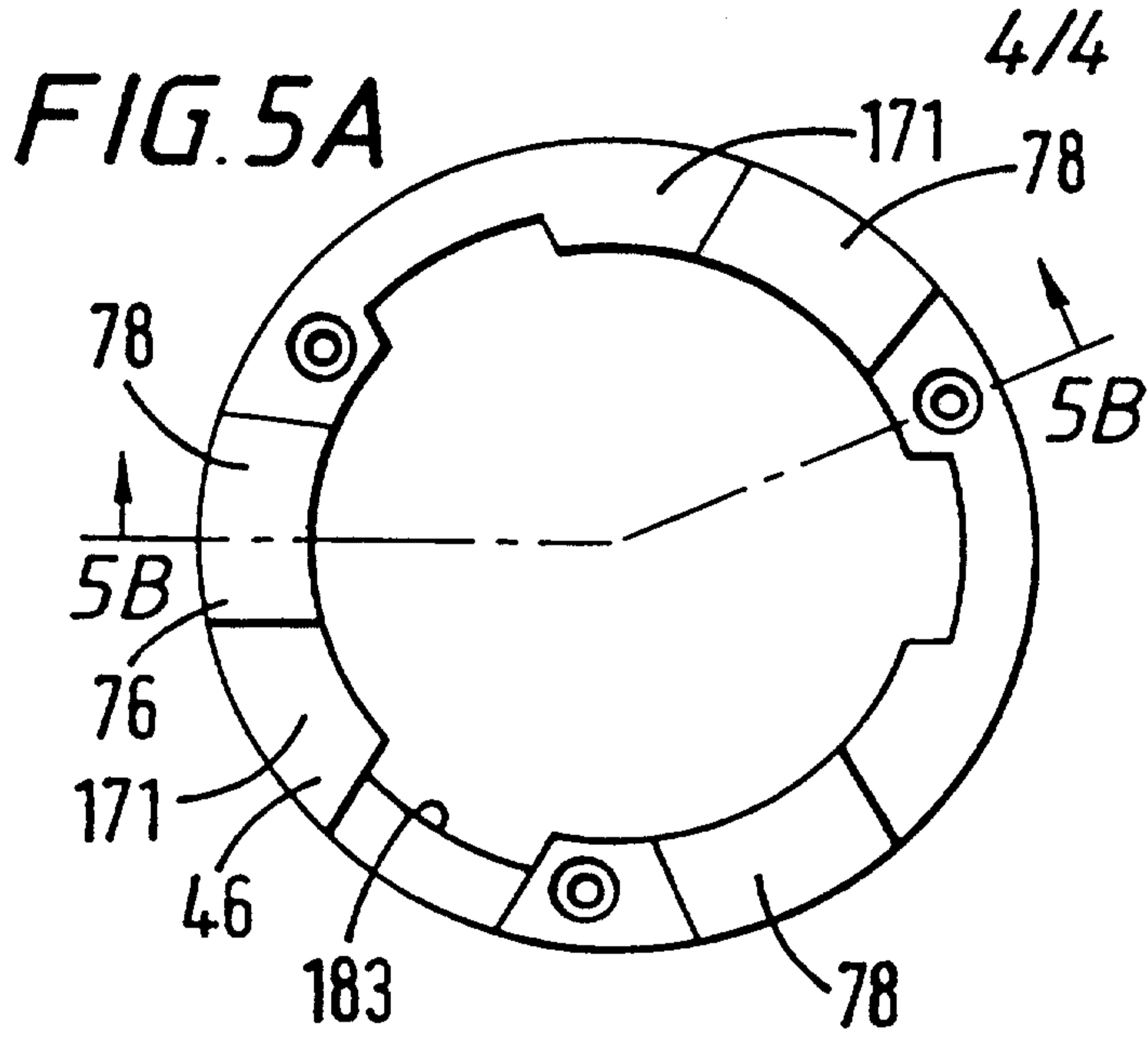

FIG. 7A

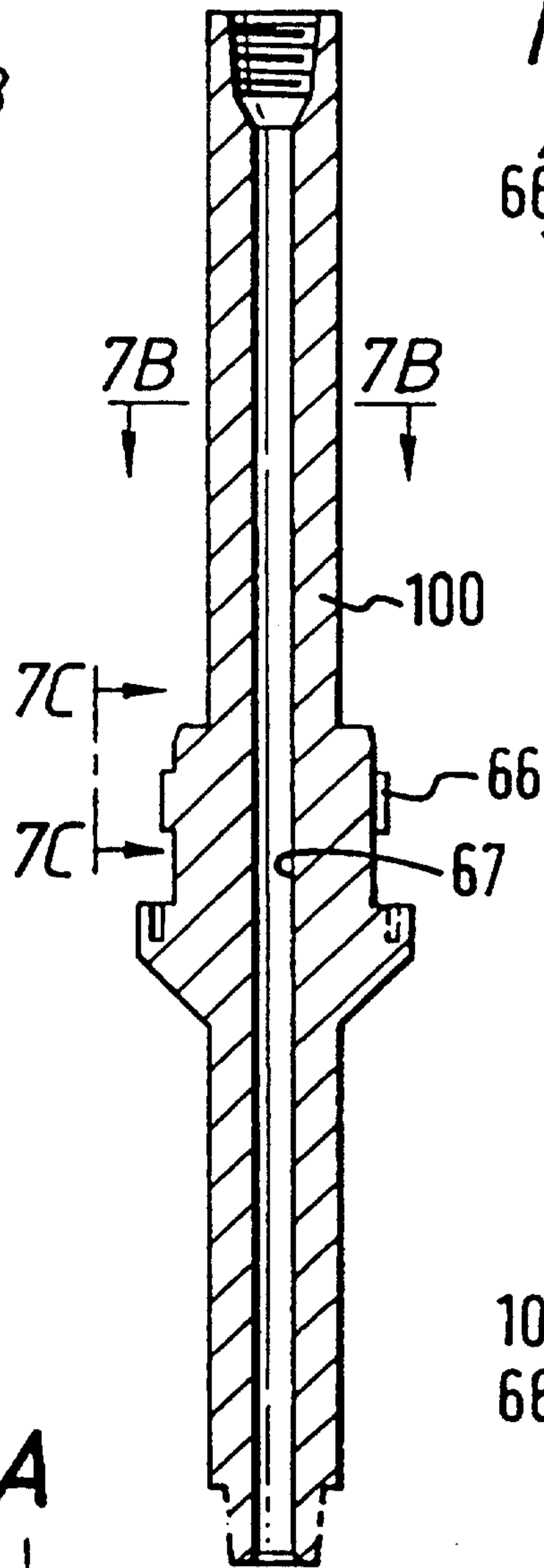

FIG. 7B

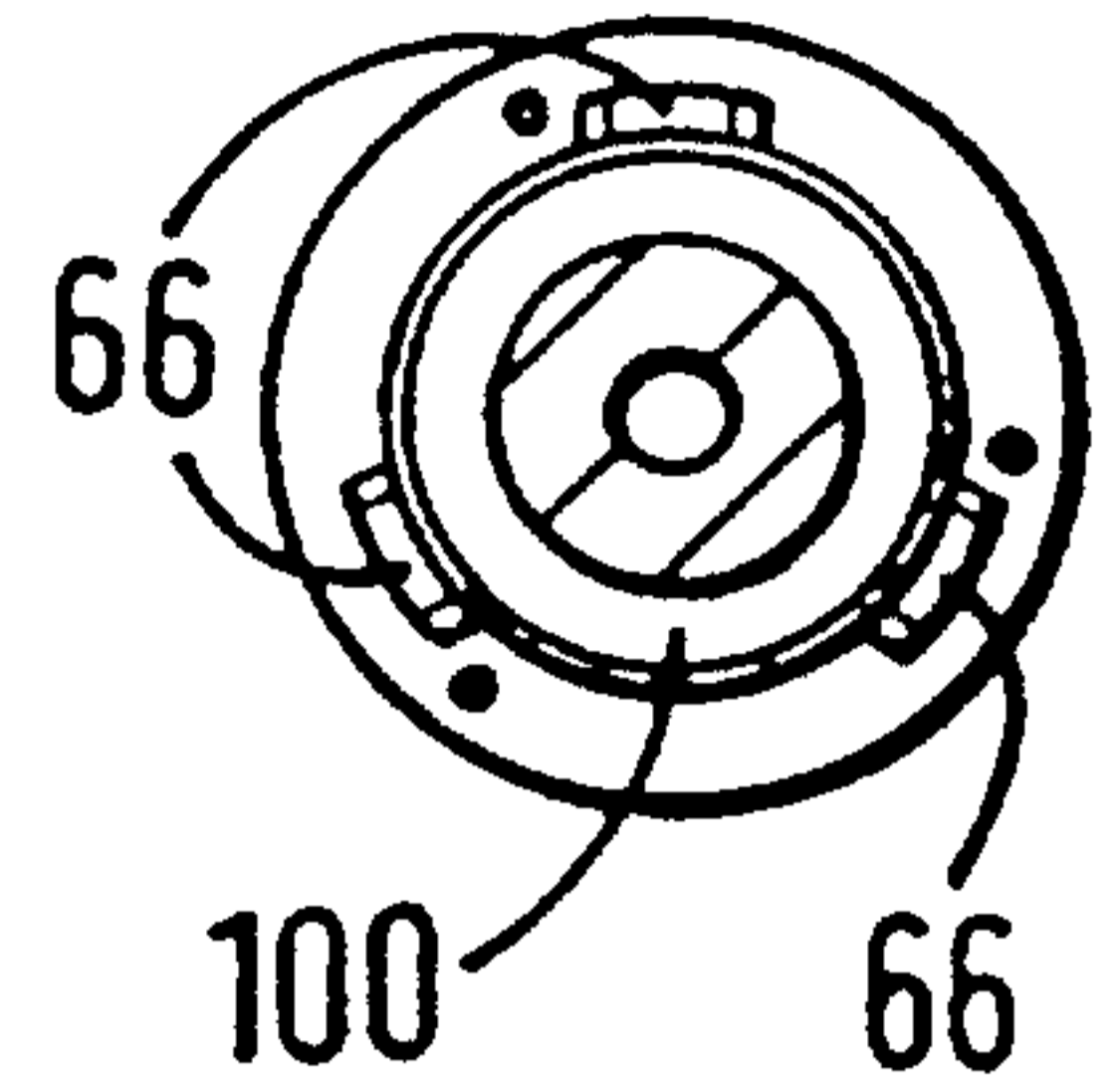

FIG. 7C

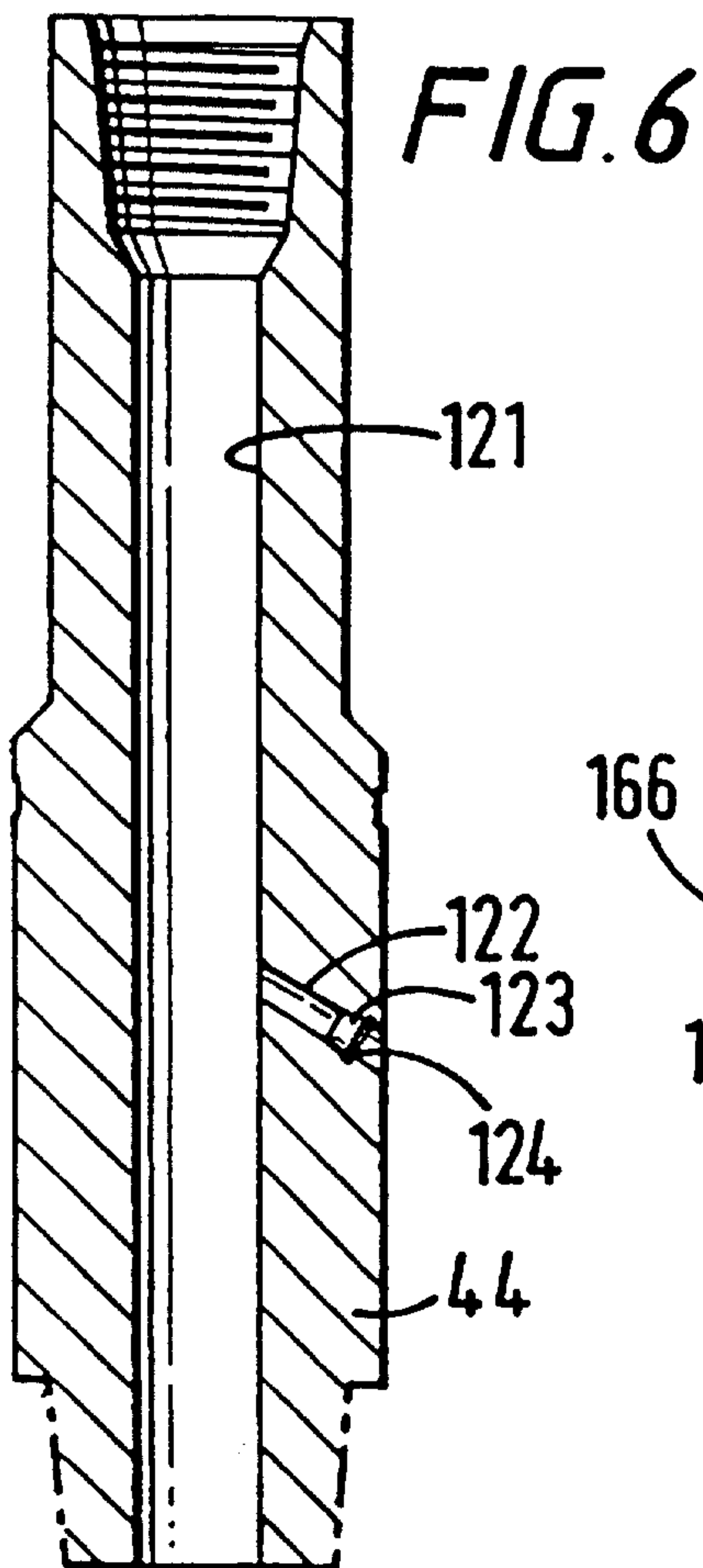
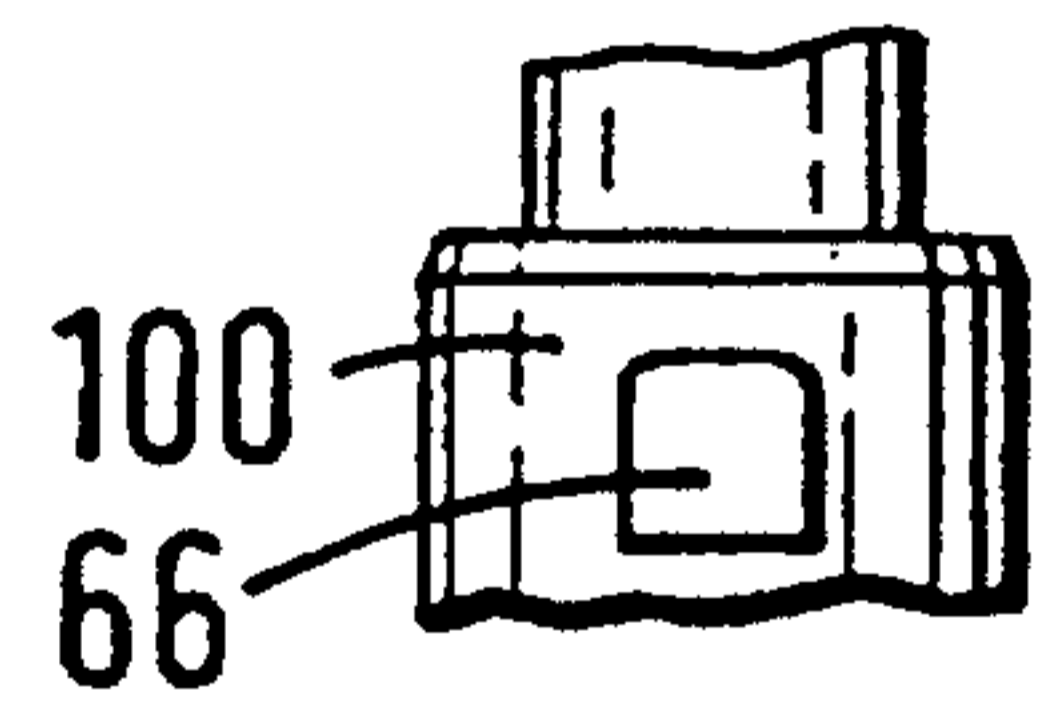

FIG. 8A

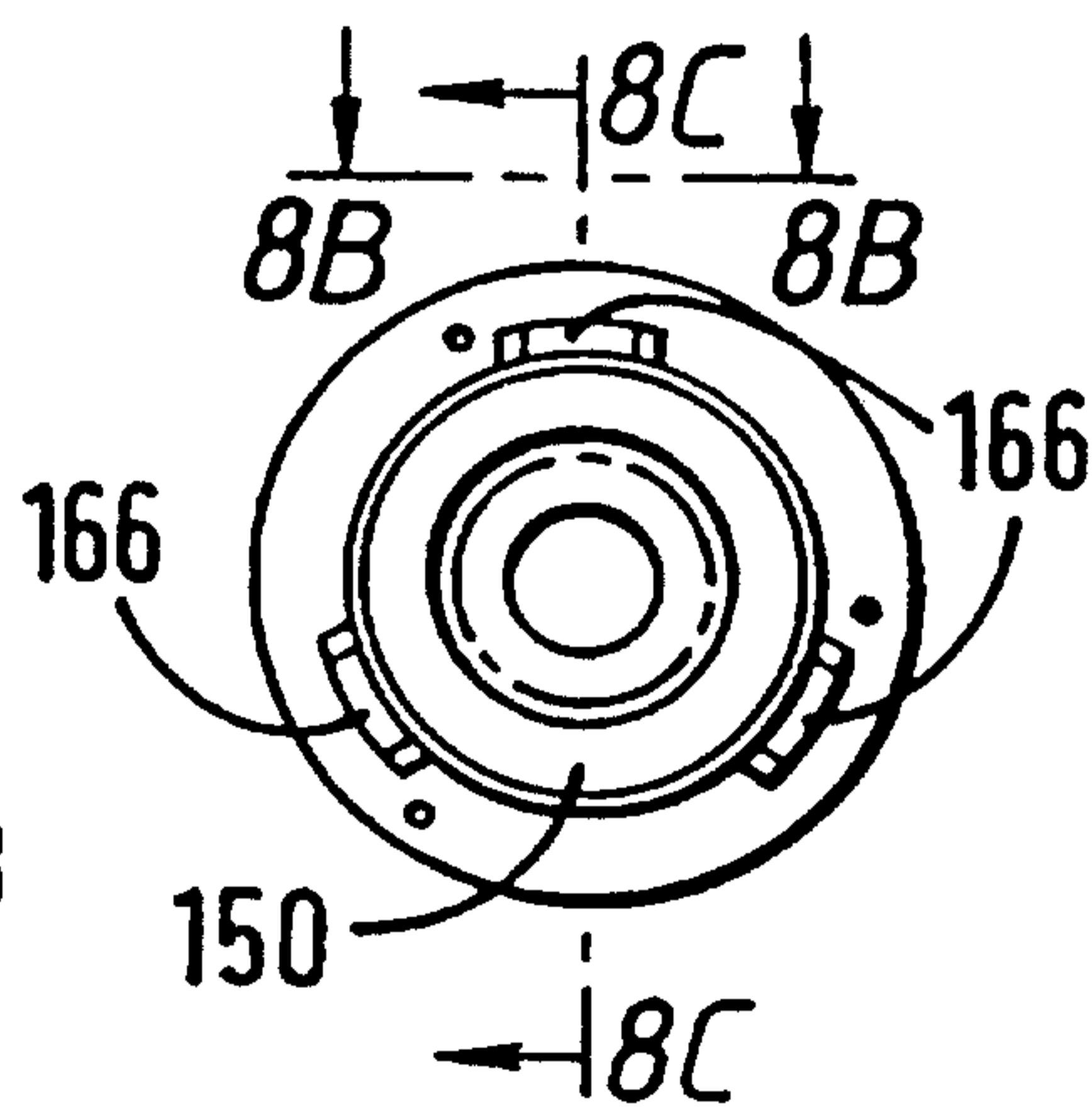

FIG. 8C

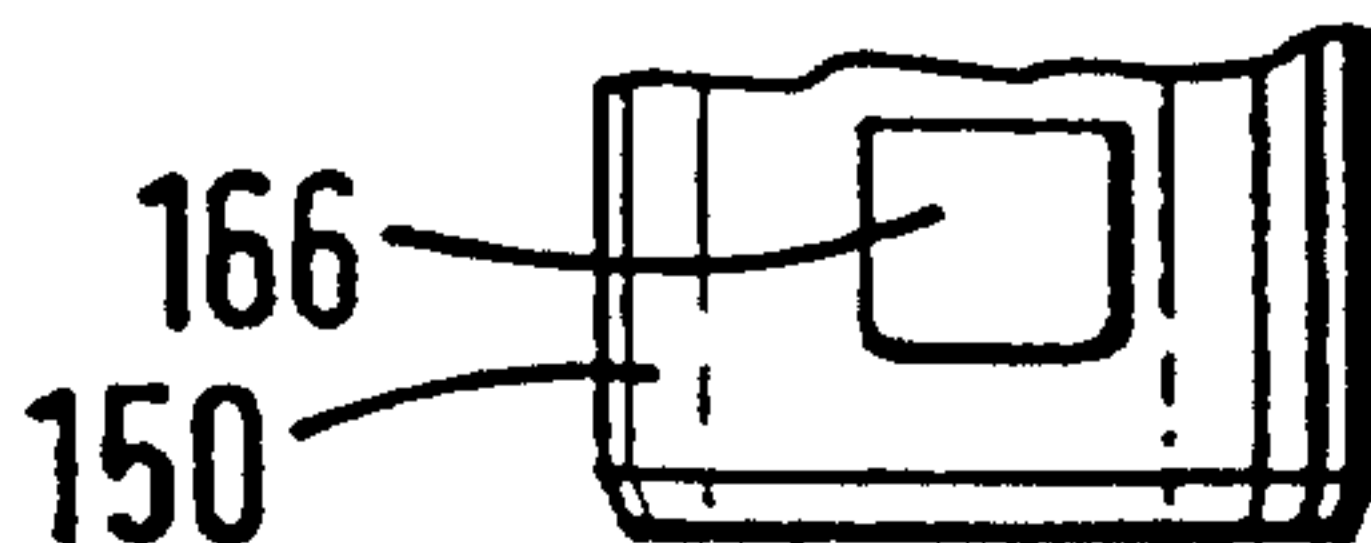
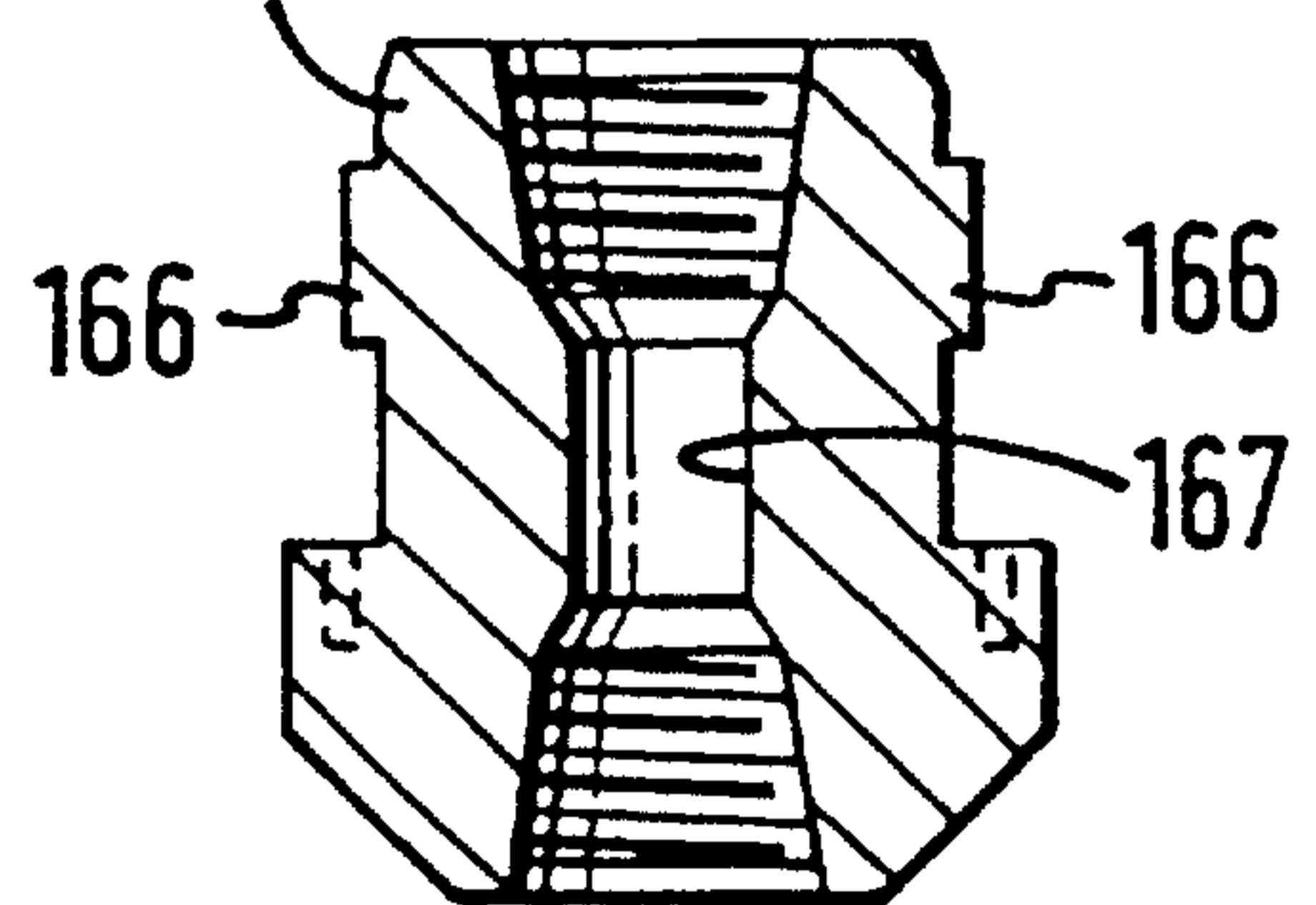

FIG. 8B

Marks & Clerk

