



(19) **United States**

(12) **Patent Application Publication**

Allen

(10) **Pub. No.: US 2008/0273669 A1**

(43) **Pub. Date: Nov. 6, 2008**

(54) **EMERGENCY NUMBER INTEGRATED INFORMATION ASSIMILATION DEVICE**

(52) **U.S. Cl. 379/45**

(76) **Inventor: Kris Allen, Watertown, NY (US)**

(57) **ABSTRACT**

Correspondence Address:
HISCOCK & BARCLAY, LLP
2000 HSBC PLAZA, 100 Chestnut Street
ROCHESTER, NY 14604-2404 (US)

An information transponding device in communication with an emergency number answering point, an ALI database and a remote storage device. The information transponding device receives ANI information from the emergency number answering point and accesses corresponding information in the ALI database and the remote storage device and assimilates the information into a readable format utilized at the emergency number answering point and transmits to the readable format to the emergency number answering point. The detailed information is updated and modified by authorized users via a secure Web portal on the World Wide Web. An automatic notification device automatically informs predetermined contacts that an emergency number was dialed from a particular line.

(21) **Appl. No.: 11/744,770**

(22) **Filed: May 4, 2007**

Publication Classification

(51) **Int. Cl. H04M 11/04 (2006.01)**

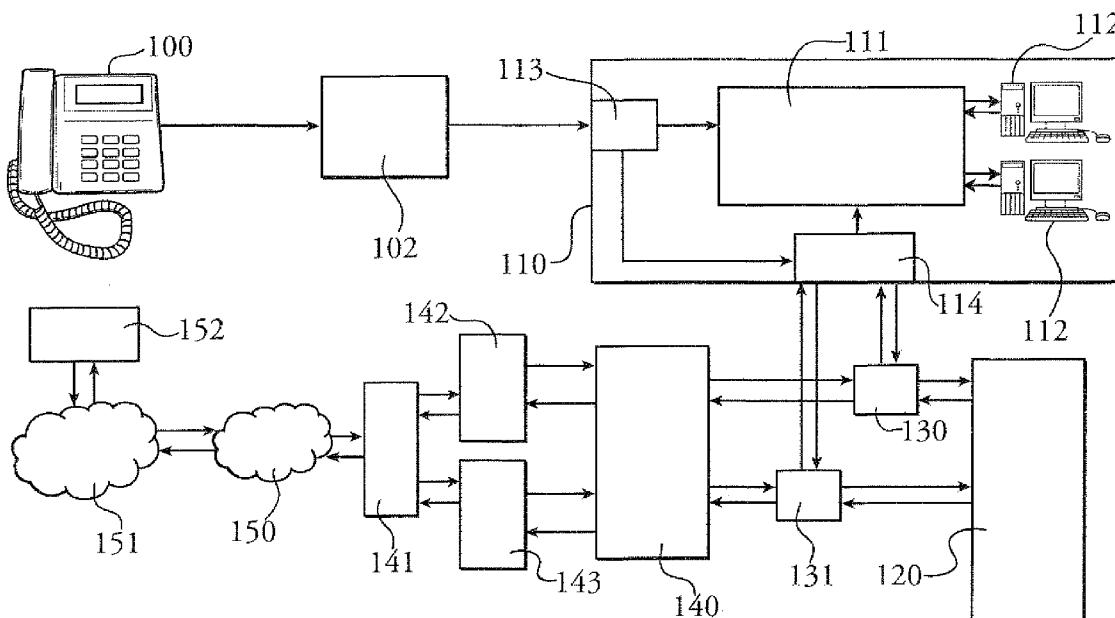

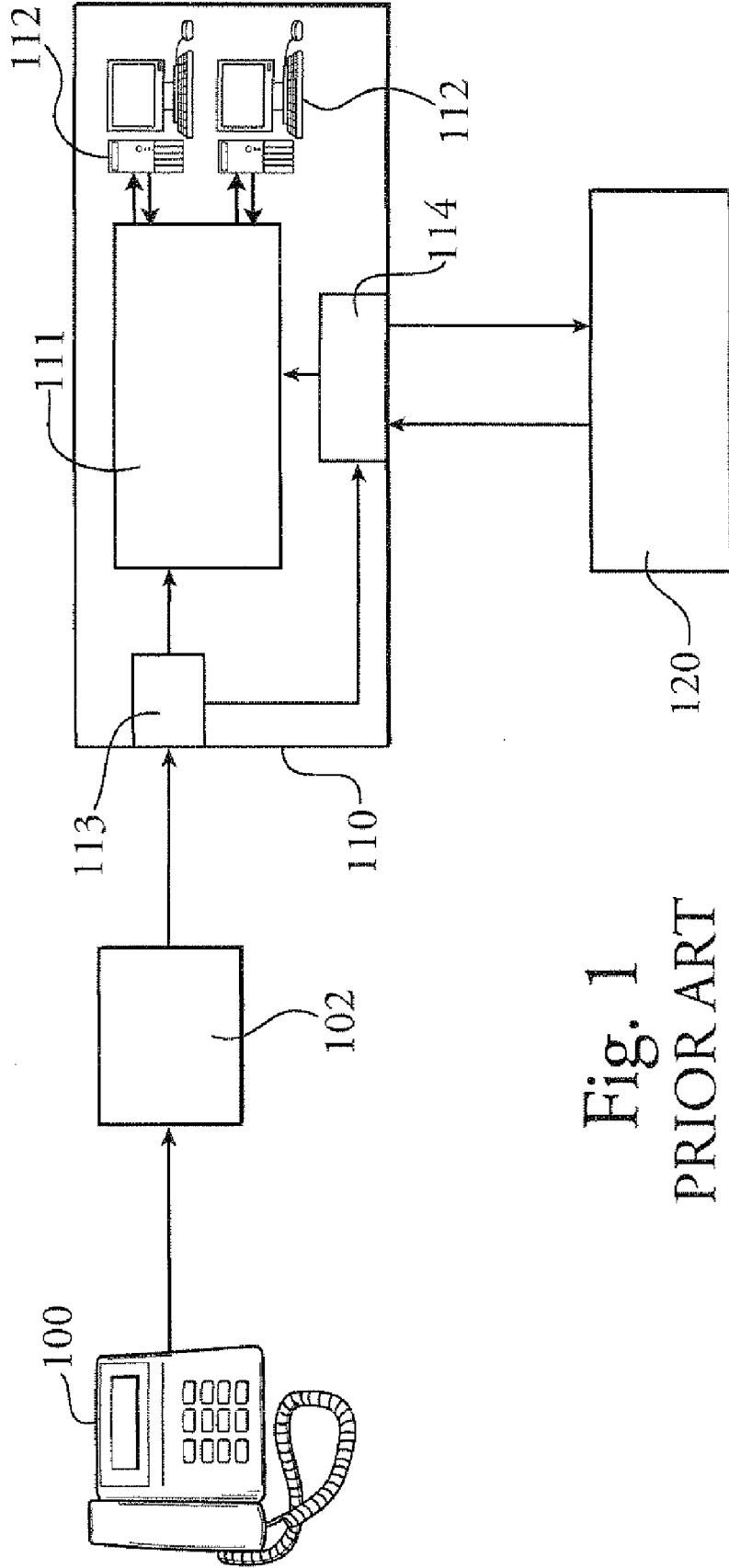

Fig. 1
PRIOR ART

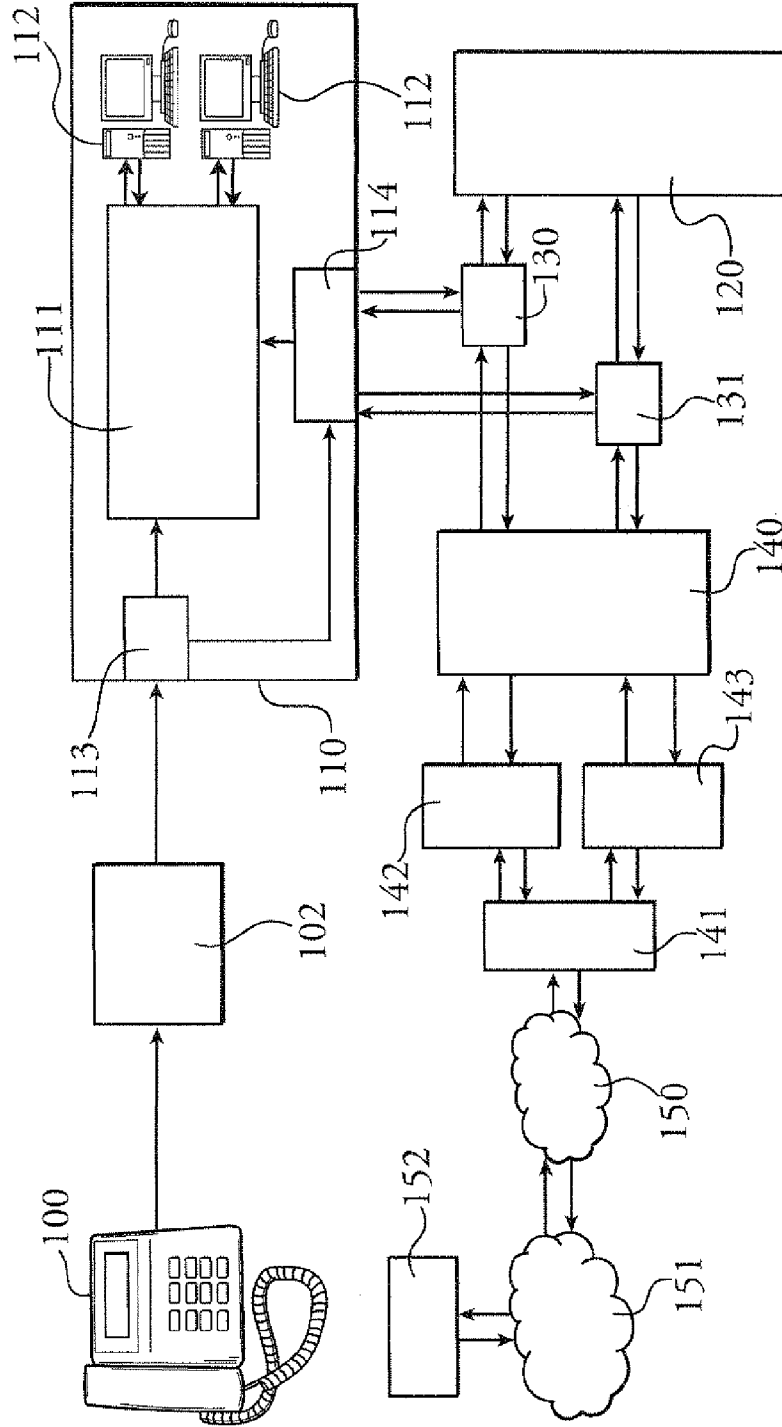

Fig. 2

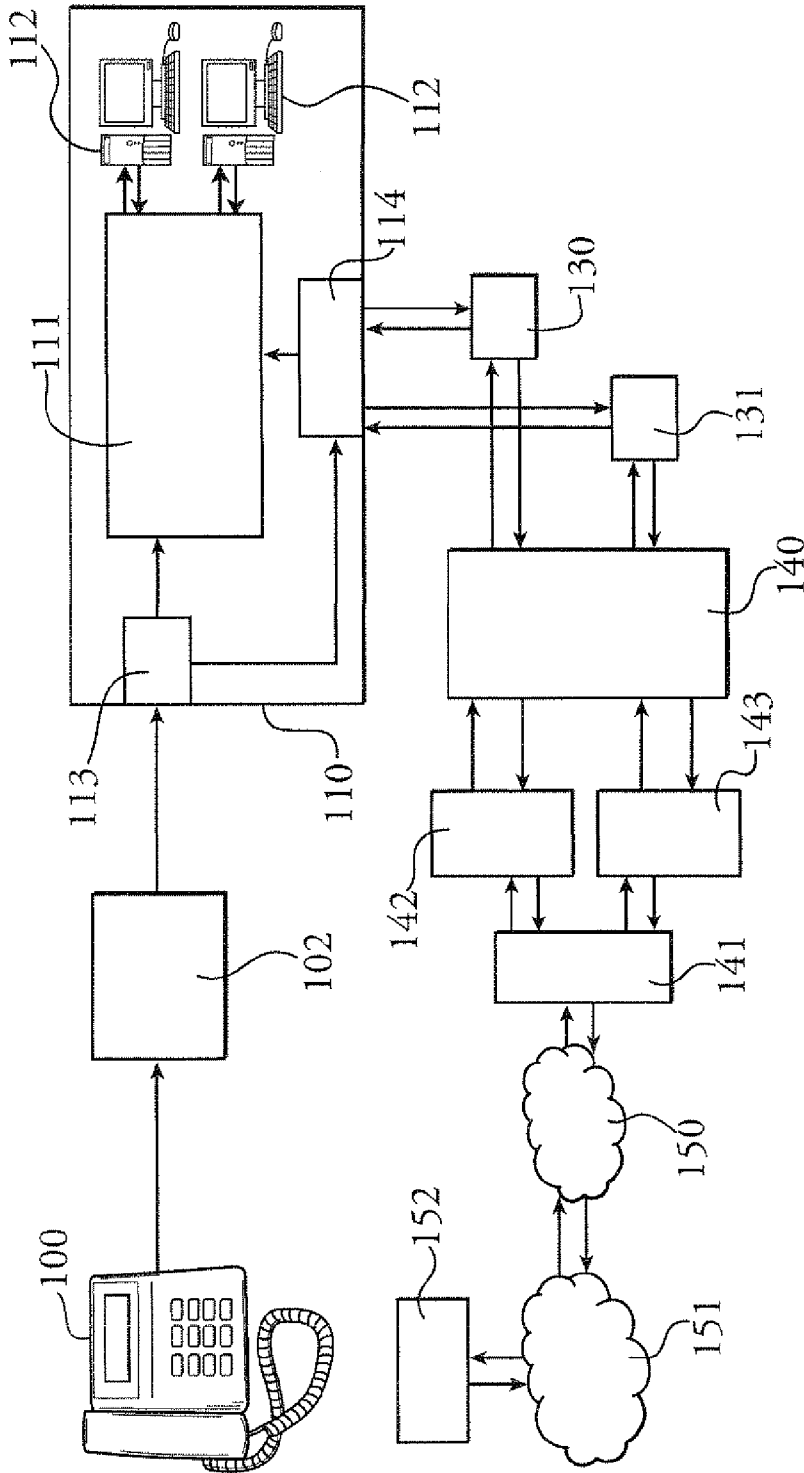

Fig. 3

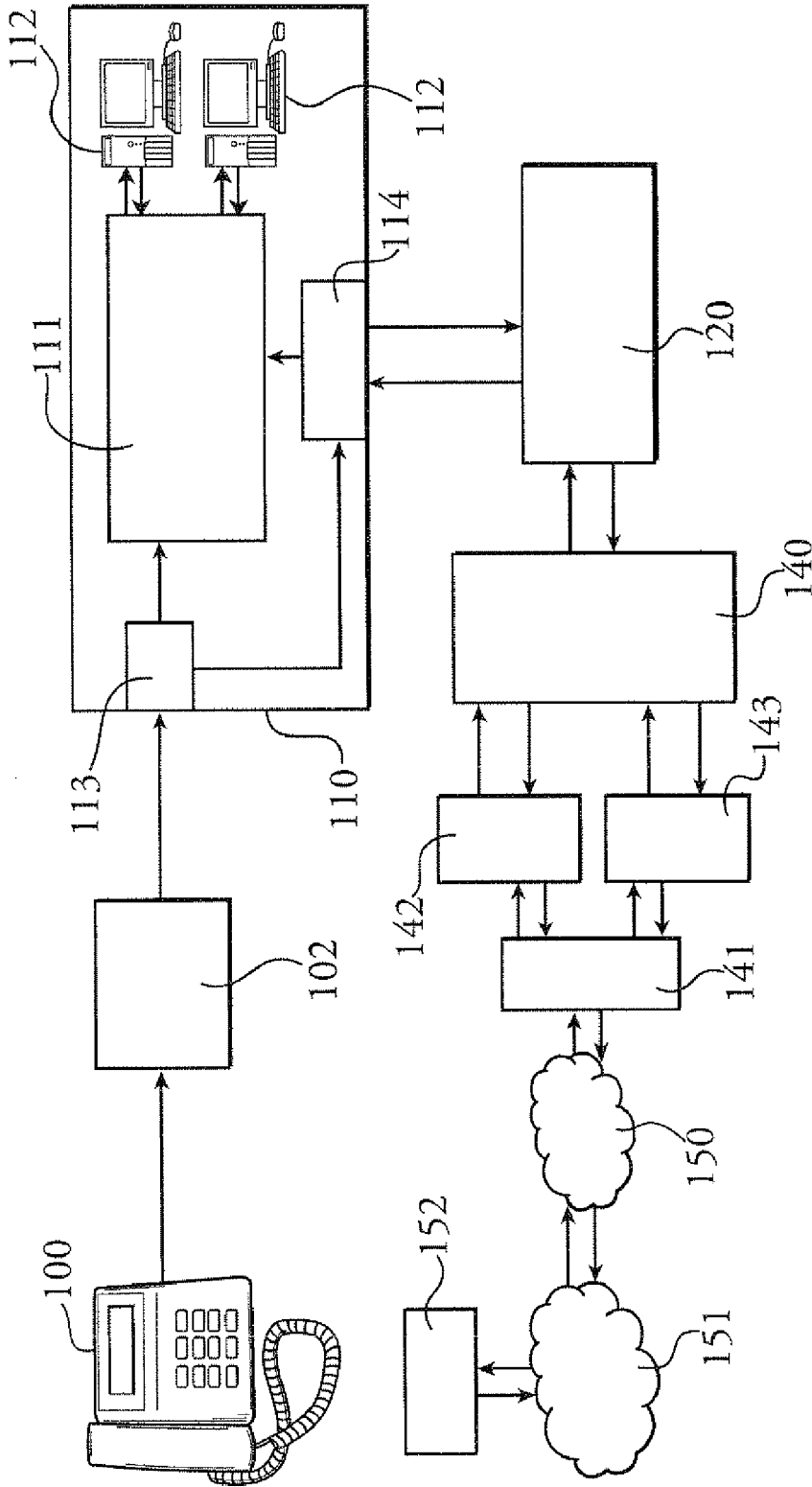

Fig. 4

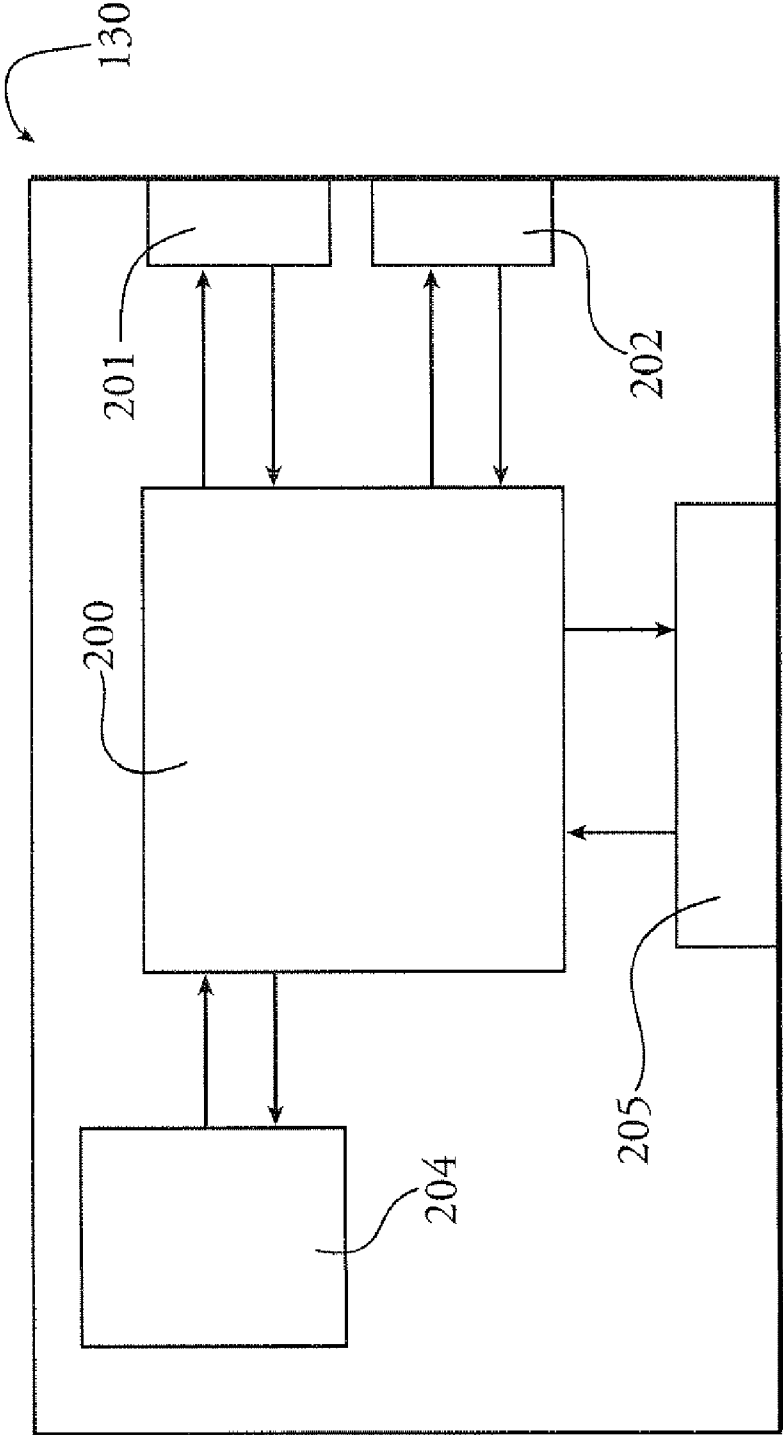

Fig. 5

EMERGENCY NUMBER INTEGRATED INFORMATION ASSIMILATION DEVICE

FIELD OF THE INVENTION

[0001] This invention relates an emergency number notification system designed to automatically transmit detailed information about the particular registered phone line to an emergency number answering point. The detailed information is relayed from the emergency number answering point to an emergency number representative to provide the representative with detailed information allowing for better assistance to the caller. This invention also relates to an automatic notification system designed to notify predetermined contacts that an emergency number was dialed from a particular registered phone line.

BACKGROUND OF THE INVENTION

[0002] Emergency numbers are used throughout the world allowing a user to dial a specific number from any phone to connect to an emergency number answering point (e.g., 911 in the U.S., 000 in Australia, 112 in the European Community, and 999 in the U.K. and some Caribbean islands). When an emergency number is dialed the call is routed through a switching system to the appropriate emergency number answering point (e.g., Public Safety Answering Point (“PSAP”) or Regional Public Safety Network (“RSPN”)), where the call is answered. Each emergency number answering point typically covers one or more metropolitan areas or at least one rural county. At the emergency number answering point the call taker determines the nature of the call and, if necessary, contacts the appropriate personal. The call taker can typically contact police, fire or emergency medical personal. The area covered by a single emergency number answering point typically includes several independent police departments, fire departments, and medical responders.

[0003] In enhanced systems when an emergency number is dialed Automatic Number Identification (ANI) information is transmitted along with the voice information to the emergency number answering point. A device at the emergency number answering point uses the ANI information to look up the documented street address location from the Automatic Location Information (ALI) database. The street address is displayed on the call takers display when the street address location is available.

[0004] The street address location transmitted from the ALI database for calls placed through a private branch exchange (PBX) creates obstacles. When a call is placed through a PBX the emergency number answering point in most cases, only receives the demarcation address of the trunk installed for a particular PBX. Therefore, unless the caller informs the call taker that they are calling from a particular location the call taker would only be able to dispatch personal to the demarcation address of the trunk installed for that PBX, and not to the specific location of the telephone which was used to place the call. As a result, any dispatched personal risks arriving at an incorrect location, which could be detrimental to particular situations. A PBX may be used across multiple floors, campuses, or even multiple buildings that are miles apart. Some PBX providers allow users to input the physical location of their telephone lines.

[0005] When a call is made from a mobile telephone location information is more difficult to ascertain. As the phone is

mobile the call may originate from a location distinct from the billing address. Therefore, additional methods are needed to determine the location of the call. In the U.S. new mobile phones are required to provide their latitude and longitude to the emergency number answering point in the event of an emergency number call. The mobile phone carriers may choose whether to implement transmit this data via GPS chips in each phone, or via triangulation between cell towers. Due to the limitations in technology of the mobile phones, cell phone towers, and emergency number answering point equipment, a mobile caller’s geographical information may not always be available to the emergency number answering point.

[0006] Regardless of the type of phone that originates a call to an emergency number (residential, PBX line, mobile, or voice over internet protocol (hereinafter “IP”)), at most only location information is displayed at the emergency number answering point. Furthermore, the current systems lack the ability to automatically notify predetermined contacts that an emergency number was initiated from a particular line.

[0007] U.S. Pat. No. 5,805,670 issued to Pons et al. on Sep. 8, 1998 is directed to a private notification system that provides detailed information about a subscriber to a private command center when a subscriber dials 9-1-1. The command center personnel can then contact those persons pre-selected by the subscriber of an emergency. The call center personal must physically notify those persons pre-selected by the subscriber after receiving notice that a subscriber dialed 9-1-1. This is inefficient as automated systems more effectively communicate notices. The private notification system can further provide detailed information about a particular subscriber. However, this is done through a private communication bridge requiring an additional connection and software at the emergency number answering point.

[0008] Therefore, automatic notification is desired. There is a need for an efficient means for automatically notifying pre-determined persons that an emergency number has been dialed from a particular line.

[0009] Further, a device that can automatically transmit detailed information about the subscriber through existing systems is desired. There is a need to automatically provide additional information to an emergency number answering point without significantly modifying the existing systems.

SUMMARY OF THE INVENTION

[0010] The invention comprises, in one form thereof an information transponding device in communication with an emergency number answering point, an ALI database and a remote storage device. The information transponding device receives ANI information from the emergency number answering point and accesses the corresponding information in the ALI database and the remote storage device. The information transponding device then merges the information into assimilated information and transmits to the emergency number answering point.

[0011] Additionally, the invention includes an automatic notification device to inform a predetermined list of persons that an emergency number was dialed from a particular line. The automatic notification device can be selected to generate a pre-recorded phone message, and e-mail, a text message or a page. The subscriber can update the list of predetermined persons through a Web portal and select the method or methods of contact.

[0012] In another form, the invention includes a system for allowing an authorized user to update the information that is transmitted to the emergency number answering point through a Web portal.

[0013] An advantage of the present invention is that the information transponding device can be installed with current systems without the need for additional connections or software at the emergency number answering point.

[0014] A further advantage of the present invention is that automatic notification can be sent to multiple persons in a variety of mediums.

[0015] An even further advantage of the present invention is that an authorized user can update the information that is transmitted to the emergency number answering point via a Web portal and secure connection on the World Wide Web.

BRIEF DESCRIPTION OF THE DRAWINGS

[0016] The present invention is disclosed with reference to the accompanying drawings, wherein:

[0017] FIG. 1 illustrates a call to an emergency number as processed according to the prior art;

[0018] FIG. 2 illustrates a call to an emergency number as processed by a first embodiment of the present invention;

[0019] FIG. 3 illustrates a call to an emergency number as processed by a second embodiment of the present invention;

[0020] FIG. 4 illustrates a call to an emergency number as processed by a third embodiment of the present invention; and

[0021] FIG. 5 is a schematic view of the data transponding device of the present invention.

[0022] Corresponding reference characters indicate corresponding parts throughout the several views. The examples set out herein illustrate several embodiments of the invention but should not be construed as limiting the scope of the invention in any manner.

DETAILED DESCRIPTION

[0023] Referring to FIG. 1, there is shown an illustration of a call to an emergency number as processed according to the prior art. When an emergency number is dialed from a telephone **100** both voice and ANI information are transmitted to a switch **102** in communication with the telephone **100**. The switch **102** routes the voice and ANI information to an appropriate emergency number answering point **110** based on the received ANI information.

[0024] Within the emergency number answering point **110** emergency number answering and routing equipment **113** divides the voice and ANI information. The emergency number answering and routing equipment **113** transmits the voice information to an emergency number controller **111** where it is stored in queue for the next available call-taker. Once a call-taker is available the emergency number controller **111** transmits the voice data to the call-taker work station **112**.

[0025] The emergency number answering and routing equipment **113** transmits the ANI information to an emergency number data routing equipment **114**. The emergency number data routing equipment **114** transmits the ANI information to the ALI database **120**. The ALI database references the ANI information for the telephone **100** with the physical address location stored within the database for the received ANI information. The physical address location of the telephone **100** is transmitted from the ALI database **120** to the emergency number answering point **110**. The emergency

number data routing equipment **114** transmits this information to the emergency number controller **111**. Once a call-taker is available the emergency number controller **111** transmits the line demarcation address location along with the voice data to the call-taker work station **112**. If the voice data is previously transmitted the line demarcation address location is immediately transmitted to the appropriate call-taker workstation **112**. The call-taker may then gather additional information from the caller and dispatch the appropriate services if necessary.

[0026] Referring to FIG. 2, there is shown an illustration of a call to an emergency number as processed according to a first embodiment of the present invention. As described in the prior art when an emergency number is dialed from a telephone **100** both voice and ANI information are transmitted to a switch **102** that routes the voice and ANI information to an appropriate emergency number answering point **110**. Within the emergency number answering point **110** emergency number answering and routing equipment **113** divides the voice and ANI information. The emergency number answering and routing equipment **113** transmits the voice information to an emergency number controller **111** where it is stored in queue for the next available call-taker. Once a call-taker is available the emergency number controller **111** transmits the voice data to the call-taker work station **112**. The emergency number answering and routing equipment **113** transmits the ANI information to an emergency number data routing equipment **114**.

[0027] The emergency number data routing equipment **114** transmits the ANI information to a data transponding device **130**. The data transponding device **130** transmits the ANI data to the ALI database **120**. The ALI database **120** references the ANI information for the telephone **100** with the line demarcation address location stored within the database for the received ANI information. The line demarcation address location of the telephone **100** is transmitted from the ALI database **120** to the data transponding device **130**.

[0028] The data transponding device **130** also transmits the ANI data to the detailed information storage device **140**. The detailed information storage device **140** references the ANI information for the telephone **100** with the detailed information stored within the database for the received ANI information. The detailed information is transmitted from the detailed information storage device **140** to the data transponding device **130**.

[0029] The detailed information can include but is not limited to actual phone location within a PBX (such as exact location, building, floor, and room number); structure information (such as class room, office building, warehouse, power plant, and floor plan layout); personal information (such as medical history, allergic reactions, current medications, and emergency contact information); or any special access requirements (such as keys, access codes, and building entry locations).

[0030] Referring to FIG. 5, the information transponding device **130** receives ANI data through the emergency number answering port **201**. A microprocessor **200** then relays the ANI data to the ALI database through the ALI database port **202**, and to the detailed information storage device through the Ethernet port **205**, to request information. A reference for the requests is stored in system memory **204**. The system memory **204** may be flash memory, random access memory, or a combination thereof. If available at the detailed information storage device the detailed information is transmitted

from the detailed information storage device back to the information transponding device through the Ethernet port **205** and stored in system memory **204**. The ALI information is transmitted from the ALI database through the ALI database port **202** and a software program residing in the micro-processor merges the detailed information with the ALI information. This modified data is then transmitted to the emergency number answering point through the emergency number answering port **201**. It is understood that the emergency number answering port **201**, the ALI database port **202**, and the Ethernet port **205** are capable of functioning as both an input and output port simultaneously.

[0031] It is understood that in the event of a delay in receiving either the ALI information or detailed information the information transponding device will transmit the non-delayed information to the emergency number answering point. In one embodiment the delayed information is stored in the system memory **204** for at least 5 minutes. The emergency number answering point may re-request information, and if available, the information transponding device resends the stored information.

[0032] The information transponding device **130** may also contain additional ports and voltage protected control lines. The ports may include digital inputs that connect directly to a plurality of control lines including, but not limited to, Carried Detect, Clear to Send, Request to Send, Data Set Ready, and Data Terminal Ready control lines to provide information status directly to the information transponding device. The ports may further include digital output lines converted to a proper voltage level that are used to originate the status of the control lines when needed. The digital inputs and outputs are connected to the information transponding device, through a self-healing connection. In the event that a cable becomes separated from the information transponding device the self-healing connection connects all necessary control lines and data signals such that the ANI and ALI signals will continue to work without interruption. Additional ports include analog converters to measure backup voltage, current, temperature and system status.

[0033] The information transponding device **130** may further comprise a watchdog timer to limit the amount of time the system is in an unknown state. If the system has a code failure such as a loop, stack over, or underrun the watchdog timer will reset the system with a cold boot. This allows for the system to run as intended without the need for a service tech to arrive on scene or access the device remotely. In one embodiment the watchdog timer resets the system if the system is in an unknown state for over 200 ms. In another embodiment the watchdog timer resets the system if the system is in an unknown state for over 62.5 ms.

[0034] The Ethernet port **205**, in addition to providing a connection to the detailed information storage device may further provide a connection to LAN switches, the Internet, the main database interface ("MDI"), the secondary database interface ("SDI"), and other information transponding devices. The Ethernet port **205** provides a fast connection to the detailed information stored at the detailed information storage device. In one embodiment the information transponding device receives the detailed information, if available, prior to receiving the ALI information.

[0035] Referring again to FIG. 2, the information transponding device **130** transmits the modified data to the emergency number answering point **110**. The emergency number data routing equipment **114** transmits this information to the emer-

gency number controller **111**. Once a call-taker is available the emergency number controller **111** transmits the physical address location along with the voice data to the call-taker workstation **112**. If the voice data is previously transmitted the physical address location is immediately transmitted to the appropriate call-taker workstation **112**. The call-taker may then gather additional information from the caller and dispatch the appropriate services if necessary. It is understood that the emergency number answering and routing equipment **113** and emergency number data routing equipment **114** may be multiple device or a single device capable of carrying out the required functions.

[0036] A tandem data transponding device **131** is communication with the emergency number answering point **110**, the ALI database **120** and detailed information storage device **140**. The tandem data transponding device **131** operates in the same manner as the data transponding device **130**. The tandem data transponding device **131** is connected to other devices via lines that are distinct from those connect the information transponding device **103**. This ensures that the information will be transmitted even if one of the devices is inoperable or a transmission line is down.

[0037] The detailed information is modified and updated by an authorized user **152**. The authorized user **152** connects to a Web portal **150** through the World Wide Web **151**. The Web portal **150** connects to both the MDI **142** and the SDI **143** through a secure connection **141**. The authorized user **152** inputs the detailed information and the MDI **142** and SDI **143** store the detailed information. The detailed information is then updated from the MDI **142** or SDI **143** to the detailed information storage device **140**. The MDI **142** and SDI **143** are national databases which store information for every system user. In one embodiment the detailed information storage device **140** is a local device and stores only information for users in a regionalized area. The information transponding device **130** requests detailed information from the MDI **142** and the SDI **143** in the event that no results are returned from the detailed information storage device **140**. It is understood that any number of database interfaces and storage device may be used.

[0038] The Web portal **150** provides a secure connection and personal access to the detailed information stored at the MDI **142** and the SDI **143**. Web Access is provided by cluster Web servers located in a plurality of sites that all use the same domain name. Domain Name Servers (DNS) provide the routing to the Web servers. When an authorized users modifies the information both the MDI **142** and the SDI **143** servers are written to simultaneously through an IP connection. By simultaneously writing to a plurality of servers a secondary copy of the information is available in the event of a failure. The information is transmitted through the Web portal and is protected by Web secure certificates. The Web certificates provide a high level of encryption directly between the host Web site servers and the authorized user's web browser.

[0039] An authorized user may sign into the system on the Web portal by using a unique user name and password. A first time user will receive a message and will have to respond to the message to provide verification which will allow further access to the Web sites. Business and residential users will also have all numbers that they are entering (to add additional information) tested to verify that they indeed have authorization to modify the information relating to these numbers. With residential, cellular, personal communications services

(hereinafter "PCS"), or voice over IP telephones the system will call out to these numbers and request a customer response to provide validity before the numbers may be placed in service.

[0040] When an authorized user enter the detailed information they additionally have the option of selecting notification options for when an emergency number is dialed from a particular telephone line. The authorized user can select a plurality of contacts to receive a notification message that an emergency number was dialed from that particular phone. The notification message may be, but is not limited to, an automatically generated pre-recorded phone call, a computer generated phone call, an E-mail, a text message, or a fax. The authorized user can modify what information is transmitted to each individual contact. The information can include all or part of the information that is sent to the emergency number answering point. The authorized user may further group telephone lines together such that when an emergency number is dialed from any one of those lines a particular contact will receive a notification message.

[0041] Referring to FIG. 3 there is shown an illustration of a call to an emergency number as processed according to a second embodiment of the present invention. As described in the first embodiment when an emergency number is dialed from a telephone 100 both voice and ANI information are transmitted to a switch 102 that routes the voice and ANI information to an appropriate emergency number answering point 110. Within the emergency number answering point 110 emergency number answering and routing equipment 113 divides the voice and ANI information. The emergency number answering and routing equipment 113 transmits the voice information to an emergency number controller 111 where it is stored in queue for the next available call-taker. Once a call-taker is available the emergency number controller 111 transmits the voice data to the call-taker work station 112. The emergency number answering and routing equipment 113 transmits the ANI information to an emergency number data routing equipment 114.

[0042] The emergency number data routing equipment 114 transmits the ANI information to a data transponding device 130. The data transponding device 130 transmits the ANI data to the detailed information storage device 140. The detailed information storage device 140 references the ANI information for the telephone 100 with the detailed information stored within the database for the received ANI information. The detailed information is transmitted from the detailed information storage device 140 to the data transponding device 130. The physical location information is provided directly from the detailed information storage device 140 without the need for accessing the ALI database (FIG. 2).

[0043] The detailed information can include but is not limited to actual phone location within a PBX (such as exact location, building, floor, and room number); structure information (such as class room, office building, warehouse, power plant, and floor plan layout); personal information (such as medical history, allergic reactions, current medications, and emergency contact information); or any special access requirements (such as keys, access codes, and building entry locations).

[0044] Referring to FIG. 5, the information transponding device 130 receives ANI data through the emergency number answering port 201. A microprocessor 200 then relays the ANI data to the to the detailed information storage device through the Ethernet port 205 to request information. A ref-

erence for the requests is stored in system memory 204. The system memory 204 may be flash memory, random access memory, or a combination thereof. If available at the detailed information storage device the detailed information is transmitted from the detailed information storage device back to the information transponding device through the Ethernet port 205 and then transmitted to the emergency number answering point.

[0045] The information transponding device 130 may also contain additional ports and voltage protected control lines. The ports may include digital inputs that connect directly to a plurality of control lines including, but not limited to, Carried Detect, Clear to Send, Request to Send, Data Set Ready, and Data Terminal Ready control lines to provide information status directly to the information transponding device. The ports may further include digital output lines converted to a proper voltage level that are used to originate the status of the control lines when needed. The digital inputs and outputs are connected to the information transponding device through a self-healing connection. In the event that a cable becomes separated from the information transposing device the self-healing connection connects all necessary control lines and data signals such that the ANI and ALI signals will continue to work without interruption. Additional ports include analog converters to measure backup voltage, current, temperature, and system status.

[0046] The information transponding device 130 may further comprise a watchdog timer to limit the amount of time the system is in an unknown state. If the system has a code failure such as a loop, stack over or underrun the watchdog timer will reset the system with a cold boot. This allows for the system to run as intended without the need for a service tech to arrive on scene or access the device remotely. In one embodiment the watchdog timer resets the system if the system is in an unknown state for over 200 ms. In another embodiment the watchdog timer resets the system if the system is in an unknown state for over 62.5 ms.

[0047] The Ethernet port 205, in addition to providing a connection to the detailed information storage device may further provide a connection to LAN switches, the Internet, the main database interface ("MDI"), the secondary database interface ("SDI"), and other information transponding devices. The Ethernet port 205 provides a fast connection to the detailed information stored at the detailed information storage device.

[0048] Referring again to FIG. 3, the information transponding device 130 transmits the modified data to the emergency number answering point 110. The emergency number data routing equipment 114 transmits this information to the emergency number controller 111. Once a call-taker is available the emergency number controller 111 transmits the line demarcation location along with the voice data to the call-taker work station 112. If the voice data is previously transmitted the line demarcation location is immediately transmitted to the appropriate call-taker workstation 112. The call-taker may then gather additional information from the caller and dispatch the appropriate services if necessary. It is understood that the emergency number answering and routing equipment 113 and emergency number data routing equipment 114 may be multiple devices or a single device capable of carrying out the required functions.

[0049] A tandem data transponding device 131 is communication with the emergency number answering point 110, the ALI database 120 and detailed information storage device

140. The tandem data transponding device **131** operates in the same manner as the data transponding device **130**. The tandem data transponding device **131** is connected to other devices via lines that are distinct from those connect the information transponding device **103**. This ensures that the information will be transmitted even if one of the devices is inoperable or a transmission line is down.

[0050] The detailed information is modified and updated by an authorized user **152**. The authorized user **152** connects to a Web portal **150** through the World Wide Web **151** as set forth in the first embodiment.

[0051] Referring to FIG. 4, there is shown an illustration of a call to an emergency number as processed according to a third embodiment of the present invention. As described in the first embodiment when an emergency number is dialed from a telephone **100** both voice and ANI information are transmitted to a switch **102** that routes the voice and ANI information to an appropriate emergency number answering point **110**. Within the emergency number answering point **110** emergency number answering and routing equipment **113** divides the voice and ANI information. The emergency number answering and routing equipment **113** transmits the voice information to an emergency number controller **111** where it is stored in queue for the next available call-taker. Once a call-taker is available the emergency number controller **111** transmits the voice data to the call-taker work station **112**. The emergency number answering and routing equipment **113** transmits the ANI information to an emergency number data routing equipment **114**.

[0052] The emergency number data routing equipment **114** transmits the ANI information to an ALI database **120**. The ALI database **120** is connected to the detailed information storage device **140**. The ALI database **120** accesses both the line demarcation address location and the detailed information stored in the detailed information storage device **140**. The detailed information is merged with the ALI information and transmitted to the emergency number data routing equipment **114**. It is understood that both the ALI information and detailed information may be stored in the same device and may be merged prior to receiving any ANI information from an emergency number answering point **110**.

[0053] The detailed information is modified and updated by an authorized user **152**. The authorized user **152** connects to a Web portal **150** through the World Wide Web **151** as set forth in the first embodiment.

[0054] While the invention has been described with reference to particular embodiments, it will be understood by those skilled in the art that various changes may be made and equivalents may be substituted for elements thereof without departing from the scope of the invention. In addition, many modifications may be made to adapt a particular situation or material to the teachings of the invention without departing from the scope of the invention.

[0055] Therefore, it is intended that the invention not be limited to the particular embodiments disclosed as the best mode contemplated for carrying out this invention, but that the invention will include all embodiments falling within the scope and spirit of the appended claims.

1. An emergency number data transponding device comprising:
 - at least one input port capable of receiving ANI information from an emergency number answering point, ALI

information from an ALI database and detailed information from a storage device distinct from said ALI database;

- a microprocessor to generate modified information by assimilating said ALI information and said detailed information and converting said modified information into a form readable by said emergency number answering point;
- at least one output port capable of transmitting said modified information to said emergency number answering point.

2. The emergency number data transponding device of claim 1 wherein said detailed information is updated and modified by an authorized user via a secure Internet connection and a secure Web portal on the World Wide Web.

3. The emergency number data transponding device of claim 1 further comprising an automatic notification device capable of generating and transmitting automatic notifications to a predetermined list of contacts upon receipt of ANI information from said emergency number answering point.

4. The emergency number data transponding device of claim 3 wherein said predetermined list of contacts is updated and modified by an authorized user via a secure Web portal on the World Wide Web.

5. The emergency number data transponding device of claim 1 wherein said automatic notifications are selected from the group consisting essentially of: a prerecorded phone message to a phone line, an electronic mailing to an e-mail address, a page to a pager, a text message to a mobile phone, an instant message to an instant messaging device, a fax to a facsimile device, and any combination thereof.

6. The emergency number data transponding device of claim 1 wherein said detailed information includes emergency contact information.

7. The emergency number data transponding device of claim 1 wherein said detailed information includes allergies and current medications.

8. The emergency number data transponding device of claim 1 wherein said detailed information includes the specific location of a telephone within a private branch exchange.

9. A notification system for communicating user generated information to an emergency number response center comprising:

- at least one remote storage database capable of storing detailed information about a particular phone line;
- a secure Internet connection to said storage device;
- a secure Web portal in communication with the World Wide Web and said secure Internet connection to allow an authorized user to modify and update said detailed information; and

an emergency data transponding device, wherein said emergency data transponding device is capable of automatically receiving ANI information from an emergency number answering point and ALI information from an ALI database; retrieving detailed information from said at least one remote storage database associated with said ANI information; modifying said ALI information to include said detailed information to form assimilated information; and transmitting said assimilated information to an emergency number answering point in a format employed at said emergency number answering point.

10. The notification system of claim 9 further comprising a tandem emergency data transponding device independently

in communication with said remote storage database and said emergency number answering point.

11. The notification system of claim **9** further comprising an automatic notification device capable of generating and transmitting automatic notifications to a predetermined list of contacts upon receipt of ANI information from said emergency number answering point.

12. The notification system of claim **9** wherein said emergency data transponding device is connected to said emergency number answering point and said ALI database via a phone line.

13. The notification system of claim **9** wherein said emergency data transponding device is connected to said at least one remote storage database via an internet connection.

14. A detailed information database comprising:
an input port capable of receiving ANI information from an emergency number answering point;
a storage device capable of storing detailed information about a particular phone line;
a secure Internet connection to said storage device;
a secure Web portal in communication with the World Wide Web and said secure Internet connection to allow an authorized user to modify and update said detailed information; and
a microprocessor to generate readable information in a format employed at said emergency number answering point; and
at least one output port capable of transmitting said readable Information to said emergency number answering point.

15. The detailed information database of claim **14** further comprising an automatic notification device capable of generating and transmitting automatic notifications to a predetermined list of contacts upon receipt of ANI information from said emergency number answering point.

16. The detailed information database of claim **15** further comprising a tandem detailed information database independently in communication with said emergency number answering point comprising:

- a input port capable of receiving ANI information from said emergency number answering point;
- a tandem storage device capable of storing detailed information about a particular phone line;
- a secure Internet connection to said tandem storage device;
- a secure Web portal in communication with the World Wide Web and said secure Internet connection to allow an authorized user to modify and update said detailed information; and
- a tandem microprocessor to generate readable information in a format employed at said emergency number answering point;
- at least one output port capable of transmitting said readable information to said emergency number answering point; and
- a tandem automatic notification device capable of generating and transmitting automatic notifications to a predetermined list of contacts upon receipt of ANI data from said emergency number answering point.

17. The detailed information database of claim **14** further comprising:

- a connection to an ALI database;
- an ALI controller capable of transmitting ANI information to said ALI database and receiving ALI information from said ALI database; and
- a microprocessor to modify said ALI information to include said detailed information and generate readable data in a format employed at said emergency number answering point that includes said ALI information and said detailed information.

18. The detailed information database of claim **14** wherein said ANI information is generated from a land line, mobile line, or voice over IP line.

* * * * *