

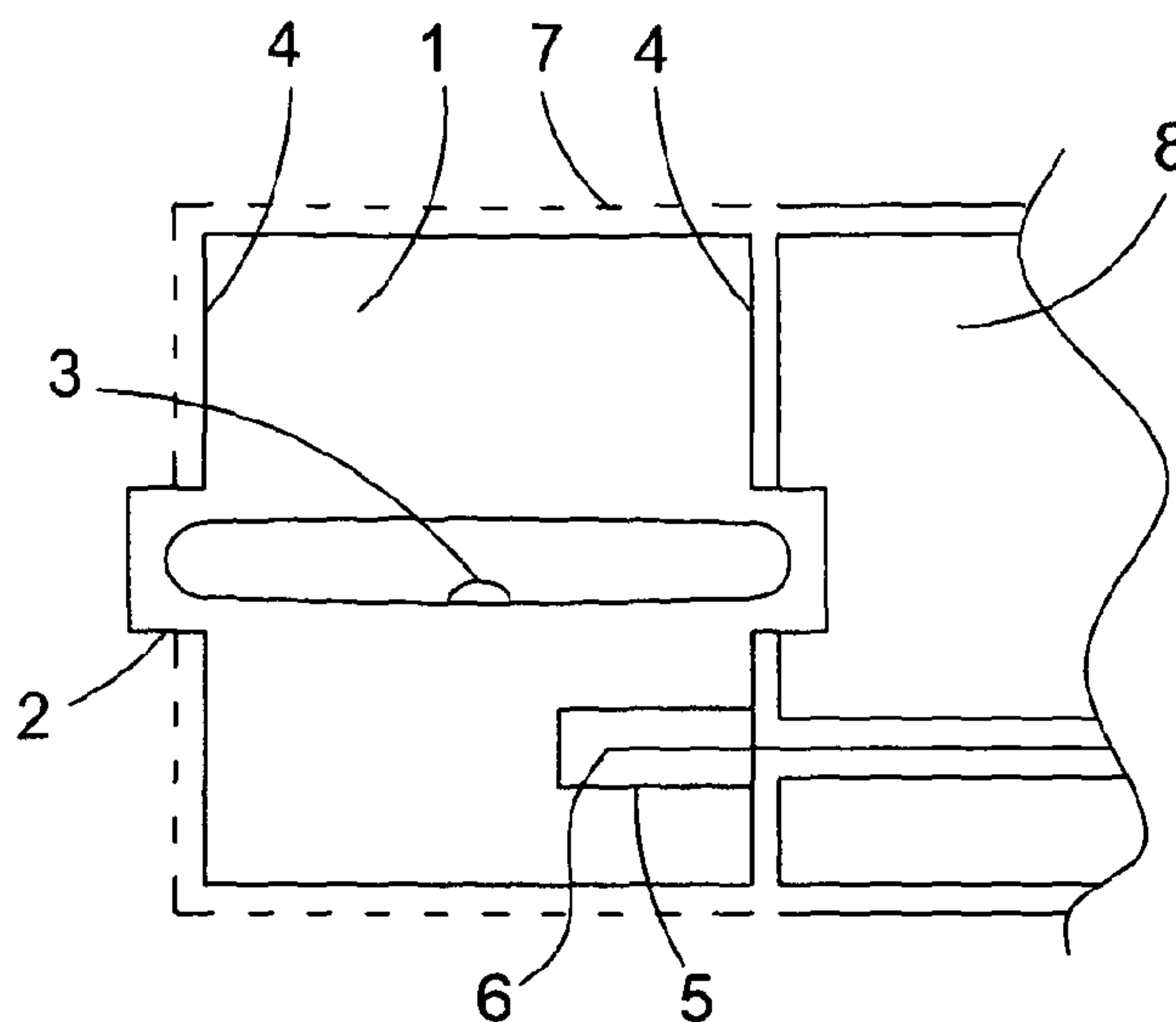

(86) Date de dépôt PCT/PCT Filing Date: 2011/07/05
 (87) Date publication PCT/PCT Publication Date: 2012/01/12
 (45) Date de délivrance/Issue Date: 2017/09/19
 (85) Entrée phase nationale/National Entry: 2012/12/20
 (86) N° demande PCT/PCT Application No.: GB 2011/001015
 (87) N° publication PCT/PCT Publication No.: 2012/004557
 (30) Priorité/Priority: 2010/07/05 (GB1011303.3)

(51) Cl.Int./Int.Cl. *H01J 65/04* (2006.01)
 (72) Inventeurs/Inventors:
 NEATE, ANDREW SIMON, GB;
 PRESTON, BARRY, GB
 (73) Propriétaire/Owner:
 CERAVISION LIMITED, GB
 (74) Agent: BRION RAFFOUL

(54) Titre : SOURCE LUMINEUSE A PLASMA COMMANDEE PAR MICROONDES
 (54) Title: MICROWAVE DRIVEN PLASMA LIGHT SOURCE



(57) Abrégé/Abstract:

A lucent crucible of a Lucent Waveguide Microwave Plasma Light Source (LWMPLS) comprising a Light Emitting Resonator (LER) in form of a crucible (1) of fused quartz which has a central void (2) having microwave excitable material (3) within it. In one example, the void is 4 mm in diameter and has a length (L) of 21 mm. The LWMPLS is operated at a power (P) of 280 W and thus with a plasma loading P/L of 133 w/cm and a wall loading of 106 w/cm². The lamp is thus operated with a high efficiency - in terms of lumens per watt - while having a reasonable lifetime.

(12) INTERNATIONAL APPLICATION PUBLISHED UNDER THE PATENT COOPERATION TREATY (PCT)

(19) World Intellectual Property Organization
International Bureau(43) International Publication Date
12 January 2012 (12.01.2012)(10) International Publication Number
WO 2012/004557 A1(51) International Patent Classification:
H01J 65/04 (2006.01)(21) International Application Number:
PCT/GB2011/001015(22) International Filing Date:
5 July 2011 (05.07.2011)

(25) Filing Language: English

(26) Publication Language: English

(30) Priority Data:
1011303.3 5 July 2010 (05.07.2010) GB(71) Applicant (for all designated States except US): **CER-
AVISION LIMITED** [GB/GB]; The Mansion, Bletchley
Park, Wilton Avenue, Bletchley MK3 6EB (GB).

(72) Inventors; and

(75) Inventors/Applicants (for US only): **NEATE, Andrew
Simon** [GB/GB]; 5 Phillips Road, Fairford Leys, Ayles-
bury, Buckinghamshire HP19 7FN (GB). **PRESTON,
Barry** [GB/GB]; 6 Folville Street, Ashby Folville, Melton
Mowbray, Leicestershire LE14 2TE (GB).(74) Agent: **NIGEL BROOKS CPA**; Hill Hampton, East
Meon, Petersfield, Hampshire GU32 1QN (GB).(81) Designated States (unless otherwise indicated, for every
kind of national protection available): AE, AG, AL, AM,
AO, AT, AU, AZ, BA, BB, BG, BH, BR, BW, BY, BZ,
CA, CH, CL, CN, CO, CR, CU, CZ, DE, DK, DM, DO,
DZ, EC, EE, EG, ES, FI, GB, GD, GE, GH, GM, GT,
HN, HR, HU, ID, IL, IN, IS, JP, KE, KG, KM, KN, KP,
KR, KZ, LA, LC, LK, LR, LS, LT, LU, LY, MA, MD,
ME, MG, MK, MN, MW, MX, MY, MZ, NA, NG, NI,
NO, NZ, OM, PE, PG, PH, PL, PT, RO, RS, RU, SC, SD,
SE, SG, SK, SL, SM, ST, SV, SY, TH, TJ, TM, TN, TR,
TT, TZ, UA, UG, US, UZ, VC, VN, ZA, ZM, ZW.(84) Designated States (unless otherwise indicated, for every
kind of regional protection available): ARIPO (BW, GH,
GM, KE, LR, LS, MW, MZ, NA, SD, SL, SZ, TZ, UG,
ZM, ZW), Eurasian (AM, AZ, BY, KG, KZ, MD, RU, TJ,
TM), European (AL, AT, BE, BG, CH, CY, CZ, DE, DK,
EE, ES, FI, FR, GB, GR, HR, HU, IE, IS, IT, LT, LU,
LV, MC, MK, MT, NL, NO, PL, PT, RO, RS, SE, SI, SK,
SM, TR), OAPI (BF, BJ, CF, CG, CI, CM, GA, GN, GQ,
GW, ML, MR, NE, SN, TD, TG).

Published:

— with international search report (Art. 21(3))

(54) Title: MICROWAVE DRIVEN PLASMA LIGHT SOURCE

Figure 1

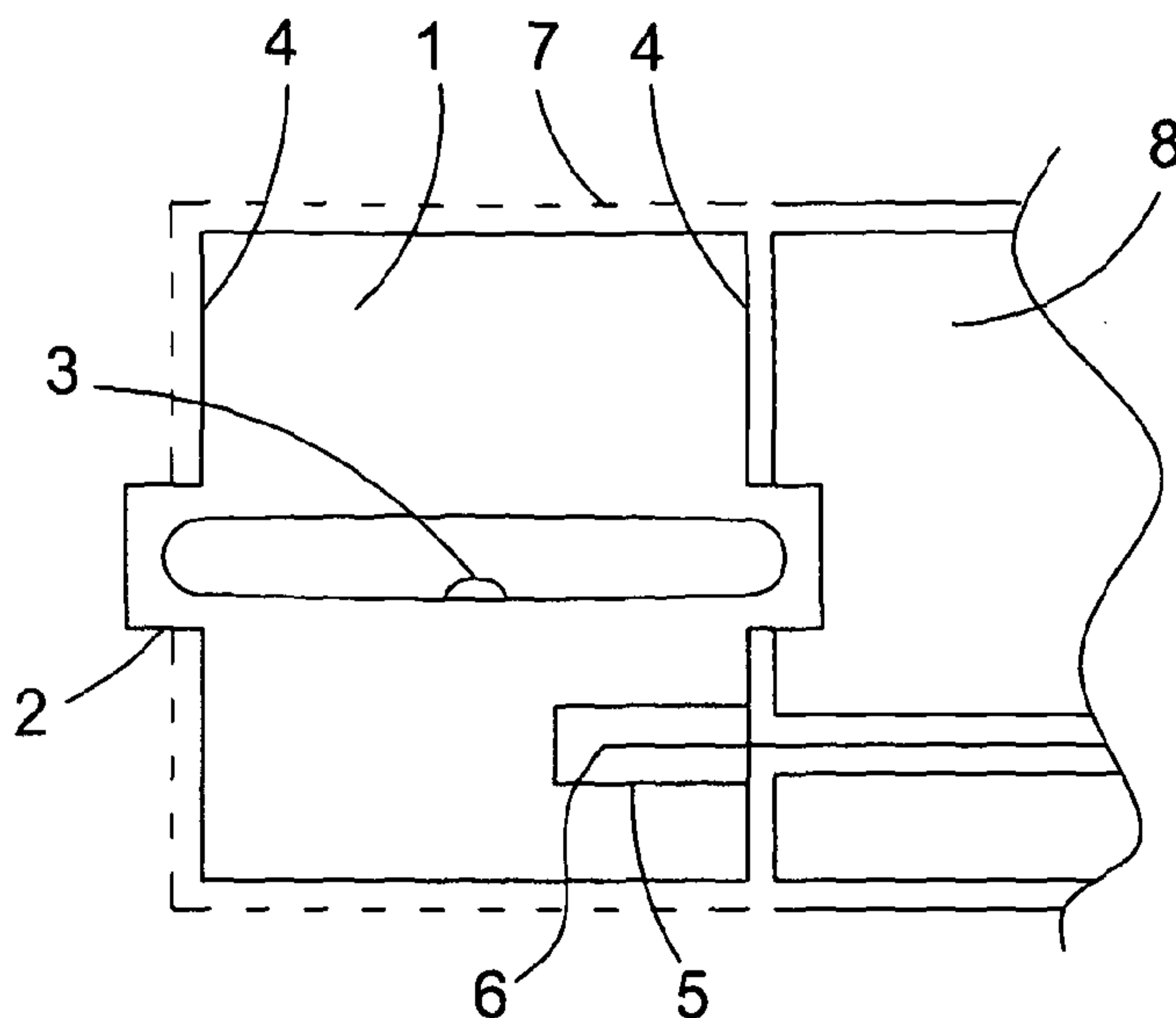
(57) Abstract: A lucent crucible of a Lucent Waveguide Microwave Plasma Light Source (LWMPLS) comprising a Light Emitting Resonator (LER) in form of a crucible (1) of fused quartz which has a central void (2) having microwave excitable material (3) within it. In one example, the void is 4 mm in diameter and has a length (L) of 21 mm. The LWMPLS is operated at a power (P) of 280 W and thus with a plasma loading P/L of 133 w/cm and a wall loading of 106 w/cm². The lamp is thus operated with a high efficiency - in terms of lumens per watt - while having a reasonable lifetime.

MICROWAVE DRIVEN PLASMA LIGHT SOURCE

The present invention relates to a plasma light source.

5 In European Patent No EP1307899, granted in our name there is claimed a light source comprising a waveguide configured to be connected to an energy source and for receiving electromagnetic energy, and a bulb coupled to the waveguide and containing a gas-fill that emits light when receiving the electromagnetic energy from the waveguide, characterised in that:

- 10 (a) the waveguide comprises a body consisting essentially of a dielectric material having a dielectric constant greater than 2, a loss tangent less than 0.01, and a DC breakdown threshold greater than 200 kilovolts/inch, 1inch being 2.54cm,
- (b) the wave guide is of a size and shape capable of supporting at least one electric field maximum within the wave guide body at at least one operating frequency
- 15 within the range of 0.5 to 30GHz,
- (c) a cavity depends from a first side of the waveguide,
- (d) the bulb is positioned in the cavity at a location where there is an electric field maximum during operation, the gas-fill forming a light emitting plasma when receiving microwave energy from the resonating waveguide body, and
- 20 (e) a microwave feed positioned within the waveguide body is adapted to receive microwave energy from the energy source and is in intimate contact with the waveguide body.

In our European Patent No 2,188,829 there is described and claimed a light

25 source to be powered by microwave energy, the source having:

- a body having a sealed void therein,
- a microwave-enclosing Faraday cage surrounding the body,
 - the body within the Faraday cage being a resonant waveguide,
- a fill in the void of material excitable by microwave energy to form a light

30 emitting plasma therein, and

- an antenna arranged within the body for transmitting plasma-inducing, microwave energy to the fill, the antenna having:

- a connection extending outside the body for coupling to a source of microwave energy;

wherein:

- the body is a solid plasma crucible of material which is lucent for exit of light therefrom, and
- the Faraday cage is at least partially light transmitting for light exit from the plasma crucible,

the arrangement being such that light from a plasma in the void can pass through the plasma crucible and radiate from it via the cage.

10

We refer to this as our Light Emitting Resonator or LER patent. Its main claim as immediately above is based, as regards its prior art portion, on the disclosure of our EP1307899, first above.

15

In our European Patent Application No 08875663.0, published under No WO2010055275, there is described and claimed a light source comprising:

- a lucent waveguide of solid dielectric material having:
 - an at least partially light transmitting Faraday cage surrounding the waveguide, the Faraday cage being adapted for light transmission radially,
 - a bulb cavity within the waveguide and the Faraday cage and
 - an antenna re-entrant within the waveguide and the Faraday cage and
- a bulb having a microwave excitable fill, the bulb being received in the bulb cavity.

20

25

We refer to this as our Clam Shell application, in that the lucent wave guide forms a clam shell around the bulb.

As used in our LER patent, our Clam Shell application and this specification:

- "microwave" is not intended to refer to a precise frequency range. We use "microwave" to mean the three order of magnitude range from around 300MHz to around 300GHz;
- "lucent" means that the material, of which an item described as lucent is comprised, is transparent or translucent;

30

- “plasma crucible” means a closed body enclosing a plasma, the latter being in the void when the void’s fill is excited by microwave energy from the antenna;
- “Faraday cage” means an electrically conductive enclosure of electromagnetic radiation, which is at least substantially impermeable to electromagnetic waves at
5 the operating, i.e. microwave, frequencies.

We have recently disclosed LER improvements in Patent Applications filed on 30th June 2011, under Nigel Brooks references Nos 3133 and 3134. The improvements relate to the incorporation of a lucent tubes within a bore in the solid
10 body, the tube being integral with the body and having the void formed in it. In order to put beyond doubt that the present improvement applies to the improvements of these two applications, we define as follows:

The LER patent, the Clam Shell Applications and the above LER
15 improvement applications have in common that they are in respect of:

A microwave plasma light source having:

- a Faraday cage:
 - delimiting a waveguide and
 - being at least partially lucent, and normally at least partially transparent,
20 for light emission from it, and
 - normally having a non-lucent closure;
 - a body of solid-dielectric, lucent material embodying the waveguide within the Faraday cage;
 - a closed void in the waveguide containing microwave excitable material; and
25 • provision for introducing plasma exciting microwaves into the waveguide;
- the arrangement being such that on introduction of microwaves of a determined frequency a plasma is established in the void and light is emitted via the Faraday cage.

In this specification, we refer to such a light source as a Lucent Waveguide
30 Microwave Plasma Light Source or LWMPLS.

With the objective of improving our LWMPLS, we have determined that by comparison with conventional plasma lamps using electroded bulbs we can achieve higher wattage per unit length of plasma.

5 To set this in perspective, the light output and lives of conventional electroded plasma, i.e. HID (High Intensity Discharge), bulbs is very dependent on both the minimum and maximum wall temperature. The minimum wall temperature sets the vapour pressure of the additives, the higher the additive pressure generally the higher the light output. The maximum wall temperature sets a limit on the life of the bulb.
10 Below 725°C bulbs can have a long life; above 850°C the life deteriorates rapidly.

The wall loading of a bulb is its input power divided by internal bulb surface area, usually expressed in Watts per cm². Wall loading is used as crude metric to encompass both temperatures. Many proposals have been made to minimise the
15 difference between these two temperatures. For long life of electroded bulbs, greater than 15,000hrs life, 20 Watts per cm² is regarded as an upper limit while 50 Watts per cm² bulb lives are reckoned to be less than 2,000hrs.

The efficiency with which microwave energy is converted into light – in terms
20 of lumens per watt - increases in our LWMPLSs with their operating wattage, all other things being equal. This results from maximum temperature in the plasma increasing and is linked to conductivity or skin depth of the plasma which decreases as the power per unit length is increased.

25 We have been surprised by how marked this effect is and accordingly, we now believe that we can specify improved LWMPLS and LER performance, in terms of them or at least their plasma voids being short for their operational power.

According to the invention there is provided a Lucent Waveguide Microwave
30 Plasma Light Source having a void length L and a rated power P, wherein:

- the plasma loading of the rated power divided by the void length, i.e. P/L, is at least 100W per cm,

the void length being the overall void length minus two radii of a central portion of the void.

We prefer to operate at 125W per cm or higher and for higher powers at least
5 140W per cm.

Measuring plasma loading in terms of the actual length of the plasma in the void, which may be able to be observed through the lucent waveguide, is awkward. We prefer to measure the overall length of the void and subtract its radius from each
10 end on the basis that the plasma is strongest in the central parallel portion of a domed end void and does not extend to the extreme end of flatter ended voids. While, it is possible to measure the actual microwave power, or at least the power transferred to a magnetron powering a LWMPLS, we prefer to measure power in terms of the rated power of the light source, i.e. the overall power consumption of the light source.

15

In some of our LWMPLSs, the plasma void is directly in the lucent crucible, as in our LER, and in others the plasma void is in a lucent bulb within a lucent waveguide as in our Clamshell Application. This invention and the definition of our LWMPLSs is not restricted to these two arrangements. Other arrangements are the
20 subject of certain of our pending and un-published patent applications.

Again in certain of our LWMPLSs, we are able to operate at much lower internal surface areas of their voids for their operational power.

25 In particular, we prefer to operate at a wall loading of between 100 W per cm² and 300 W per cm². For higher powers, we would normally expect to operate at least at 125 W per cm² and preferably in the range between 150 W per cm² and 250 W per cm².

30 We measure wall loading in terms of the internal surface area of the part of the void for which we measure plasma loading, with the power being the rated power.

We ascribe the fact that we can operate at such higher wall loading than traditionally to the conductive and radiant heat transfer occurring from our lucent crucibles and waveguides.

5 To help understanding of the invention, a specific embodiment thereof will now be described by way of example and with reference to the accompanying drawings, in which:

Figure 1 is a side view of an LER in accordance with the invention and Figure 2 is a larger scale scrap view of the void.

10

Referring to the drawings, a lucent crucible 1 for an LER LWMPLS has a central void 2 having microwave excitable material 3 within it. The void is 4mm in diameter and 21mm long. The crucible is of fused quartz and is 21mm long between end flats 4 and is circular cylindrical with a 49mm outside diameter. The identicalness of the length of the void and the length between the end flats of the crucible results from this being constructed from a piece of quartz, having a bore and closed at the ends of the bore. The length of the crucible – but not the void – is somewhat arbitrary for present purposes, because in the preferred TM_{010} mode, resonance is independent of the crucible length. This LER is designed to operate at 20 280 watts at 2.45GHz.

25

Also shown are a bore 5 for an antenna 6 to introduce microwaves into the crucible and a Faraday cage 7 for retaining microwave resonance within the crucible. It is backed by an aluminium carrier 8 to which it is held by the cage.

30

With the LER operating at 280 Watts in TM_{010} mode, corresponding to a plasma loading of 133W per cm and a wall loading of 106W per cm^2 , we measure a wall temperature of 700°C. Such a device has an efficacy of up to 110 lumens per Watt.

To measure the plasma loading, we divide the rated power of the LER by the length of the plasma. In our experience the plasma 11 stops just short of the full length 12 of the void, as shown in Figure 2. The void generally has domed ends 14.

We measure the overall length of the void and subtract its radius 15 from each end on the basis that the plasma is strongest in the central parallel portion of a domed end void and does not extend to the extreme ends of flatter ended voids.

5 In order to achieve efficiencies > 110 lumens per Watt we have found it necessary to increase the loading per unit length of plasma to be greater than 150 W per cm. In order that the lamp has a reasonable lifetime, simultaneously, we have found it necessary to restrict the maximum wall loading to be less than 300 W per cm² and preferably less than 250 W per cm².

10

Examples of higher plasma loadings for crucibles operating in the TM₀₁₀ mode are:

- 1. Void Length 11mm
Void Diameter 5mm
15 Power 280W
Plasma Loading 255W per cm
Wall Loading 162W per cm²
- 2. Void Length 14mm
20 Void Diameter 3mm
Power 280W
Plasma Loading 200W per cm
Wall Loading 210W per cm²

25

Thus for high efficiency LERs with reasonably long life the operating conditions may be set out as follows:

Arc or plasma loading	Power input per unit length of plasma > 100 W per cm
Wall loading	100 W per cm ² < Plasma crucible wall loading < 300W per cm ²
Preferred wall loading	100 W per cm ² < Plasma crucible wall loading < 250W per cm ²

While these conditions apply to resonators operating in any mode, cylindrical LERs operating in the TM₀₁₀ and TM₁₁₀ modes have advantages in ease of manufacturability and cost compared to resonators operating in other modes. This is because these two modes have the property that the resonant frequency is independent of the length of the cavity. This makes it particularly easy to vary the power input per unit length of plasma by varying the length of the LER and using butt sealed tubes at each end of the resonator the cost is kept to a minimum.

What is claimed is:

1. A Lucent Waveguide Microwave Plasma Light Source comprising:
a magnetron of a power such that the light source has a rated power (P) and
a body of solid-dielectric lucent material having a closed void length (L),
wherein:
a plasma loading of the rated power divided by the void length (P/L) is at least 100 W per
cm,
a wall loading of rated power divided by internal surface area of the void is between 100 W
per cm²
and 300 W per cm²,
the void length being the overall void length minus a diameter of a central portion of the
void and
the internal surface area being measured between one half of the diameter of the central
portion from each end of the void.
2. A Lucent Waveguide Microwave Plasma Light Source as claimed in claim 1, wherein the
plasma loading of the rated power divided by the void length is at least 125 W per cm.
3. A Lucent Waveguide Microwave Plasma Light Source as claimed in claim 1, wherein the
plasma loading of the rated power divided by the void length is at least 140 W per cm.
4. A Lucent Waveguide Microwave Plasma Light Source as claimed in claim 1, wherein the
void is directly in a lucent waveguide body.
5. A Lucent Waveguide Microwave Plasma Light Source as claimed in claim 1, wherein the
void is in a lucent bulb within a lucent waveguide.
6. A Lucent Waveguide Microwave Plasma Light Source as claimed in claim 1, wherein the
wall loading of rated power divided by internal surface area of the void is between 125 W per
cm² and 300 W per cm².
7. A Lucent Waveguide Microwave Plasma Light Source as claimed in claim 6, wherein the
wall loading of rated power divided by internal surface area of the void is between 150 W per
cm² and 250 W per cm².

1/1

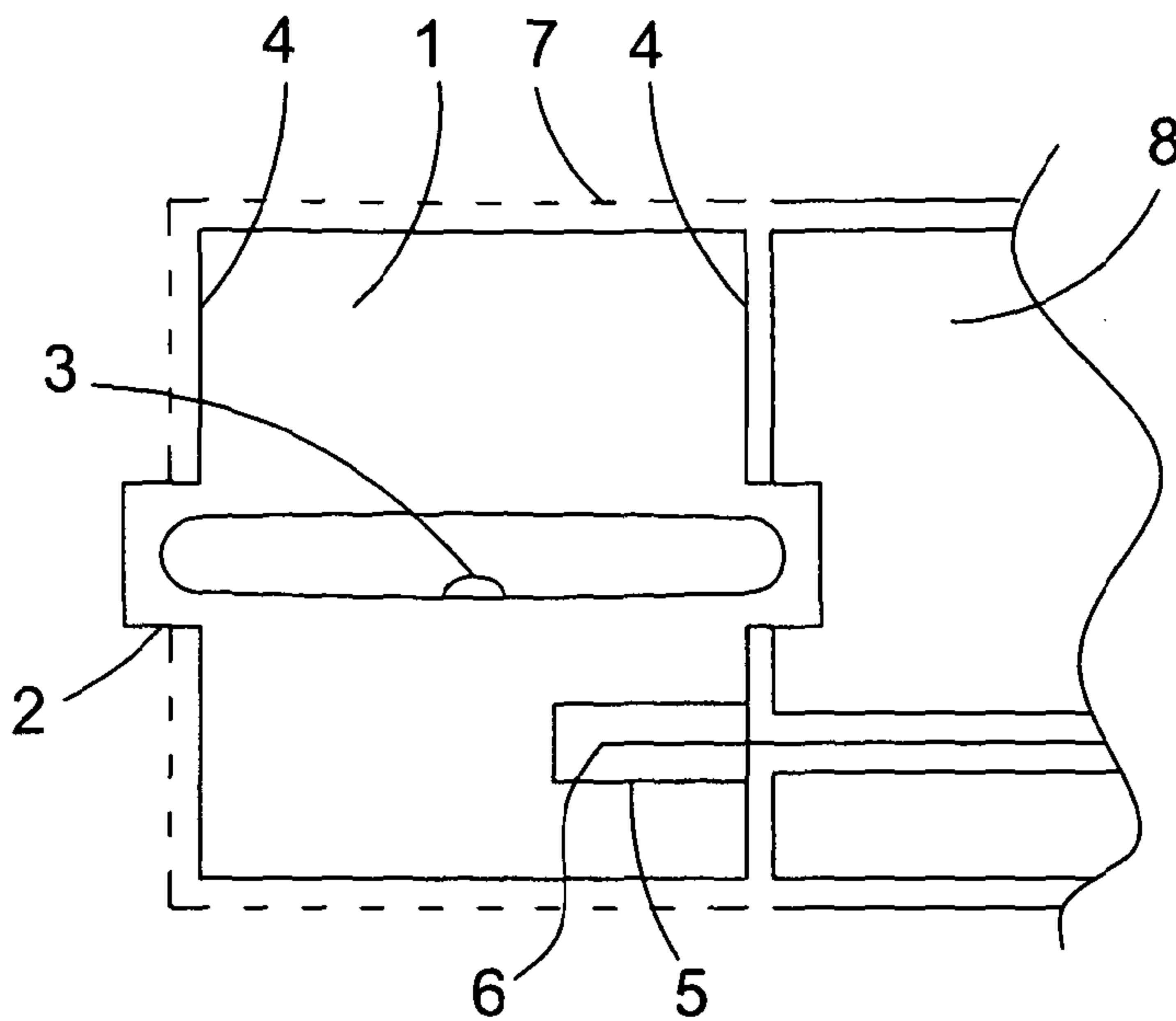

Figure 1

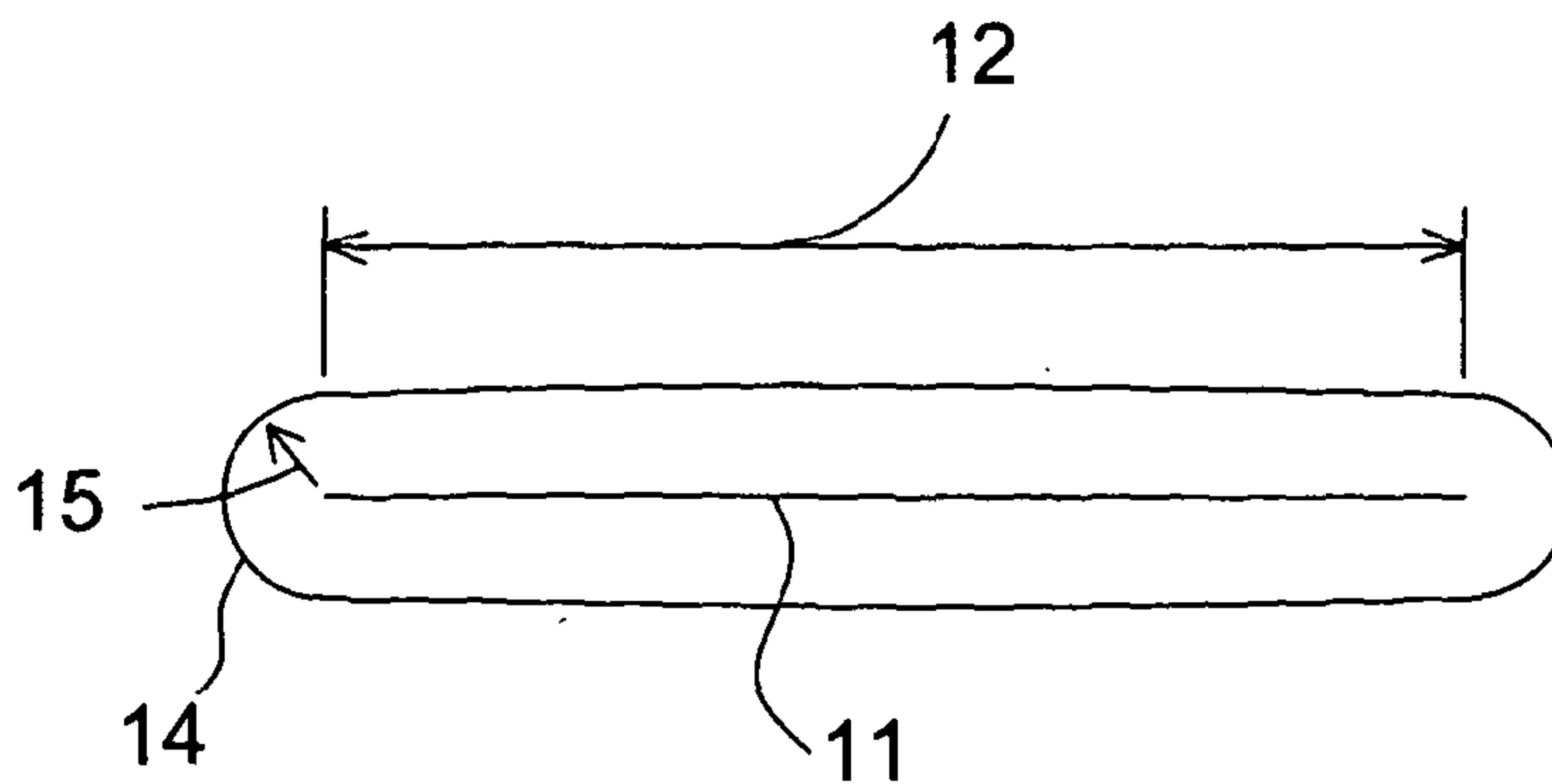

Figure 2

