

(No Model.)

3 Sheets—Sheet 2.

J. B. TARR.
TOBACCO SHAVER.

No. 480,638.

Patented Aug. 9, 1892.

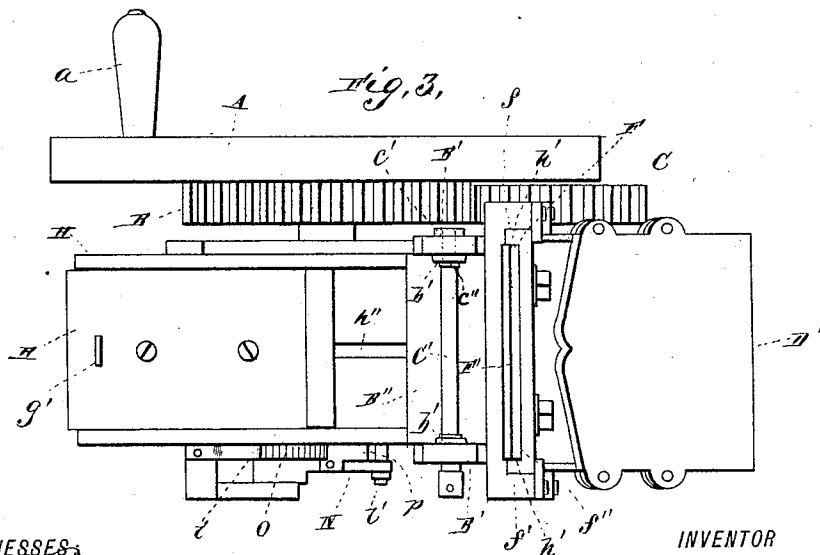
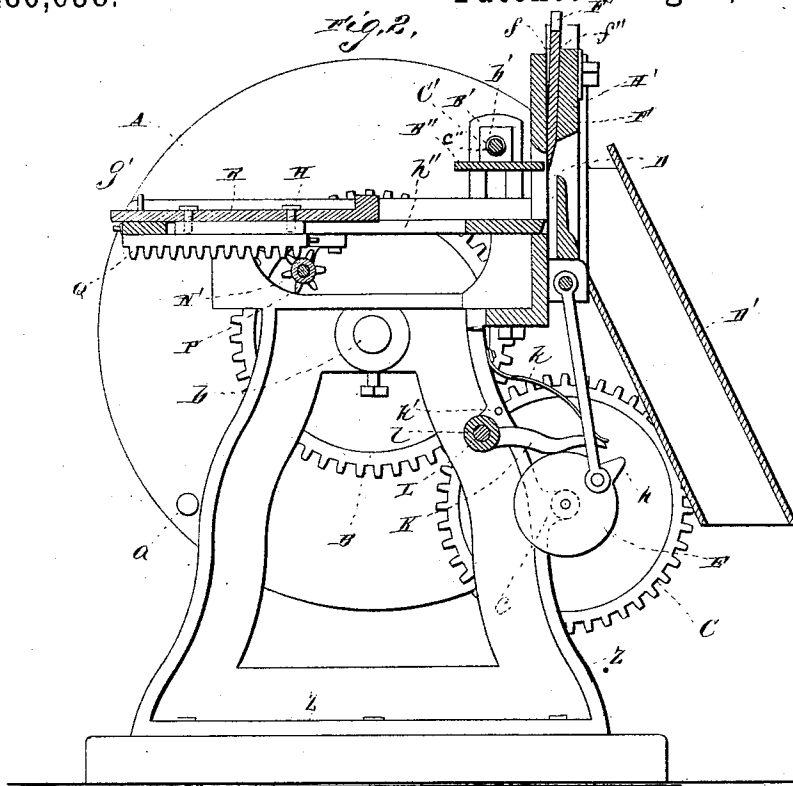

WITNESSES
Chas. L. Taylor
Philip Masini

INVENTOR
John Blake Tarr
 BY *E. W. Anderson*
his ATTORNEY.

(No Model.)

3 Sheets—Sheet 3.

J. B. TARR.
TOBACCO SHAVER.

No. 480,638.

Patented Aug. 9, 1892.

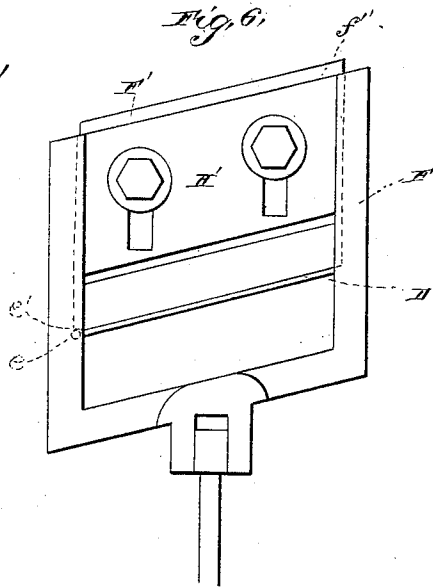
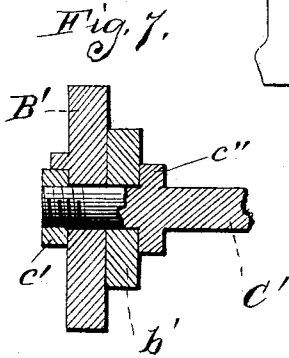
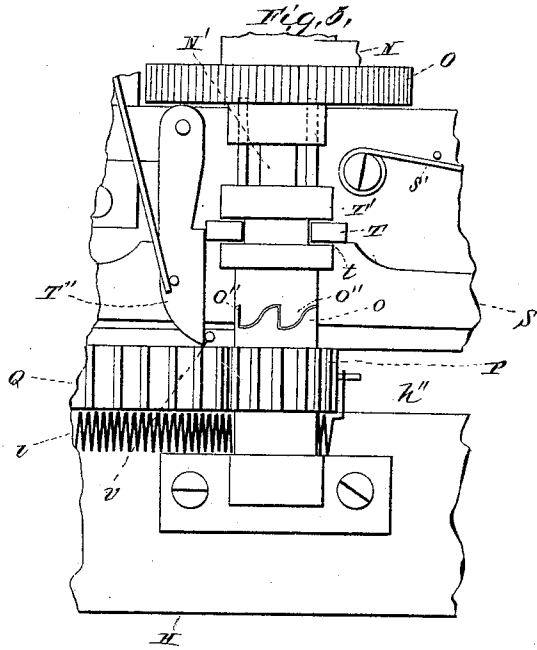

WITNESSES:
Chas. L. Taylor
Philip C. Masi.

INVENTOR
John Blake Tarr.
 BY *E. W. Anderson*
 his ATTORNEY.

UNITED STATES PATENT OFFICE.

JOHN BLAKE TARR, OF NEW BEDFORD, MASSACHUSETTS.

TOBACCO-SHAVER.

SPECIFICATION forming part of Letters Patent No. 480,638, dated August 9, 1892.

Application filed December 23, 1890. Serial No. 375,614. (No model.)

To all whom it may concern:

Be it known that I, JOHN BLAKE TARR, a citizen of the United States, and a resident of New Bedford, in the county of Bristol, and State of Massachusetts, have invented certain new and useful Improvements in Tobacco-Shavers; and I do declare the following to be a full, clear, and exact description of the invention, such as will enable others skilled in the art to which it appertains to make and use the same, reference being had to the accompanying drawings, and to letters of reference marked thereon, which form a part of this specification.

Figure 1 of the drawings is a representation of the invention and is a perspective view. Fig. 2 is a vertical longitudinal section. Fig. 3 is a top view. Fig. 4 is a reverse view of the under side of the feed-slide. Fig. 5 is a reverse view of same in detail modified form. Fig. 6 is a detail view, and Fig. 7 is a detail sectional view showing the means for clamping the frictional guard-plate.

This invention has relation to tobacco-cutting machines, and especially to that class of such devices as are designed for shaving "plug" tobacco into chips suitable for use in pipes for smoking; and it consists in the novel construction and combination of parts hereinafter described.

In the accompanying drawings, illustrating the invention, the letter A designates a disk or wheel having a crank *a* and bearing at its center upon a stud or journal *b*, rigidly mounted near the upper end of the supporting-frame Z. On its inner surface the crank-wheel A carries an annular gear or cog wheel B, revolving therewith. This cog-wheel is arranged to mesh with a second gear-wheel C, loosely mounted on a shaft *c* on the lower portion of the frame, said shaft carrying at its opposite end a disk E, having a wrist-pin and pitman connection with the knife-carrier F, which works in vertically-arranged ways or grooves *f* in the forward upper portion of the frame, thus providing for the vertical reciprocation of the knife when the crank-wheel A is operated.

H represents the horizontal feed-trough supported on the upper rear portion of the frame, and arranged to receive the plug or piece of tobacco to be cut, its forward end terminating

at a point just in rear of the vertical path of the knife. Its forward edge is also beveled, as shown, to form a cutting-edge with the knife. Heretofore in machines for this purpose it has been the practice to provide a constant feed, which has resulted in the knife or cutter-plate becoming clogged or gummed to such an extent as to impede the working of the machine. In the construction of this machine I provide an intermittent feed the gears of which are arranged to operate when the knife or cutter is at its highest elevation, thus obviating this difficulty. This I accomplish by mechanism of the character now to be described.

The disk E has on its periphery the cam projection *h*, adapted at each revolution of the disk to engage and raise a cam-shaped arm or lever K, projecting forward over the cam-disk E, normally held in engagement with its periphery by the spring *k* and limited in its upward movement by the stop *k'*. This arm or lever is carried by a sleeve or collar L, loosely mounted or bearing upon a pin or stud I, projecting laterally from the frame, said sleeve at its opposite end having a second arm M, projecting rearwardly therefrom and carrying an adjustable collar *m*, held thereto by a set pin or screw *m'*. A lug *m''* of the collar *m* is connected by a link *l'* to an arm or lever N, the rear end of which is loosely mounted on a horizontal shaft N', on which is also secured a ratchet-wheel O, and which carries at its inner end a loose pinion P, having the lateral cam-lugs *o*, which are adapted to be engaged by eccentric clutch-rods *o'*, connected to the hub of the ratchet-wheel, so that as said ratchet is operated the pinion will also be revolved through a corresponding arc. A horizontally-arranged rack-bar Q is engaged by this pinion, and this rack-bar is connected through the longitudinal slot *h''* of the feed-trough to a feed or follower plate R, arranged in the feed slide or trough H, so that as the rack-bar is operated by the ratchet mechanism and pinion a forward movement of intermittent character will be given said plate.

The ratchet-wheel O is operated by the spring-pawl *p*, carried by the lever-arm N. It will therefore be seen that each revolution of the disk E will by means of the cam projection thereon and the lever-and-pawl mechan-

ism give a forward movement of one tooth to the ratchet-wheel, which, by means of the pinion P and rack-bar Q, will give a corresponding intermittent forward throw to the feed plate or follower, and as the cam projection of the disk is located on the periphery at a point corresponding to its pitman connection with the knife-carrier such throw will be given when the knife is at its greatest elevation.

It will also be apparent that whichever way the crank-wheel is turned the disk E will be operated to give a forward movement to the feed mechanism by means of the connections described. A spring-pawl *i* prevents the ratchet O from backward movement. By moving the collar *m* on the lever-arm M the length of feed may be adjusted to make either a fine or coarse cutting, as may be desired.

To automatically return the feed-plate or follower when it has reached the limit of its feed, a lever S is provided, being pivoted at its rear end to the under side of the feed-trough H, and having at its forward end a beveled projection *s*, extending past the edge of the slot *h''* and normally held in such position by a spring *s'*. At its intermediate portion this lever carries a bifurcated portion or fork T, which engages a groove *t* in a clutch-section T', loosely mounted on the shaft N', between the ratchet and pinion, and having perforations through which pass the eccentric clutch rods or pins *o'*, which engage the clutched lugs *o* of the pinion P. When the rack has reached the limit of its forward movement, its forward portion will strike against the projection *s* of the lever S, giving said lever a lateral outward movement, which, by means of the fork T, will give the clutch T' a lateral movement on the shaft N', the eccentric clutch-rods *o'* having an endwise movement in the hub of the ratchet, in which position the said clutch will be caught and held by the spring-catch lever T''. As the eccentric clutch-rods are withdrawn from engagement with the lugs *o* by this movement, the pinion no longer has a connection with the ratchet and the rack-bar is immediately returned to its starting-point by means of a spring U, or it may be by means of a suitable weight connected to said bar. As soon as it returns to this position a pin *v*, carried thereby, will engage the forward end of the spring-catch lever T'', releasing it from the clutch-section, the spring *s'* acting upon the lever S, returning it to its normal position and once more setting the parts in gear for a forward feed.

Instead of the clutch-rods *o'*, the clutch T' may be provided with lateral lugs *o''*, as shown in Fig. 5, adapted to clutch the lugs *o*, the opposite end of said clutch-section having a lug or pin adapted to have an endwise movement in a recess in the hub of the ratchet. The shaft N' has a shoulder *n*, which engages the sleeve of the pinion P and prevents its lateral movement thereon.

If it is desired to adjust the follower or feed-plate to a smaller-sized piece of tobacco, this

may be done with the operation of the actuating-gear by simply pressing on the thumb-lug *g'* of said plate, the ratchet turning loosely and permitting the plate to be slid to the desired adjustment.

Secured to the forward end of the feed-trough on either side are the vertically-slotted parallel arms B', between which is adapted to work a frictional guard-plate B'', and through the vertical arms *b'* of this plate is passed a rod C', the ends of which extend through the slots in the arms B'. When it is desired to put a piece of tobacco in the trough, this plate is raised between the slotted arms and falls by its weight upon the tobacco, where it is held by turning a thumb-pin on the rod C', which, by means of the collar *c''* and its threaded engagement with a squared nut *c'* on one of the slotted arms, will clamp the plate securely in place. By means of this plate the tobacco will be held squarely to the cutter and will be stopped from being raised by the upward movement of the knife. The cut tobacco falls out through the opening D in the knife-carrier into the discharge-chute D', secured to the forward part of the frame.

The cutter-carrier F, as hereinbefore stated, works in vertically-angular ways or grooves *f* in the forward portion of the frame, and comprises a rectangular frame having the opening D therein. The face *f''* of the back plate of the carrier, against which the knife F' is held, is beveled upwardly to a slight extent, so as to incline the knife slightly and prevent its cramping against the tobacco. The knife is held between the shoulders *h'* of the back plate H', and its correct adjustment is provided for by means of a stop-pin *e*, which engages a small shoulder *e'* in one corner of the knife, which may be easily removed for sharpening.

As before stated, the wrist-pin of the cam-disk, to which the cutter-actuating pitman is connected is so arranged with relation to the cam projection that whichever way said disk is turned the cam-lever K, which is of double concave form, will be operated to give a forward intermittent feed to the follower-plate, and this at the time when the knife is at its greatest elevation.

The foot Z' of the frame Z is perforated to permit the machine to be secured to a suitable base or support.

Having thus described the invention, what I claim as new, and desire to secure by Letters Patent, is—

1. In a tobacco-cutter, the combination, with the feed-gear, of the cutter-operating mechanism having a projection intermittently engaging and operating said feed-gear when the cutter is operated, said projection being so arranged that the feed-gear will be operated when the cutter is at its highest point, and means for automatically returning the feed-plate of the feed-gear, substantially as specified.

2. In a tobacco-cutter, the combination, with the disk having a cam projection thereon and means for operating said disk, of the double concave arm engaged intermittently by said cam, a sleeve operated by said arm, a second arm connected to said sleeve, a collar adjustably held on said latter arm, a feed-plate, a rack connected to said feed-plate, and a connection between said adjustable collar and the rack, whereby the feed-plate is operated, substantially as specified.

3. The combination, with the feed-plate and means for its forward intermittent movement, of the lever having a projection engaged by said feed-plate when the latter is at the limit of its forward movement, a fork carried by said lever, a movable clutch engaged by said fork and mounted on the actuating pinion-shaft, means carried by said clutch for throwing the feed-plate mechanism out of gear, an automatic catch for retaining it in such position, means for returning said feed-plate, and means for releasing said catch and returning said parts to their normal position as said feed-plate is returned, substantially as specified.

4. The combination, with the feed-trough and the feed-plate arranged to reciprocate therein, of the mechanism for actuating said feed-plate, comprising the rack-and-pinion and the cam-and-lever devices, the clutch-and-lever mechanism operated by said plate to release it when it has reached the limit of its feed, and means for returning said feed-plate to its normal position when so released, substantially as specified.

5. In a tobacco-cutter, the combination, with the feed-trough and the feed-plate working therein, of the vertically-slotted parallel arms secured to said trough, a horizontal frictional guard-plate working between said arms, and a rod held in the slots of said arms and provided with clamps for securing said plate at the desired adjustment, substantially as specified.

6. In a tobacco-cutting machine, the disk E, the cutter-reciprocating pitman connected thereto, the vertically-reciprocating cutter, and the cam projection located on said disk

and intermittently engaging and actuating the feed mechanism when the cutter is operated, and means for operating said disk, in combination with the feed mechanism and means for automatically releasing and returning the feed-plate of said feed mechanism when it has reached the limit of its forward movement, substantially as specified.

7. The tobacco-cutter having the horizontal feed-trough, the feed-plate working in said trough at right angles to the plane of the path of the cutter, its rack-bar, the pinion and ratchet, and the cam-and-lever mechanism actuated by the cutter-actuating gear for operating said ratchet, rack, and pinion, in combination with the lever, clutch-and-stop mechanism for releasing said feed-plate when it has reached the limit of its feed and throwing it out of gear with its actuating mechanism, and means for returning said plate when so released, substantially as specified.

8. In a tobacco-cutting machine, the combination, with the disk E, having the cutter-reciprocating pitman connected therewith, and the cam projection thereon, arranged to engage the feed mechanism when the cutter is at its highest point, of the double-concave cam-lever operated by said projection, the feed mechanism operated by said lever, and the clutch-and-lever mechanism operated by the feed-slide plate to release it when it has reached the limit of its movement, and means for returning said plate to its normal position, substantially as specified.

9. A crank-driven tobacco-cutting machine having an intermittent and automatically-reversing adjustable feed, a disk carrying a cam arranged to operate said feed, said disk also having a wrist-and-pitman connection with a reciprocating-cutter carrier, substantially as specified.

In testimony whereof I affix my signature in presence of two witnesses.

JOHN BLAKE TARR.

Witnesses:

PHILIP C. MASI,
CHAS. L. TAYLOR.