

(19) **DANMARK**



Patent- og
Varemærkestyrelsen

(10) **DK/EP 2119864 T3**

(12) **Oversættelse af
europæisk patentskrift**

-
- (51) Int.Cl.: **E 06 B 3/54 (2006.01)** **E 06 B 3/92 (2006.01)**
- (45) Oversættelsen bekendtgjort den: **2016-09-19**
- (80) Dato for Den Europæiske Patentmyndigheds bekendtgørelse om meddelelse af patentet: **2016-06-22**
- (86) Europæisk ansøgning nr.: **09397514.2**
- (86) Europæisk indleveringsdag: **2009-05-13**
- (87) Den europæiske ansøgnings publiceringsdag: **2009-11-18**
- (30) Prioritet: **2008-05-15 FI 20085454**
- (84) Designerede stater: **AT BE BG CH CY CZ DE DK EE ES FI FR GB GR HR HU IE IS IT LI LT LU LV MC MK MT NL NO PL PT RO SE SI SK TR**
- (73) Patenthaver: **Lumon Invest Oy, Kaitilankatu 11, 45130 Kouvola, Finland**
- (72) Opfinder: **Lehtonen, Markku, Kiviranta 5, 45700 Kuusankoski, Finland**
- (74) Fuldmægtig i Danmark: **PATRADE A/S, Fredens Torv 3A, 8000 Århus C, Danmark**
- (54) Benævnelse: **Glasholdeliste til snapmontering på kanten af et glaspanel**
- (56) Fremdragne publikationer:
US-A- 5 373 672

DESCRIPTION

[0001] The invention relates to a profile bar to be locked to a panel. The invention relates to the panel structure of a glazing system.

[0002] Glazing systems of prior art, which are used, among other things, in balconies, are installed in buildings. The systems typically comprise an upper profile and a lower profile, which are used as guide tracks and inside which the necessary movable guide track parts are placed, between which, in turn, the single glass panes are suspended. The glass panes form walls and doors, as well as limit the space or protect it, for example, from weather conditions, for example on balconies or terraces, or divide the space into several parts and section off spaces, for example in rooms or business facilities. Typically, the profiles extend in the horizontal direction and are fastened to the structures of the building. By means of guide track parts, the single glass panes can be moved and also opened and closed around a vertical axis of rotation. The glass panes can be transferred and bunched up when opened. Some known glazing systems are disclosed, for example, in documents EP 1892362 A1 and EP 188996 A1.

[0003] Glass panes, or corresponding panels, are normally unconnected, and when the panel is turned, the guide member of the panel must be locked into place so that the panel will not assume an inclined position. During the locking, the guide member is locked, for example, to an adjacent guide member, according to WO 03/042482 A1, or, for example, to a locking member inside an upper profile, which is, for example, a socket or a form, in which the guide member or a part of it is placed during the turning of the panel.

[0004] The panels typically comprise profile bars which are normally provided at both the upper edge and the lower edge of the panel. The profile bar is normally an aluminium profile made by extrusion. The guide members and, if necessary, also guides, are attached to the profile bar.

[0005] The profile bars are normally fixed to the panels in such a way that the panel is placed in a slot in the profile bar, and the profile bar is kept in place by compression. Normally, the fixing is also secured by means of glue and fixing members, for example screws, extending through a hole made in the panel. Some examples of profile bars and their fixing are disclosed in WO 03/040505 A1, WO 03/040510 A1 and WO 02/29177 A1.

[0006] The fixing of a profile bar to a glass pane may turn out to be a time consuming and laborious operation. Problems may be caused, for example, by the machining of holes in the glass pane, because for the time of making the holes, the glass pane which is transferred e.g. by means of a conveyor in a factory or a workshop, must be stopped and aligned with precision in two perpendicular directions, which slows down the manufacturing process. It is difficult to combine these steps, for example, with the grinding of the edges or other processing of the glass panes to a single efficient operation. The use of screws will secure the fixing of the profile bar to the glass pane but also slow down the installation work.

[0007] Document US-A-5373672 shows an example of a mounting section fixed to a glass pane. The mounting section may be pre-bent and have elevations to lock the glass pane in place.

[0008] A solution will be presented to eliminate problems presented above. More precisely, the profile bar to be locked to panel according to the inventive solution will be presented in claim 1. The panel structure for a glazing system according to the inventive solution will be presented in claim 4.

[0009] The solution will enable the attachment of the profile bar to a glass pane or a panel in a way that is easy and fast with respect to the installation. The solution will enable the processing of glass panes for fastenings, for example, in a factory in such a way that the processing method is significantly faster than the methods of prior art. The new processing method can be easily integrated in other processing of the glass panes. Yet another significant advantage is the secure way of fixing the profile bar, so that it will not be necessary to use securing screws.

[0010] Yet another significant advantage in an example of the solution is the fact that the fixing of the profile bar to a glass pane or panel by pressing requires less force than the detachment of the profile bar by pulling in the opposite direction. As a result, the installation is easy and the fixing is secure and safe.

[0011] Yet another advantage in some examples of the solution is the fact that the installation of the profile bar on the glass pane and its detachment can also be performed by sliding in the direction of the profile bar.

[0012] In an example of the solution, the glass pane comprises locking shapes, particularly one or more grooves or open

channels, in which the locking members of the profile bar are placed. Preferably, the profile bar comprises a structure that presses the glass pane against the locking members. Said structure and/or locking member can be selected so that they yield during the installation. In another example of the solution, the profile bar to be utilized comprises an elastic locking member which is a protrusion and is placed in a shape in the glass pane and efficiently prevents the pulling out of the glass pane.

[0013] A particular advantage of the solution is the fact that the machining of the locking shape in the glass pane will not require the stopping of the glass pane, which speeds up the processing methods to a significant extent. The alignment of the glass pane in connection with the machining of the locking shape is facilitated to a significant extent, because it will suffice that one end surface of the glass pane is placed accurately and in a desired way, for example, against a stopper for the time of the machining.

[0014] The solution can be applied in glazing systems which are used outdoors or indoors. The solution can also be applied in various systems in which different panels and panel materials are utilized.

[0015] The solution will be illustrated in the following description by means of some examples and with reference to the appended drawings, in which:

Fig. 1 shows a glazing system according to a known example in a principle view,

Fig. 2 shows a profile bar according to an example of the solution in a cross-sectional view,

Fig. 3 shows a profile bar which does not belong to the present invention in a cross-sectional view,

Fig. 4 shows a panel or a glass pane according to an example of the solution,

Fig. 5 shows a profile bar according to Fig. 2 and a glass pane according to Fig. 4, fixed to each other,

Fig. 6 shows a cover according to an example of the solution and

Fig. 7 shows a profile bar according to Fig. 2, a glass pane according to Fig. 4, and a cover according to Fig. 6, fixed to each other.

[0016] Figure 1 shows a panel and a panel system of prior art that is simultaneously, for example, a glazing system for e.g. balconies, or a wall limiting a space. The system normally comprises several successive glass panes which are movable. The panels 1 are normally rectangular, wherein they are normally in an upright position and form a closed wall or a large window when placed one after the other. They can be transferred in the direction of the guide tracks, which is typically the horizontal direction. The panels 1 can be opened into a position which is normally perpendicular to the closed position shown in Fig. 1. In the open position, the panels 1 may be placed close to each other, wherein they may be stored, for example, on one side of a balcony, where they have first been moved along the guide tracks. The upper guide track 3 and the lower guide track 2 are placed in the horizontal direction and, among other things, an upper guide track part 4 and a lower guide track part 5 are placed inside them and are movable in the guide tracks, the panels 1 being fixed from above and from below between the guide track parts, and the panel is in the vertical plane. The guide tracks are normally extruded profiles made of aluminium and provided with a long continuous slot or channel for the guide track parts. The panel 1 is preferably formed by a glass pane whose lower and upper edges are provided with profile bars 7 and 8, to which, in turn, the guide members 4, 5 and 9 are fixed, for example, by means of hinge pins 6, 11 and 15 or shafts.

[0017] In the guide members and their lockings, it is possible to apply various solutions of prior art. The panel 1 and/or the guide tracks 3, 4 are equipped with guiding members and means of prior art, for example guiding members 13, 14 and stoppers 10 and 12, whose functionality facilitates or secures the locking of the panel into place, so that the panel can be turned fully open. For opening the panel 1, an opening 16 is provided at the side of the guide track 3, through which the guide track part 9 can come out of the guide track during the turning.

[0018] Figure 2 shows an extruded aluminium profile according to the presented example that is utilized as a profile bar to be fixed to the panel, for example in the system shown in Fig. 1. The shapes of the profile, visible in the cross-section, extend uniformly in the longitudinal direction of the profile. Different parts of the system, particularly the hinge pin, are fixed to an elongated slot 19 or channel. The profile bar 20 also comprises an elongated slot 21 or channel for the panel, placed on the opposite side of the profile bar 20 with respect to the slot 19. The side walls 21 a and 21 b limiting the slot 21 are placed against the side surfaces 22a and 22b of the panel or glass pane 22 (see Fig. 4), and the transverse end wall 21 c is placed against the narrow transverse end surface 22c of the glass pane 22, close to it or spaced from it. Furthermore, the slot 21 comprises an

opening 18, through which the panel is installed. The end wall 21 c and the end surface 22c are preferably parallel. Furthermore, the profile bar 20 comprises a varying number of other walls which are adjacent to the side walls 21 a, 21 b or the end wall 21 c and, if necessary, parallel with them. Normally, the profile bar comprises outer walls 20a and 20b which are connected in a seamless manner via necks to the side walls and the end wall and which are also profiled, if necessary. Closed or open chambers are left between the walls. It is also possible that, for example, the side wall 21 a is simultaneously the outer wall of the profile bar 20.

[0019] In the example of Fig. 2, the side wall 21 b is an elastic structure and it is simultaneously a locking member for locking the panel or glass pane 22 into place. The side wall 21 b is placed in a groove 25 machined in the glass pane and mechanically prevents the detachment of the glass pane. The side wall 21 b is connected as a protrusion to the profile bar 20 and extends from the opening 18 towards the end wall 21 c, substantially in the direction of the side wall 21 a and the glass pane installed in the slot 21. Simultaneously, the side wall 21 b extends towards the end surface 22c of the glass pane. The end 23 of the side wall 21 b is free and capable of moving by bending in a direction substantially perpendicular to the side wall 21a and the glass pane. The slot 21 is dimensioned so that the installation of the glass pane in the slot by pressing will force the end 23 to yield, which increases the friction between the glass pane and the end 23. The perpendicular distance between the free end 23 and the side wall 21 a is thus smaller than the thickness of the panel or the glass pane.

[0020] The locking of the panel or glass pane in its place takes actually place so that the end 23 is placed in a groove 25 in the glass pane 22 (see Fig. 4). To remove the glass pane, in turn, a greater force will be needed, because when the glass pane is lifted off the profile bar 20, the end 23 is strongly supported to the groove 25. The shapes of the groove 25 and the end 23 are matched so that the groove 25 does not push the end 23 to the side but they are set tightly against each other. The shapes can be matched so that a given, relatively great force will be needed to move the end 23 off the groove 25, or the side wall 21 b would otherwise, by yielding, allow such a movement of the end 23 that would shift the end 23 off the groove 25. The shapes can even be selected so that the end 23 comes tighter against the glass pane 22 rather than transversely away from it. The yielding is also influenced by the length of the side wall 21 b and the thickness of the material. The locking can be enhanced by supplementing the side wall 21 b with, for example, ridges which correspond to the end 23 in its shape and functionality and which are placed in grooves in the panel or glass pane.

[0021] The side wall 21 a is attached at its both ends to the profile bar 20, but even this can be arranged so that it will yield during the installation of the panel or glass pane. The side wall 21a may also be provided with ridges that are placed in grooves in the panel. Typically, a layer of glue is applied between the side wall 21 a and the panel, to secure the locking.

[0022] Figure 3 shows an extruded aluminium profile according to another example, however, not belonging to the present invention, that is utilized as a profile bar 20 to be fixed to the panel or glass pane, for example in the system shown in Fig. 1. Because of the similarity in the functionality, reference numerals corresponding to those of Fig. 2 are used. In this example, the side wall 21 b is an elastic structure that yields in a direction substantially perpendicular to the side wall 21 a and the glass pane, or a normal side wall that only yields to some extent or not at all. The side wall 21 b is also a locking member that locks the panel into place. The side wall 21 b is placed in a corresponding groove 25 machined in the panel or glass pane 22 (see Fig. 4) and prevents the detachment of the panel mechanically. The side wall 21 b comprises one or more ridges 24 placed in a groove 25 in the panel or glass pane. The side wall 21 b is attached at its both ends to the profile bar 20 and is substantially parallel to the side wall 21 a and, for example, the glass pane 22. One or more ridges 24 are provided in the central part of the side wall 21 b.

[0023] In the example of Fig. 3, the side wall 21 a is an elastic structure that yields in a direction substantially perpendicular to the side wall 21 b. The side wall 21 b is attached at its both ends to the profile bar 20, and the ridge 24 or ridges are placed substantially at the height of the centre of the side wall 21 a. The slot 21 is dimensioned so that the installation of the panel in the slot 21 by pressing will force the side wall 21 a to yield, which increases the friction between the panel and the side wall 21 a. The perpendicular distance between the ridge 24 and the side wall 21 a is thus smaller than the thickness of the panel. A glass pane 22 according to Fig. 4 is locked into place in such a way that the ridge 24 is placed in the groove 25 in the glass pane 22. During the installation, the side wall 21 a or the side wall 21 b yields, or they both yield, or the whole profile bar 20 yields, depending on the structure of the profile bar. A sufficient force will be needed for removing the glass pane 22, because when the glass pane 22 is lifted off the profile bar 20, the ridge 24 is in the groove 25. The shape of the groove and the ridge can be matched in such a way that the lifting of the glass pane off the profile bar will require a greater force than its installation. The shape can be fitted so that a relatively great force is needed to remove the ridge from the groove. The yielding is also influenced by the length and the thickness of the side wall. The locking can also be enhanced by supplementing the side wall 21 a with ridges which match with the ridge 24 in their shape and functionality and which are placed in grooves in the panel or glass pane. In this case, grooves whose functionality corresponds to the groove 25 are provided on both sides of the glass pane. In view of the strength of the glass pane, grooves are preferably provided on one side surface of the glass pane only.

[0024] Figure 4 shows a glass pane 22 that is utilized, among other things, as a panel, for example in the system of Fig. 1, and to which for example a profile bar according to Fig. 2 or 3 is fixed. The glass pane 22 is typically rectangular in shape, and, for example, its end surface 22c is preferably perpendicular to the side surfaces 22a and 22b. The glass pane 22 is made by cutting, and its edges 17 which are placed in the intersections of the side surfaces and the end surface, are typically grounded to an angle of about 45 degrees. The glass pane 22 also comprises two other perpendicular end surfaces, of which the end surface 22d is shown.

[0025] According to prior art, cylindrical holes are generally drilled in the glass pane which extend through the glass pane in the perpendicular direction and which are utilized in fixings that fix the glass pane to a profile bar by means of, for example, screws. The glass pane 22 according to the example of Fig. 4 comprises an engraving, a channel or a groove 25, by means of which the glass pane 22 is fastened to the profile bar 20. The groove 25 is straight and long or elongated, wherein its length in the direction of the end surface 22c is greater or multiple in relation to the width of the groove 25. There may be several grooves, and they are parallel, as sketched by a broken line in Fig. 4. The groove is made by machining the glass pane by means of, for example, a rotating diamond wheel. The groove can also be made in another way, for example by means of a broaching tool, so that the cross-sectional shape of the groove may vary and comprise round, curved or straight walls, according to the need. As a process, the machining may be continuous, if the groove is continuous and extends from one edge of the glass pane to another, that is, over the side surface 22a to the end surface 22d, so that the glass pane does not need to be stopped for the time of the machining. With respect to the machining process, it will be sufficient that for example the side surface 22c is placed against an aligning stopper, along which the end surface 22c glides or rolls at the same time when the glass pane 22 moves and a tool machines the glass pane passing by. In this case, the tool may be stationary, but it is obviously also possible to use a moving tool and to stop the glass pane for the time of the machining. In spite of the stopping, the process is faster than the known technique, because the alignment is simple.

[0026] The groove 25 is preferably continuous and open at least at one end, wherein the installation of the profile bar to the glass pane 22 is also possible by pushing the profile bar onto the glass pane by a movement that is parallel with the groove 25. The groove 25 is preferably open at its both ends, as shown in Fig. 4. Thus, it will not be necessary to stop the glass pane or lift up the tool during the machining and when the glass pane is moving, and it will not be necessary to align the tool accurately to the starting and end points of the groove. Preferably, the groove 25 is continuous in the longitudinal direction of the profile bar 20, as are also the locking structures and shapes in the profile bar 2; the end 23 and the ridge 24 serving as examples. The perpendicular distance of the groove 25 from the end surface 22c is substantially equal to or shorter than the distance between the end 23 or the ridge 24 and the end surface 21 c.

[0027] The groove 25 may also consist of two or more successive and parallel grooves, but in this case, the portion that is placed between the successive grooves must be removed from the side wall 21 b, the end 23 or the ridge 24 of the profile bar 20, for example by cutting or drilling. Alternatively, the profile bar consists of several parts to be placed one after the other, which may differ from each other in their cross-section, method of fastening, and structure.

[0028] In an example, the open end of the profile bar 20 is closed with a cover 26 shown in Fig. 6, which is normally a cover, a plug or a lid made of plastic. The cover comprises protrusions 26a and 26b which are connected for example by means of friction to the walls or chambers in the profile bar. Furthermore, the cover comprises a wedge 27 whose thicker end is attached to the cover and whose sharper end extends away from the cover, substantially in the perpendicular direction. The wedge 27 is pushed underneath the panel or glass pane, being placed, for example, between the end surface 22c of the glass pane 22 and the end wall 21 c. When the cover 26 is inserted, the wedge 27 pushes the glass pane 22 upwards and the wedge 25 is placed tightly against either the end 23 or the ridge 23. The attachment presented will remove any clearance between the profile bar and the panel, and the profile bar cannot move in a useless manner with respect to the panel. The cover 26 of Fig. 6 also comprises a slot 26c open on top and on one side for receiving a corner of the glass pane 22.

[0029] Figure 7 shows a panel structure according to an example, which is utilized, for example, in a system according to Fig. 1. The panel structure 28 comprises a panel or glass pane 22, a profile bar 20 and a cover 26 as presented above. The total length of the profile bar 20 may be smaller than the width of the glass pane 22. In the example of Fig. 7, the profile bar 20 does not extend all the way to the end surface, because a cover 26 is provided at the corner of the glass pane.

[0030] Figure 5 shows a profile bar 20 of Fig. 1 and a glass pane 22 of Fig. 4 fixed to each other. As shown in Fig. 5, the end 23 is placed in the groove 25 in the glass pane 22. The functionality of the locking is presented in more detail in the description relating to Fig. 2.

[0031] The invention is not restricted solely to the embodiments presented above. The invention is applied within the scope of

the appended claims. The material for manufacturing the panel is selected according to the need, and it may comprise transparent or opaque alternatives. In this specification, particularly a variant made of glass is disclosed. The shapes and more accurate dimensions of the profile bar and the profiles may vary as desired.

REFERENCES CITED IN THE DESCRIPTION

This list of references cited by the applicant is for the reader's convenience only. It does not form part of the European patent document. Even though great care has been taken in compiling the references, errors or omissions cannot be excluded and the EPO disclaims all liability in this regard.

Patent documents cited in the description

- [EP1892362A1 \[0002\]](#)
- [EP189996A1 \[0002\]](#)
- [WO03042482A1 \[0003\]](#)
- [WO03040505A1 \[0005\]](#)
- [WO03040510A1 \[0005\]](#)
- [WO0229177A1 \[0005\]](#)
- [US5373672A \[0007\]](#)

Patentkrav

1. Profilliste til låsning til et panel, omfattende:

- en profilform (20), der strækker sig i længderetningen,
- 5 - en spalte (21) med en lang åbning (18) til installering af panelet,
- en første sidevæg (21b), som begrænser spalten og er placeret på den første side af panelet, der skal placeres i spalten,
- en anden sidevæg (21a), som begrænser spalten på modsat side i forhold til den første sidevæg (21b) og er placeret på den anden side af panelet, der skal
- 10 placeres i spalten, og
- en tværgående endevæg (21c), der begrænser spalten,

kendetegnet ved, at

- den første sidevæg (21b) er et elastisk fremspring, der strækker sig væk fra
- 15 åbningen (18) mod endevæggen (21c) i det væsentlige i retning af den anden sidevæg (21a) og med en fri ende (23), der kan bevæges ved bøjning i retning i det væsentlige vinkelret på den anden sidevæg (21a) og panelet, der skal placeres i spalten, og hvilken fri ende (23), takket være sin egenelasticitet, giver efter, når den presses mod panelet, der skal placeres i spalten.

20 2. Profilliste ifølge krav 1, **kendetegnet ved, at** den frie ende (23) er indrettet til at placeres i et spor på en sideflade af panelet, når panelet er i positionen installeret i spalten (21).

25 3. Profilliste ifølge krav 2, **kendetegnet ved, at** den frie endes (23) form og sporets form er funktionsmæssigt indbyrdes tilpasset for at låse panelet i spalten.

4. Panelkonstruktion til et glassystem, omfattende:

- et panel (22) lavet af et glasmateriale, omfattende en første sideflade (22a) og en anden sideflade (22b), som er parallelle, og en endeflade (22c), som er placeret mellem sidefladerne og med hvilken sidefladerne er begrænset,
- 30 - hvori panelet (22) yderligere omfatter et langt spor (25) tilvejebragt i den første sideflade (22a) i det væsentlige parallelt med endefluden (22c),
- en profilliste til at låses til panelet (22), hvilken profilliste har en profilform (20), der strækker sig i profillistens længderetning, omfattende en spalte (21) med en
- 35 lang åbning (18) til installering af panelet og en første sidevæg (21b), som begrænser spalten og er placeret mod den første sideflade (22a) af panelet placeret i spalten,

- hvori profillisten (20) yderligere omfatter en anden sidevæg (21a), som begrænser spalten på modsat side i forhold til den første sidevæg (21b) og er placeret på den anden side af panelet placeret i spalten,

5 - hvori profillisten (20) yderligere omfatter en tværgående endevæg (21c), der begrænser spalten, og

- hvori profillisten (20) yderligere omfatter mindst en låsedannende del, som er tilvejebragt på den første sidevæg (21b) og placeret i sporet (25),

kendetegnet ved, at

10 - den låsedannende del er den første sidevæg (21b), som er et elastisk fremspring, der strækker sig væk fra åbningen (18) mod endevæggen (21c) i det væsentlige i retning af den anden sidevæg (21a) og med en fri ende (23) placeret i sporet (25), som er i stand til at bevæges ved bøjning i retning i det væsentlige vinkelret på den anden sidevæg (21a) og panelet placeret i spalten, og hvilken fri ende (23), takket være sin egenelasticitet, giver efter, når den presses mod panelet placeret i spalten.

5. Panelkonstruktion ifølge krav 4, **kendetegnet ved, at** profillisten (20) yderligere omfatter en ydervæg (20b) tilstødende den første sidevæg (21b) og på sømløs måde forbundet via kraver med den første sidevæg (21b) og endevæggen (21c), hvori et lukket eller åbent kammer er efterladt mellem væggene.

6. Panelkonstruktion ifølge krav 5, **kendetegnet ved, at** profillisten yderligere omfatter en anden ydervæg (20a) tilstødende den første sidevæg (21a) og på sømløs måde forbundet via kraver med den anden sidevæg (21a) og endevæggen (21c), hvori et lukket eller åbent kammer er efterladt mellem væggene.

7. Panelkonstruktion ifølge ethvert af krav 4 til 6, **kendetegnet ved, at** profillisten omfatter mindst en afdækning (26), der dækker en ende af profillisten og omfatter en kile (27), som er indrettet til at skubbes mellem endefladerne (22c) og endevæggen (21c) af profillisten og skubbe glaspanelet (22) opad for at fjerne spillerum mellem profillisten og panelet.

8. Panelkonstruktion ifølge krav 7, **kendetegnet ved, at** afdækningen omfatter fremspring (26a, 26b), som ved friktion er forbundet med vægge eller kamre i profillisten.

35

9. Panelkonstruktion ifølge krav 7 eller 8, **kendetegnet ved, at** afdækningen yderligere omfatter en spalte (26c), som er åben foroven og på en side for optagelse af et hjørne af panelet (22).

DRAWINGS

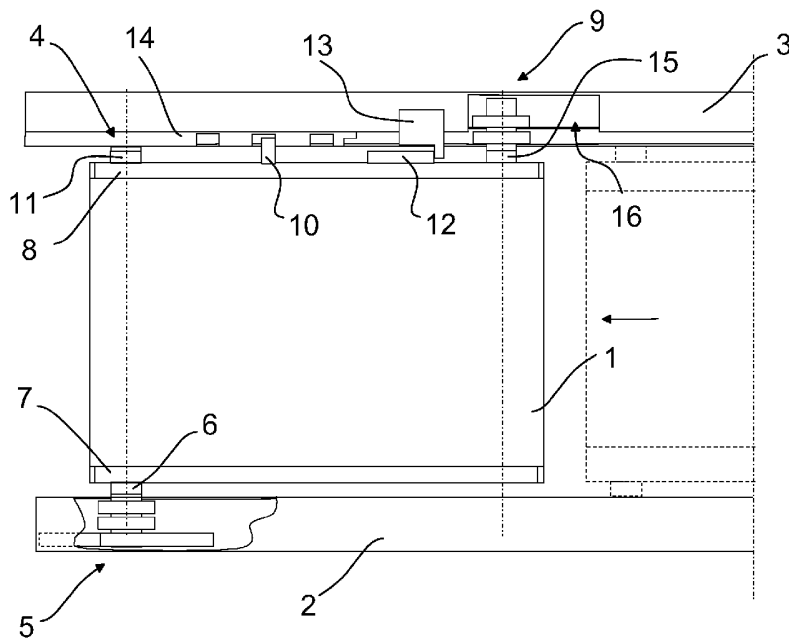

Fig. 1

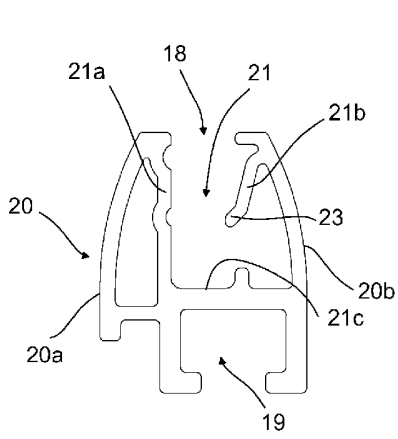

Fig. 2

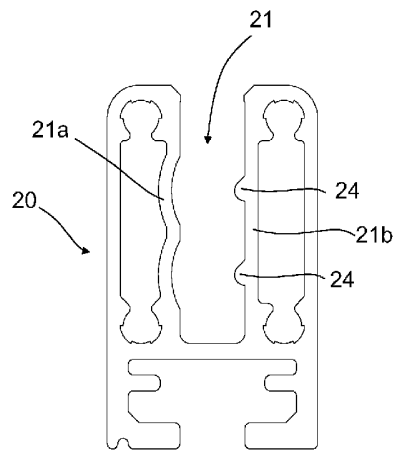
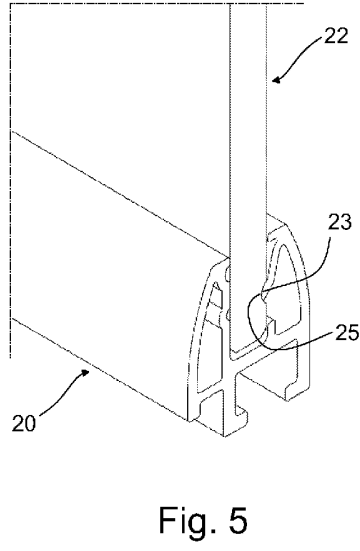
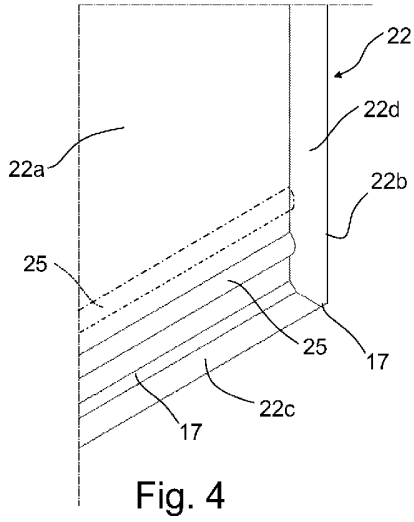

Fig. 3



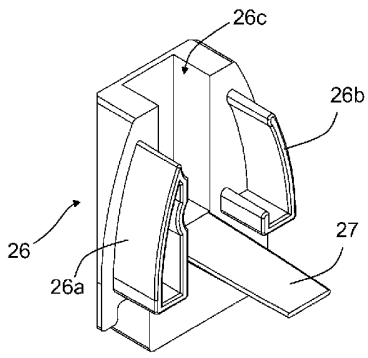

Fig. 6

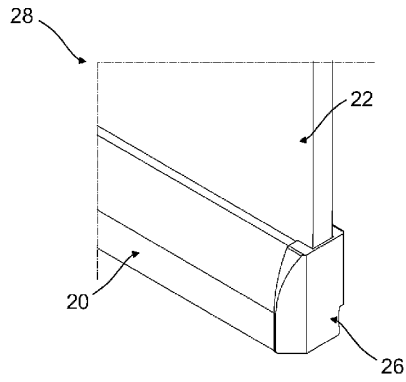

Fig. 7