



- (51) International Patent Classification:  
*H04L 27/26* (2006.01)    *H04B 7/04* (2006.01)
- (21) International Application Number:  
PCT/US2015/024889
- (22) International Filing Date:  
8 April 2015 (08.04.2015)
- (25) Filing Language: English
- (26) Publication Language: English
- (30) Priority Data:  
61/990,414    8 May 2014 (08.05.2014)    US  
14/498,385    26 September 2014 (26.09.2014)    US
- (63) Related by continuation (CON) or continuation-in-part (CIP) to earlier application:  
US    14/498,385 (CON)  
Filed on    26 September 2014 (26.09.2014)
- (72) Inventors; and
- (71) Applicants : **LI, Guoqing C.** [CN/US]; 3672 NW Talamore TER, Portland, Oregon 97229 (US). **STACEY, Robert J.** [US/US]; 2537 SE Stephens St., Portland, Oregon 97214 (US).

- (74) Agents: **MADDEN, Robert B.** et al.; SCHWEGMAN LUNDBERG & WOESSNER, P.A., P.O. Box 2938, Minneapolis, Minnesota 55402 (US).
- (81) Designated States (unless otherwise indicated, for every kind of national protection available): AE, AG, AL, AM, AO, AT, AU, AZ, BA, BB, BG, BH, BN, BR, BW, BY, BZ, CA, CH, CL, CN, CO, CR, CU, CZ, DE, DK, DM, DO, DZ, EC, EE, EG, ES, FI, GB, GD, GE, GH, GM, GT, HN, HR, HU, ID, IL, IN, IR, IS, JP, KE, KG, KN, KP, KR, KZ, LA, LC, LK, LR, LS, LU, LY, MA, MD, ME, MG, MK, MN, MW, MX, MY, MZ, NA, NG, NI, NO, NZ, OM, PA, PE, PG, PH, PL, PT, QA, RO, RS, RU, RW, SA, SC, SD, SE, SG, SK, SL, SM, ST, SV, SY, TH, TJ, TM, TN, TR, TT, TZ, UA, UG, US, UZ, VC, VN, ZA, ZM, ZW.
- (84) Designated States (unless otherwise indicated, for every kind of regional protection available): ARIPO (BW, GH, GM, KE, LR, LS, MW, MZ, NA, RW, SD, SL, ST, SZ, TZ, UG, ZM, ZW), Eurasian (AM, AZ, BY, KG, KZ, RU, TJ, TM), European (AL, AT, BE, BG, CH, CY, CZ, DE, DK, EE, ES, FI, FR, GB, GR, HR, HU, IE, IS, IT, LT, LU, LV, MC, MK, MT, NL, NO, PL, PT, RO, RS, SE, SI, SK, SM, TR), OAPI (BF, BJ, CF, CG, CI, CM, GA, GN, GQ, GW, KM, ML, MR, NE, SN, TD, TG).

[Continued on next page]

(54) Title: METHOD, APPARATUS, AND COMPUTER READABLE MEDIA FOR ACKNOWLEDGEMENT IN WIRELESS NETWORKS

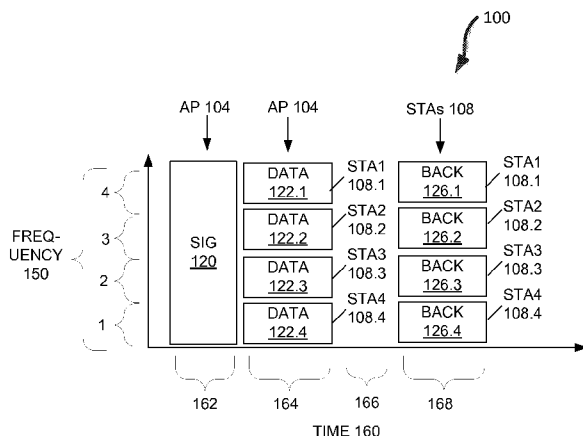


FIG. 2

(57) Abstract: Embodiments of a system and method for communicating acknowledgments in a wireless network are generally described herein. In some embodiments, a method of wirelessly communicating acknowledgements includes receiving a first signal on a first subchannel from a second wireless device. The method may include transmitting a block acknowledgement of the first signal on a subchannel. The first wireless communication device may not receive a block acknowledgement request to transmit the block acknowledgement. In some embodiments, a method of communicating block acknowledgements includes transmitting a first transmission to a first wireless device on a first subchannel and a second transmission to a second wireless device on a second subchannel. The method may include receiving a first block acknowledgement from the first wireless device and a second block acknowledgement from second wireless device. The first and second block acknowledgement may be received on one of the first and second subchannels.

WO 2015/171243 A1

**Published:**

— *with international search report (Art. 21(3))*

METHOD, APPARATUS, AND COMPUTER READABLE MEDIA FOR  
ACKNOWLEDGEMENT IN WIRELESS NETWORKS

5

PRIORITY CLAIM

**[0001]** This application claims the benefit of priority to U.S. Patent Application Serial No. 14/498,385, filed September 26, 2014, and claims the benefit of priority to U.S. Provisional Patent Application Serial No. 61/990,414, filed May 8, 2014, each of which is incorporated herein by reference in its entirety.

15

TECHNICAL FIELD

**[0002]** Embodiments pertain to wireless communications. Some embodiments relate to block acknowledgements in wireless networks.

20

BACKGROUND

**[0003]** One issue with communicating data over a wireless network is acknowledging received data. Often acknowledging received data consumes bandwidth. Moreover, with the use of some protocols, a large number of stations may be transmitting simultaneously in both the spatial domain and time domain. Additionally, consumers often demand more and more bandwidth for their applications.

25

**[0004]** Thus, there are general needs for systems, apparatus, and methods that reduce signaling, bandwidth, and delay associated with communicating smaller amounts of data.

30

## BRIEF DESCRIPTION OF THE DRAWINGS

- [0005] FIG. 1 illustrates a wireless network, in accordance with some embodiments;
- 5 [0006] FIG. 2 illustrates a time sequence diagram of an acknowledgement, in accordance with some example embodiments;
- [0007] FIG. 3 illustrates a time sequence diagram of an acknowledgement, in accordance with some example embodiments;
- [0008] FIG. 4 illustrates a time sequence diagram of an  
10 acknowledgement, in accordance with some example embodiments;
- [0009] FIG. 5 illustrates a time sequence diagram of an acknowledgement, in accordance with some example embodiments;
- [0010] FIG. 6 illustrates a time sequence diagram of an acknowledgement, in accordance with some example embodiments;
- 15 [0011] FIG. 7 illustrates a frame with a field for acknowledgement, in wireless networks according to example embodiments;
- [0012] FIG. 8 illustrates a frame with a field for acknowledgement, in wireless networks according to example embodiments;
- [0013] FIG. 9 illustrates a frame with a field for acknowledgement, in  
20 wireless networks according to example embodiments; and
- [0014] FIG. 10 illustrates a high-efficiency wireless HEW device, in accordance with some embodiments.

## DETAILED DESCRIPTION

- 25 [0015] The following description and the drawings sufficiently illustrate specific embodiments to enable those skilled in the art to practice them. Other embodiments may incorporate structural, logical, electrical, process, and other changes. Portions and features of some embodiments may be included in, or  
30 substituted for, those of other embodiments. Embodiments set forth in the claims encompass all available equivalents of those claims.
- [0016] FIG. 1 illustrates a wireless network, in accordance with some embodiments. The wireless network may comprise a basis service set (BSS) 50

that may include an access point (AP) 104, a plurality of high-efficiency wireless or Wi-Fi (HEW) (e.g., Institute of Electrical and Electronics Engineers IEEE 802.11ax) devices, and a plurality of legacy (e.g., IEEE 802.11n/ac) devices 106.

5 [0017] The AP 104 may be an AP and use 802.11 to transmit and receive. The AP 104 may be a base station. The AP 104 may use other communications protocols as well as the 802.11 protocol. The 802.11 protocol may be 802.11ax. The 802.11 protocol may include using Orthogonal Frequency-Division Multiple Access (OFDMA). The 802.11 may include using multi-user multiple-input and multiple-output (MU-MIMO).

10 [0018] The HEW devices 102 may be wireless transmit and receive devices such as cellular telephones, handheld wireless devices, wireless glasses, wireless watches, wireless personal devices, tablets, or another devices that may be transmitting and receiving using an 802.11 protocol such as 802.11ax or another wireless protocol.

15 [0019] The BSS 50 may operate on a primary channel and one or more secondary channels or sub-channels. The BSS 50 may include one or more APs 104. In accordance with embodiments, the AP 104 may communicate with one or more of the HEW devices 102 on one or more of the secondary channels or sub-channels or the primary channel. In example embodiments, the AP 104  
20 communicates with the legacy devices 106 on the primary channel. In example embodiments, the AP 104 may be configured to communicate concurrently with one or more of the HEW devices 102 on one or more of the secondary channels and a legacy device 106 utilizing only the primary channel and not utilizing any of the secondary channels.

25 [0020] The AP 104 may communicate with legacy devices 106 in accordance with legacy IEEE 802.11 communication techniques. In example embodiments, the AP 104 may also be configured to communicate with HEW devices 102 in accordance with legacy IEEE 802.11 communication techniques. Legacy IEEE 802.11 communication techniques may refer to any IEEE 802.11  
30 communication technique prior to IEEE 802.11ax.

[0021] In some embodiments, HEW frames may be configurable to have the same bandwidth or different bandwidths, and the bandwidth may be one of 20MHz, 40MHz, 80MHz or 160 MHz contiguous bandwidths or an 80+80MHz

non-contiguous bandwidth. In some embodiments, a 320MHz contiguous bandwidth may be used. In some embodiments, bandwidths of 1 MHz, 1.25MHz, 2.5MHz, 5MHz and 10MHz or a combination thereof may also be used. In these embodiments, a HEW frame may be configured for transmitting a number of spatial streams.

**[0022]** In example embodiments, referring to FIGS. 2 through 9, the AP 104 is configured to transmit and/or receive signal fields (SIGs) 120, 220, 320, 420, and 520; DATA 122,222, 322, 422, and 522; (multi-user block acknowledgment requests (MU BAR) 323, 423, and 523; block acknowledgment request (BAR) 223; (block acknowledgment) BACK 226, 326, 426, and 526; frames 600 and 700; and, BACK 126.

**[0023]** In example embodiments the HEW device 102 is configured to transmit and/or receive SIGs 120, 220, 320, 420, and 520; DATA 122,222, 322, 422, and 522; MU BAR 323, 423, and 523; BAR 223; BACK 226, 326, 426, and 526; frames 600 and 700; and, ACK 126. In example embodiments, the HEW device 102 is station (STA) in 802.11.

**[0024]** In other embodiments, the AP 104, HEW device 102, and/or legacy device 106 may implement different technologies such as code-division multiple access (CDMA) 2000, CDMA2000 1X, CDMA2000 EV-DO, Interim Standard 2000 (IS-2000), Interim Standard 95 (IS-95), Interim Standard 856 (IS-856), Global System for Mobile communications (GSM), Enhanced Data rates for GSM Evolution (EDGE), GSM EDGE (GERAN), Long Term Evolution (LTE), IEEE 802.15.1, 802.11ac, IEEE 802.16 (i.e., Worldwide Interoperability for Microwave Access (WiMAX)).

**[0025]** In an OFDMA system (e.g. 802.11ax), an associated HEW device 104 may operate on any 20MHz sub-channel of the BSS 50 (that can operate, for example, at 80MHz).

**[0026]** Embodiments pertain to wireless communications. Some embodiments relate to high-efficiency wireless communications including high-efficiency Wi-Fi/wireless local-area network (WLAN) and HEW communications. Some embodiments relate to wireless communications in accordance with one of the IEEE 802.11 standards including the High Efficiency WLAN Study Group (HEW SG) that is now IEEE 802.11ax Task Group.

**[0027]** In accordance with some IEEE 802.11ax (High-Efficiency Wi-Fi) embodiments, AP 104 may operate as a master station, which may be arranged to contend for a wireless medium (e.g., during a contention period) to receive exclusive control of the medium for a HEW control period (i.e., a transmission opportunity (TXOP)). The master station may transmit an HEW master-sync transmission at the beginning of the HEW control period. During the HEW control period, HEW stations may communicate with the master station in accordance with a non-contention based multiple access technique. This is unlike conventional Wi-Fi communications in which devices communicate in accordance with a contention-based communication technique, rather than a multiple access technique. During the HEW control period, the master station may communicate with HEW stations using one or more HEW frames. During the HEW control period, legacy stations refrain from communicating. In some embodiments, the master-sync transmission may be referred to as an HEW control and schedule transmission.

**[0028]** In some embodiments, the multiple-access technique used during the HEW control period may be a scheduled OFDMA technique, although this is not a requirement. In some embodiments, the multiple access technique may be a time-division multiple access (TDMA) technique or a frequency division multiple access (FDMA) technique. In some embodiments, the multiple access technique may be a space-division multiple access (SDMA) technique.

**[0029]** The master station may also communicate with legacy stations in accordance with legacy IEEE 802.11 communication techniques. In some embodiments, the master station may also be configurable to communicate with HEW stations outside the HEW control period in accordance with legacy IEEE 802.11 communication techniques, although this is not a requirement.

**[0030]** FIG. 2 illustrates a time sequence diagram 100 of an acknowledgement, in accordance with some example embodiments. Illustrated in FIG. 1 is a time sequence diagram 100, AP 104, STAs 108, SIG 120, DATA 122, and BACK 126. In example embodiments, the STAs 108 are HEW devices 102. The time sequence diagram 100 illustrates time 160 along the horizontal axis and frequency 150 along the vertical axis. The transmitter is indicated along the top.

- [0031]** The frequency 150 may be divided into four subchannels 1, 2, 3, 4. In example embodiments, each subchannel 1, 2, 3, 4 may have a bandwidth of 5 MHz. In example embodiments, each subchannel has a bandwidth, and the bandwidths may be different. For example, subchannels 1 and 2 may have a bandwidth of 5 MHz, subchannel 3 may have a bandwidth of 10 MHz, and subchannel 4 may have a bandwidth of 20 MHz. In example embodiments, the subchannels 1, 2, 3, 4 may be in accordance with a wireless standard. As illustrated, there is one AP 104 and four STAs 108. In example embodiments, there may be more or fewer STAs 108 and more or fewer APs 104.
- 10 **[0032]** In example embodiments, the STAs 108 and AP 104 may be using OFDMA to communicate. In example embodiments, the STAs 108 and AP 104 may be using uplink and downlink multiple-user multiple-input multiple-out (UL MU-MIMO) to communicate. In MU-MIMO, two or more spatial streams may be used that utilize the same frequency. In example  
15 embodiments, the STAs 108 and AP 104 may communicate according to a wireless communication standard. In example embodiments, the wireless standard may be 802.11, 802.11a, 802.11b, 802.11g, 802.11n, 802.11ac, 802.11ad, 802.11af, 802.11ah, 802.11ai, 802.11aj, 802.11aq, 802.11ax, Bluetooth, or another wireless standard.
- 20 **[0033]** In example embodiments, the STAs 108 are mobile devices. In example embodiments, the STAs 108 are wireless mobile devices. In example embodiments, the AP 104 is an AP. In example embodiments, the AP 104 is a mobile device. In example embodiments, the AP 104 is a wireless device. In example embodiments, the AP 104 is a STA 108.
- 25 **[0034]** In example embodiments, the SIG 120 is a signal that may include information regarding the data 122. In example embodiments, the SIG 120 may include information regarding the AP 104. In example embodiments, the SIG 120 may include information regarding an acknowledgement policy. In example embodiments, the SIG 120 may comprise a frame that complies with a  
30 wireless standard. In example embodiments, the SIG 120 comprises a control or management frame that complies with a wireless standard.
- [0035]** In example embodiments, the data 122 may be a signal that comprises a data frame that complies with a wireless standard. In example

embodiments, the BACK 126 may be a signal that comprises an acknowledgement frame in accordance with a wireless standard. In example embodiments, the BACK 126 may be a block acknowledgment in accordance with a wireless standard. In example embodiments, the data 122 includes an indication of an acknowledgement policy.

5 [0036] The time sequence diagram 100 begins at 162 with the AP 104 transmitting the SIG 120 to the STAs 108. In an example embodiment, the AP 104 may determine, based on the acknowledge policy being used, to include a bit in the SIG 120 that indicates to the STAs 108 to use an acknowledgement policy where the STAs 108 transmit an BACK 126 to the AP 104 without waiting for a request to transmit the BACK 126. In example embodiments, the AP 104 may transmit an indication to the STAs 108 of an acknowledgement policy in a previous frame.

10 [0037] The time sequence diagram 100 continues at 164 with the AP 104 transmitting data 122 to the STAs 108. For example, the AP 104 may transmit data 122.2 to STA2 108.2 on subchannel 3.

[0038] In an example embodiment, the AP 104 may determine not to transmit a schedule (SCH)/SIG after the data 122 based on the acknowledgement policy of the AP 104. In an example embodiment, the AP 104 may include an indication of an acknowledge policy in frames of the data 122.

20 [0039] The time sequence diagram 100 continues at 166 with the STAs 108 waiting to transmit ACKs 126. In some embodiments, the STAs 108 may wait a short interframe space (SIFS) 166 before transmitting the BACKs 126. In example embodiments, the STAs 108 may determine to not wait for a SCH and/or a SIG and/or an ACK request from the AP 104 based on an acknowledgement policy. In example embodiments, the STAs 108 may wait SIFs 166 before transmitting the ACKs 126 based on receiving an indication of an acknowledgement policy from the AP 104. In example embodiments, the STAs 108 may wait a period of time greater than the SIFS 166. In example  
25  
30 embodiments, the AP 104 may transmit to the STAs 108 a pre-determined amount of time the STAs 108 should wait before transmitting. In example embodiments, an indication of the acknowledgement policy may have been sent to the STAs 108 in an earlier frame such as a beacon or other management

frame, or in a control or data frame. For example, an indication of the acknowledgement policy may have been sent in the SIG 120 or DATA 122 frames.

**[0040]** The time sequence diagram 100 continues at 168 with the STAs 108 transmitting ACKs 126 to the AP 104. In example embodiments, the STAs 108 use the same subchannel on which they received the data 122 to transmit the ACK 126. For example, STA3 108.3 received data 122.3 on subchannel 2 and transmitted an ACK 126.3 to the AP 104 on subchannel 2. In example embodiments, the ACKs 126 are ACKs 126. In example embodiments, the STAs 108 are configured to send the BACKs 126 in response to the DATA 122 without receiving a SCH and/or a (SIG and/or an BACK request from the AP 104 based on an acknowledgement policy.

**[0041]** In example embodiments, the BACKs 126 are transmitted to the AP 104 in response to an implicit request from the AP 104 that is part of an acknowledgement policy. In example embodiments, the STAs 108 may transmit data (not illustrated) prior to or after transmitting the BACKs 126. In example embodiments, one of the SIG 120 or the DATA 122 includes a schedule, and the STAs transmit data according to the schedule. In example embodiments, the BACK 126 may be part of a data frame (not illustrated).

**[0042]** The STAs 108 transmitting BACKs 126 without receiving additional frames from the AP 104 may have the technical effect of saving time since transmitting a scheduling and/or SIG frame takes time. The scheduling and/or SIG frame may take 100 microseconds.

**[0043]** In some embodiments, the MU-MIMO may be used where one or more subchannels 1, 2, 3, 4 may be shared by more than one STA 108. For example, subchannel 4 may be shared by a MU-MIMO group such as STA1 108.1 and STA5 108.5 (not illustrated). In example embodiments, the acknowledgement policy may be based on a pre-determined rule. In example embodiments, the STA 108 may determine when to transmit a BACK 126 based on a spatial stream associated with the STA 108. In example embodiments, the STA 108 from the MU-MIMO group that the first spatial stream is intended for may be the first STA 108 to transmit the BACK 126 after the data 122 transmission is received.

[0044] FIG. 3 illustrates a time sequence diagram 200 of an acknowledgement, in accordance with some example embodiments. Illustrated in FIG. 3 is a time sequence diagram 200, AP 104, STAs 108, SIG 220, DATA 222, block acknowledgement request (BAR) 223, and BACK 226. The time sequence diagram illustrates time 260 along the horizontal axis and frequency 250 along the vertical axis. The transmitter is indicated along the top.

[0045] In example embodiments, the BAR 223 may be a signal that is a block acknowledgement request 223 according to a wireless standard. In example embodiments, the block acknowledgement (BACK) 226 may be a signal that is a block acknowledgement according to a wireless standard.

[0046] The time sequence diagram 200 begins at 262 with the AP 104 transmitting the SIG 220 to the STAs 108. The time sequence diagram 200 continues at 264 with the AP 104 transmitting data 222 to the STAs 108. For example, the AP 104 may transmit data 222.2 to STA2 108.2 on subchannel 3.

[0047] The time sequence diagram 200 continues at 266 with the AP 104 transmitting BAR 223 to the STAs 108. The BAR 223 may include an indication that the STAs 108 are to use an acknowledgement policy that indicates that the BACKs 226 are to be transmitted on the same subchannel 1, 2, 3, 4 in which the BAR 223 and/or DATA 222 was transmitted to the STAs 108. In example embodiments, the indication of the acknowledgement policy may have been sent to the STAs 108 in an earlier frame such as a beacon or other management frame, or in a control or data frame.

[0048] The time sequence diagram 200 may continue at 268 with the STAs 108 waiting to transmit BACKs 226. In example embodiments, the STAs 108 may wait a SIFS 268 before transmitting the BACKs 226. In example embodiments, the STAs 108 may determine to not wait for a SCH/SIG and wait SIFs 268 before transmitting the BACKs 226. In example embodiments, the STAs 108 may determine to not wait for a SCH/SIG and wait SIFs 268 before transmitting the BACKs 226 based on receiving an indication from the AP 104 that the SCH/SIG would not be sent. In example embodiments, the STAs 108 may wait a different period of time before transmitting the BACK 226.

[0049] The time sequence diagram 200 continues at 270 with the STAs 108 transmitting BACKs 226 to the AP 104. In some embodiments, the STAs

108 use the same subchannel on which they received the data 222 and/or BAR 223 to transmit the BACK 226. For example, STA3 108.3 received BAR 223.3 on subchannel 2 and transmitted a BACK 226.3 to the AP 104 on subchannel 2. In some embodiments, the STAs 108 are configured to send the BACKs 226 in response to the BAR 223 without receiving a SCH and/or a SIG based on receiving an indication to implement this acknowledgement policy from the AP 104.

**[0050]** In example embodiments, the MU-MIMO may be used where one or more subchannels 1, 2, 3, 4 may be shared by more than one STA 108. For example, subchannel 4 may be shared by a MU-MIMO group such as STA1 108.1 and STA5 108.5 (not illustrated). In example embodiments, the acknowledgement policy may be based on a pre-determined rule. In example embodiments, the STA 108 may determine when to transmit a BACK 226 based on a spatial stream associated with the STA 108. In example embodiments, the STA 108 from the MU-MIMO group that the first spatial stream is intended for may be the first STA 108 to transmit the BACK 226 after the DATA 222 transmission is received.

**[0051]** FIG. 4 illustrates a time sequence diagram 300 of an acknowledgement, in accordance with some example embodiments. Illustrated in FIG. 4 is a time sequence diagram 300, AP 104, STAs 108, SIG 320, DATA 322, multi-user block acknowledgement request (MU BAR) 323, and BACK 326. The time sequence diagram illustrates time 360 along the horizontal axis and frequency 350 along the vertical axis. The transmitter is indicated along the top.

**[0052]** In example embodiments, the MU BAR 323 may be a signal that is a multi-user BACK request according to a wireless standard. In example embodiments, the MU BAR 323 is a BACK request transmitted on subchannels 1, 2, 3, 4 to the STAs 108. In an example embodiment, the MU-BAR 323 may be a multicast/broadcast frame addressing multiple STAs 108. In example embodiments, the MU BAR 323 may include an indication that the STAs 108 are to use an acknowledgement policy that indicates on which subchannel 1, 2, 3,4 that the BACKs 326 are to be transmitted.

**[0053]** The time sequence diagram 300 begins at 362 with the AP 104 transmitting the SIG 320 to the STAs 108. The time sequence diagram 300 continues at 364 with the AP 104 transmitting data 322 to the STAs 108. For example, the AP 104 may transmit data 322.2 to STA2 108.2 on subchannel 3.

5 **[0054]** The time sequence diagram 300 continues at 366 with the AP 104 transmitting MU-BAR 323 to the STAs 108. In example embodiments, the MU BAR 323 may be transmitted on a band of the subchannels 1, 2, 3, 4 that polls two or more of the STAs 108 to transmit BACKs 326.

**[0055]** In example embodiments, the MU BAR 323 may include an  
10 indication that the STAs 108 are to use an acknowledgement policy that indicates that the BACKs 326 are to be transmitted on the same subchannel 1, 2, 3, 4 in which the DATA 622 was transmitted to the STAs 108. In example embodiments, the indication of the acknowledgement policy may have been sent to the STAs 108 in an earlier frame such as a management or control frame. In  
15 an example embodiment, MU-BAR 323 may include subchannel allocation for the uplink BACKs 326. In example embodiments, the MU-BAR 323 includes one or more of the following information: association identification (AID) of the STAs 108, subchannel for the STA 108 to use to transmit the BACK 326, and legacy BAR information that may be included in one or more wireless standards.

20 **[0056]** The time sequence diagram 300 continues at 368 with the STAs 108 waiting to transmit BACKs 326. In some embodiments, the STAs 108 may wait a SIFS 368 before transmitting the ACKs 326. In example embodiments, the STAs 108 may determine to not wait for a SCH/SIG and wait SIFs 366 before transmitting the ACKs 326 based on receiving an indication of an  
25 acknowledgement policy in the SIG 320.

**[0057]** The time sequence diagram 300 continues at 370 with the STAs 108 transmitting BACKs 326 to the AP 104. In example embodiments, the STAs 108 use the same subchannel on which they received the data 322 to transmit the BACK 326. For example, STA3 108.3 received data 322.3 on  
30 subchannel 2 and transmitted a BACK 326.3 to the AP 104 on subchannel 2. In example embodiments, the STAs 108 are configured to send the BACKs 326 in response to the MU BAR 323 without receiving a SCH and/or a SIG based on receiving an indication to implement this acknowledgement policy from the AP

104. In example embodiments, the STAs 108 are configured to transmit the BACKs 326 on an allocated subchannel 1, 2, 3, 4 based on a subchannel allocation in the MU-BAR 323.

**[0058]** In some embodiments, the MU-MIMO may be used where one or more subchannels 1, 2, 3, 4 may be shared by more than one STA 108. For example, subchannel 4 may be shared by a MU-MIMO group such as STA1 108.1 and STA5 108.5 (not illustrated). In example embodiments, the acknowledgement policy may be based on a pre-determined rule. In example embodiments, the STA 108 may determine when to transmit a BACK 326 based on a spatial stream associated with the STA 108. In example embodiments, the STA 108 from the MU-MIMO group for which the first spatial stream is intended may be the first STA 108 to transmit the BACK 326 after the DATA 322 transmission is received.

**[0059]** FIG. 5 illustrates a time sequence diagram 400 of an acknowledgement, in accordance with some example embodiments. Illustrated in FIG. 5 is a time sequence diagram 400, AP 104, STAs 108, SIG 420, DATA 422, MU BAR 423.1, MU BAR 423.2, and BACK 426. The time sequence diagram illustrates time 460 along the horizontal axis and frequency 450 along the vertical axis. The transmitter is indicated along the top. As illustrated, the AP 104 and two or more of the STAs 108 may be using MU-MIMO and OFDMA. As illustrated, the frequency 450 is illustrated twice (450.1 and 450.2), with 450.1 illustrating a first MU-MIMO group and 450.2 illustrating a second MU-MIMO group.

**[0060]** The time sequence diagram 400 begins at 462 with the AP 104 transmitting the SIG 420.1 and SIG 420.2 to the STAs 108. The time sequence diagram 400 continues at 464 with the AP 104 transmitting data 422 to the STAs 108. For example, the AP 104 may transmit data 422.2 to STA2 108.2 in a first spatial stream and STA6 108.6 on subchannel 3 in a second spatial stream.

**[0061]** The time sequence diagram 400 continues at 466 with the AP 104 MU-BAR 423.1 to the STAs 108. In an example embodiment, the MU BAR 423.1 may be transmitted on a band that polls two or more of the STAs 108 to transmit BACKs 426. For example, MU BAR 423.1 may poll STA1 108.1 through STA4 108.4 on subchannels 1, 2, 3, 4 in MU-MIMO group. The MU

BAR 423 may include an indication that the STAs 108 are to use an acknowledgement policy that indicates that the BACKs 426 are to be transmitted on the same subchannel 1, 2, 3, 4 in which the DATA 422 was transmitted to the STAs 108.

5 [0062] In example embodiments, the MU-BAR 423 may indicate which MU-MIMO group should respond. In example embodiments, the MU-BAR 423 may indicate that a MU-MIMO group should respond, and the STAs 108 may determine which group should respond based on a predetermined rule. In example embodiments, the indication of the acknowledgement policy may have  
10 been sent to the STAs 108 in an earlier frame such as a management or control frame. In example embodiments, the MU-BAR 423 may be a multicast/broadcast frame addressing multiple STAs 108. In example embodiments, MU-BAR 423 may include subchannel allocation for the uplink BACKs 426. The MU-BAR 423 may include one or more of the following  
15 information AID of the STAs 108: subchannel for the STA 108 to use to transmit the BACK 426 and legacy BAR information that may be included in one or more wireless standards.

[0063] The time sequence diagram 400 continues at 468 with the STAs 108 waiting to transmit BACKs 426. In example embodiments, the STAs 108  
20 may wait a short SIFS 468 before transmitting the BACKs 426. In example embodiments, the STAs 108 may determine to not wait for a SCH/SIG and wait SIFs 466 before transmitting the BACKs 426. In example embodiments, the STAs 108 may determine to not wait for a SCH/SIG and wait SIFs 466 before transmitting the BACKs 426 based on receiving an indication of an  
25 acknowledgement policy in the SIG 420.

[0064] The time sequence diagram 400 continues at 470 with the STAs 108 transmitting BACKs 426 to the AP 104. In an example embodiment, the STAs 108 use the same subchannel on which they received the data 422 to transmit the BACK 426. For example, STA3 108.3 received data 423.3 on  
30 subchannel 2 and transmitted a BACK 426.3 to the AP 104 on subchannel 2. In an example embodiment, the STAs 108 are configured to send the BACKs 426 in response to the MU-BAR 423 without receiving a SCH and/or a SIG based on receiving an indication to implement this acknowledgement policy from the AP

104. In an example embodiment, the STAs 108 are configured to transmit the BACKs 426 on subchannels 1, 2, 3, 4 based on a subchannel allocation in the MU-BAR 423.

[0065] The time sequence diagram 400 continues at 472 with the AP 104  
5 transmitting a second MU-BAR 423.2. In an example embodiment, the AP 104 transmits at least one MU-BAR 423 for each MU-MIMO group.

[0066] The time sequence diagram 400 continues at 474 with the STAs  
108 waiting to transmit BACKs 726. The time sequence diagram 400 continues  
at 476 with the STAs 108 transmitting BACKs 426 to the AP 104. In an  
10 example embodiment, the STAs 108 use the same subchannel on which they received the data 422 to transmit the BACK 426. For example, STA3 108.3 received data 422.3 on subchannel 2 and transmitted a BACK 426.3 to the AP 104 on subchannel 2. In an example embodiment, the STAs 108 are configured to send the BACKs 426 in response to the MU-BAR 423 without receiving a  
15 SCH and/or a SIG based on receiving an indication to implement this acknowledgement policy from the AP 104. In an example embodiment, the STAs 108 are configured to transmit the BACKs 426 on subchannels 1, 2, 3, 4 based on a subchannel allocation in the MU-BAR 423.

[0067] As illustrated, STA1 108.1 and STA5 108.5 are in different MU-  
20 MIMO groups. STA1 108.1 transmitted a BACK 426.1 to the AP 104 at 470 in response to MU-BAR 423.1 at 466. STA5 108.5 transmitted a BACK 426.5 to the AP 104 at 476 in response to the MU-BAR 423.2 at 472.

[0068] FIG. 6 illustrates a time sequence diagram 500 of an  
acknowledgement, in accordance with some example embodiments. Illustrated  
25 in FIG. 6 is a time sequence diagram 500, AP 104, STAs 108, SIG 520, DATA 522, MU BAR 523, and BACK 526. The time sequence diagram illustrates time 560 along the horizontal axis and frequency 550 along the vertical axis. The transmitter is indicated along the top. As illustrated, the AP 104 and two or more of the STAs 108 may be using MU-MIMO and OFDMA. As illustrated,  
30 the frequency 550 is illustrated twice (550.1 and 550.2), with 550.1 illustrating a first MU-MIMO group and 550.2 illustrating a second MU-MIMO group.

[0069] The time sequence diagram 500 begins at 562 with the AP 104 transmitting the SIG 520 to the STAs 108. In example embodiments, the AP 104 transmits separate SIGS 520 for the two illustrated MU-MIMO groups.

5 [0070] The time sequence diagram 500 continues at 564 with the AP 104 transmitting data 522 to the STAs 108. For example, the AP 104 may transmit data 522.2 to STA2 108.2 and data 522.6 to STA6 108.6 on subchannel 3. The data 522.2 and data 522.6 may be transmitted on different MU-MIMO groups.

[0071] The time sequence diagram 500 continues at 566 with the AP 104 transmitting multi-user block acknowledgement requests (MU-BAR) 523 to the  
10 STAs 108. In example embodiments, the MU BAR 523 may be transmitted on a band that polls two or more of the STAs 108 to transmit BACKs 526. In example embodiments, the MU BAR 523 may poll multiple MU-MIMO groups.

[0072] In example embodiments, the MU BAR 523 may include an indication that the STAs 108 are to use an acknowledgement policy that  
15 indicates that the BACKs 526 are to be transmitted on the same subchannels 1, 2, 3, 4 in which the DATA 522 was received by the STAs 108.

[0073] In example embodiments, the MU-BAR 523 may indicate which MU-MIMO group should respond. In an example embodiment, the MU-BAR 523 may indicate that a particular MU-MIMO group should respond. In  
20 example embodiments, the STAs 108 may determine which group should respond based on a predetermined rule. In example embodiments, the indication of the acknowledgement policy may have been sent to the STAs 108 in an earlier frame such as a management, data, or control frame.

[0074] In example embodiments, the MU-BAR 523 is a  
25 multicast/broadcast frame addressing multiple STAs 108. In example embodiments, MU-BAR 523 may include subchannel allocation for the uplink BACKs 526. In example embodiments, the MU-BAR 523 includes one or more of the following information AID of the STAs 108: subchannel for the STA 108 to use to transmit the BACK 526, order of the STAs 108 to transmit BACKs 826  
30 in the MU group that are following the MU-BAR 823, and legacy BAR information that may be included in one or more wireless standards. In example embodiments, the MU-BAR 523 is send once for each MU-MIMO group.

**[0075]** The time sequence diagram 500 may continue at 568 with the STAs 108 waiting to transmit BACKs 526. In some embodiments, the STAs 108 may wait a SIFS 568 before transmitting the BACKs 526. In example embodiments, the STAs 108 may determine to not wait for a SCH/SIG and wait  
5 SIFs 568 before transmitting the BACKs 526 based on receiving an indication from the AP 104 that the SCH/SIG would not be sent. In example embodiments, the STAs 108 may wait another length of time.

**[0076]** The time sequence diagram 500 continues at 570 with the STAs 108 transmitting BACKs 526 to the AP 104. In an example embodiment, the  
10 STAs 108 use the same subchannel on which they received the data 522 to transmit the BACK 526. For example, STA3 108.3 received BAR 523.3 on subchannel 2 and transmitted a BACK 526.3 to the AP 104 on subchannel 2. In an example embodiment, the STAs 108 are configured to send the BACKs 526 in response to the MU-BAR 523 without receiving a SCH and/or a SIG based on  
15 receiving an indication to implement this acknowledgement policy from the AP 104. In an example embodiment, the STAs 108 are configured to transmit the BACKs 526 on subchannels 1, 2, 3, 4 based on a subchannel allocation in the MU-BAR 523.

**[0077]** The time sequence diagram 500 may continue at 572 with the  
20 STAs 108 waiting to transmit BACKs 526. In some embodiments, the STAs 108 may wait a SIFS 572 before transmitting the BACKs 526. In an example embodiments, the STAs 108 may determine to not wait for a SCH/SIG and wait SIFs 572 before transmitting the BACKs 526 based on receiving an indication from the AP 104 that the SCH/SIG would not be sent. In example embodiments,  
25 the STAs 108 may wait another length of time.

**[0078]** The time sequence diagram 500 continues at 574 with the STAs 108 transmitting BACKs 526 to the AP 104. In an example embodiment, the STAs 108 use the same subchannel on which they received the data 522 to transmit the BACK 526. For example, STA3 108.3 received BAR 523.3 on  
30 subchannel 2 and transmitted a BACK 526.3 to the AP 104 on subchannel 2. In an example embodiment, the STAs 108 are configured to send the BACKs 526 in response to the MU-BAR 523 without receiving a SCH and/or a SIG based on receiving an indication to implement this acknowledgement policy from the AP

104. In an example embodiment, the STAs 108 are configured to transmit the BACKs 526 on subchannel 1, 2, 3, 4 based on a subchannel allocation in the MU-BAR 523.

[0079] As illustrated, STA1 108.1 and STA5 108.5 are in different MU-MIMO groups. STA1 108.1 transmitted a BACK 526.1 to the AP 104 at 570 in response to MU-BAR 523 at 566. STA5 108.5 transmitted a BACK 526.5 to the AP 104 at 574 in response to the MU-BAR 523 at 566.

[0080] In example embodiments, the technical effect is achieved of reducing the time to receive BACKs by requesting that BACK be sent in parallel. In example embodiments, the technical effect is achieved of reducing the time to receive BACK by not including a schedule subchannel allocation in a BAR.

[0081] FIG. 7 illustrates a frame 600 with a field 602 for acknowledgement in wireless networks, according to example embodiments. In example embodiments, the frame 600 is a signal that is a management, control, or data frame. In example embodiments, the frame 600 is a SIG frame, beacon frame, data frame, or MU BAR frame. In example embodiments, the field 602 may indicate an acknowledgement policy indicating how a STA 108 should acknowledge frames.

[0082] In example embodiments, the STA 108 is communicating in accordance with OFDMA and MU-MIMO. In example embodiments, the field 602 may indicate that the STA 108 should use a same subchannel or channel to acknowledge a frame as the frame was received on. In example embodiments, the STA 108 may be configured to use block acknowledgements. In example embodiments, the field 602 may be a single bit indicating that an OFDMA MU-MIMO acknowledgment policy should be used. The acknowledgment policy may be a block acknowledgment policy.

[0083] In example embodiments, the frame 600 is a frame transmitted prior to data frames, and the frame 600 includes an indication that data frames should be acknowledged using block acknowledgment on subchannels that were used to transmit the data frames.

[0084] In example embodiments, the field 602 may indicate an acknowledgement policy for groups in MU-MIMO. In example embodiments,

the field 602 indicates that a STA should block acknowledge based on the order of the MU-MIMO group. In example embodiments, the field 602 indicates that the STA should acknowledge frames in the order of their MU-MIMO group. In example embodiments, the field 602 indicates that the STA should acknowledge frames according to their MU-MIMO group and wait a SIFS before transmitting the block acknowledgement.

**[0085]** In example embodiment, the field 602 may indicate that the STA should wait a SIFS after receiving a block acknowledgement request to transmit a block acknowledgment.

10 **[0086]** In example embodiments, the field 602 indicates that the STA should use a predetermined rule for a subchannel to transmit a block acknowledgment on and/or a predetermined rule for an order of a MU-MIMO group to transmit a block acknowledgement.

**[0087]** In example embodiments, the frame 600 is a SIG frame and the field 602 indicates that the STAs should acknowledge data frames transmitted after the SIG frame without waiting for an acknowledgement request.

15 **[0088]** FIG. 8 illustrates a frame 700 with a field 702 for acknowledgement in wireless networks, according to example embodiments. In example embodiments, the frame 700 is a MU BAR signal and the field 702 indicates a subchannel allocation for a STA to use to transmit block acknowledgement of frames transmitted to the STA. In example embodiments, the frame 700 may be used for communications in OFDMA and MU-MIMO. In example embodiments, the frame 700 is a signal that is a block acknowledgement request for OFDMA and MU-MIMO. In example  
20 embodiments, the frame 700 is transmitted to poll multiple STAs at once to transmit multiple BACK in parallel back.

**[0089]** FIG. 9 illustrates a frame 800 with a field 802 for acknowledgement in wireless networks, according to example embodiments. The frame 800 may be a signal that is part of a management frame transmitted  
25 by the STA where the field 802 indicates one or more acknowledgement policies that are supported by the STA as disclosed herein.

**[0090]** FIG. 10 illustrates a HEW device, in accordance with some embodiments. HEW device 1000 may be an HEW compliant device that may be

arranged to communicate with one or more other HEW devices, such as HEW devices 104 (FIG. 1) or AP 104 (FIG. 1) as well as communicate with legacy devices 106 (FIG. 1). HEW devices 104 and legacy devices 106 may also be referred to as HEW STAs and legacy STAs, respectively. HEW device 1000  
5 may be suitable for operating as AP 104 (FIG. 1) or an HEW device 104 (FIG. 1). In accordance with embodiments, HEW device 1000 may include, among other things, physical layer (PHY) circuitry 1002 and medium-access control layer circuitry (MAC) 1004. PHY circuitry 1002 and MAC 1004 may be HEW  
10 compliant layers and may also be compliant with one or more legacy IEEE 802.11 standards. MAC 1004 may be arranged to configure physical layer convergence procedure protocol data unit PPDU and arranged to transmit and receive PPDU, among other things. HEW device 1000 may also include other hardware processing circuitry 1006 and memory 1008 configured to perform the various operations described herein.

15 **[0091]** In some embodiments, the MAC 1004 may be arranged to contend for a wireless medium during a contention period to receive control of the medium for the HEW control period and configure an HEW PPDU. The PHY circuitry 1002 may be arranged to transmit the HEW PPDU. The PHY circuitry 1002 may include circuitry for modulation/demodulation,  
20 upconversion/downconversion, filtering, amplification, and the like. In some embodiments, the hardware processing circuitry 1006 may include one or more processors. The hardware processing circuitry 1006 may be configured to perform functions based on instructions being stored in a random access memory (RAM) or read-only memory (ROM), or based on special purpose circuitry. In  
25 some embodiments, two or more antennas may be coupled to the PHY circuitry 1002 and arranged for sending and receiving signals including transmission of the HEW packets. The HEW device 1000 may include a transceiver (not shown) to transmit and receive data such as HEW PPDU. The memory 1008 may store information for configuring the other circuitry to perform operations for  
30 configuring and transmitting HEW packets and performing the various operations described herein including the reception of and transmission of SIGs 120, 220, 320, 420, and 520; DATA 122,222, 322, 422, and 522; MU BAR 323, 423, and 523; BAR 223; BACK 226, 326, 426, and 526; frames 600 and 700;

and, ACK 126. In example embodiments, the circuitry of one or more of the antenna, transceiver, PHY circuitry 1002, MAC 1004, and processing 1006 may be configured to perform operations for configuring and transmitting HEW packets and performing the various operations described herein including the  
5 reception of and transmission of SIGs 120, 220, 320, 420, and 520; DATA 122,222, 322, 422, and 522; MU BAR 323, 423, and 523; BAR 223; BACK 226, 326, 426, and 526; frames 600 and 700; and, ACK 126.

**[0092]** In some embodiments, the HEW device 1000 may be configured to communicate using OFDM communication signals over a multicarrier  
10 communication channel. In some embodiments, HEW device 1000 may be configured to communicate in accordance with one or more specific communication standards, such as the IEEE standards including IEEE 802.11-2012, 802.11n-2009, 802.11ac-2013, 802.11ax, standards and/or proposed specifications for WLANs, although the scope of the example embodiments is  
15 not limited in this respect as they may also be suitable to transmit and/or receive communications in accordance with other techniques and standards.

**[0093]** In some embodiments, an HEW device 1000 may be part of a portable wireless communication device, such as a PDA) a laptop or portable computer with wireless communication capability, a web tablet, a wireless  
20 telephone, a smartphone, a wireless headset, a pager, an instant messaging device, a digital camera, an AP, a television, a medical device (e.g., a heart rate monitor, a blood pressure monitor, etc.), a base station, a transmit/receive device for a wireless standard such as 802.11 or 802.16, or other device that may receive and/or transmit information wirelessly. In some embodiments, the  
25 mobile device may include one or more of a keyboard, a display, a non-volatile memory port, multiple antennas, a graphics processor, an application processor, speakers, and other mobile device elements. The display may be an LCD screen including a touch screen.

**[0094]** The antennas may comprise one or more directional or  
30 omnidirectional antennas, including, for example, dipole antennas, monopole antennas, patch antennas, loop antennas, microstrip antennas or other types of antennas suitable for transmission of RF signals. In some MIMO embodiments,

the antennas may be effectively separated to take advantage of spatial diversity and the different channel characteristics that may result.

**[0095]** Although the device 1000 is illustrated as having several separate functional elements, one or more of the functional elements may be combined  
5 and may be implemented by combinations of software-configured elements, such as processing elements including DSPs, and/or other hardware elements. For example, some elements may comprise one or more microprocessors, DSPs, FPGAs, ASICs, transmitters, receivers, transceivers, RFICs, and combinations of various hardware and logic circuitry for performing at least the functions  
10 described herein. In some embodiments, the functional elements may refer to one or more processes operating on one or more processing elements.

**[0096]** Embodiments may be implemented in one or a combination of hardware, firmware and software. Embodiments may also be implemented as instructions stored on a computer-readable storage device, which may be read  
15 and executed by at least one processor to perform the operations described herein. A computer-readable storage device may include any non-transitory mechanism for storing information in a form readable by a machine (e.g., a computer). For example, a computer-readable storage device may include ROM, RAM, magnetic disk storage media, optical storage media, flash-memory  
20 devices, and other storage devices and media. Some embodiments may include one or more processors and may be configured with instructions stored on a computer-readable storage device.

**[0097]** The following examples pertain to further embodiments.  
Example 1 is a station (STA) including hardware processing circuitry configured  
25 to: receive data frames on a subchannel from an access point (AP) in accordance with down link (DL) multi-user multiple input and multiple output (MU-MIMO) and orthogonal frequency division multiple access (OFDMA). The hardware circuitry may be configured to: transmit a block acknowledgement of the data frames in accordance with uplink (UL) MU-MIMO and OFDMA, in response to  
30 the data frames.

**[0098]** In Example 2, the subject matter of Example 1 can optionally include: where the hardware processing circuitry is further configured to: transmit the block acknowledgement of the data frames on the subchannel.

- [0099] In Example 3, the subject matter of Examples 1 and 2 can optionally include: where the hardware processing circuitry is further configured to: transmit the block acknowledgement of the data frames when a block acknowledgement request has not been received by the STA.
- 5 [00100] In Example 4, the subject matter of Examples 1 through 3 can optionally include: where the hardware processing circuitry is further configured to: receive an indication of an acknowledgment policy from the AP.
- [00101] In Example 5, the subject matter of Examples 1 through 4 can optionally include: where the hardware processing circuitry is further configured  
10 to wait a short interframe space (SIFS) time before the transmit.
- [00102] In Example 6, the subject matter of Examples 1 through 5 can optionally include: where the hardware processing circuitry is further configured to wait a predetermined time before the transmit, where the predetermined time is longer than a short interframe space (SIFS) time.
- 15 [00103] In Example 7, the subject matter of Examples 1 through 6 can optionally include: where the hardware processing circuitry is further configured to transmit the block acknowledgement at a time based on a MU-MIMO group identification of the wireless device.
- [00104] In Example 8, the subject matter of Examples 1 through 7 can  
20 optionally include: where the hardware processing circuitry is further configured to: transmit second data frames in accordance with UL MU-MIMO and OFDMA, wherein the second data frames comprises the block acknowledgement of the data frames, in response to the data frames.
- [00105] In Example 9, the subject matter of Examples 1 through 8 can  
25 optionally include: where the hardware processing circuitry is further configured to: transmit second data frames on the subchannel, and transmit the block acknowledgement of the data frames on the subchannel in accordance with UL MU-MIMO and OFDMA, in response to the data frames.
- [00106] In Example 10, the subject matter of Examples 1 through 9 can  
30 optionally include: where the hardware processing circuitry is further configured to: receive a signal frame from the AP prior to the data frames.
- [00107] In Example 11, the subject matter of Examples 1 through 10 can optionally include: where the data frames or the signal frame comprise an

indication of a schedule; and where the second data frames are transmitted according to the schedule.

**[00108]** In Example 12, the subject matter of Examples 1 through 11 can optionally include: where the data frames or the signal frame comprise an indication to transmit the block acknowledgement of the data on the subchannel.

**[00109]** In Example 13, the subject matter of Examples 1 through 8 can optionally include: memory and a transceiver coupled to the processing circuitry.

**[00110]** In Example 14, the subject matter of Example 13 can optionally include: one or more antennas coupled to the transceiver.

10 **[00111]** Example 15 is a method on a station (STA). The method including receiving data frames on a subchannel from an access point (AP) using multi-user multiple-input multiple-output (MU MIMO). The method may further include transmitting a block acknowledgement of the data frames, wherein the block acknowledgement is transmitted without receiving a block acknowledgement request, in response to receiving the data frames.

15 **[00112]** In Example 16, the subject matter of Example 15 can optionally include: transmitting the block acknowledgement of the data frames on the subchannel.

**[00113]** In Example 17, the subject matter of Examples 15 and 16 can optionally include: waiting a short interframe space (SIFS) time before transmitting.

**[00114]** In Example 18 is an access point (AP). The AP may include hardware processing circuitry configured to: transmit first data frames to a first station (STA) on a first subchannel and concurrently transmit second data frames to a second STA on a second subchannel in accordance with down link (DL) multi-user multiple input and multiple output (MU-MIMO) and orthogonal frequency division multiple access (OFDMA). The hardware processing circuitry may be further configured to receive a first block acknowledgement from the first STA and concurrently receive a second block acknowledgement from the second STA in accordance with uplink (UL) MU-MIMO and OFDMA, where the first block acknowledgement is received on one of the first and second subchannels, and the second block acknowledgement is received on the other of the first and second subchannels.

[00115] In Example 19, the subject matter of Example 18 can optionally include: where the first subchannel and the second subchannel have a first bandwidth and a second bandwidth, respectively; and where the first bandwidth and the second bandwidth are each one of the following group: 1 MHz, 1.25  
5 MHz, 2.5 MHz, 5MHz, 10MHz, 20MHz, 40Mhz, 80MHz, and 160 MHz; and where the first subchannel and the second subchannel are different portions of a radio spectrum.

[00116] In Example 20, the subject matter of Examples 18 and 19 can optionally include where the hardware processing circuitry is further configured  
10 to: transmit the first transmission to the first STA on the first subchannel and a third transmission to a third STA on the first subchannel.

[00117] In Example 21, the subject matter of Examples 18 through 20 may option include where the hardware processing circuitry is further configured to: transmit a multi-user (MU) block acknowledgement request (BAR).

15 [00118] In Example 22, the subject matter of Example 21 may optionally include where the MU-BAR comprises a scheduling subchannel allocation.

[00119] In Example 23, the subject matter of Example 21 may optionally include where the hardware processing circuitry is further configured to: receive  
20 a third block acknowledgement from the third STA after the first block acknowledgement from the first STA is received, wherein the third subchannel and the first subchannel occupy the same portion of the radio spectrum.

[00120] Example 24 is a non-transitory computer-readable storage medium that stores instructions for execution by one or more processors to perform operations for block acknowledgement. The instructions configure the  
25 one or more processors to: receive data frames on a subchannel from an access point (AP) in accordance with down link (DL) multi-user multiple input and multiple output (MU-MIMO) and orthogonal frequency division multiple access (OFDMA); and transmit a block acknowledgement of the data frames on a subchannel in accordance with uplink (UL) MU-MIMO and OFDMA, in  
30 response to the data frames.

[00121] In Example 25, the subject matter of Example 24 may optionally include where the instructions further configure the one or more processors to:

transmit the block acknowledgement when a block acknowledgement request has not been received.

**[00122]** The Abstract is provided to comply with 37 C.F.R. Section 1.72(b) requiring an abstract that will allow the reader to ascertain the nature and gist of the technical disclosure. It is submitted with the understanding that it will not be used to limit or interpret the scope or meaning of the claims. The following claims are hereby incorporated into the detailed description, with each claim standing on its own as a separate embodiment.

## CLAIMS

What is claimed is:

- 5           1.       A station (STA), the STA comprising hardware processing  
circuitry configured to:  
                  receive data frames on a subchannel from an access point (AP) in  
accordance with down link (DL) multi-user multiple input and multiple output  
(MU-MIMO) and orthogonal frequency division multiple access (OFDMA); and  
10                in response to the data frames, transmit a block acknowledgement  
of the data frames in accordance with uplink (UL) MU-MIMO and OFDMA.
2.       The STA according to claim 1, wherein the hardware processing  
circuitry is further configured to:  
15                transmit the block acknowledgement of the data frames on the  
subchannel.
3.       The STA according to claim 1, wherein the hardware processing  
circuitry is further configured to:  
20                transmit the block acknowledgement of the data frames when a  
block acknowledgement request has not been received by the STA.
4.       The STA according to claim 1, wherein the hardware processing  
circuitry is further configured to:  
25                receive an indication of an acknowledgment policy from the AP.
5.       The STA according to claim 1, wherein the hardware processing  
circuitry is further configured to wait a short interframe space (SIFS) time before  
the transmit.  
30
6.       The STA according to claim 1, wherein the hardware processing  
circuitry is further configured to wait a predetermined time before the transmit,

wherein the predetermined time is longer than a short interframe space (SIFS) time.

7. The STA according to claim 1, wherein the hardware processing  
5 circuitry is further configured to transmit the block acknowledgement at a time based on a MU-MIMO group identification of the wireless device.

8. The STA according to claim 1, wherein the hardware processing  
circuitry is further configured to:  
10 in response to the data frames, transmit second data frames in accordance with UL MU-MIMO and OFDMA, wherein the second data frames comprises the block acknowledgement of the data frames.

9. The STA according to claim 1, wherein the hardware processing  
15 circuitry is further configured to:  
in response to the data frames, transmit second data frames on the subchannel, and transmit the block acknowledgement of the data frames on the subchannel in accordance with UL MU-MIMO and OFDMA.

20 10. The STA according to claim 1, wherein the hardware processing circuitry is further configured to:  
receive a signal frame from the AP prior to the data frames.

11. The STA according to claim 10, wherein the data frames or the  
25 signal frame comprise an indication of a schedule; and  
wherein the second data frames are transmitted according to the schedule.

12. The STA according to claim 10, wherein the data frames or the  
signal frame comprise an indication to transmit the block acknowledgement of  
30 the data on the subchannel.

13. The STA according to claim 1, further comprising memory and a transceiver coupled to the processing circuitry.

14. The STA according to claim 13, further comprising one or more antennas coupled to the transceiver.
- 5 15. A method on a station (STA), the method comprising:  
receiving data frames on a subchannel from an access point (AP)  
using multi-user multiple-input multiple-output (MU MIMO);  
in response to receiving the data frames, transmitting a block  
acknowledgement of the data frames, wherein the block acknowledgement is  
10 transmitted without receiving a block acknowledgement request.
16. The method of claim 15, further comprising:  
transmitting the block acknowledgement of the data frames on the  
subchannel.  
15
17. The method of claim 15, further comprising:  
waiting a short interframe space (SIFS) time before transmitting.
18. An access point (AP), the AP comprising:  
20 comprising memory and a transceiver;  
one or more antennas coupled to the transceiver; and  
hardware processing circuitry coupled to the memory and the  
transceiver and configured to:  
transmit first data frames to a first station (STA) on a first  
25 subchannel and concurrently transmit second data frames to a second STA on a  
second subchannel in accordance with down link (DL) multi-user multiple input  
and multiple output (MU-MIMO) and orthogonal frequency division multiple  
access (OFDMA);  
receive a first block acknowledgement from the first STA and  
30 concurrently receive a second block acknowledgement from the second STA in  
accordance with uplink (UL) MU-MIMO and OFDMA; and

wherein the first block acknowledgement is received on one of the first and second subchannels, and the second block acknowledgement is received on the other of the first and second subchannels.

- 5           19.    The AP of claim 18, wherein the first subchannel and the second subchannel have a first bandwidth and a second bandwidth, respectively; and  
              wherein the first bandwidth and the second bandwidth are each one of the following group: 1 MHz, 1.25 MHz, 2.5 MHz, 5MHz, 10MHz, 20MHz, 40Mhz, 80MHz, and 160 MHz; and  
10           wherein the first subchannel and the second subchannel are different portions of a radio spectrum.

20.    The AP of claim 18, wherein the hardware processing circuitry is further configured to:  
15           transmit the first transmission to the first STA on the first subchannel and a third transmission to a third STA on the first subchannel.

21.    The AP of claim 18, wherein the hardware processing circuitry is further configured to:  
20           transmit a multi-user (MU) block acknowledgement request (BAR).

22.    The AP of claim 21, wherein the MU-BAR comprises a scheduling subchannel allocation.  
25

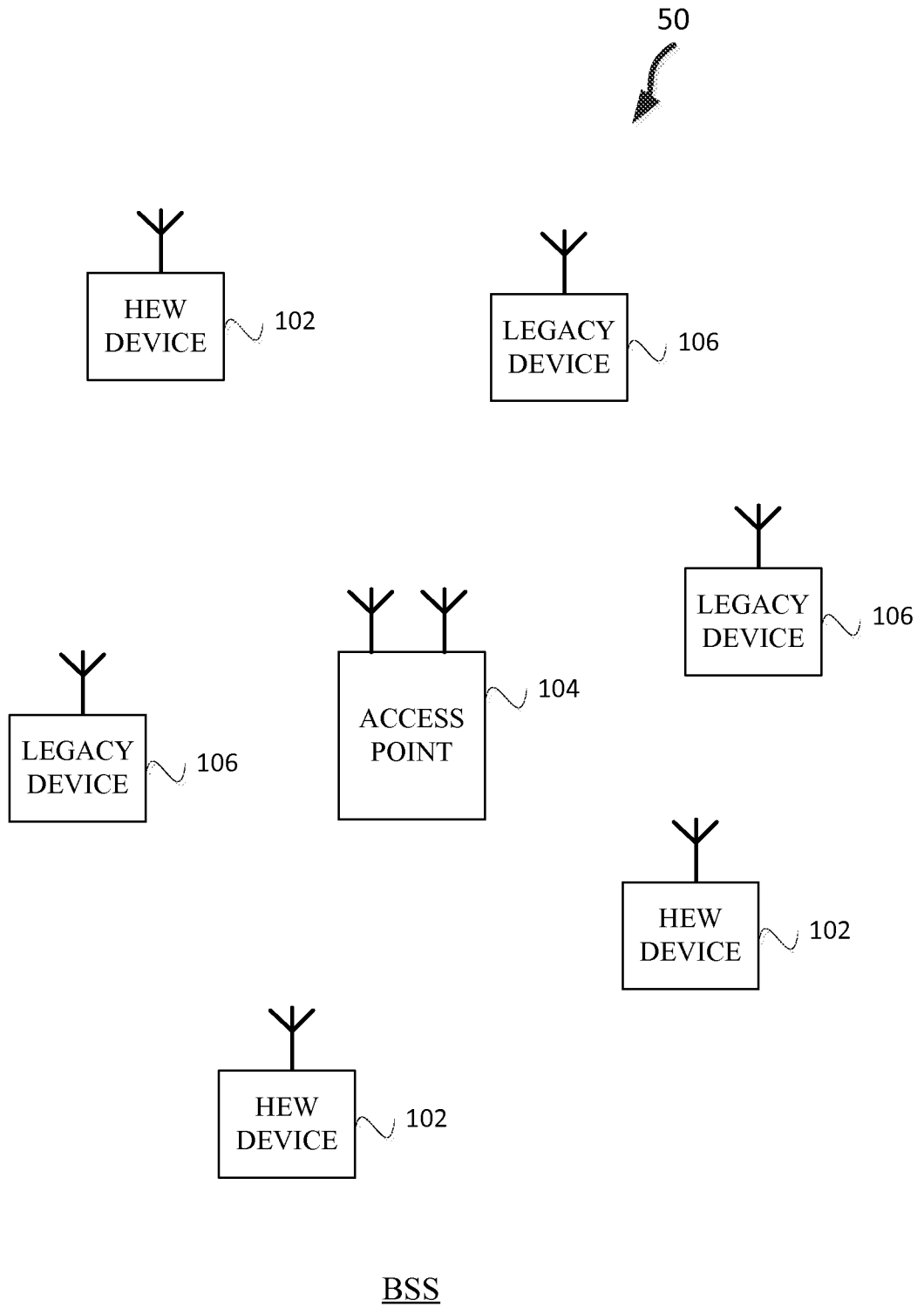
23.    The AP of claim 21, wherein the hardware processing circuitry is further configured to:  
              receive a third block acknowledgement from the third STA after the first block acknowledgement from the first STA is received, wherein the  
30           third subchannel and the first subchannel occupy the same portion of the radio spectrum.

24. A non-transitory computer-readable storage medium that stores instructions for execution by one or more processors to perform operations for block acknowledgement, the instructions to configure the one or more processors to:

- 5 receive data frames on a subchannel from an access point (AP) in accordance with down link (DL) multi-user multiple input and multiple output (MU-MIMO) and orthogonal frequency division multiple access (OFDMA); and  
in response to the data frames, transmit a block acknowledgement of the data frames on a subchannel in accordance with uplink (UL) MU-MIMO and  
10 OFDMA.

25. The non-transitory computer-readable storage medium of claim 24, wherein the instructions further configure the one or more processors to:

- transmit the block acknowledgement when a block acknowledgement  
15 request has not been received.



*FIG. 1*

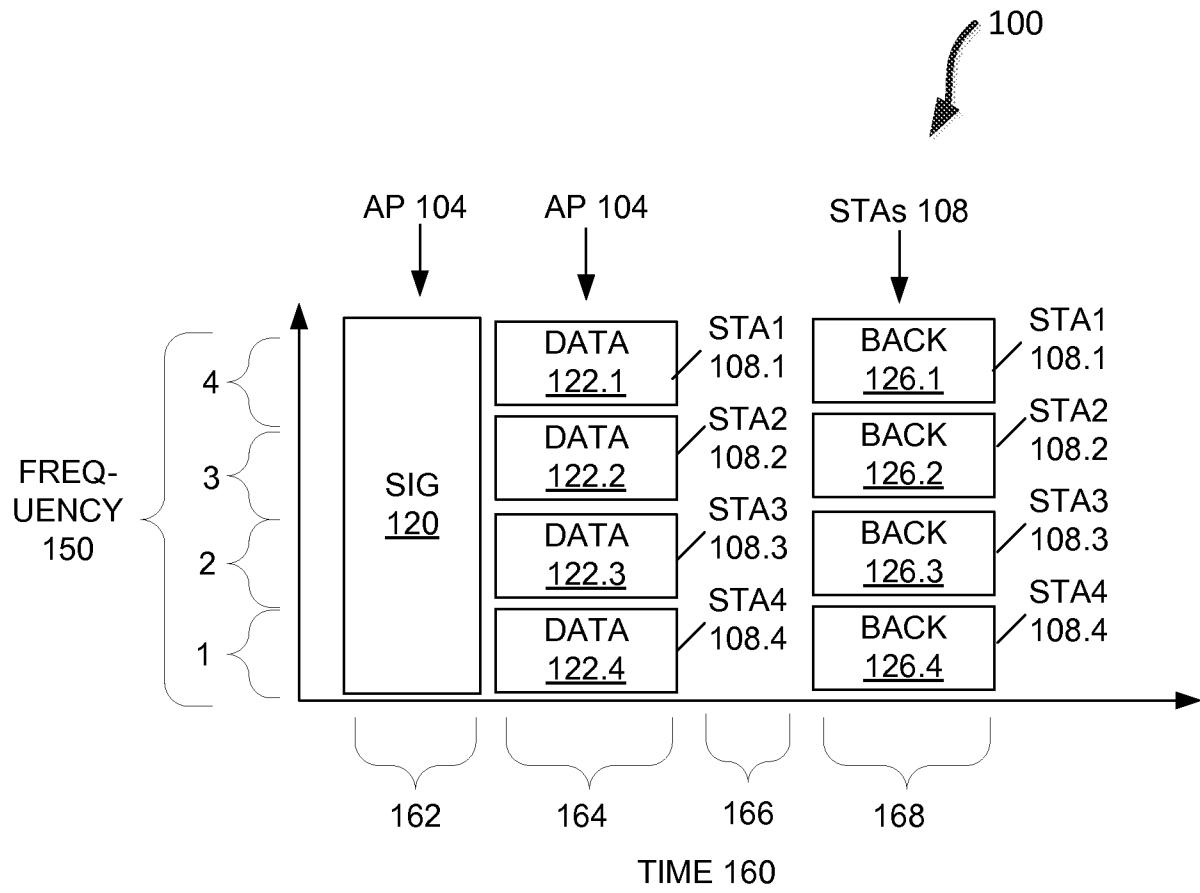


FIG. 2

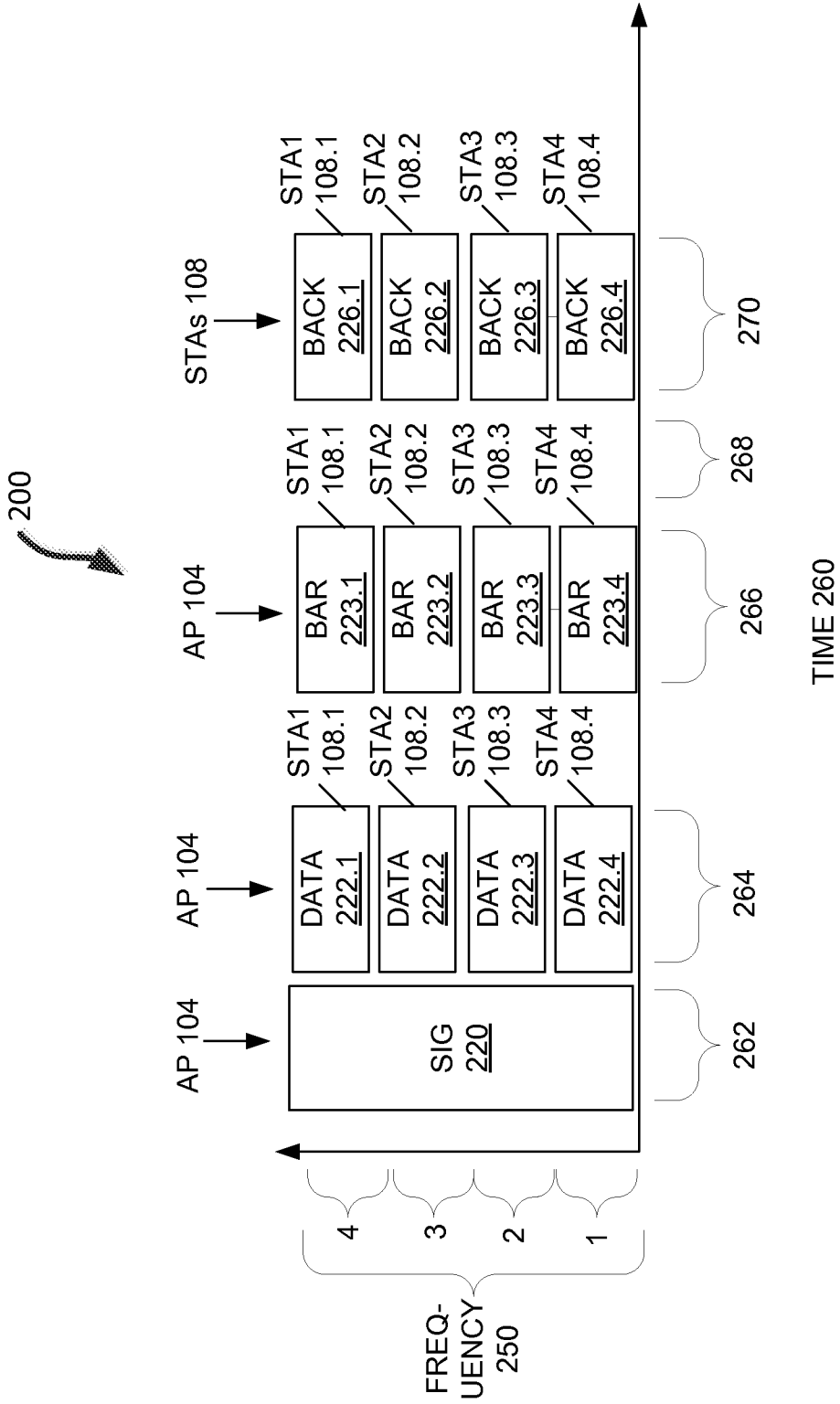


FIG. 3

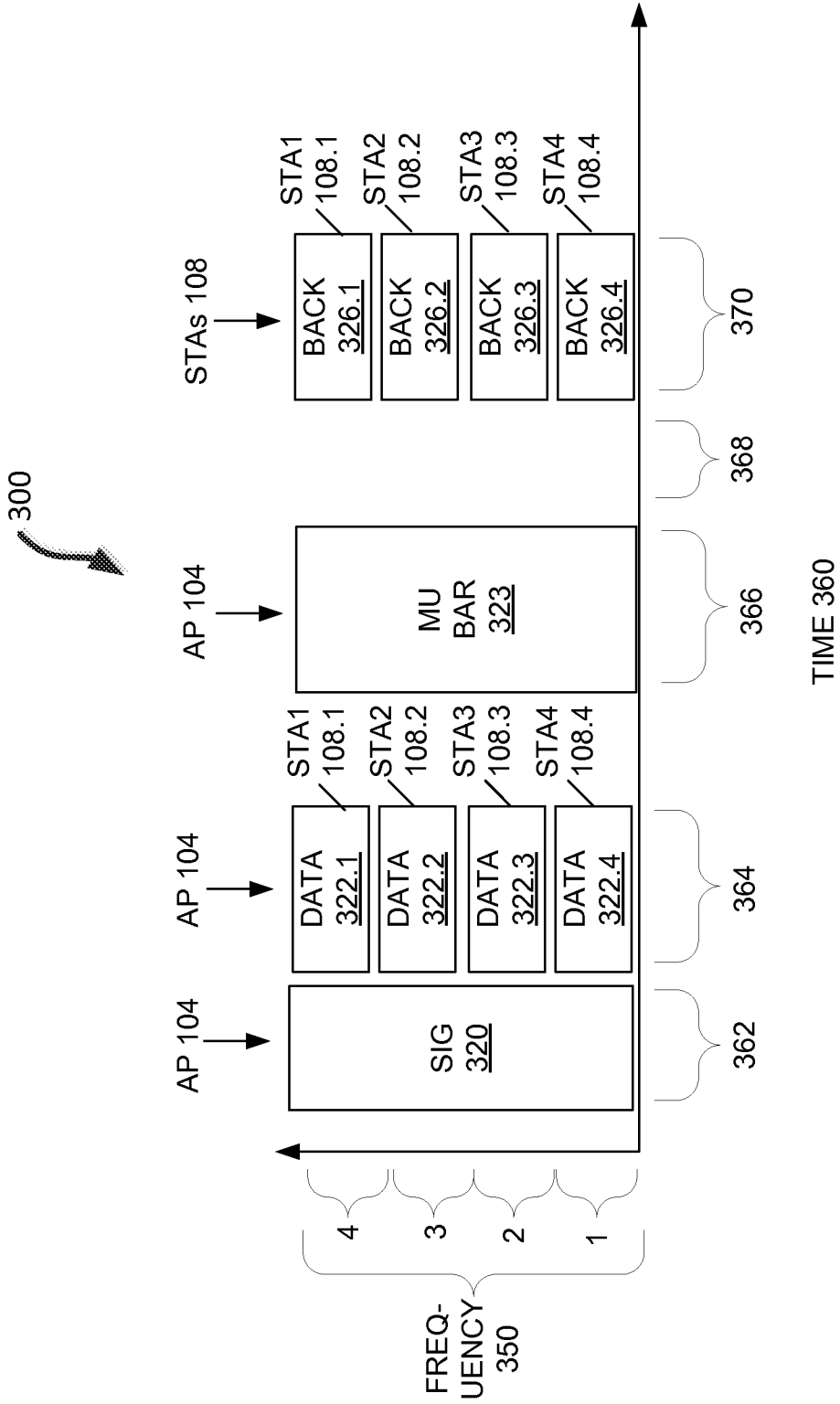
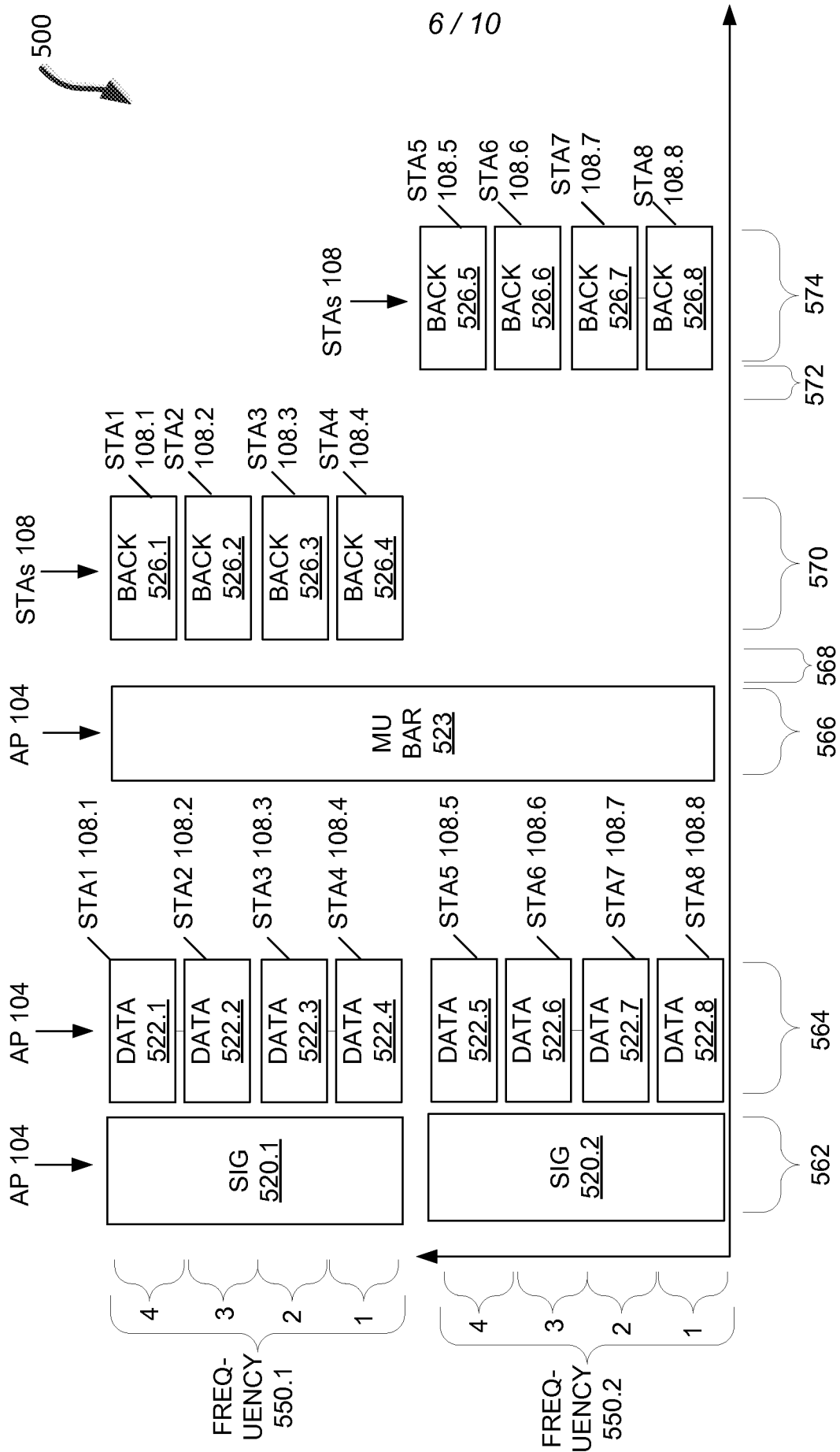


FIG. 4

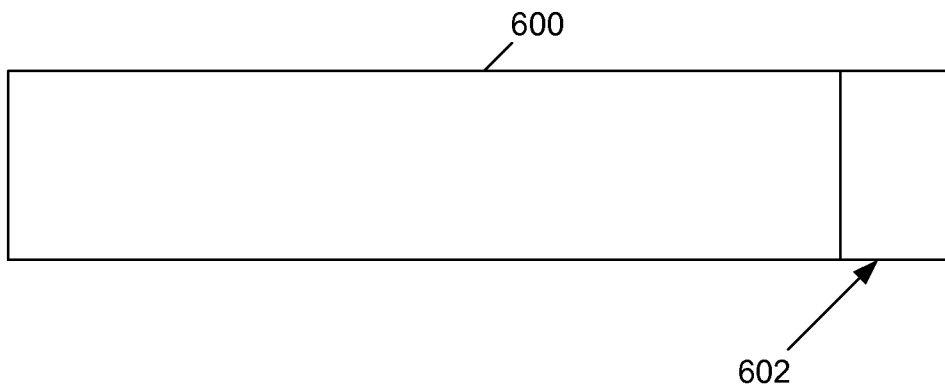




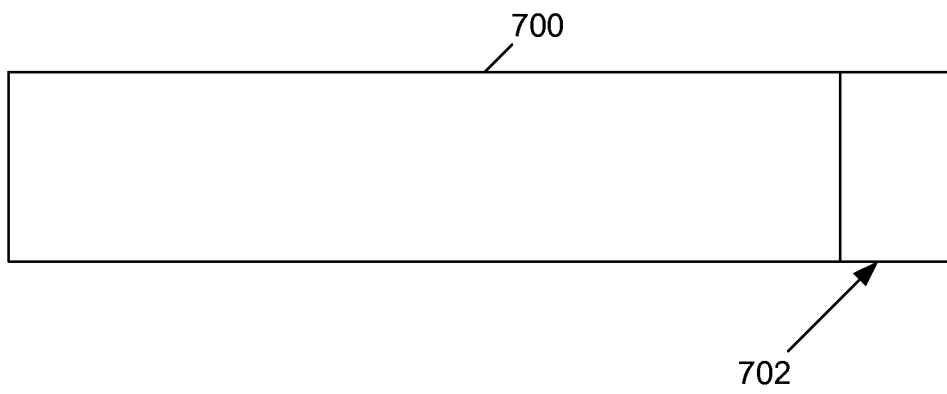
TIME 560

FIG. 6

7 / 10

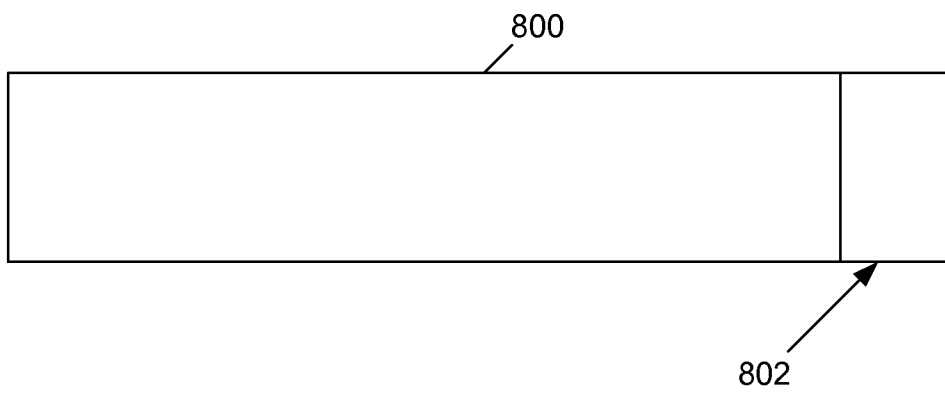


*FIG. 7*



*FIG. 8*

9 / 10



*FIG. 9*

10 / 10

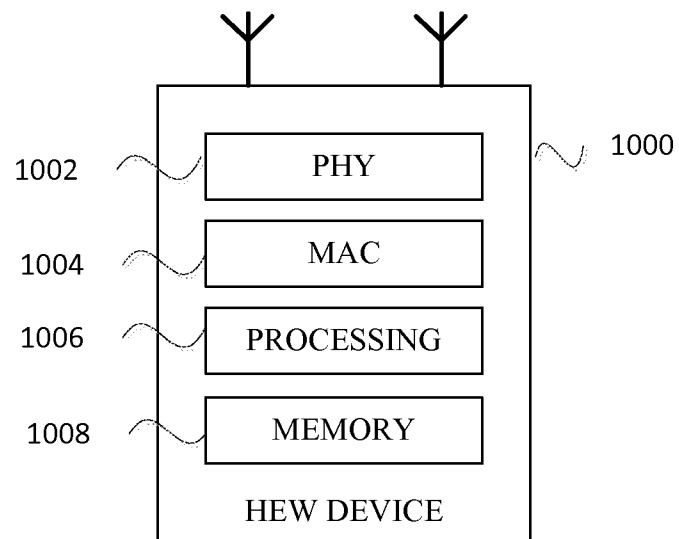


FIG. 10

## INTERNATIONAL SEARCH REPORT

International application No.  
**PCT/US2015/024889****A. CLASSIFICATION OF SUBJECT MATTER****H04L 27/26(2006.01)i, H04B 7/04(2006.01)i**

According to International Patent Classification (IPC) or to both national classification and IPC

**B. FIELDS SEARCHED**

Minimum documentation searched (classification system followed by classification symbols)

H04L 27/26; H04W 4/06; H04L 5/00; H04W 24/00; H04B 7/06; H04W 72/04; H04W 84/02; H04B 7/04

Documentation searched other than minimum documentation to the extent that such documents are included in the fields searched

Korean utility models and applications for utility models

Japanese utility models and applications for utility models

Electronic data base consulted during the international search (name of data base and, where practicable, search terms used)

eKOMPASS(KIPO internal) &amp; keywords: block acknowledgement, MU-MIMO, OFDMA, subchannel

**C. DOCUMENTS CONSIDERED TO BE RELEVANT**

Category*	Citation of document, with indication, where appropriate, of the relevant passages	Relevant to claim No.
X	US 2013-0286925 A1 (BROADCOM CORPORATION) 31 October 2013 See paragraphs [0077]-[0262]; and figures 13A-35.	1, 8-14, 24
Y		2-7, 15-23, 25
Y	US 2013-0286959 A1 (INTERDIGITAL PATENT HOLDINGS, INC.) 31 October 2013 See paragraphs [0096]-[0312]; and figures 28-38.	2-7, 15-23, 25
A	US 2014-0016607 A1 (CISCO TECHNOLOGY, INC.) 16 January 2014 See paragraphs [0025]-[0056]; and figures 4-8.	1-25
A	US 2011-0261708 A1 (SUDHEER A. GRANDHI) 27 October 2011 See paragraphs [0071]-[0142]; and figures 2-9.	1-25
A	WO 2014-066785 A1 (INTERDIGITAL PATENT HOLDINGS, INC.) 01 May 2014 See paragraphs [0145]-[0182]; and figures 13-23.	1-25

 Further documents are listed in the continuation of Box C. See patent family annex.

\* Special categories of cited documents:

"A" document defining the general state of the art which is not considered to be of particular relevance

"E" earlier application or patent but published on or after the international filing date

"L" document which may throw doubts on priority claim(s) or which is cited to establish the publication date of another citation or other special reason (as specified)

"O" document referring to an oral disclosure, use, exhibition or other means

"P" document published prior to the international filing date but later than the priority date claimed

"T" later document published after the international filing date or priority date and not in conflict with the application but cited to understand the principle or theory underlying the invention

"X" document of particular relevance; the claimed invention cannot be considered novel or cannot be considered to involve an inventive step when the document is taken alone

"Y" document of particular relevance; the claimed invention cannot be considered to involve an inventive step when the document is combined with one or more other such documents, such combination being obvious to a person skilled in the art

"&amp;" document member of the same patent family

Date of the actual completion of the international search

26 June 2015 (26.06.2015)

Date of mailing of the international search report

**29 June 2015 (29.06.2015)**

Name and mailing address of the ISA/KR

International Application Division  
Korean Intellectual Property Office  
189 Cheongsu-ro, Seo-gu, Daejeon Metropolitan City, 302-701,  
Republic of Korea

Facsimile No. +82-42-472-7140

Authorized officer

KIM, Do Weon

Telephone No. +82-42-481-5560



**INTERNATIONAL SEARCH REPORT**

Information on patent family members

International application No.

**PCT/US2015/024889**

Patent document cited in search report	Publication date	Patent family member(s)	Publication date
US 2013-0286925 A1	31/10/2013	US 2010-0309834 A1 US 8526351 B2 US 9007983 B2	09/12/2010 03/09/2013 14/04/2015
US 2013-0286959 A1	31/10/2013	CN 104321998 A EP 2845342 A1 KR 10-2015-0013640 A TW 201352039 A WO 2013-165582 A1	28/01/2015 11/03/2015 05/02/2015 16/12/2013 07/11/2013
US 2014-0016607 A1	16/01/2014	CN 102792628 A EP 2545672 A1 EP 2545672 B1 US 2011-0222486 A1 US 8559323 B2 WO 2011-112279 A1	21/11/2012 16/01/2013 09/07/2014 15/09/2011 15/10/2013 15/09/2011
US 2011-0261708 A1	27/10/2011	AU 2011-240640 A1 CN 102845101 A DK 2559288 T3 EP 2559288 A1 EP 2559288 B1 EP 2797357 A2 EP 2797357 A3 ES 2513541 T3 JP 2013-526153 A JP 2014-168303 A KR 10-2013-0053408 A MX 2012011873 A TW 201204160 A WO 2011-130344 A1	08/11/2012 26/12/2012 15/09/2014 20/02/2013 23/07/2014 29/10/2014 21/01/2015 27/10/2014 20/06/2013 11/09/2014 23/05/2013 07/02/2013 16/01/2012 20/10/2011
WO 2014-066785 A1	01/05/2014	None	