



May 29, 1923.

1,456,665

A. E. AUGUSTINE

ELEVATOR CONTROL MECHANISM FOR ENVELOPE MAKING MACHINES

Filed Aug. 5, 1919

3 Sheets-Sheet 2

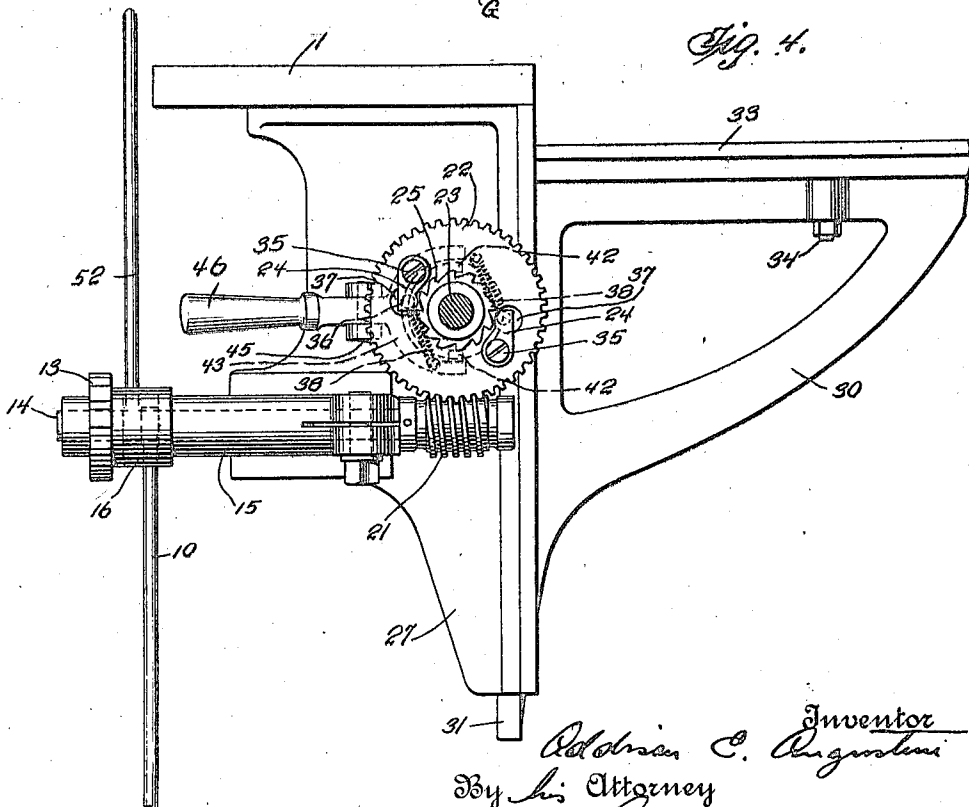
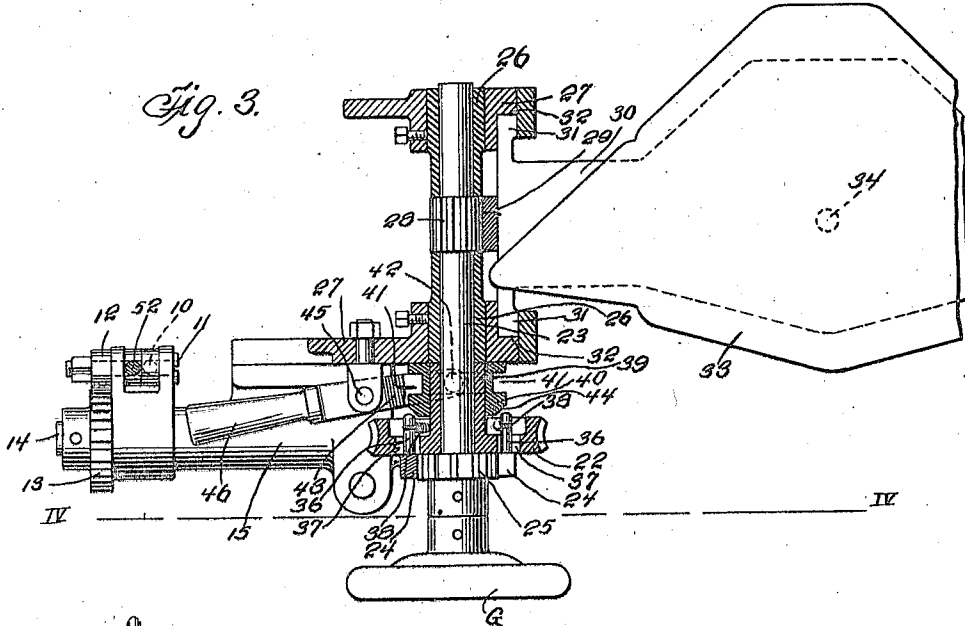

Inventor  
A. E. Augustine  
By his Attorney  
A. Sanford Hand

May 29, 1923.

1,456,665

A. E. AUGUSTINE

ELEVATOR CONTROL MECHANISM FOR ENVELOPE MAKING MACHINES

Filed Aug. 5, 1919

3 Sheets-Sheet 3

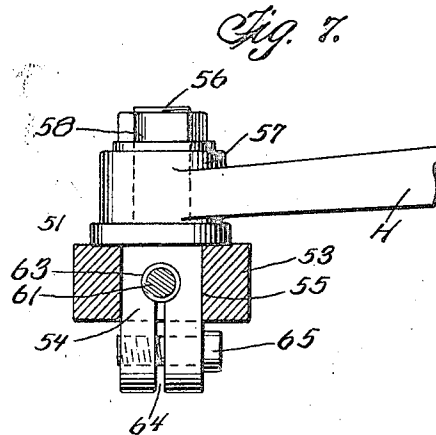
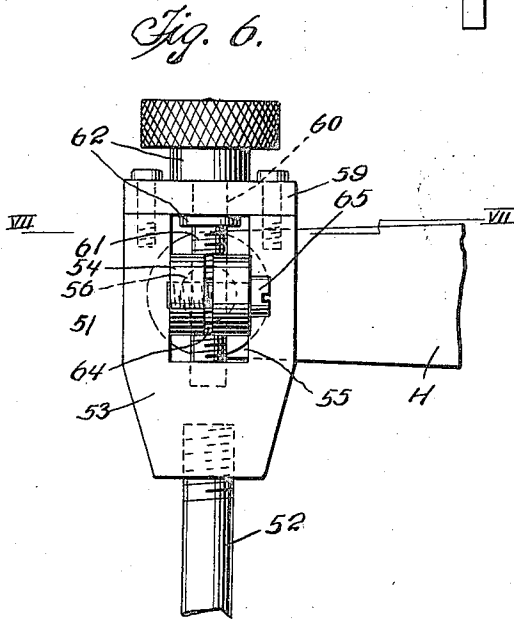
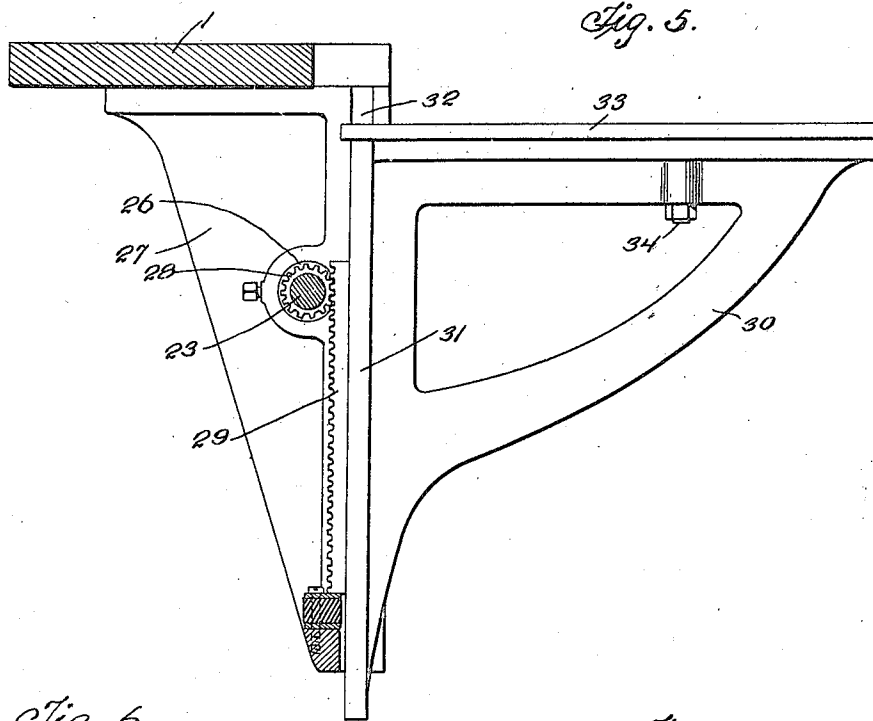

Inventor  
A. E. Augustine  
By *his* Attorney  
*L. G. Sanford*

# UNITED STATES PATENT OFFICE.

ADDISON E. AUGUSTINE, OF HACKENSACK, NEW JERSEY, ASSIGNOR TO CHESTER MACHINE CO., INC., OF NEW YORK, N. Y., A CORPORATION OF NEW YORK.

ELEVATOR-CONTROL MECHANISM FOR ENVELOPE-MAKING MACHINES.

Application filed August 5, 1919. Serial No. 315,395.

*To all whom it may concern:*

Be it known that I, ADDISON E. AUGUSTINE, residing at Hackensack, in the county of Bergen and State of New Jersey, have invented certain new and useful Improvements in Elevator-Control Mechanism for Envelope-Making Machines, of which the following is a specification.

This invention relates to an elevator control mechanism for envelope-making machines.

An object of the invention is to provide an elevator control mechanism which is more simple and at the same time more practical and more uniformly efficient than heretofore.

Other objects and aims of the invention, more or less specific than those referred to above, will be in part obvious and in part pointed out in the course of the following description of the elements, combinations, arrangements of parts and applications of principles, constituting the invention, and the scope of protection contemplated will be indicated in the appended claims.

In the accompanying drawings which are to be taken as a part of this specification, and in which I have shown merely a preferred form of embodiment of the invention;

Figure 1 is a side elevational view of a portion of an envelope-making machine showing parts of the elevator mechanism of this invention applied thereto.

Figure 2 is a front elevational view of the structure shown in Fig. 1.

Figure 3 is an enlarged horizontal sectional view taken substantially upon the plane of line III of Fig. 2.

Figure 4 is a similarly enlarged detail view of a portion of the structure shown in Fig. 2, the hand wheel shaft appearing in Fig. 2 being illustrated in transverse section substantially upon the plane of line IV of Fig. 3.

Figure 5 is a transverse sectional view substantially upon the plane of line V of Fig. 3.

Figure 6 is an enlarged side elevational view partly in section illustrating the means of adjustment between certain parts of the structure shown in Figures 1 and 2,

Figure 7 is a horizontal sectional view taken upon the plane of line VII of Fig. 6, and

Figure 8 is a fragmentary detail sectional view taken substantially upon the plane of line VIII of Fig. 2.

Referring to the drawings for describing in detail the structure which is illustrated therein, the reference character L indicates the main frame work of the envelope making machine including a horizontal table 1. Upon the frame L is mounted a rotatable cam shaft 2 having a cam 3 fixed to rotate continuously therewith.

Upon a parallel shaft 4 carried by the frame L is arranged a supporting bracket 5 providing a movable support 6 for a rock lever 7 which carries at one end an anti-friction roller 8 in a position to be operated by the cam 3. The opposite end of the lever 7 is pivotally connected, as at 9, to the lower end of a rod 10, the upper end of which rod 10 has pivotally connected therewith, by means of a pivot pin 11, a pawl 12 arranged for engaging the teeth of a ratchet wheel 13 fixed upon a shaft 14. The shaft 14 is mounted in an elongated bearing member 15 and carries loosely a crank 16 which in turn supports the pivot pin 11 and pawl 12 so as to maintain the pawl in proper operative association with the teeth of the ratchet at all times.

A tension spring 17 is connected to the rock lever 7 so as to urge the roller 8 toward the surface of the cam 3 and at the same time to, of course, lift the rod 10 and the pawl 12.

The shape of the cam 3 is such that at each revolution of the cam a relatively depressed surface, as 18, of the cam is caused to pass beneath the roller 8. As the surface 18 passes the roller the pawl will move upwardly for engaging the next succeeding tooth of the ratchet 13. If nothing prevents the pawl 12 will move the ratchet the space of one tooth with each revolution of the cam.

A suitable adjustable stop 19 is provided in the lever 7 arranged for engaging the hub 20 of the bracket 5 for positively limiting the upward movement of the pawl.

The shaft 14, to which the ratchet 13 is fixed, carries at its opposite end a worm pinion 21 which meshes with a worm gear 22. The gear 22 is mounted loosely upon a hand wheel shaft 23 and carries one or more pawls 24 disposed for engaging the teeth of a ratchet 25 fixed rigidly with the shaft 23

so that rotation of the shaft 14 will impart a certain degree of rotation to the shaft 23 so long as the pawls 24 are in engagement with the ratchet 25.

5 The shaft 23 is disposed in a horizontal position and is mounted to rotate in bearings 26 provided upon a frame 27 fixed to and depending from the table 1. Intermediate the bearings 26 the shaft 23 carries  
10 fixed thereto a small gear 28, the teeth of which engage the teeth of a rack bar 29 which is fixed to the elevator 30.

The elevator 30 has opposite guide portions 31 received within appropriate vertical  
15 guide slots 32 provided by the frame 27, and the engagement between the rack bar 29 and the gear 28 is designed for moving the elevator upwardly in accordance with the rotation imparted to the shaft 23 from the  
20 shaft 14.

A foundation plate 33 is carried by the upper surface of the elevator 30 for receiving a pile of envelope blanks thereon. This  
25 foundation plate is preferably shaped in conformity with the envelope blanks, as clearly seen in Fig. 3 upon the drawings, and is detachably connected with the main portion of the elevator, as by a retaining screw 34, so that foundation plates of different  
30 proportions may be substituted at will.

The pawls 24 are pivotally mounted, as at 35, upon the relatively outer surface of the worm gear 22 so that their free ends are adapted to swing toward and away from the center line of the shaft 23, and therefore  
40 into and out of engagement with the teeth of the ratchet 25 which teeth project radially upon said ratchet. Each of the pawls carries a finger 36 which extend thru openings 37 in the gear 22 and extend somewhat  
45 beyond the inner or rear surface of said gear. Tension springs 38 engage the inner ends of the fingers for urging the pawls normally into engagement with the teeth of the ratchet.

The gear 22 is provided with a sleeve 39 which extends along the shaft 23 so as to provide an amply elongated bearing for said  
50 gear and at the same time to provide a suitable mounting for a collar 40 which is slidably mounted upon the exterior annular surface of the sleeve. This collar is formed with an annular groove 41 within which engages the fingers 42 of a hand operable yoke 43 with which to move the collar back and  
55 forth along the sleeve 39. The forward end of the collar is bevelled off so as to provide a cone-shaped surface 44 disposed for engaging the ends of the fingers 36 whenever the collar is moved toward said fingers.  
60

The yoke 43 is pivotally mounted, as at 45, upon the frame 27 and is fitted with an appropriately extended handle part 46 by which to move the collar at will.

65 When the collar is in the position, as

shown in Figure 3 of the drawings, that is, when it is free of engagement with the fingers 36, the springs 38 are free to exercise their function of holding the pawls in engagement with the teeth of the ratchet 25.  
70 But when the handle 46 is swung to move the collar forwardly the surface 44 serves to press the fingers 36 outwardly and thereby to positively lift and hold the pawls out of engagement with the teeth of the ratchet.  
75

Whenever the pawls are lifted out of engagement with the ratchet 25 the rotation of the gear 22 will not impart rotation to the shaft 23. By this simple arrangement it becomes unnecessary to stop the operation of  
80 the entire machine when for any reason it becomes necessary or desirable only to stop the upward movement of the elevator.

The sleeve 39 extends from the gear 22 into engagement with the shaft bearing  
85 member 26, and since this sleeve, as illustrated, is somewhat longer than the length of the collar 40, it serves as a simple and efficient spacer for defining the space within which the collar may move at all times.  
90

The fact that the cone surface 44 is annular enables it to properly cooperate with the fingers 36 irrespective of the rotary position of the fingers relatively to said surface. At the same time the gear 22 with said fingers  
95 will be allowed to rotate freely with said fingers rubbing around the cone surface. The collar 40 being free to rotate upon the sleeve 39 may permit unobstructed rotation of the gear 22 while said collar is in its forward  
100 position even without the fingers rubbing upon the cone surface. In this way double precaution is provided against the possibility of obstruction to the free rotation of the gear 22 at all times.  
105

A hand wheel G is fixed to the outer end of the shaft 23 so that said shaft may be turned at will whenever it is desired to move the elevator irrespective of the automatic driving mechanism above described. When  
110 it is desired to rotate the shaft for lowering the elevator it is, of course, necessary first to move the handle 46 for disconnecting the pawls 24 from the ratchet 25, but when it is desired to raise the elevator this may be  
115 done without disconnecting the pawls since rotation of the shaft in a direction for lifting the elevator will simply cause the teeth of the ratchet 25 to click backwardly beneath the ends of the pawls.  
120

With the mechanism as thus far described it will be apparent that rotation of the cam 3 and the consequent step by step rotation of the shaft 14, will cause the elevator 30 to be  
125 lifted one step at each rotation of the cam while the pawls 24 are in cooperative relation with the ratchet 25.

The upward movement of the elevator thus provided for is, however, too rapid for other parts of the machine, hence it is neces-  
130

sary to provide a governor device designed for reducing the speed at which the elevator is lifted. This governor device, as herein illustrated, preferably includes a mechanism 5 of a character to allow the elevator to be moved upwardly in response to only a portion of the rotations of the cam 3. In order to carry out this purpose a feeler member H is provided, the same comprising a lever 10 pivotally mounted intermediate its ends, as at 47, in a standard 48 carried by the table 1. This feeler member has an end surface 49 disposed for resting upon the upper surface 50 of the pile of envelope blanks. The 15 opposite end of the feeler is pivotally connected, as at 51, to the upper end of a rod 52 which rod extends downwardly into pivotal connection with the pivot pin 11 already described as carrying the pawl 12.

20 By this arrangement it will be apparent that the extent of upward movement of the pawl 12 for engaging a successive tooth of the ratchet 13 will depend upon the possible downward movement of the surface 49 of the feeler and that this downward movement of the surface 47 will be governed by the level of the pile of envelope blanks. Thus, when the elevator with its pile of envelope blanks has been moved up one step, 30 if the succeeding upward movement of the rods 10 and 52 is arrested by engagement of the surface 49 with the pile 50 before the pawl 12 manages to engage the succeeding tooth of the ratchet 13, then the continued rotation of the cam 3 will draw the pawl 12 downwardly idly, that is, without imparting any rotation to the shaft 14. This idle operation will be repeated until such time as the level of the pile of envelope 40 blanks has been reduced sufficiently to permit the pawl 12 to rise to the point necessary for engaging the next tooth of the ratchet 13. What may be termed an active operation then follows. Idle and active operations then follow in accordance with the level 45 of the blanks.

Any suitable means may be employed for adjusting the position of the surface 49 relative to the pivot 11. The means illustrated, 50 however, has been found to be simple, efficient and satisfactory and it includes a guide member 53 which is fixed rigidly at the upper end of the shaft 52 and which carries a separately formed part 54 providing the pivotal connection between the shaft 52 and the 55 feeler H. The member 54 is mounted to slide vertically within a slot 55 formed within the member 53 and is provided with a pivot lug 56 over which the end 57 of the feeler H pivotally engages. Retaining means, as 58, is provided for retaining the part 57 against disengagement from the 60 lug 56.

65 The upper end of the slot 55 is closed by a cross member 59 which is apertured, as at

60, to receive an adjusting screw 61 there-  
thru. Opposite collars 62 are provided upon  
the screw for preventing longitudinal move-  
ment of the screw within the aperture 60.  
The threaded portion of the screw is received 70  
within a threaded aperture 63 formed thru  
the member 54 so that rotation of the screw  
will serve to move the member 54 longi-  
tudinally along the length of the slot. The  
member 54 is preferably split, as at 64, and 75  
provided with tightening means 65 thru the  
medium of which the member 54 may be  
held rigid with the screw in any position of  
vertical adjustment to which it has been  
moved. 80

Thru the utilization of this means of ad-  
justment the exact point to which the sur-  
face 49 must move in order to enable the  
pawl 12 to engage a succeeding tooth of the  
ratchet 13 may be readily determined and 85  
altered in accordance with the requirements  
of the associated functional features of the  
machine.

A further adjustment of parts is provided  
for in the manner in which the bracket 5 90  
carrying the pivot 6 for the rock lever 7  
is supported. This bracket, as illustrated,  
is mounted upon the shaft 4. Whenever  
found necessary this bracket may be rotated  
to a greater or less extent about the shaft 95  
4 for altering the precise position of the pivot  
6. A suitable set screw, or the like, as 66,  
is provided for retaining the bracket fixed in  
any position to which it is moved.

As many changes could be made in this 100  
construction without departing from the  
scope of the invention as defined in the fol-  
lowing claims, it is intended that all matter  
contained in the above description or shown  
in the accompanying drawings, shall be in- 105  
terpreted as illustrative only and not in a  
limiting sense.

The gear wheel 22, being loose upon the  
shaft and being adapted to be connected to  
and disconnected from the shaft at the will 110  
of the operator, is hereinafter referred to  
as the drive wheel for the shaft.

It will, of course, be understood that the  
pile of envelope blanks resting upon the  
foundation plate 33 is being continually di- 115  
minished by having blanks taken from the  
top thereof to be operated upon by other ele-  
ments of the machine not forming a part of  
the present invention and, therefore, not  
illustrated herein. After the pile has be- 120  
come exhausted the lever 46 is thrown to  
disconnect the drive wheel 22 from the shaft  
23 whereupon the shaft is rotated, by means  
of the hand wheel G, to depress the elevator  
30. A new pile of blanks is then placed 125  
upon the foundation plate 33 and the whole  
moved upwardly until the level of the pile  
is in approximately correct position. The  
lever 46 is then returned to connect the drive  
wheel 22 with the shaft 23, and thereafter 130

the operation of the device continues as has already been described.

The elongated bearing member 15 is preferably split at one point in its length, as at 5 67, and provided with adjustable tightening means so that the fit of the shaft 14 within the bearing member may be properly and correctly adjusted to provide a desired frictional grip upon the shaft so that said shaft 10 may be prevented from having any movement except such movement as is positively applied thereto by the pawl 12; that is, the frictional grip may be adjusted so as to hold the shaft exactly in the position to which it 15 is moved by the pawl.

Having thus described my invention, what I claim as new and desire to secure by Letters Patent is;

1. In elevator control mechanism for envelope-making machines, an elevator adapted for supporting a pile of envelope blanks, means for moving the elevator upwardly so as to maintain the level of the blanks, including a rotating shaft, connections between the elevator and the shaft for imparting a step by step movement to the elevator, a lever having a portion adapted to engage the upper surface of the pile of envelope blanks, a link extending between said lever and said connections for rendering the connections inoperative in accordance with the level of the pile, means adjustably connecting said lever and said link whereby to determine the point at which said lever becomes effective upon said connections, said last means comprising a member fixed to said link and having a slot therein, a member pivotally engaging said lever extending into said slot, and a screw engaging between said two members for adjusting the second member longitudinally of the slot by rotation of the screw.

2. In elevator control mechanism for envelope-making machines, an elevator adapted for supporting a pile of envelope blanks, means for moving the elevator upwardly including a rotatably mounted shaft, a ratchet fixed to said shaft, a member rotatably about the shaft, a part carried by said mentioned member yieldingly engaging said ratchet whereby rotation of said member will rotate said shaft, means to rotate said member, and means manually operable at will to hold said part out of engagement with said ratchet while not preventing rotation of said mentioned member, and means whereby rotation of the shaft will move the elevator.

3. In elevator control mechanism for envelope-making machines, an elevator adapted for supporting a pile of envelope blanks, means for moving the elevator upwardly including a rotatably mounted shaft, a drive wheel for the shaft mounted loosely upon the shaft, a ratchet wheel fixed to the shaft, a pawl carried by the drive wheel pivotally

mounted thereon to yieldingly engaging the ratchet wheel, a member movable in a direction longitudinally of the shaft for controlling the relation of said pawl to said ratchet, and means to manually move the last member.

4. In elevator control mechanism for envelope-making machines, an elevator adapted for supporting a pile of envelope blanks, means for moving the elevator upwardly including a rotatably mounted shaft, a drive wheel for the shaft mounted loosely upon the shaft, pawl and ratchet mechanism operative between the drive wheel and the shaft for rotating said shaft by said drive wheel, comprising a ratchet wheel whose teeth project radially therefrom and a pawl pivotally mounted upon said drive wheel having its teeth engaging part arranged to swing radially of said drive wheel into and out of engagement with the teeth of the ratchet wheel, and a member mounted to slide longitudinally of the shaft for controlling said pawl and ratchet mechanism.

5. In elevator control mechanism for envelope-making machines, an elevator adapted for supporting a pile of envelope blanks, means for moving the elevator upwardly including a rotatably mounted shaft, a drive wheel for the shaft mounted loosely upon the shaft, having a sleeve extending therefrom providing an elongated bearing for the wheel upon the shaft, a pawl and ratchet mechanism operative between the drive wheel and the shaft for rotating said shaft by said wheel, a collar mounted upon said sleeve to slide longitudinally thereof, means for sliding said collar, and means whereby the effectiveness of said pawl and ratchet mechanism is dependent upon the position of said collar.

6. In an elevator control mechanism for envelope-making machines, an elevator adapted for supporting a pile of envelope blanks, means for moving the elevator upwardly including a rotatably mounted shaft, a drive wheel for the shaft mounted loosely upon the shaft, a ratchet wheel fixed to the shaft, a pawl carried by the drive wheel at one side thereof yieldingly engaging the ratchet wheel, a finger extending from the pawl thru an opening in the drive wheel to the opposite side of said drive wheel, and manually operable means movable into and out of engagement with said finger for controlling the engagement of the pawl with the ratchet.

7. In elevator control mechanism for envelope-making machines, an elevator adapted for supporting a pile of envelope blanks, means for moving the elevator upwardly including a rotatably mounted shaft, a bearing member for said shaft, a drive wheel for the shaft mounted loosely upon the shaft spaced from said bearing member, said drive wheel having a sleeve extending therefrom

into proximity with said bearing member and providing an elongated bearing for the wheel upon the shaft, a pawl and ratchet mechanism operative between the drive wheel and the shaft for rotating said shaft by said wheel, and a collar mounted loosely upon said sleeve being of less length than said sleeve and being slidable longitudinally of the sleeve between the wheel and the bearing member, means to slide said collar, and means whereby the effectiveness of said pawl and ratchet mechanism is dependent upon the position of said collar.

8. In elevator control mechanism for envelope-making machines, an elevator adapted for supporting a pile of envelope blanks, and means for imparting a step by step upward movement to the elevator including a rotating shaft, a pawl and ratchet device, a cam carried by said shaft, a lever associated with the cam to be oscillated thereby, a link extending from said pawl and ratchet device to said lever, and elevator lifting mechanism connected to be operated by said pawl and ratchet device, together with a governor device for controlling the effectiveness of the pawl and ratchet device in accordance with the level of the pile of envelope blanks, said governor device including a member adapted to engage the upper surface of the pile of envelope blanks, and a second link extending from said member into direct connection with said pawl and ratchet device.

9. In elevator control mechanism for envelope-making machines, an elevator adapted for supporting a pile of envelope blanks, and means for imparting a step by step upward movement to the elevator including a pawl and ratchet device, a member movable in one direction to cause the pawl to engage one tooth of, and to thereby rotate, the ratchet, said member being movable in the opposite direction to return the pawl for engaging a second tooth of the ratchet, means to move said member, a governor device automati-

cally controlled by the level of the pile of envelope blanks for determining the extent of movement of said member in said opposite direction, and a further device manually adjustable at will also to determine the extent of movement of said member in said opposite direction while not effecting limit of movement of said member in said first direction.

10. In elevator control mechanism for envelope-making machines, an elevator adapted for supporting a pile of envelope blanks, and means for imparting a step by step upward movement to the elevator including a pawl and ratchet device, a shaft arranged to be rotated by said pawl and ratchet device, a bearing member for said shaft, said bearing member being split, and means whereby to squeeze the parts of the bearing member together for gripping the shaft so as to frictionally retard the movements of the shaft.

11. In elevator control mechanism for envelope-making machines, an elevator for supporting a pile of envelope blanks, means for moving the elevator upwardly including a rotatably mounted shaft, a drive wheel for the shaft, a ratchet wheel fixed to the shaft, a pawl carried by the drive wheel at one side thereof adapted to engage the drive wheel, a finger extending from the pawl through an opening in the drive wheel to the opposite side of said drive wheel, means engaging said finger at said opposite side of the drive wheel for yieldingly maintaining the pawl in engagement with the ratchet wheel, and means also at said opposite side of the drive wheel operative upon said finger for controlling the engagement of the pawl with the ratchet.

In testimony whereof I affix my signature in the presence of two witnesses.

ADDISON E. AUGUSTINE.

Witnesses:

L. GINFORD HANCHE,  
MAX SCHULZ.