



INTERNATIONAL APPLICATION PUBLISHED UNDER THE PATENT COOPERATION TREATY (PCT)

<p>(51) International Patent Classification ⁶ : H01C 7/12</p>	<p>A1</p>	<p>(11) International Publication Number: WO 98/38653 (43) International Publication Date: 3 September 1998 (03.09.98)</p>
<p>(21) International Application Number: PCT/GB98/00598 (22) International Filing Date: 25 February 1998 (25.02.98) (30) Priority Data: 9703861.6 25 February 1997 (25.02.97) GB 9724126.9 14 November 1997 (14.11.97) GB (71) Applicant (for all designated States except US): BOWTHORPE INDUSTRIES LIMITED [GB/GB]; Gatwick Road, Crawley, West Sussex RH10 2RZ (GB). (72) Inventors; and (75) Inventors/Applicants (for US only): DOONE, Rodney, Meredith [GB/GB]; 77B Folders Lane, Burgess Hill RG15 0DY (GB). SHORT, Patrick, George [GB/GB]; 12 The Holt, Burgess Hill, West Sussex RH15 0RF (GB). (74) Agents: MILHENCH, Howard, L. et al.; R.G.C. Jenkins & Co., 26 Caxton Street, London SW1H 0RJ (GB).</p>	<p>(81) Designated States: AL, AM, AT, AU, AZ, BA, BB, BG, BR, BY, CA, CH, CN, CU, CZ, DE, DK, EE, ES, FI, GB, GE, GH, GM, GW, HU, ID, IL, IS, JP, KE, KG, KP, KR, KZ, LC, LK, LR, LS, LT, LU, LV, MD, MG, MK, MN, MW, MX, NO, NZ, PL, PT, RO, RU, SD, SE, SG, SI, SK, SL, TJ, TM, TR, TT, UA, UG, US, UZ, VN, YU, ZW, ARIPO patent (GH, GM, KE, LS, MW, SD, SZ, UG, ZW), Eurasian patent (AM, AZ, BY, KG, KZ, MD, RU, TJ, TM), European patent (AT, BE, CH, DE, DK, ES, FI, FR, GB, GR, IE, IT, LU, MC, NL, PT, SE), OAPI patent (BF, BJ, CF, CG, CI, CM, GA, GN, ML, MR, NE, SN, TD, TG).</p> <p>Published With international search report. Before the expiration of the time limit for amending the claims and to be republished in the event of the receipt of amendments.</p>	

(54) Title: IMPROVEMENTS RELATING TO ELECTRICAL SURGE ARRESTERS

(57) Abstract

An electrical surge arrester is manufactured by securing a stack of metal oxide varistor blocks between end terminations by passing a rod through through-holes in the varistor blocks and securing the ends of the rod to the end terminations. The through-holes are larger than the rod cross section and a silicone rubber material is injected into the void which otherwise would exist between the rod and the interior surfaces of the through-holes in the varistor blocks. The silicone rubber material is also moulded around the exterior of the stacked varistor blocks and forms a shedded external housing for the arrester. The silicone rubber coatings on the varistor block internal and external surfaces effects a passivation function and means that the passivation coatings normally provided on the surfaces of varistor blocks by their manufacturers at significant cost can be omitted.

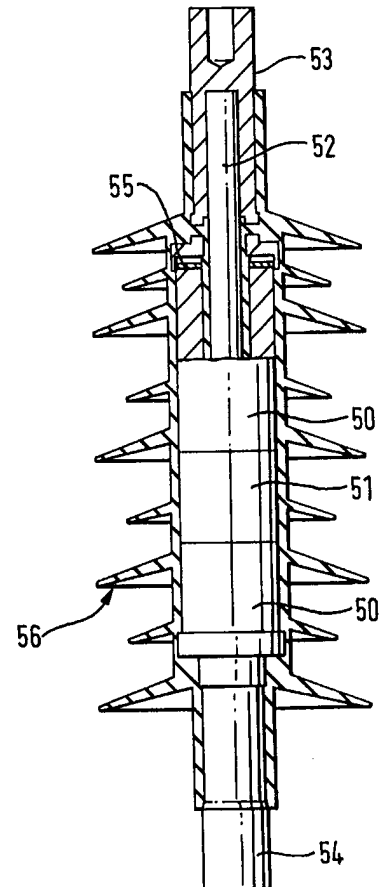

FOR THE PURPOSES OF INFORMATION ONLY

Codes used to identify States party to the PCT on the front pages of pamphlets publishing international applications under the PCT.

AL	Albania	ES	Spain	LS	Lesotho	SI	Slovenia
AM	Armenia	FI	Finland	LT	Lithuania	SK	Slovakia
AT	Austria	FR	France	LU	Luxembourg	SN	Senegal
AU	Australia	GA	Gabon	LV	Latvia	SZ	Swaziland
AZ	Azerbaijan	GB	United Kingdom	MC	Monaco	TD	Chad
BA	Bosnia and Herzegovina	GE	Georgia	MD	Republic of Moldova	TG	Togo
BB	Barbados	GH	Ghana	MG	Madagascar	TJ	Tajikistan
BE	Belgium	GN	Guinea	MK	The former Yugoslav Republic of Macedonia	TM	Turkmenistan
BF	Burkina Faso	GR	Greece	ML	Mali	TR	Turkey
BG	Bulgaria	HU	Hungary	MN	Mongolia	TT	Trinidad and Tobago
BJ	Benin	IE	Ireland	MR	Mauritania	UA	Ukraine
BR	Brazil	IL	Israel	MR	Mauritania	UG	Uganda
BY	Belarus	IS	Iceland	MW	Malawi	US	United States of America
CA	Canada	IT	Italy	MX	Mexico	UZ	Uzbekistan
CF	Central African Republic	JP	Japan	NE	Niger	VN	Viet Nam
CG	Congo	KE	Kenya	NL	Netherlands	YU	Yugoslavia
CH	Switzerland	KG	Kyrgyzstan	NO	Norway	ZW	Zimbabwe
CI	Côte d'Ivoire	KP	Democratic People's Republic of Korea	NZ	New Zealand		
CM	Cameroon	KR	Republic of Korea	PL	Poland		
CN	China	KZ	Kazakstan	PT	Portugal		
CU	Cuba	LC	Saint Lucia	RO	Romania		
CZ	Czech Republic	LI	Liechtenstein	RU	Russian Federation		
DE	Germany	LK	Sri Lanka	SD	Sudan		
DK	Denmark	LR	Liberia	SE	Sweden		
EE	Estonia			SG	Singapore		

Improvements Relating to Electrical Surge ArrestersField of the Invention:

This invention concerns improvements relating to electrical surge arresters, also known as surge diverters, which, as is well known, are used in high voltage electric installations for providing a path to ground for surge overvoltages occasioned for example by lightning strikes and as switching transients.

Background of the invention:

In GB-A- 2188199 there is described a surge arrester which is primarily intended for use in distribution class applications, but can be coupled with other electrically matched arresters in a series parallel arrangement for higher voltage station class applications as described in GB-A- 2230661. This surge arrester comprises a rigid core of great physical strength upon which there is provided a shedded outer housing of polymeric material, the core consisting of a plurality of ceramic varistor blocks stacked end to end and encased within a shield of reinforced rigid plastics material. The reinforced rigid plastics material shield is preferably bonded directly to the external surface of the varistor block stack, though proposals have been made to provide a thin spacing layer of MylarTM between the varistor blocks and the shield. There may be a number of metal (eg aluminium) spacer blocks incorporated into the varistor block stack for the purpose of providing the stack with an overall length sufficient to avoid flashover externally

of the arrester and terminal blocks are provided at opposite ends of the stack for enabling the coupling of the arrester to associated equipment.

As described in GB-A- 2188199 the rigid core and polymeric housing of the surge arrester provides significant advantages as compared to porcelain housed surge arresters which have long suffered a fragility problem. Conventional

5 porcelain housed surge arresters commonly have an inert gas filling which can literally blow the arrester housing apart if the arrester is subjected to an excessive overvoltage, littering the surrounding area with hot fragments and causing fires.

Pressure relief rupturable diaphragms can be provided in the end cap arrangements of gas filled porcelain housed surge arresters, but these provisions complicate the

10 arrester construction and the fragility problem of the porcelain housing still remains.

The rigid cored, polymer housed, gapless surge arrester of GB-A- 2188199 is manufactured to avoid gaseous inclusions and retains its structural integrity even under failure. Additionally, it enables support insulators to be dispensed with, since

15 the rigid core of the arrester is sufficiently strong to support the loading which conventionally is supported by the provision of support insulators. The inherent strength of the arrester of GB-A- 2188199, which results from its rigid core and gapless construction, enables it to be coupled into a series parallel array capable of handling station class voltages as described in GB-A- 2230661. As a result of these

20 and other advantages, the surge arrester of GB-A- 2188199 has enjoyed considerable commercial success.

Notwithstanding the success of the surge arresters of GB-A- 2188199 and GB-A- 2230661 we have, as a part of our continuous improvement strategy, considered how component costs, assembly times and manufacturing process times might be reduced. The manufacture of surge arresters in accordance with GB-A- 2188199 requires curing processes to cure the reinforced epoxy material that is applied to the varistor block stack in an uncured state and, if a silver loaded adhesive is provided between the contiguous faces of the stacked blocks to improve electrical contact therebetween, additionally requires a curing process for the adhesive. After curing, the core assembly is then sleeved with its polymeric housing in a separate operation and finally end caps are fitted. The manufacturing time required for these processes is considerable and demands the availability of curing ovens, and a manufacturing technique which could eliminate the curing process would show considerable benefit in manufacturing space and time. Any reduction in component costs would be an added bonus.

Objects and Summary of the Invention:

It is, accordingly, the object of the present invention to provide an electrical surge arrester which can be more readily manufactured than the surge arrester of GB-A- 2188199 without prejudice to the advantages demonstrated by that surge arrester.

The present invention stems primarily from the realization that the external passivation coating that is invariably provided by manufacturers of metal oxide

varistor blocks on all surfaces of the blocks other than their metallized contact surfaces can in fact be dispensed with, thereby leading to a reduction in component costs. Varistor blocks conventionally are solid circularly cylindrical in shape with metallized contact coatings on their circular axially end faces and passivation coatings on their cylindrical external surfaces, the passivation coating comprising an epoxy resin or glass or a separately fitted electrically insulating collar. The passivation coating enables a varistor to be used to its full electrical capability by avoiding external flashover problems between the contact surfaces, and its provision is also useful to the manufacturer in that it enables classification and quality control operations to be conducted. However, the provision of the passivation coating significantly contributes to the manufacturing cost of varistor blocks.

If the need for a passivation coating can be dispensed with, then the limitations that the need for a passivation coating have imposed upon the shapes of varistor blocks can also be dispensed with. The process by which passivation coatings are most economically provided on varistor blocks is to spray an epoxy resin or glass material on to the surface of the varistor block and then to bake the varistor in an oven until the resin is cured on to the varistor surface or until the glass material has sintered on to the varistor body. This process has hindered the production hitherto of varistor blocks with through holes, since the manufacture of a varistor block with a through hole and with an effective passivation coating on the

surface of the through hole would impose additional difficulties for the varistor block manufacturer.

By dispensing with the passivation coating, varistor blocks with through holes, for example an axial through hole, can be manufactured at reasonable cost. A stack of such varistor blocks can then be retained in face-to-face contact between end terminations by means of an electrically-insulating rod appropriately secured to the end terminations and the present invention proposes to take advantage of such an arrangement. A surge arrester comprising varistor blocks with axial through holes which are retained in a stacked configuration and supported by an electrically insulating rod has previously been proposed in GB-A- 2073965 but has not been manufactured. Other surge arresters wherein varistor blocks have a supportive rod extending through holes in the blocks are proposed in US-A-4262318, EP-A-0141239, US-A-4825188 and WO-A-95/10846. The surge arresters of US-A-4 262 318 and EP-A-0 141 239 are of the previously mentioned porcelain housed type wherein the physical strength of the arrester, such as it is, is provided by the porcelain housing. The surge arrester of US-A-4 825 188 has a similar construction to a surge arrester embodying to the present invention as hereinafter described, but US 4 825 188 does not disclose or suggest the present invention. Likewise WO-A-95/10846 discloses a similar surge arrester but does not disclose or suggest the present invention.

In accordance with the present invention, a stack of non-passivated varistor elements is retained in face-to-face contact between end terminations by means of an electrically insulating rod passed through through-holes in the varistor elements and secured to the end terminations, the through-holes and the rod are sized such that there is a clearance between the surface of the rod and the surrounding surface of the through-holes, and a silicone rubber material fills the void that otherwise would exist between the rod and the varistor blocks and extends around the external surfaces of the varistor blocks, the silicone rubber material serving as a passivation coating for the varistor blocks.

The silicone rubber material can be injected in liquid form and will cure into a solid without external intervention. The external configuration of the silicone rubber on the outside of the arrester can advantageously include integral sheds to increase the external tracking distance of the arrester between the end terminations and to serve a weather shedding function. Alternatively the silicone rubber on the outside of the arrester could have a circular cylindrical surface and a separate shedded outer housing, formed for example of heat shrink polymeric material or of a mechanically released elastomeric material or of an in situ moulded plastics material, could be provided on the arrester, though this is not preferred in view of the additional manufacturing steps that would be required.

The invention also extends to a method of manufacturing a surge arrester comprising securing a plurality of non-passivated varistor blocks between end

terminations by passing an electrically insulating rod through aligned through-holes in the varistor blocks and securing the rod to the end terminations, the through-holes in the varistor blocks being larger than the rod cross-section, injecting a liquid silicone rubber material into the void between the rod and the surfaces of the through-holes in the varistor blocks and around the external surfaces of the stacked varistor blocks, the liquid silicone material being selected to serve a surface passivation function on the varistor blocks, and permitting the silicone rubber material to solidify.

The through-holes in the varistor blocks are preferably axial, since this permits the rod to locate centrally with respect to the stacked varistor blocks and enables a screw-threaded connection of the ends of the rod to the terminations to be utilized. It is however not inconceivable that a crimp type or lock screw type of attachment of the terminations to the through rod might be utilized. The rod is preferably axial, but could be off axis, and also there might be more than one such rod. For simplicity, however, a central, axial rod making screw-threaded or crimped attachment to the arrester terminations is preferred.

By virtue of the use of non-passivated varistor blocks a reduction is achieved in the arrester component costs. By use of appropriate assembly jigs, the varistor blocks can readily be threaded onto their central rod and secured between end terminations screw-threaded and/or compressed onto the ends of the rod. The sub-assembly thus formed can then be placed in an appropriate mould for the

injection of the silicone rubber material and a finished surge arrester comes out of the mould. Production costs can thereby be lowered as compared to production costs for the surge arrester described in GB-A- 2188199.

5 The support rod can advantageously be tensioned in the arrester construction, for example by appropriate adjustment of screw-threaded end terminations and/or by inclusion of a pre-load means (one or more Belleville washers, for example) in the varistor stack between the end terminals. This pre-loading assists the surge arrester in withstanding operational mechanical loading.

10 Tests that we have conducted have established that suitable electrical grade silicone rubber material, for example SILOPREN™ LSR available from Bayer, satisfactorily effects passivation of the varistor block surfaces. EPDM, disclosed in US-A-4 825 188, is not a suitable material for this purpose.

15 The above and further features of the present invention are set forth in the appended claims and will be made clear from consideration of the following detailed description given with reference to the accompanying drawings.

Description of the Drawings:

Figure 1a is a perspective view of a conventional metal oxide varistor block shown cut in half to reveal its construction;

20 Figure 1b is a similar perspective view of an exemplary metal oxide varistor block employed in the practice of the present invention;

Figure 2a is a perspective view of an exemplary surge arrester constructed according to the teachings of the present invention, the arrester being shown longitudinally cut in half to reveal its internal construction and with its internal components axially spaced apart.

5 Figure 2b is a sectional elevational view of the surge arrester shown in Figure 2a;

Figure 3a shows an arrester core sub-assembly constructed as an intermediate phase in the manufacture of a surge arrester as shown in Figures 2a and 2b, and one half of a liquid silicone rubber injection moulding system;

10 Figure 3b shows the core sub-assembly received within the mould in preparation for the application of an upper mould part and injection of liquid silicone rubber material;

Figure 4 is a cut-away view of another surge arrester embodying the present invention; and

Figure 5 is an exploded view of the surge arrester of Figure 4.

15 Detailed Description of the Embodiment:

Referring first to Figures 1a and 1b, the former of these figures illustrates the construction of a conventional metal oxide varistor as utilized for example in the polymer housed surge arrester of GB-A- 2188199 or in prior and contemporaneous porcelain housed surge arresters, and the latter figure illustrates
20 the construction of a metal oxide varistor for use in the practice of the present invention. As shown, the conventional varistor has a solid circular cylindrical

ceramic body 1 formed of Zinc Oxide for example, metallised contacts 2 provided at the axial end surfaces of the ceramic body 1 and a passivation coating 3 provided on the cylindrical surface of the body 1. As mentioned previously, without the passivation coating 3, the varistor could not be used to its full electrical capability without causing a flashover externally of the varistor body 1 between the edges of the metallised contact surfaces 2. Without the benefit of the passivation coating, the electrical strength of the varistor is weakest at its external surface. The varistor of Figure 1b has no passivation coating and is formed with a central axial through hole 4.

Figures 2a and 2b show an exemplary surge arrester constructed in accordance with the teachings of the present invention. A plurality of metal oxide varistor elements 15, each as shown in Figure 1b, are retained in stacked end to end configuration between end terminations 13 by means of an electrically insulating compression rod 11, formed of glass reinforced plastics material for example, which extends through the through holes 4 of the varistor elements 15 and engages screw-threadedly with the end terminations 13. Soft metal contact discs 14, formed of copper for example, may be provided between the varistor blocks 4 and between the end varistor blocks and the end terminations 13 for distributing the compressive load that is developed as the end terminations 13 are tightened onto the ends of the compression rod 11 and for ensuring a close seal between contiguous electrical contact surfaces.

The axial through holes 4 in the varistor elements 15 are larger than the cross-sectional dimensions of the rod 11 so that a clearance spacing exists within and throughout the length of the varistor block stack between the varistor blocks and the rod. As will be described more particularly hereinafter and as shown in Figure 2b, this clearance spacing is filled with silicone rubber fluid 12 when the sub-assembly of the varistor blocks 15, the contact disks 14, the rod 11 and the end terminations 13 are placed in a mould into which silicone rubber material in fluid state is injected, the mould including cavities for receiving the sub-assembly such that not only is mould fluid injected into the centre of the surge arrester, but also it is injected around the outside of the sub-assembly so that, when it cures, it forms a shedded integral external housing 16 for the arrester. Externally screw threaded terminal studs 17 are screw threadedly engaged with the end terminations 13 of the arrester for enabling the arrester to be coupled to associated equipment.

As shown in Figure 2b, the silicone rubber material coats the internal surfaces of the through holes in the varistor blocks and also coats their external cylindrical surfaces. Tests that we have conducted have shown that unpassivated metal oxide varistors when completely surrounded with a suitable grade of silicone rubber, for example Bayer's SILOPHRENTM LSR, behave in the same or a substantially similar manner as conventionally manufactured varistors provided with surface passivation.

The surge arrester of Figure 2b has a gapless, solid state configuration with no voids or internal gaseous entrapments. It has high strength, similar to the surge arrester of GB-A-2 188 199, thanks to the reinforced plastics compression rod 11. From an electrical standpoint, it promises to meet all of the standards requirements.

5 Moreover, as described in the following, it can be manufactured more economically than can the surge arrester of GB-A-2 188 199.

Figures 3a and 3b illustrate the silicone rubber moulding operation, which relies upon standard silicone rubber moulding techniques. Figure 3a shows the sub-assembly 21 constituted by the varistor blocks 15 and contact disks 14 assembled
10 between the end terminations 13 and retained by the compression rod 11, and also shows the lower half 23 of an injection mould tool adapted to receive the sub-assembly 21, the upper half of the tool being a mirror image of the lower half. The mould tool 23 has a cavity 30 shaped to receive the sub-assembly 21 as shown in Figure 3b, with the shoulders 13' of the end terminations 13 fitting sealingly into the
15 axial ends of the cavity. Injection points 24 are provided at one end of the tool for enabling silicone rubber material to be injected into the mould cavity and riser points 25 are provided at the other end of the tool. To enable silicone rubber injected into the mould cavity to access the interior of the sub-assembly 21, the end terminations 13 are provided with injection runners 22 (not shown in the preceding
20 figures) in the form of radial channels across the inner axial faces of the end

terminations 13. The tool cavity 30 further has portions 31 to produce the external sheds 16 of the finished surge arrester.

5 With the sub-assembly 21 received within the mould tool and the two halves of the tool closed about the sub-assembly, liquid silicone rubber material may be injected under pressure into the injection points 24 until it flows from the riser points 25. To aid the injection process and improve the tool filling process, suction may be applied to the riser points 25. Once filled, the silicone rubber flow to the mould is cut off and the silicone rubber within the mould is permitted to cure into its solid state. The mould may be heated to a predetermined temperature to
10 facilitate the curing of the silicone rubber material. When the silicone rubber has solidified, the mould may be opened and the finished surge arrester, as shown in Figure 2b, removed.

A surge arrester constructed and manufactured as hereinbefore described promises to provide numerous advantages, as follows:

- 15 (i) the simple construction of the arrester enables fully automated assembly techniques to be used;
- (ii) the metal oxide varistors are less expensive since no passivation coating is required to be provided by their manufacturer;
- (iii) the arrester can achieve a high mechanical strength, this being a function of
20 the mechanical strength of the compression rod holding the stacked varistor blocks between the end terminations;

(iv) only a single electrically insulating material, silicone rubber, is employed;

(v) the arrester requires a reduced number of components for its assembly, thereby reducing material and component stocks required;

5

(vi) no oven curing processes are required;

(vii) lower labour costs result from reduced operator handling;

(viii) the arrester exhibits reduced risk of fire under failure, since silicone rubber will not support combustion and the combustible compression rod is contained not only within the silicone rubber but also within the non-combustible metal oxide varistors;

10

(ix) for use as a tension insulation arrester (TISA) the axial compression can be increased to offset overhead line tension loads; and

(x) assembly techniques are easily adjustable to accommodate mechanical tolerances.

15

Having described the invention in the foregoing by reference to a specific embodiment, it is to be appreciated that modifications and variations thereto are possible without departure from the spirit and scope of the invention. For example, as in the arrester described in GB-A-2188199 metal spacer blocks may be distributed amongst the varistor blocks. Additionally, more than one compression rod could be provided, particularly perhaps in arresters of larger size having larger

20

diameter varistor blocks. Furthermore, whilst silicone rubber is the presently preferred material for use in the manufacture of the described arrester, other materials not presently known to the present inventors could also prove to be suitable.

5 Figures 4 and 5 show an embodiment of the present invention wherein spacer blocks, which serve also as heat sinks, are distributed with the varistor elements and a precompression assembly is incorporated into the arrester. As shown, metal oxide varistor elements 50 and heat sink/spacer blocks 51 formed of aluminium for example are threaded onto a glass rod pultrusion (pull extrusion) 52.

10 Steel end terminations 53 and 54 formed to be compressed onto the glass rod 52 are provided as shown and a precompression assembly 55 comprising Belleville washers is incorporated into the construction. In assembly, with the components loosely assembled onto the glass rod pultrusion 53, the assembly is put under compression so as to compress the Belleville washers 55 and the end terminations
15 are crimped onto the glass rod 52. Thereafter the assembly is inserted into a mould tool and silicone rubber is injected as previously described herein so as to fill the space between the glass rod 52 and the internal surfaces of the varistor and heat sink/spacer components and form an external shedded housing 56 on the arrester.

 The central glass rod pultrusion 52 carries all the mechanical loading that
20 the surge arrester experiences in use, and the glass rod is preloaded in tension by virtue of the provision of the precompression assembly 55 to exceed the maximum

load expected during line erection. It is possible that the precompression assembly 55 might be omitted if the glass rod pultrusion 52 were preloaded within its elastic limit and thereby maintained compression of the varistor assembly. The preload would have to be sufficient to exceed any transmission line static loads by an amount equal to the normally required maximum axial pressure on the varistors.

CLAIMS:

1. An electrical surge arrester comprising a stack of varistor elements retained between end terminations by means of an electrically insulating rod passing through through-holes in the varistor elements and secured to the end terminations, the through-holes being larger than the rod cross-section, and a moulded plastics material filling the void that otherwise would exist between the rod and the varistor elements and extending around the external surfaces of the stacked varistor blocks, the varistor elements being formed without passivation coatings on their internal and external surfaces, and said moulded plastics material being selected to provide a passivation function.
2. An electrical surge arrester as claimed in claim 1 wherein said moulded plastics material is a silicone rubber material.
3. An electrical surge arrester as claimed in claim 1 or 2 wherein the varistor elements are metal oxide ceramic elements, for example comprising Zinc Oxide.
4. An electrical surge arrester as claimed in any preceding claim wherein the electrically insulating rod is under pre-load tension in the arrester, for example by virtue of pre-load means being incorporated in the arrester construction.

5. An electrical surge arrester as claimed in any preceding claim and further comprising a shedded external housing.

6. An electrical surge arrester as claimed in claim 5 wherein the shedded external housing of the arrester is formed integrally with the moulded plastics material extending around the external surfaces of the stacked varistor blocks.

7. An electrical surge arrester as claimed in any preceding claim wherein said rod comprises a reinforced plastics material or a glass pultrusion.

10

8. An electrical surge arrester as claimed in any preceding claim wherein the rod is screw-threadedly engaged with at least one of the end terminations, or is engaged therewith by virtue of the end termination being compressed onto the rod.

15

9. An electrical surge arrester as claimed in any preceding claim including metal spacer elements distributed amongst the varistor elements.

20

10. A method of manufacturing an electrical surge arrester, said method comprising securing a plurality of varistor elements between end terminations by passing an electrically insulating rod through aligned through-holes in the varistor blocks and securing the rod to the end terminations, the through-holes in the varistor elements being larger than the rod cross-section, and injecting a plastics

moulding material into the space between the rod and the facing surfaces of the through-holes in the varistor elements and around the external surfaces of the varistor elements, the varistor elements being formed without passivation coatings on their internal and external surfaces, and the moulded plastics material being
5 selected to provide a passivation function.

11. A method as claimed in claim 10 wherein the plastics material comprises a silicone rubber material.

10 12. A method as claimed in claim 10 or 11 wherein the injection of the plastics moulding material around the external surfaces of the varistor elements is effected in such a manner that a shedded outer housing of the arrester is integrally formed.

15 13. A method as claimed in any of claims 10 to 12 wherein the varistor elements, the rod and the end terminations are first assembled into a sub-assembly, the sub-assembly thus formed is loaded into the cavity of a mould tool, and the plastics moulding material is injected into the mould tool in fluid form.

20 14. A method as claimed in any of claims 10 to 13 wherein the securing of the rod to the end terminations is effected so that the rod is under tension.

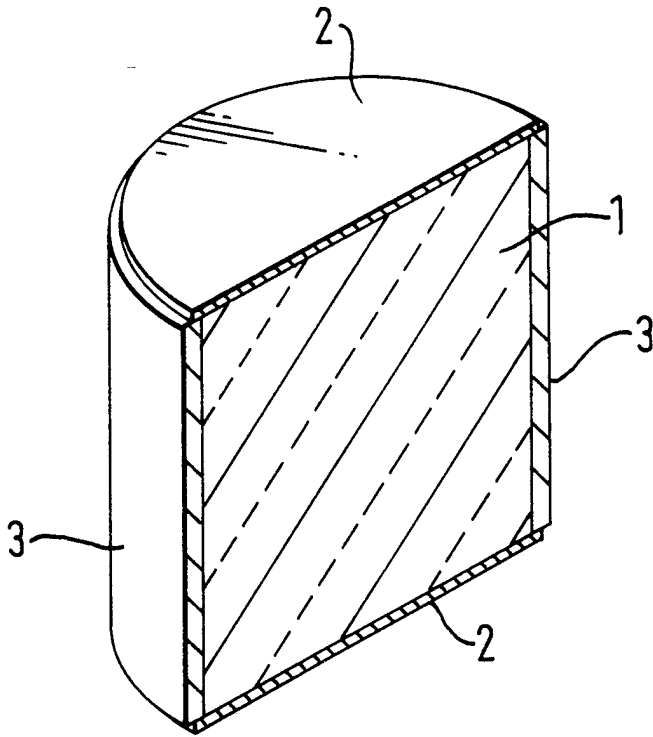

FIG. 1a

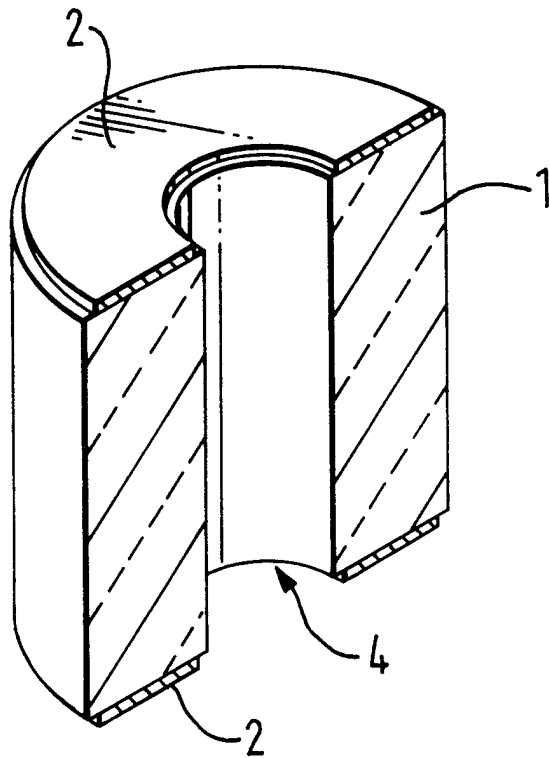

FIG. 1b

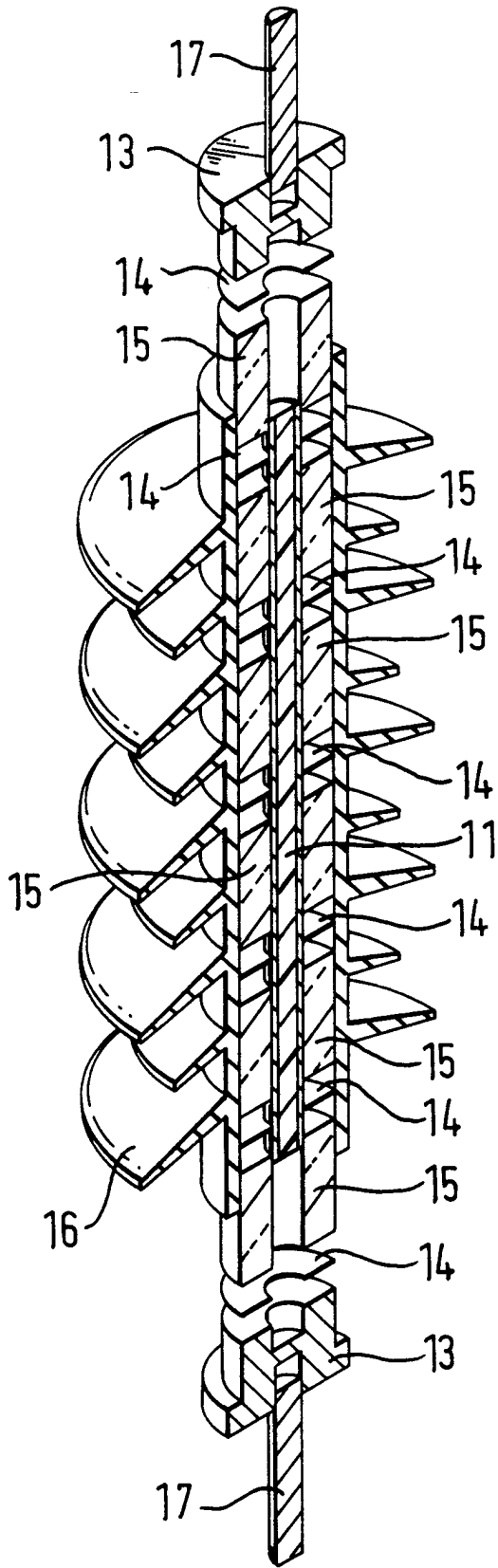

FIG. 2a

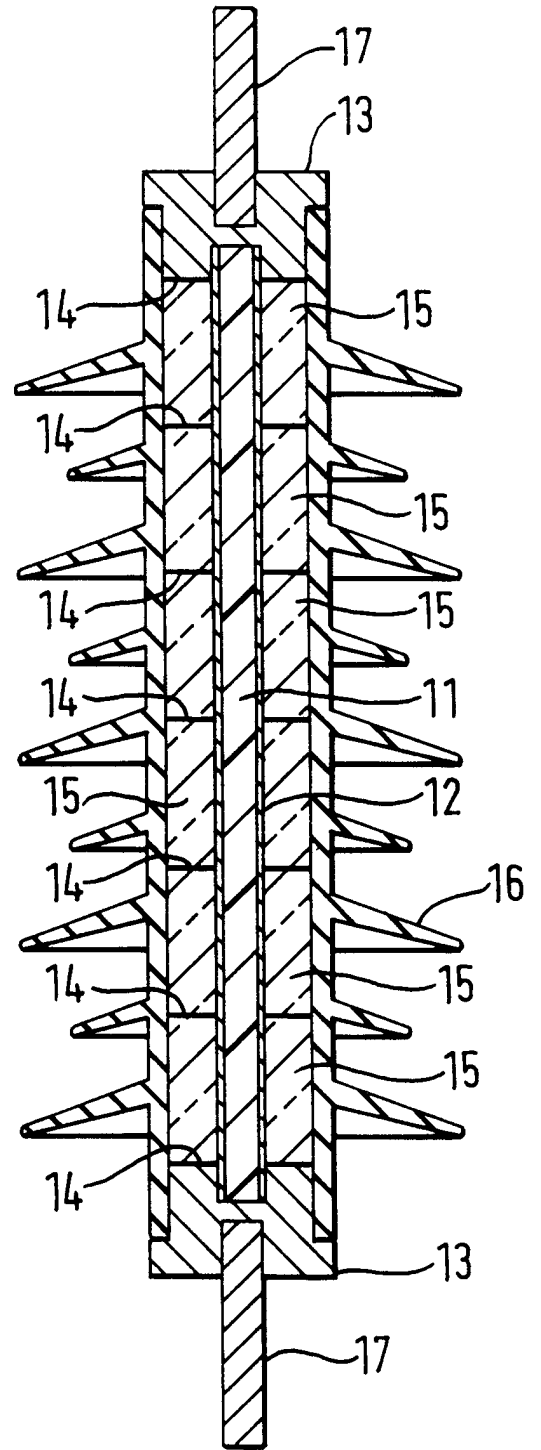

FIG. 2b

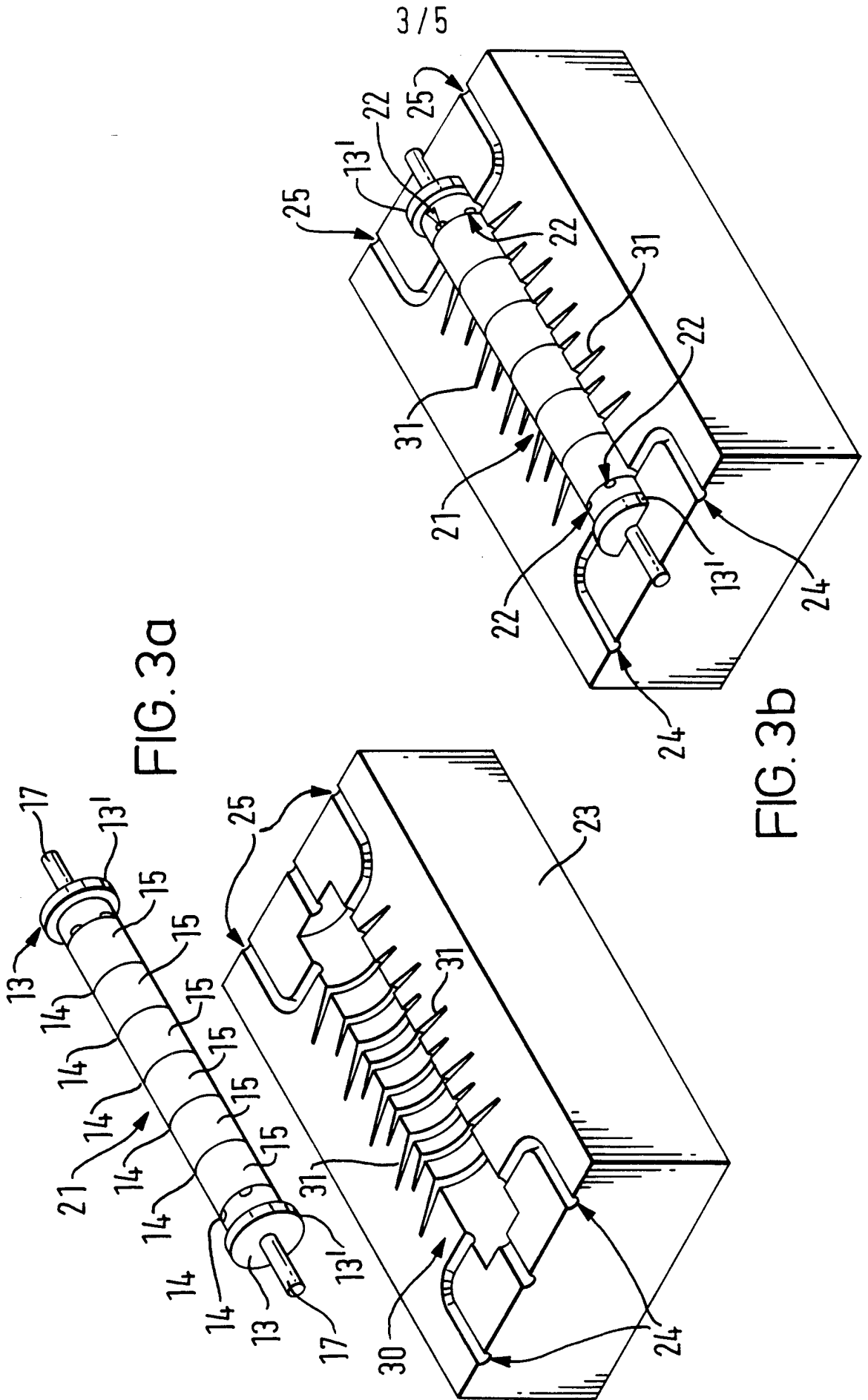

FIG. 3a

FIG. 3b

4/5

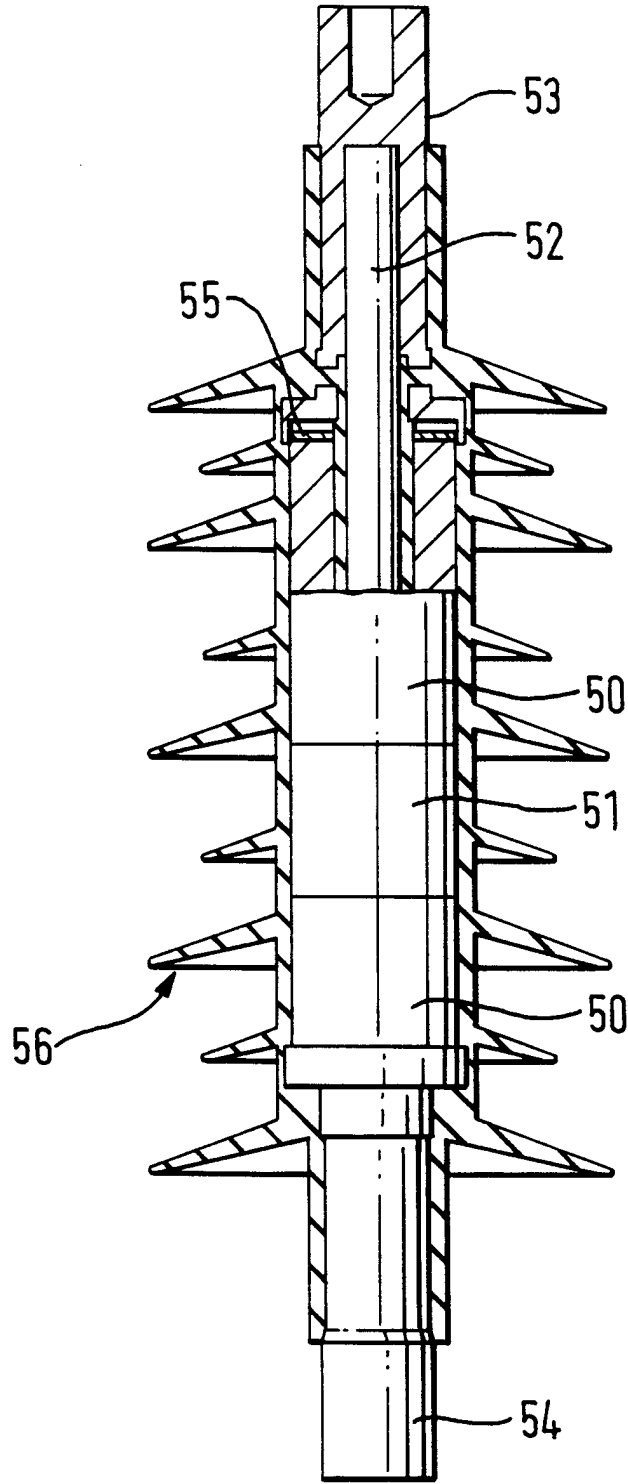

FIG. 4

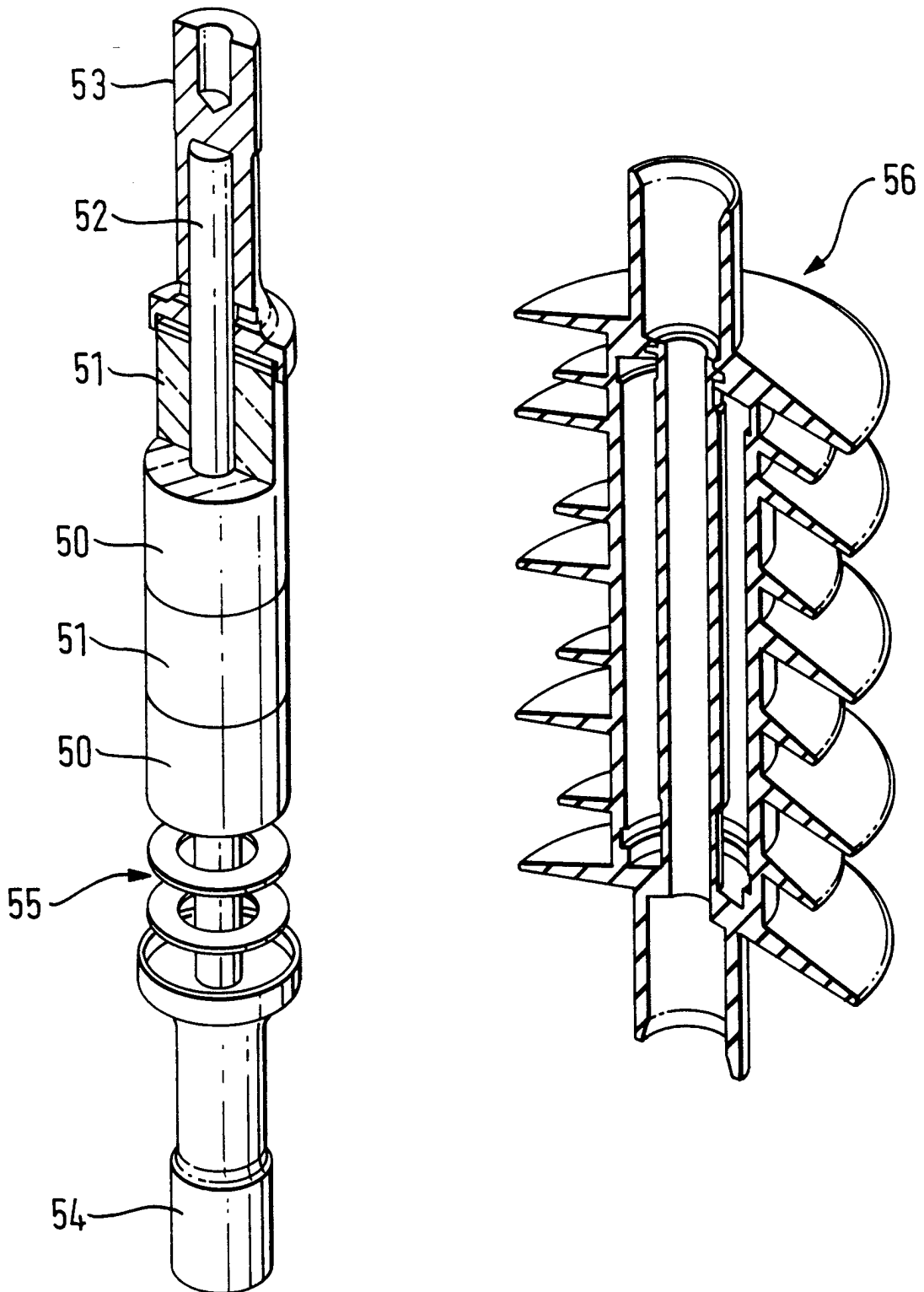

FIG. 5

INTERNATIONAL SEARCH REPORT

International Application No

PCT/GB 98/00598

A. CLASSIFICATION OF SUBJECT MATTER
IPC 6 H01C7/12

According to International Patent Classification (IPC) or to both national classification and IPC

B. FIELDS SEARCHED

Minimum documentation searched (classification system followed by classification symbols)
IPC 6 H01C

Documentation searched other than minimum documentation to the extent that such documents are included in the fields searched

Electronic data base consulted during the international search (name of data base and, where practical, search terms used)

C. DOCUMENTS CONSIDERED TO BE RELEVANT

Category	Citation of document, with indication, where appropriate, of the relevant passages	Relevant to claim No.
X	WO 95 10846 A (FURUKAWA ELECTRIC CO LTD ;SZAPLONCZAY PAL (HU); TEGLAS MARTON (HU)) 20 April 1995	1,3,5,6, 9,10,12, 13
Y	see page 3, line 20 - page 4, line 16 ---	2,11
Y	EP 0 545 038 A (ASEA BROWN BOVERI) 9 June 1993 see column 3, line 20 - line 30 see column 4, line 28 - line 39 ---	2,11
A	EP 0 726 581 A (ABB MANAGEMENT AG) 14 August 1996 see column 5, line 56 - column 6, line 10 ---	1,2,10, 11
A	US 4 825 188 A (PARRAUD RENE ET AL) 25 April 1989 cited in the application -----	1,3-10, 12,14

Further documents are listed in the continuation of box C.

Patent family members are listed in annex.

Special categories of cited documents :

- "A" document defining the general state of the art which is not considered to be of particular relevance
- "E" earlier document but published on or after the international filing date
- "L" document which may throw doubts on priority claim(s) or which is cited to establish the publication date of another citation or other special reason (as specified)
- "O" document referring to an oral disclosure, use, exhibition or other means
- "P" document published prior to the international filing date but later than the priority date claimed

- "T" later document published after the international filing date or priority date and not in conflict with the application but cited to understand the principle or theory underlying the invention
- "X" document of particular relevance; the claimed invention cannot be considered novel or cannot be considered to involve an inventive step when the document is taken alone
- "Y" document of particular relevance; the claimed invention cannot be considered to involve an inventive step when the document is combined with one or more other such documents, such combination being obvious to a person skilled in the art.
- "&" document member of the same patent family

Date of the actual completion of the international search

17 June 1998

Date of mailing of the international search report

29/06/1998

Name and mailing address of the ISA

European Patent Office, P.B. 5818 Patentlaan 2
NL - 2280 HV Rijswijk
Tel. (+31-70) 340-2040, Tx. 31 651 epo nl,
Fax: (+31-70) 340-3016

Authorized officer

Wirner, C

INTERNATIONAL SEARCH REPORT

Information on patent family members

Int. Application No

PCT/GB 98/00598

Patent document cited in search report	Publication date	Patent family member(s)	Publication date
WO 9510846 A	20-04-1995	HU 69281 A	28-09-1995
		AU 1074595 A	04-05-1995
EP 0545038 A	09-06-1993	CH 682858 A	30-11-1993
		AT 122496 T	15-05-1995
		AU 655083 B	01-12-1994
		AU 2811692 A	10-06-1993
		CA 2081442 A	05-06-1993
		CZ 280827 B	17-04-1996
		DE 59202147 D	14-06-1995
		ES 2074319 T	01-09-1995
		PL 171837 B	30-06-1997
		US 5291366 A	01-03-1994
		EP 0726581 A	14-08-1996
AU 4338996 A	29-08-1996		
CA 2166909 A	12-08-1996		
CN 1136210 A	20-11-1996		
CZ 9600300 A	14-08-1996		
FI 960598 A	12-08-1996		
HR 960050 A	31-08-1997		
HU 73210 A	28-06-1996		
JP 8255526 A	01-10-1996		
PL 312710 A	19-08-1996		
SK 17096 A	05-02-1997		
US 5684664 A	04-11-1997		
US 4825188 A	25-04-1989		
		AU 1257388 A	08-09-1988
		CA 1310811 A	01-12-1992
		EP 0281945 A	14-09-1988
		JP 2647893 B	27-08-1997
		JP 63228701 A	22-09-1988