

F. H. C. MEY.  
Metallic Belting.

No. 203,476.

Patented May 7, 1878.

FIG. 1.

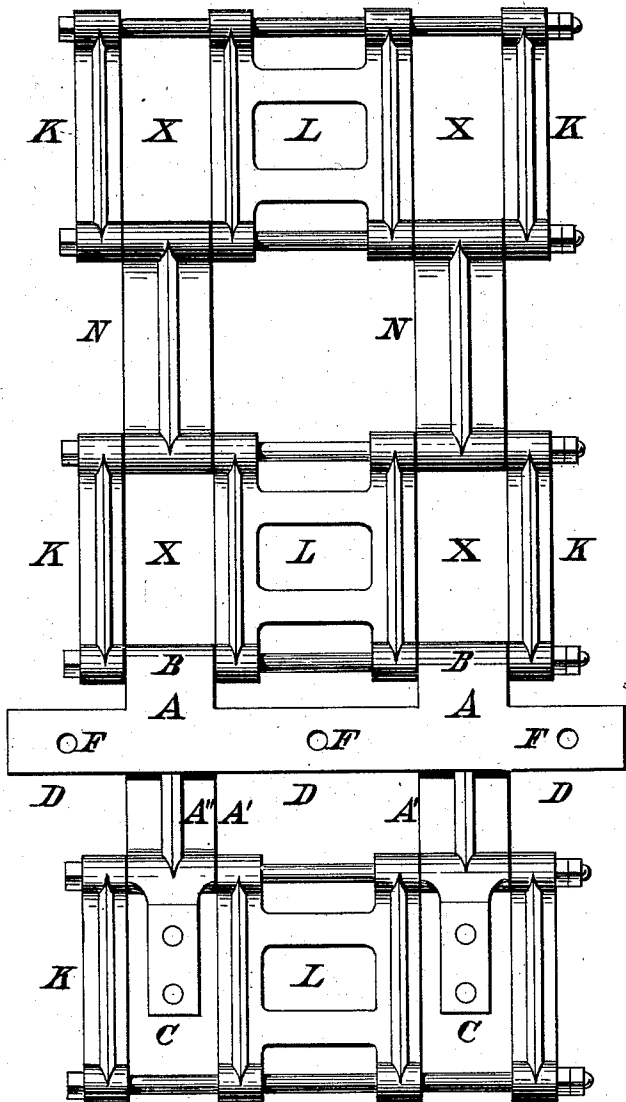
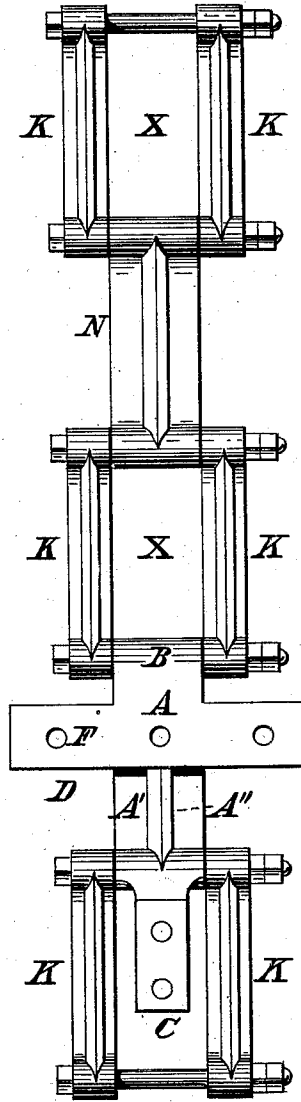

FIG. 2.



Witnesses:

*Frank Kirsch*  
*Chas. Bussart*

Inventor:

*Fred. H. C. Mey.*

F. H. C. MEY.  
Metallic Belting.

No. 203,476.

Patented May 7, 1878.

FIG. 3.

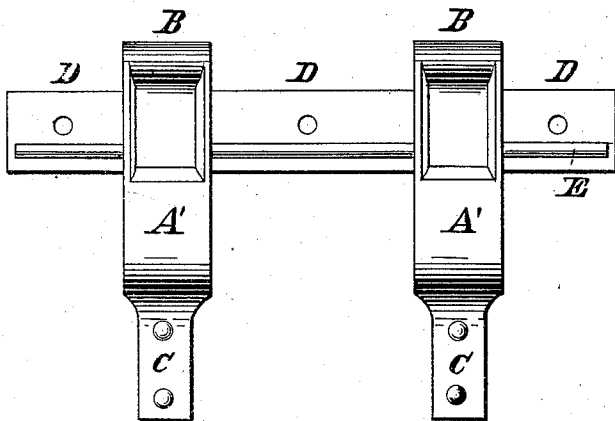
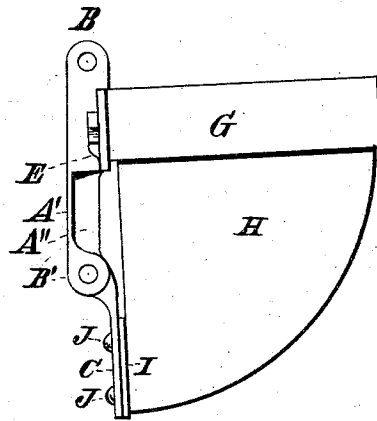

FIG. 4.



Witnesses:

Frank Hirsch.  
Chas. Besant.

Inventor:

Fred. H. C. Mey.

# UNITED STATES PATENT OFFICE.

FRED. H. C. MEY, OF BUFFALO, NEW YORK.

## IMPROVEMENT IN METALLIC BELTING.

Specification forming part of Letters Patent No. 203,476, dated May 7, 1878; application filed April 1, 1878.

*To all whom it may concern:*

Be it known that I, FRED. H. C. MEY, of Buffalo, in the county of Erie and State of New York, have invented certain new and useful Improvements on a Metallic Belting; and I do hereby declare that the following description of my said invention, taken in connection with the accompanying sheets of drawings, forms a full, clear, and exact specification, which will enable others skilled in the art to which it appertains to make and use the same.

This invention has special reference to metallic belting for elevating and conveying purposes; and it consists in the peculiar arrangement of parts and details of construction, as hereinafter first fully set forth and described, and then pointed out in the claims.

In the drawings heretofore mentioned, Figure 1 is a plan of a section of my improved belting composed of a double line of links. Fig. 2 is a like view of a single line of the same. Fig. 3 is rear, and Fig. 4 an edge, view of the bucket-link detached.

Like letters of reference indicate similar parts in all the figures.

A is the bucket-link. It consists of the flat plate A', having the central rib A'', and on both its extremities eyes B B', respectively, the latter eye terminating in a tail-piece, C. Below the upper eye B the plate A' is provided with a cross-bar, D, raised above the base-plate A' a distance corresponding to the diameter of the eyes B, the under side of which bar having longitudinally a rib, E. The cross-bar has perforations F, for the attachment of the elevator-bucket, hooks, &c., by means of bolts. The tail C is provided on its top side with a flexible cushion, I, made of leather, rubber, &c., and secured to said tail-piece C by rivets or similar means, J. The elevator-bucket H rests with its lower edge upon these cushions, and is thereby prevented from being abraded and speedily destroyed.

The bucket-link A connects, by means of two plain links, K, and one brace-link, L, with two broad plain links, N, which, in turn, are connected with the bucket-link A by two side links, K, and center brace-link L. In this manner a series of my belting is composed of the various links mentioned, and a belting

formed of as many series as are the required length. The sprockets on the driving-wheels engage the links in the openings X, and, pushing on the eyes of the links A and K, cause the belt to move when the said wheel rotates.

Elevator-beltings, in order to be efficient, should be extremely flexible, and to attain this result it is essential that the links should be as short as possible without interfering with the carrying capacity of the buckets. This latter prerequisite cannot, however, be attained together with the former unless such means are resorted to as shown in my bucket-link A. This link, as well as all the other connecting-links, is, in point of length between the centers of the pivot-eyes, extremely short; but, in order to facilitate the attachment of deeper buckets, I have provided said link A with the tail-piece or rest C, which carries the lower end of said bucket, and thereby sustains the same.

In order to reduce, or rather to avoid, friction and abrasion of the bucket, I have provided the tail-piece C with an elastic cushion, interposed between the tail-piece and bucket, and thus accomplished the desired result, besides avoiding the disagreeable noise caused by the buckets striking the links when in operation.

In belting requiring a greater width of buckets than the single-link bucket will allow, I shall construct the cross-bars D of the required length, and provide it with as many bodies A', having eyes and tail-pieces, as described, as are necessary to give the required strength to the belting, using as many lines of intermediate links as there are bodies A.

In Fig. 1 I have illustrated a double line of links, and have shown the bucket-link A made with two bodies and accessories. It is evident, however, that more lines may be used; and that, instead of using links A with the cross-bar formed in one piece with a plurality of bodies, a series of the link A (shown in Fig. 2) may be used in connection with a double, triple, &c., line of belting-links without changing the nature of my invention.

It is obvious that my belting may be used for all the various purposes of elevating, conveying, &c., by securing either buckets, scrapers, carriers, hooks, &c., to the cross-bar D in

a manner readily understood by any one acquainted with the various methods and means of conveying by an endless belt.

It will be observed that the under side of all my links are perfectly flat, there being no bolt-heads, &c., projecting over the base-line of the belting, the cross-bar D being raised above the base-line sufficiently to allow said heads being above said base-line, as shown in Fig. 4. In this manner I am enabled to place bearer or carrying planks under my belting to sustain the weight thereof, and thereby to materially increase the durability of my belt.

In elevator-belting requiring a larger number of buckets than the construction of the series affords, or to increase the capacity of a belt having the series of links, as described, I shall dispense with or take out the broak links N and substitute bucket-links A, thus doubling the number of bucket-links and the capacity of the belting.

All the links entering into the construction of my belting are produced entire and complete in the process of casting and subsequent annealing of malleable iron or cast-steel, the perforations in the eyes being produced by coring, and said eyes are therefore all solid, in contradistinction to those where the eyes are bent and not closed. By thus producing my belting it is capable of sustaining twice the strain of a belting of similar area made in the latter way; or my belting can be reduced in weight to nearly one-half without reducing it in strength below that of such belting.

As heretofore described, the cross-bar D has a projecting rib, E, on its under side. This rib serves to strengthen the said cross-bar, and at the same time acts as a stop for the bolt-

heads securing the bucket to said cross-bar, and prevents them from turning. This is a very essential feature in my belting, inasmuch as it obviates one of the greatest troubles in removing buckets from or securing them to a belting already in position where access cannot be had to the under side of the belt to hold the heads in screwing and unscrewing.

Having thus fully described my invention, I claim—

1. The combination, with a bucket-link, of an elastic cushion secured to said link, in the manner as and for the purpose specified.
2. A bucket-link having the cross-bar D provided with the projecting rib E, as and for the object stated.
3. An elevator-belt composed of links having a T-shaped body and solid eyes on both extremities, said links being produced entire in the process of casting, as and for the purpose specified.
4. A bucket-link consisting of the cross-bar D and one or more bodies, A', having the rib or ribs A'', said bodies A' being provided with solid eyes B B' and the cross-bar raised above the base-line, as specified.
5. The combination, with the bucket-link A, of the side links K, as stated, said links forming a repeating series in belting; as stated.

In testimony that I claim the foregoing as my invention I have hereto set my hand and affixed my seal in the presence of two subscribing witnesses.

F. H. C. MEY. [L. s.]

Attest:

MICHAEL J. STARK,  
FRANK HIRSCH.