

(19) World Intellectual Property Organization
International Bureau



(43) International Publication Date
6 June 2002 (06.06.2002)

PCT

(10) International Publication Number
WO 02/43943 A1

(51) International Patent Classification⁷: **B29C 47/50**,
45/54

(21) International Application Number: PCT/US01/31678

(22) International Filing Date: 9 October 2001 (09.10.2001)

(25) Filing Language: English

(26) Publication Language: English

(30) Priority Data:
09/724,342 28 November 2000 (28.11.2000) US

(71) Applicant: **GENERAL ELECTRIC COMPANY**
[US/US]; 1 River Road, Schenectady, NY 12345 (US).

(72) Inventors: **ADEDEJI, Adeyinka**; 114 Hackett Boulevard,
Albany, NY 12209 (US). **HOSSAN, Robert**; 34 Yorkshire
Lane, Delmar, NY 12054-1328 (US). **PECAK, William,**
Eugene; 54 Western Avenue, Cohoes, NY 12047 (US).

(74) Agents: **HARRINGTON, Mark, F.** et al.; Harrington
& Smith, LLP, 1809 Black Rock Turnpike, Fairfield, CT
06432 (US).

(81) Designated States (*national*): AE, AG, AL, AM, AT, AU,
AZ, BA, BB, BG, BR, BY, BZ, CA, CH, CN, CO, CR, CU,
CZ, DE, DK, DM, DZ, EC, EE, ES, FI, GB, GD, GE, GH,
GM, HR, HU, ID, IL, IN, IS, JP, KE, KG, KP, KR, KZ, LC,
LK, LR, LS, LT, LU, LV, MA, MD, MG, MK, MN, MW,
MX, MZ, NO, NZ, PL, PT, RO, RU, SD, SE, SG, SI, SK,
SL, TJ, TM, TR, TT, TZ, UA, UG, UZ, VN, YU, ZA, ZW.

(84) Designated States (*regional*): ARIPO patent (GH, GM,
KE, LS, MW, MZ, SD, SL, SZ, TZ, UG, ZW), Eurasian
patent (AM, AZ, BY, KG, KZ, MD, RU, TJ, TM), European
patent (AT, BE, CH, CY, DE, DK, ES, FI, FR, GB, GR, IE,
IT, LU, MC, NL, PT, SE, TR), OAPI patent (BF, BJ, CF,
CG, CI, CM, GA, GN, GQ, GW, ML, MR, NE, SN, TD,
TG).

Published:

- with international search report
- before the expiration of the time limit for amending the
claims and to be republished in the event of receipt of
amendments

For two-letter codes and other abbreviations, refer to the "Guidance Notes on Codes and Abbreviations" appearing at the beginning of each regular issue of the PCT Gazette.

(54) Title: METHODS FOR MOLDING AND PROCESSING BLENDS WITH THERMOPLASTIC RESINS

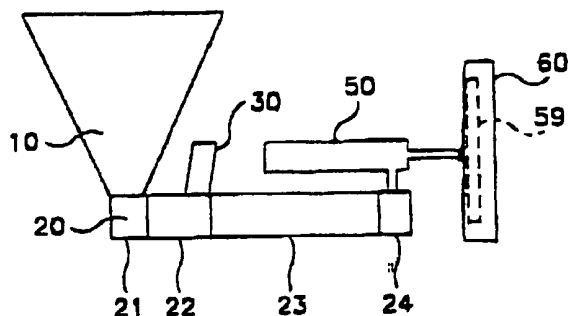

(57) Abstract: Methods are provided for molding polyphenylene ether resins and other thermoplastic resins directly from a power or pellets by compounding the powdered or pelletized thermoplastic resin with other blend components within an extruder (20) to form a homogeneous blend and feeding the homogeneous blend to an accumulator (50) where it is transferred to a cavity (59) of a mold (60). Methods for processing blends of polyphenylene ether resins and other thermoplastic resins alternatively into molded articles or extruded articles are provided where blends are formed in an extruder (200) and are alternatively fed into an accumulator (500) and transferred to a cavity (590) of a closed mold (600) or an extruder die (700) to form strands which are cooled and pelletized in pelletizer



WO 02/43943 A1
(800).

METHODS FOR MOLDING AND PROCESSING BLENDS WITH
THERMOPLASTIC RESINS

BACKGROUND OF THE INVENTION

FIELD OF THE INVENTION

5 This invention relates to a method for preparing and processing plastic blends which permits the direct molding of plastic blends into finished articles with reduced pre-compounding and solidifying the plastic blends into pellets.

BRIEF DESCRIPTION OF RELATED ART

10 Preparing molded plastic articles from blends containing thermoplastic resins is typically performed in multiple stages. In one stage, powders of the thermoplastic resin are melt-compounded in an extruder with other blend components, extruded, solidified and cut into pellets. In another stage, these pellets are remelted and molded into finished articles.

15 The manufacturers' cost for a molded plastic article is primarily the sum of the raw materials cost plus the conversion/processing cost (energy and equipment). Conversion/processing costs are often significant and can influence whether a high cost engineering thermoplastic resin can compete with a commodity resin.

20 The efficiency in eliminating the pellet forming steps and preparing articles directly after melt compounding has been recognized. For example, the extrusion of pipe and profile articles (extruded articles) directly after compounding of polyvinyl chloride powder is described in U.S. Patent Nos. 4,243,629 and 5,198,170. This can be accomplished with commercially
25 available direct extruders, such as the ZSK twin-screw extruder and ZSK-MEGA compounder sold by Werner and Pfleiderer. (See

www.kwpc.com/kwpc/markets/directex/directex(3,5,6 and _overview).html, 4/11/2000.) These direct extruders eliminate the pelletizing step by combining the compounding of raw materials with the extrusion of a homogeneous melt through a die in one machine.

5 Unlike direct extrusion, the molding of thermoplastic articles in a closed mold requires interruption of the feed. The molding cycle of filling the mold with thermoplastic resin, setting of the thermoplastic resin in the mold, opening of the mold, removing the solidified molded article and closing the mold requires that the extruder which feeds the mold remain idle for a
10 substantial amount of time.

It is desirable to provide a method which permits the direct molding of blends comprising thermoplastics within a closed mold from a thermoplastic powder which does not require a pellet forming step and preferably does not require a significant commitment of equipment (capital expense) in preparing
15 molded articles.

SUMMARY OF THE INVENTION

The present invention provides a method wherein powdered or pelletized thermoplastic resins are compounded with blend components within an extruder and directly molded in a closed mold to produce useful
20 articles under about 91 kg, preferably under about 45 kg, most preferably under about 36 kg, without a pellet forming step. This method comprises:

- a) feeding powdered or pelletized thermoplastic resin and one or more additional components into an extruder,
- b) melting at least the powdered thermoplastic resin within the
25 extruder,
- c) compounding the molten thermoplastic resin with the one or more

5 additional components within the extruder such as other thermoplastic resins, processing aids (blowing agents, plasticizers), additives (impact modifiers, flame retardants, antioxidants), fillers, pigments and reinforcing materials, to form a molten blend, preferably a homogeneous molten blend,

- d) feeding the molten blend from the extruder to one or more accumulation zones,
- e) transferring the molten blend from each accumulation zone to one or more cavities of one or more closed molds;
- 10 f) solidifying the homogeneous molten blend within each cavity of each closed mold to form a solid molded article; and
- g) recovering the solid molded article from each cavity of each closed mold.

The present invention also provides a method of processing blends
15 with thermoplastic resins wherein molded articles under 200 pounds (91 kg), pellets and profile articles can be prepared alternatively, subsequent to compounding, using the same extruder. This serves to reduce the commitment of equipment to direct molding and further reduces the conversion/processing cost. The molded articles are preferably under 100
20 pounds (45 kg), most preferably under 80 pounds (36 kg). This method of processing blends comprises:

- a) selecting an output for an extruder that forms end products selected from the group consisting of extrudates and molded articles;
- 25 b) feeding powdered or pelletized thermoplastic resin and one or

more additional components, as described above and below, into the extruder;

- c) melting at least the powdered thermoplastic resin within the extruder;
- 5 d) compounding the molten thermoplastic resin and the one or more additional components within said extruder to form a homogeneous molten blend;
- e) feeding the homogeneous molten blend to the selected output that forms the end-product selected;
- 10 f) solidifying the homogeneous molten blend fed to the selected output to form the selected end-product;
- g) recovering the solidified selected end-product from the selected output; and
- 15 h) changing the selected output of the extruder at least once to provide an end-product different from the selected end-product recovered in step g).

BRIEF DESCRIPTION OF THE DRAWINGS

20 Fig. 1 is a schematic representation of an apparatus which prepares molded articles directly from a powdered thermoplastic resin consistent with this invention.

Fig. 2 is a schematic representation of an apparatus which processes blends of thermoplastic resins consistent with the methods of this invention

shown preparing a molded article.

Fig. 3 is a schematic representation of the apparatus of Fig. 2 shown preparing pellets.

DETAILED DESCRIPTION OF THE INVENTION

5 The present invention provides a method for preparing molded articles in a closed mold directly from a powdered or pelletized thermoplastic resin. The molded article comprises a blend of thermoplastic resin and one or more additional components; such as other thermoplastic resins, additives (impact modifiers, antioxidants, flame retardants), processing aids (plasticizers, blowing agents), fillers, pigments and reinforcing agents. The method
10 comprises feeding powdered or pelletized thermoplastic resin and at least one additional component into an extruder, melting at least the powdered/pelletized thermoplastic resin within the extruder and compounding the molten thermoplastic resin with the one or more additional
15 components within the extruder to form a homogeneous molten blend. This homogeneous molten blend is fed to one or more accumulation zones which transfer the homogeneous molten blend to at least one mold cavity. The homogeneous molten blend is solidified within each mold cavity to form a solid molded article which is recovered from each mold cavity. A preferred
20 method produces articles, e.g., pellets, and employs an engineering thermoplastic resin such as polycarbonate resins, polyethylene terephthalate resins, polybutylene terephthalate resins, ABS resins, ASA resins, polysulfone resins, polyphenylene ether resins, polyarylene sulfide resins, polyetherimide resins, polyamide resins and blends and copolymers thereof.

25 Also provided by this invention is a more general method for processing blends within an extruder and preparing molded articles or extruded end products therefrom. The blends comprise a powdered or pelletized thermoplastic resin and at least one additional component, such as

other thermoplastic resins, processing aids (blowing agents, plasticizers), additives (impact modifiers, flame retardants, antioxidants) fillers, reinforcing agents and/or pigments. This method comprises selecting an output for an extruder from those that form molded articles as end-products and those that
5 form extruded end-products. A thermoplastic resin, powdered or pelletized, and at least one additional component are fed into this extruder. The powdered or pelletized thermoplastic resin is melted and compounded with the one or more additional components discussed above and below within the extruder to form a homogenous molten blend. This homogenous molten
10 blend is fed to the selected output of the extruder to form either a molded article end-product or an extruded end-product. The selected end-product is solidified and recovered. The method includes the additional step of changing the selected output of the extruder to produce an end-product different from that last recovered.

15 The methods of the present invention provide articles formed within a closed mold directly from a powdered or pelletized thermoplastic resin. The homogeneous blend does not have to be solidified and pelletized for subsequent molding procedures. The molded articles preferably are of a size less than 200 lbs. (91 kg), more preferably of a size less than 100 lbs. (45 kg)
20 and are most preferably are of the size within the range of 1-80 lbs. (.5-36 kg). Providing larger parts is more advantageous in that the efficiency gained from the method of the present invention is more pronounced when producing larger parts. The methods of the present invention provide particular advantage in molding parts in markets with small profit margins
25 such as, e.g., pallets.

The methods of the present invention can employ: 1) a powdered thermoplastic resin having on average no dimensions equal to or greater than 2mm, 2) a pelletized thermoplastic resin having on average at least one dimension greater than 2mm, or 3) both a powdered and pelletized

thermoplastic resin as in 1) and 2). Generally, any thermoplastic resin suitable for injection molding or blow molding is suitable. The process of the present invention is well suited for powdered engineering thermoplastic resins. Since the cost of processing such resins is typically higher than commodity resins, the advantages obtained in using powdered engineering thermoplastics are greater than when employing commodity thermoplastics. Engineering thermoplastics, as defined herein, include those having a heat distortion temperature greater than 150°F (65°C), a modulus of over 200 KPSI and notched IZOD values greater than 1 ft. lbs./in. Typically, the melt processing temperature (melt temperature), the greater the savings in molding the thermoplastic resin directly after compounding. Examples of suitable engineering thermoplastics include, polycarbonate resins, polyethylene terephthalate resins, polybutylene terephthalate resins, ABS resins, ASA resins, polysulfone resins, polyphenylene ether resins, polyarylene sulfide resins, polyetherimide resins, and polyamide resins and copolymers thereof.

Particularly preferred engineering thermoplastic resins are polyphenylene ether resins which are known polymers comprising a plurality of aryloxy repeating units, preferably with repeating units of Formula 1:

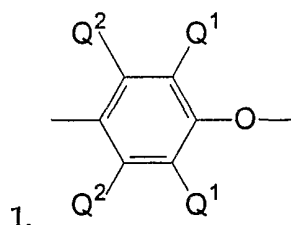

where, in each of said units independently, each Q¹ is independently halogen, alkyl (preferably primary or secondary lower alkyl containing up to 7 carbon atoms), aryl (preferably phenyl), halohydrocarbon groups (preferably haloalkyl) having at least two carbons between the halogen atoms and the phenyl nucleus of Formula I, aminoalkyl, hydrocarboxy or halohydrocarboxy wherein at least two carbon atoms separate the halogen

and oxygen atoms and at least two carbon atoms separate the halogen atoms and the phenyl nucleus of Formula I;

Each Q² is independently hydrogen, halogen, alkyl (preferably primary or secondary lower alkyl up to 7 carbon atoms), aryl (preferably phenyl),
5 halohydrocarbon (preferably haloalkyl) having at least two carbon atoms between the halogen atoms and the phenyl nucleus of Formula I, hydrocarboxy groups or halohydrocarboxy groups wherein at least two carbon atoms separate the halogen atoms from the phenyl nucleus of Formula I. Q¹ and Q² suitably contain up to about 12 carbon atoms and most often,
10 each Q¹ and Q² suitably contain up to about 12 carbon atoms and most often, each Q¹ is an alkyl or phenyl, especially C₁-C₄ alkyl and each Q² is hydrogen.

It should be recognized that the polyphenylene ether polymers contemplated for use in the present invention include all those presently known, irrespective of the variations in the structural units above or
15 deviations from the structure above.

Specific polyphenylene polymers useful in the methods of the present invention include, but are not limited to

poly(2,6-dimethyl-1,4-phenylene ether);

poly(2,3,6-trimethyl-1,4-phenylene) ether;

20 poly(2,6-diethyl-1,4-phenylene) ether;

poly(2-methyl-6-propyl-1,4-phenylene) ether;

poly(2,6-dipropyl-1,4-phenylene) ether;

poly(2-ethyl-6-propyl-1,4-phenylene) ether;

poly(2,6-dilauryl-1,4-phenylene) ether;

- poly(2,6-diphenyl-1,4-phenylene) ether;
- poly(2,6-dimethoxy-1,4-phenylene) ether;
- poly(2,6-diethoxy-1,4-phenylene) ether;
- poly(2-methoxy-6-ethoxy-1,4-phenylene) ether;
- 5 poly(2-ethyl-6-stearyloxy-1,4-phenylene) ether;
- poly(2,6-dichloro-1,4-phenylene) ether;
- poly(2-methyl-6-phenyl-1,4-phenylene) ether;
- poly(2-ethoxy-1,4-phenylene) ether;
- poly(2-chloro-1,4-phenylene) ether;
- 10 poly(2,6-dibromo-1,4-phenylene) ether;
- poly(3-bromo-2,6-dimethyl-1,4-phenylene) ether; mixtures thereof, and the like.

In preparing thermoplastic blends using the methods of the present invention, polyphenylene resin can be employed in an amount of from about 15 5-95% by weight of total composition, with the additional components making up the difference.

The blends containing thermoplastic resins prepared by the methods of the present invention contain one additional component other than the thermoplastic resin. The additional component can comprise another 20 thermoplastic resin. For example, in the case of blends containing polyphenylene ether resins, the following resins may be blended therewith:

vinyl aromatic resins, polyamides as disclosed in U.S. Patent Nos. 5,981,656 and 5,859,130, polyarylene sulfides as disclosed in U.S. Patent No.

5,290,881, polyphthalamides as disclosed in U.S. Patent No. 5,916,970, polyether amides as disclosed in U.S. Patent No. 5,231,146 and polyesters as disclosed in U.S. Patent No. 5,237,005.

The vinyl aromatic resins that may be added to the polyphenylene resins contain at least 25% by weight of structural units derived from monomers of the formula:

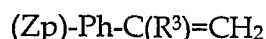

where Ph is phenyl, R³ is hydrogen, lower alkyl or halogen, Z is vinyl, halogen or lower alkyl p is 0-5. The vinyl aromatic polymers include homopolystyrene, polychlorostyrene, polyvinyltoluene and rubber modified polystyrene, sometimes referred to as "HIPS". Styrene-containing copolymers such as styrene-arylonitrile copolymers (SAN), styrene-maleic anhydride copolymers, polyalpha-methylstyrene and copolymers of ethylvinylbenzene and divinyl benzene are also suitable.

The additional component that is added to the blend of thermoplastic resin may be an impact modifier, flame retardant, plasticizer, antioxidant, filler, conductive filler (e.g. conductive carbon black, carbon fibers, stainless steel fibers, metal flakes, metal powders and the like); reinforcing agent, (e.g. of glass fibers), stabilizer (e.g. oxidative, thermal and ultraviolet stabilizers), antistatic agent, lubricant, colorant, dye, pigment, drip retardant, flow modifier, blowing agent or other processing aid.

A suitable impact modifying material for polyphenylene ether resins includes natural rubbers, synthetic rubbers and thermoplastic elastomers. These additives are typically derived from monomers such as olefins and may be homopolymers as well as copolymers including random, block, graft and core shell copolymers.

Polyolefins which can be blended with polyphenylene ether resins by

the methods of this invention are of the general structure C_nH_{2n} and include polyethylene, polypropylene and polyisobutylene with preferred homopolymers being polyethylene, LLDPE (linear low density polyethylene), HDPE (high density polyethylene), MDPE (medium density polyethylene) and isotactic polypropylene. Specific examples of polyolefin resins suitable for use in the present invention are defined in U.S. Patent No. 2,933,480, 3,093,621, 3,211,709, 3,646,186, 3,790,519, 3,884,993, 3,894,999, 4,059,654, 4,166,055 and 4,584,334.

Other suitable materials for impact modification include conjugated diene homopolymers and random copolymers. Examples include polybutadiene, butadiene-styrene copolymers, butadiene-acrylate copolymers, isoprene-isobutene copolymers, chlorine butadiene polymers, butadiene acrylonitrile polymers and polyisoprene. The impact modifiers may comprise of 0 to 30 wt% of the total composition. Copolymers of ethylene, C_3 - C_{10} monoolefins and non-conjugated dienes. Such as ethylene propylene diene modified rubbers (EPDM) are used in smaller amounts of from about 0.1% to 10% by weight based on the weight of the total composition. This amount generally falls within the range of 0.25% to about 7% by weight of the composition.

A particularly useful class of impact modifiers with conjugated dienes comprises the AB (di-block), $(AB)_m$ -R (di-block) and ABA' (tri-block) block copolymers. Blocks A and A' are typically alkenyl aromatic units and Block B is typically a conjugated diene unit. For block copolymers of the formula $(AB)_m$ -R, integer m is at least 2 and R is a multifunctional coupling agent for the blocks of the structure AB.

Also useful are core/shell graft copolymers of alkenyl aromatic and conjugated diene compounds. Especially suitable are those comprising styrene blocks and butadiene, isoprene or ethylene-butylene blocks. Suitable

conjugated diene blocks include the homopolymers and copolymers described above which may be partially or entirely hydrogenated by known methods, whereupon they may be represented as ethylene-propylene blocks or the like and have properties similar to those of olefin block copolymers.

5 The suitable alkenyl aromatics include styrene, alpha-methyl styrene, para-methyl styrene, vinyl toluene, vinyl xylene and vinyl naphthalene. The block copolymer preferably contains from about 15 to 80% alkenyl aromatic units. Examples of triblock copolymers of this type are polystyrene-polybutadiene-
10 polystyrene (SBS), hydrogenated polystyrene-polybutadiene-polystyrene (SEBS), polystyrene-polyisoprene-polystyrene (SIS) and poly(alpha-methylstyrene)-polyisoprene-poly(alpha-methylstyrene). Examples of commercially available triblock copolymers are the CARIFLEX[®], KRATON
D[®] and KRATON[®] G series from Shell Chemical Company, and Tuftec from Asahi Chemical Industry Co. Ltd.

15 Other additives which may be introduced into the blends of thermoplastic resin prepared by the methods of the claimed invention include flame retardants known in the art including halosubstituted diaromatic compounds as described in U.S. Patent 5,461,096 and phosphorous
20 compounds as described in U.S. Patent No. 5,461,096. Other examples of halosubstituted aromatic flame retardant additives include brominated benzene, chlorinated biphenyl, brominated polystyrene, chlorine containing aromatic polycarbonates or compounds comprising two phenyl radicals separated by a divalent alkenyl group having at least two chlorine or two
25 bromine atoms per phenyl nucleus, and mixtures thereof. The level of flame retardant can range 0.5 to 30 wt%.

Reinforcing agents such as glass fibers can be used and are preferably employed in an amount of from 0 to 60% by weight of the total composition. Preferred amounts range from 3 to 30% weight. Other suitable reinforcing fibers include carbon fibers, KEVLAR[®] fibers, carbon fibrils, stainless steel

fibers and metal coated graphite fibers. Suitable non-fibrous inorganic fillers include mica, clay, glass beads, glass flakes, graphite, aluminum hydrate, calcium carbonate, silica, kaolin, barium sulfate, talcum and calcium silicate (Wollastonite). Effective amounts for these fillers range from about 0.25 to 60 wt%.

Pigments may also be introduced into the blends of thermoplastic resin and include those conventionally known such as titanium dioxide and carbon black. Suitable stabilizers include zinc sulfide, zinc oxide and magnesium oxide. Suitable UV stabilizers include 4,6-dibenzyl resorcinols, alkanol amine morpholenes and benzotriazole. Suitable antioxidants include hydroxyl amines, hindered phenols, benzofuranones, hindered amines, aryl phosphites and alkyl phosphites and are preferably used in an amount of 0.1 to 1.5 wt%.

Suitable flow promoters and plasticizers include the phosphate plasticizers such as cresyl-diphenylphosphate, triphenyl phosphate, tricresyl phosphate, isopropylated and triphenyl phosphate. Chlorinated biphenols and mineral oil are also suitable. When used, the amount of plasticizer typically falls within the range of about 1 to 10 wt% based on the weight of the total composition.

Blowing agents may also be introduced into the blend of thermoplastic resin. Suitable blowing agents are those conventionally known in the art such as low boiling halohydrocarbons and those that generate carbon dioxide. Other blowing agents suitable for use in this invention are solid at room temperature and when heated to temperatures higher than their decomposition temperature, they generate gases such as nitrogen, carbon dioxide, ammonia gas, etc. These include azodicarbonamide, metal salts of azodicarbonamide, 4,4'-oxybis(benzenesulfonylhydrazide), sodium bicarbonate, ammonium carbonate, etc. The amount used typically is in the range of 0.1 to 20 parts by weight per 100 parts by weight of the thermoplastic

resin.

The methods of the present invention are performed in an extruder which preferably has a section that provides "compounding" or "distributive mixing" so as to disperse the components of the blend. The extruder can be a
5 single screw extruder but most preferably is a twin screw extruder to provide high shear within a short cycle time. The components of the thermoplastic blend can be fed into the extruder in a conventional manner. The thermoplastic powders/pellets are fed at the upstream end of the extruder using a conventional feed hopper and the one or more additional components
10 can either be fed in the same feed hopper or a separate port located downstream, preferably after the thermoplastic resin powders/pellets have melted. The thermoplastic powders /pellets may be mixed with other components prior to feeding into the extruder but are preferably powdered products obtained after synthesis in solution and isolated therefrom. The
15 additional component can be a liquid or a solid (powder or pellet).

A preferred extruder is one referred to as a "direct extruder" sold by Werner and Pfleiderer. These include the ZSK twin extruder and the ZSK 40 and ZSK 50 MEGA compounders used to extrude profile articles. These
20 extruders permit the addition of filler or other additives with the powdered/pelletized thermoplastic resin or at an intake port after the melt, downstream of the melting section, preferably where the extruders are vented to remove air and moisture entrained in the additives and thermoplastic resins. Single screw direct extruders which provide the desired compounding are also suitable. In the preferred embodiments, a vacuum is applied to
25 devolatilize the thermoplastic resins and additives.

The powdered thermoplastic resin typically is obtained from a suspension polymerization or other solution polymerization technique wherein the polymer precipitates when a certain molecular weight is

achieved or a non-solvent is added to the solution. The powders typically range in size from about 60 microns and above preferably from about 70 to 100 microns. For polyphenylene ethers, the viscosity typically ranges from 0.08 to 0.6 dl/g as measured in chloroform at 25°C.

5 The additional component added to the thermoplastic resin can range from about 0.01 to about 500 parts by weight per 100 parts of the thermoplastic resin. These can include other thermoplastic resins, processing aids, fillers, pigments and reinforcing materials as discussed above.

10 To form the homogeneous molten blend, the thermoplastic resin must be melted within the extruder. The barrel of the extruder is typically divided into a plurality of heating zones which are heated to a temperature above the melting or flow point of the thermoplastic resin. Sections of the extruder can be heated or cooled as is necessary. The heated walls and internal friction heat cause the thermoplastic resin to change from a solid to a molten state.
15 One or two screws within the barrel are turned to mix and move the thermoplastic resin through a feed zone, a melting zone, a mixing zone and an outlet.

 The molten thermoplastic resin is compounded with the additive components by mixing under compression and high shear. The nature of the
20 compounding, i.e. the level of shear and pressure applied to the molten thermoplastic resin and additive components by the extruder can be varied and controlled through the length and width of the extruder barrel, the length and diameter of the screw, the number of flights in the screw, the pitch of the flights in the screw, the speed of the screw and the residence time of the
25 molten thermoplastic resin and additive components within the extruder.

 Where an additive component has a melting point comparable to the thermoplastic resin, both the thermoplastic resin and additive component can be melted together for easier compounding.

The homogeneous molten blend is fed to an output of the extruder. This can be one or more accumulation zones for transferring the homogeneous molten blend to a closed mold or an extrusion die which forms continuous strands or profile articles such as a U channel, J channel, pipe, etc.

5 In the methods for preparing molded articles provided by this invention, the output of the extruder is one or more accumulation zones for transferring the homogeneous molten blend to one or more mold cavities. The homogeneous molten blend is solidified within each mold cavity to form a solid molded article. The solid molded article is then recovered from the
10 mold cavity. Recovery can be accomplished by conventional techniques employing conventional recovery equipment where necessary.

In the general methods for processing blends with thermoplastic resins provided by this invention, two types of outputs for the extruder can be selected and the output is required to be switched at least once. The two
15 outputs are one or more accumulation zones and an extrusion die as described above. Where the homogeneous molten blend is to be compounded further to add colorants, reinforcements or other additives, it is extruded through a die, cooled and pelletized with a conventional pelletizer.

Where the homogeneous molten blend is fed into one or more
20 accumulation zones, the homogeneous molten blend is transferred into a closed mold once there is sufficient material within the accumulation zone to fill the mold or provide a suitable charge when filling the mold. Two accumulation zones may be employed to feed different ports of a mold or different molds. The use of two or more accumulation zones allows one to fill
25 while the other transfers some of homogeneous molten blend into a mold. This allows the extruder to run continuously. The accumulation zone can transfer the homogeneous molten blend to an injection molding machine to aid transfer to a mold, such as a Van Dorn DeMag injection molding machine

or to a blow molding machine to aid transfer to a mold. Multiple mold cavities may also be used.

In the general methods of this invention, the output of the extruder is changed at least once, from the extruder die to an accumulation zone or from an accumulation zone to an extruder die to make a different end-product.

Experimental

An apparatus which performs a method of preparing molded articles provided by this invention is illustrated in Fig.1. Thermoplastic resin is fed into hopper 10 which feeds a single screw compounding extruder 20 in feed section 21. The thermoplastic resin is melted within extruder 20 in melting zone 22 and any volatiles are vented from port 30, downstream of melting zone 22. An additional component is introduced to extruder 20 through port 30. The thermoplastic resin is compounded with the additional component to form a homogeneous molten blend in mixing zone 23 downstream of port 30 and is feed from extruder 20 through an outlet 24 downstream of mixing zone 23 to an accumulator 50 positioned on top of extruder 20. Accumulator 50 transfers the homogeneous molten blend to a cavity 59 of a closed mold 60. The homogeneous molten blend is solidified within the cavity 59 of closed mold 60 and recovered by conventional means.

Fig. 2 illustrates an apparatus which performs a general method for processing blends of thermoplastic resins provided by this invention. Hopper 100 feeds a thermoplastic resin to twin screw extruder 200 in feed section 210 and the thermoplastic resin is melted in melt zone 220 and any volatiles are removed through port 300. An additive component is introduced to extruder 200 through port 300. The thermoplastic resin and additive component are compounded in mixing zone 230 downstream from port 300 to form a homogeneous blend which exists extruder 200 through outlet 240 downstream of mixing zone 230 to an output selected from accumulator 500

and extruder die 700. Accumulator 500 is shown attached to extruder 200 which transfers the homogeneous molten blend to a cavity 590 of a closed mold 600. The homogeneous molten blend is solidified and recovered from this mold. After preparing the desired quantity of molded articles such as
5 pallets, extruder die 700 replaces accumulator 500 at outlet 240 as shown in Fig. 3. Operation of the extruder 200 now provides a strand 710 of homogeneous molten blend which is cooled and cut into lengths or pellets with a pelletizer 800. The lengths or pellets 750 are collected in bin 900.

10 The entire disclosure of all applications, patents and publications, cited above are hereby incorporated by reference.

The preceding examples can be repeated with similar success by substituting the generically or specifically described reactants and/or operating conditions of this invention for those used in the examples.

15 From the foregoing description, one skilled in the art can easily ascertain the essential characteristics of this invention, and without departing from the spirit and scope thereof, can make various changes and modifications of the invention to adapt it to various usages and conditions.

WHAT IS CLAIMED IS

- 1 A method for preparing a molded article of a size less than about 91 kg in a closed mold directly from a powdered or pelletized thermoplastic resin, said molded article comprising a blend of said thermoplastic resin and one or more additional components, said method comprising:
 - a) feeding powdered or pelletized thermoplastic resin and one or more additional components into an extruder,
 - b) melting at least the powdered or pelletized thermoplastic resin within the extruder,
 - c) compounding the molten thermoplastic resin with one or more additional components within said extruder to form a homogeneous molten blend,
 - d) feeding the homogeneous molten blend from said extruder to one or more accumulation zones,
 - e) transferring the homogeneous molten blend from each accumulation zone to one or more cavities of one or more closed molds;
 - f) solidifying the homogeneous molten blend within each mold cavity of each closed mold to form a solid molded article;
 - g) recovering the solid molded article from each cavity of each closed mold.

2. A method for preparing a pallet of a size less about 91 kg in a closed mold directly from a powdered or pelletized thermoplastic resin, said pallet comprising a blend of said thermoplastic resin and one or more additional components,

said method comprising

- a) feeding powdered or pelletized thermoplastic resin and one or more additional components into an extruder,
 - b) melting at least the powdered or pelletized thermoplastic resin within the extruder,
 - c) compounding the molten thermoplastic resin with said one or more additional components within said extruder to form a homogeneous molten blend,
 - d) feeding the homogeneous molten blend from said extruder to one or more accumulation zones,
 - e) transferring the homogeneous molten blend from each accumulation zone to one or more cavities of a closed mold for a pallet;
 - f) solidifying the homogeneous molten blend within each cavity within each closed mold to form a solid pallet;
 - g) recovering the solid pallet from each cavity within each closed mold.
3. A method as in claim 1 wherein one or more accumulation zones are positioned on top of the extruder.
 4. A method as in claim 1 wherein the thermoplastic resin is an engineering thermoplastic resin having a modulus of over 200 KPSI, a heat distortion temperature of over 150°F (65°C) and Notched IZOD values of over 1 ft lb/in.
 5. A method as in claim 3 wherein the engineering thermoplastic resin is selected from the group consisting of polycarbonate resins,

polyethylene terephthalate resins, polybutylene terephthalate resins, ABS resins, ASA resins, polysulfone resins, polyphenylene ether resins, polyarylene sulfide resins, polyetherimide resins, polyamide resins, copolymers thereof and blends thereof.

6. A method as in claim 1 wherein the extruder is a single screw extruder and
 - a) a powdered thermoplastic resin is fed into said extruder through a feed hopper in the feed section of said extruder,
 - b) the powdered thermoplastic resin is melted in a melting zone of said extruder,
 - c) one or more additional components is fed through a port downstream of said melting zone,
 - d) the molten thermoplastic resin and one or more additional components are compounded in a mixing zone downstream of said port to form a homogeneous molten blend and
 - e) the homogeneous molten blend is fed from said extruder to one or more accumulation zones through an outlet positioned downstream of mixing zone.
7. A method as in claim 1 wherein the extruder is a direct extruder.
8. A method as in claim 1, wherein the one or more of additional components are selected from the group consisting of thermoplastic resins, additives, fillers, reinforcements and pigments.
9. A method for preparing a molded article of a size within the range of about 453 g to about 36 kg in a closed mold directly from a powdered or pelletized polyphenylene ether resin, said molded article comprising

a blend of polyphenylene ether resin and one or more additional components, said method comprising:

- a) feeding powdered or pelletized polyphenylene ether resin and one or more additional components into an extruder,
 - b) melting the powdered or pelletized polyphenylene ether resin within the extruder,
 - c) compounding the molten polyphenylene ether resin with the one or more additional components within said extruder to form a homogeneous molten blend,
 - d) feeding the homogeneous molten blend from said extruder to one or more accumulation zones,
 - e) transferring the homogeneous molten blend from each accumulation zone to one or more cavities of one or more closed molds;
 - f) solidifying the homogeneous molten blend within each cavity of each closed mold to form a solid molded article; and
 - g) recovering the solid molded article from each cavity of each closed mold.
10. A method as in claim 9 wherein the one or more additional components is selected from the group consisting of additional thermoplastic resins, impact modifiers, blowing agents and UV stabilizers.
11. A method as in claim 10 wherein the additional thermoplastic resin is selected from the group consisting of vinyl aromatic resins, polyamides, polyarylene sulfides, polyetherimides and polyesters.

12. A method as in claim 11 wherein the vinyl aromatic resin is selected from the group consisting of homopolystyrenes, styrene copolymers and rubber modified polystyrenes.
13. A method as in claim 9 wherein the homogeneous molten blend is transferred from each accumulation zone to one or more cavities of one or more closed molds by a blow molding apparatus.
14. A method as in claim 9 wherein the homogeneous molten blend is transferred from each accumulation zone to one or more cavities of one or more closed molds by an injection molding machine.
15. A method for processing a blend comprising at least one thermoplastic resin within an extruder, said method comprising:
 - a) selecting an output for an extruder that forms an end-products selected from the group consisting of extruded articles and molded articles;
 - b) feeding powdered or pelletized thermoplastic resin and one or more additional components into said extruder;
 - c) melting at least the powdered or pelletized thermoplastic resin within said extruder;
 - d) compounding the molten thermoplastic resin and said one or more additional components within said extruder to form a homogeneous molten blend;
 - e) feeding the homogeneous molten blend from said extruder to the selected output that forms the end-product selected;

- f) solidifying the homogeneous molten blend fed to the selected output to form the selected end-product, and
- g) recovering the selected end-product from the selected output,

wherein the selected output of said extruder is changed at least once to provide an end-product different from the solidified selected end-product recovered in step g).

- 16. A method as in claim 15 wherein the extruded articles comprise pellets and profile articles and the molded articles comprise injection molded articles and blow molded articles.
- 17. A method as in claim 15 wherein the extruder output is selected from
 - a) an extruder die which forms strands of the homogeneous molten blend which are cooled and cut into lengths or pellets with a cutter or pelletizer; and
 - b) one or more accumulation zones which transfers the homogeneous molten blend to a cavity of a closed mold, where the homogeneous blend is solidified and recovered.
- 18. A method as in claim 15 wherein the output of said extruder is changed more than once.
- 19. A method as in claim 15 wherein the extruder is a single screw extruder and
 - a) the powdered or pelletized thermoplastic resin is fed into said extruder through a feed hopper in feed zone of said extruder,

- b) the powdered or pelletized thermoplastic resin is melted in a melting zone of said extruder downstream of the feed zone,
 - c) the one or more additional components are fed through a port downstream of said melting zone,
 - d) the molten thermoplastic resin and one or more additional components are compounded in a mixing zone downstream of said port to form a homogeneous molten blend, and
 - e) the homogeneous molten blend is fed from said extruder to a selected output through an outlet downstream of said mixing zone.
20. A method as in claim 15 wherein the extruder is a direct extruder.
21. A method as in claim 15 wherein the thermoplastic resin is selected from the group consisting of polycarbonate resins, polyethylene terephthalate resins, polybutylene terephthalate resins, ABS resins, ASA resins, polysulfone resins, polyphenylene ether resins, polyarylene sulfide resins, polyetherimide resins, polyamide resins, copolymers thereof and blends thereof.
22. A method as in claim 21 wherein the one or more additional components is selected from the group consisting of vinyl aromatic resins, impact modifiers, flame retardants, plasticizers, fillers, pigments, reinforcing agents, antioxidants, blowing agents and UV stabilizers.

23. A method as in claim 21 wherein the vinyl aromatic resins are selected from the group consisting of homopolystyrene, styrene copolymers and a rubber modified polystyrene.

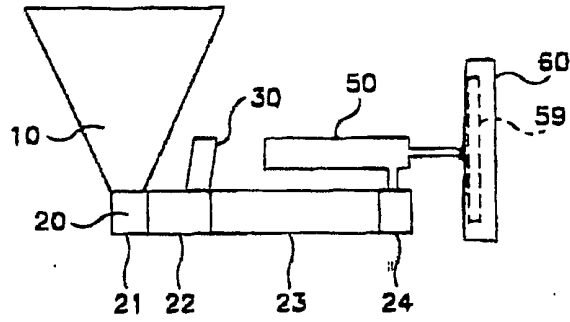

FIG. 1

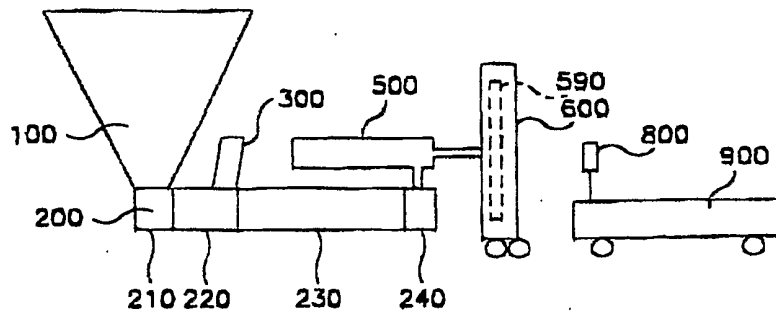

FIG. 2

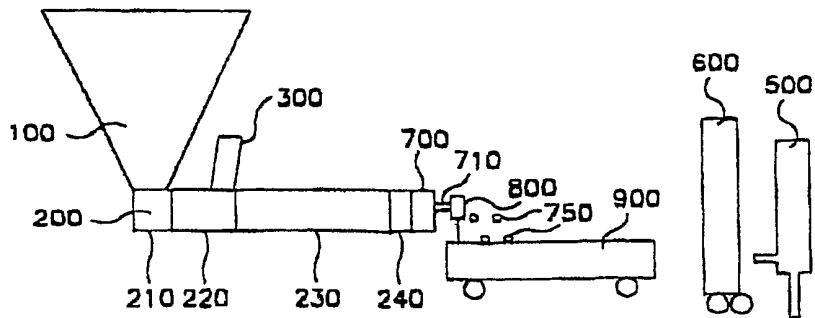

FIG. 3

INTERNATIONAL SEARCH REPORT

Int al Application No
PCT/US 01/31678

A. CLASSIFICATION OF SUBJECT MATTER
IPC 7 B29C47/50 B29C45/54

According to International Patent Classification (IPC) or to both national classification and IPC

B. FIELDS SEARCHED

Minimum documentation searched (classification system followed by classification symbols)

IPC 7 B29C

Documentation searched other than minimum documentation to the extent that such documents are included in the fields searched

Electronic data base consulted during the international search (name of data base and, where practical, search terms used)

WPI Data, EPO-Internal, PAJ

C. DOCUMENTS CONSIDERED TO BE RELEVANT

| Category ° | Citation of document, with indication, where appropriate, of the relevant passages | Relevant to claim No. |
|------------|--|-----------------------|
| X | US 5 424 020 A (MATUBARA SHIGEYOSHI ET AL) 13 June 1995 (1995-06-13) column 3, line 41 - line 54 column 4, line 21 - line 46 column 5, line 1 - line 15 claim 1; figures 5,7 | 1-23 |
| A | FR 1 412 075 A (VERLINDEN MARIUS A J) 24 September 1965 (1965-09-24) claims; figures 5-7 | 1-23 |
| A | PATENT ABSTRACTS OF JAPAN vol. 018, no. 173 (M-1581), 24 March 1994 (1994-03-24) & JP 05 337993 A (TOSHIBA MACH CO LTD), 21 December 1993 (1993-12-21) abstract | 1-23 |
| | --- -/-- | |

Further documents are listed in the continuation of box C.

Patent family members are listed in annex.

° Special categories of cited documents :

- *A* document defining the general state of the art which is not considered to be of particular relevance
- *E* earlier document but published on or after the international filing date
- *L* document which may throw doubts on priority claim(s) or which is cited to establish the publication date of another citation or other special reason (as specified)
- *O* document referring to an oral disclosure, use, exhibition or other means
- *P* document published prior to the international filing date but later than the priority date claimed

- *T* later document published after the international filing date or priority date and not in conflict with the application but cited to understand the principle or theory underlying the invention
- *X* document of particular relevance; the claimed invention cannot be considered novel or cannot be considered to involve an inventive step when the document is taken alone
- *Y* document of particular relevance; the claimed invention cannot be considered to involve an inventive step when the document is combined with one or more other such documents, such combination being obvious to a person skilled in the art.
- * & * document member of the same patent family

Date of the actual completion of the international search

25 March 2002

Date of mailing of the international search report

04/04/2002

Name and mailing address of the ISA

European Patent Office, P.B. 5818 Patentlaan 2
NL - 2280 HV Rijswijk
Tel. (+31-70) 340-2040, Tx. 31 651 epo nl,
Fax: (+31-70) 340-3016

Authorized officer

Jensen, K

INTERNATIONAL SEARCH REPORT

International Application No
PCT/US 01/31678

C.(Continuation) DOCUMENTS CONSIDERED TO BE RELEVANT

| Category * | Citation of document, with indication, where appropriate, of the relevant passages | Relevant to claim No. |
|------------|--|-----------------------|
| A | PATENT ABSTRACTS OF JAPAN vol. 017, no. 433 (M-1461), 11 August 1993 (1993-08-11) & JP 05 096587 A (TOKAI JIYUKEN KOGYO KK), 20 April 1993 (1993-04-20) abstract ----- | 1, 2, 9, 15 |

INTERNATIONAL SEARCH REPORT

Int. Application No

PCT/US 01/31678

Information on patent family members

| Patent document cited in search report | | Publication date | Patent family member(s) | Publication date |
|--|---|------------------|-------------------------|------------------|
| US 5424020 | A | 13-06-1995 | JP 2850392 B2 | 27-01-1999 |
| | | | JP 3076614 A | 02-04-1991 |
| | | | JP 2917372 B2 | 12-07-1999 |
| | | | JP 3261519 A | 21-11-1991 |
| | | | CA 2039160 A1 | 22-02-1991 |
| | | | DE 69021361 D1 | 07-09-1995 |
| | | | DE 69021361 T2 | 29-02-1996 |
| | | | EP 0439625 A1 | 07-08-1991 |
| | | | ES 2077684 T3 | 01-12-1995 |
| | | | WO 9102639 A1 | 07-03-1991 |
| | | | KR 181510 B1 | 15-05-1999 |
| | | | US 5275776 A | 04-01-1994 |
| | | | CA 2027741 A1 | 17-04-1991 |
| | | | EP 0423676 A2 | 24-04-1991 |
| FR 1412075 | A | 24-09-1965 | NONE | |
| JP 05337993 | A | 21-12-1993 | NONE | |
| JP 05096587 | A | 20-04-1993 | JP 1931933 C | 12-05-1995 |
| | | | JP 6051331 B | 06-07-1994 |