



US0D1064960S

(12) **United States Design Patent** (10) **Patent No.:** **US D1,064,960 S**
Tsarukyan (45) **Date of Patent:** **** Mar. 4, 2025**

(54) **REAR BUMPER FOR A VEHICLE**
(71) Applicant: **Bayerische Motoren Werke Aktiengesellschaft, Munich (DE)**
(72) Inventor: **Ernest Tsarukyan, Munich (DE)**
(73) Assignee: **Bayerische Motoren Werke Aktiengesellschaft, Munich (DE)**
(**) Term: **15 Years**

FOREIGN PATENT DOCUMENTS

WO WO DM/07 1066 6/2009
WO WO DM/228679 4/2023
WO WO DM/224518 10/2023

(21) Appl. No.: **29/912,937**
(22) Filed: **Sep. 26, 2023**
(30) **Foreign Application Priority Data**

OTHER PUBLICATIONS

2024 BMW SUVs_ What's New for X3, X5, XM, and More. Nov. 3, 2023. Motortrend. <https://www.motortrend.com/features/2024-bmw-suv-lineup-updates-changes/>.*

(Continued)

Primary Examiner — Garth Rademaker
Assistant Examiner — Suzanne E Tisdell
(74) *Attorney, Agent, or Firm* — Crowell & Moring LLP

Mar. 28, 2023 (DE) 402023100202.8
(51) **LOC (15) Cl.** **12-16**
(52) **U.S. Cl.**
USPC **D12/169**
(58) **Field of Classification Search**
USPC D12/86, 90, 91, 92, 98, 163, 164, 169, D12/190, 196
CPC B60R 19/02; B60R 19/04; B62D 25/08
See application file for complete search history.

CLAIM

The ornamental design for a rear bumper for a vehicle as shown and described.

(56) **References Cited**

DESCRIPTION

U.S. PATENT DOCUMENTS

This application contains subject matter related to the following co-pending U.S. design patent applications: application Ser. No. 29/890,386, filed Apr. 24, 2023 and entitled "Rear Bumper for a Vehicle"; application Ser. No. 29/858,133, filed Oct. 28, 2022 and entitled "Rear Bumper for a Vehicle"; application Ser. No. 29/912,934, filed herewith and entitled "Rear Bumper for a Vehicle"; and application Ser. No. 29/912,935, filed herewith and entitled "Rear Bumper for a Vehicle".

D610,499 S 2/2010 Truebsbach
D772,123 S 11/2016 Zurian
D824,301 S 7/2018 Lim
D856,210 S 8/2019 De Bono
D1,034,355 S * 7/2024 Mochizuki D12/169
D1,043,481 S * 9/2024 Yamashita D12/169
D1,044,627 S * 10/2024 Yamashita D12/169
D1,046,718 S * 10/2024 Yamashita D12/169
D1,046,719 S * 10/2024 Strunz D12/169
D1,050,982 S * 11/2024 Zurian D12/169

FIG. 1 is a front view of a rear bumper for a vehicle according to the design;
FIG. 2 is a left, bottom perspective view thereof;
FIG. 3 is a right, front perspective view thereof;
FIG. 4 is a left side view thereof;
FIG. 5 is a right side view thereof;
FIG. 6 is a top view thereof;
FIG. 7 is a bottom view thereof; and,
FIG. 8 is a rear view thereof.

(Continued)

1 Claim, 8 Drawing Sheets

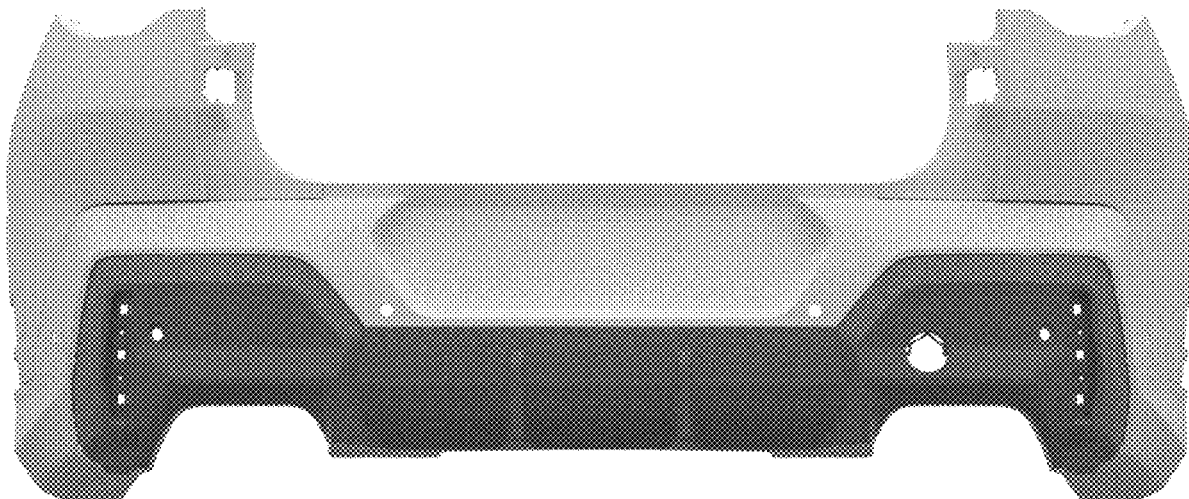

(56)

References Cited

U.S. PATENT DOCUMENTS

D1,051,792	S	*	11/2024	Roh	D12/169
D1,051,794	S	*	11/2024	Trpinac	D12/169
D1,052,482	S	*	11/2024	Piaskowski	D12/169
D1,053,088	S	*	12/2024	Shangguan	D12/169
D1,053,090	S	*	12/2024	Piaskowski	D12/169
D1,053,762	S	*	12/2024	Tanaka	D12/163
D1,053,763	S	*	12/2024	Powell	D12/169

OTHER PUBLICATIONS

2024 BMW X2 xDrive28i Review. Apr. 9, 2024. CarPro. <https://www.carpro.com/vehicle-reviews/2024-bmw-x2-xdrive28i>.*

My Favorite Features of the BMW X2, a Fun Entry-Level Luxury SUV. Nov. 15, 2024. Business Insider. <https://www.businessinsider.com/bmw-x2-xdrive28i-suv-review-favorite-safety-tech-luxury-features-2024-11>.*

* cited by examiner

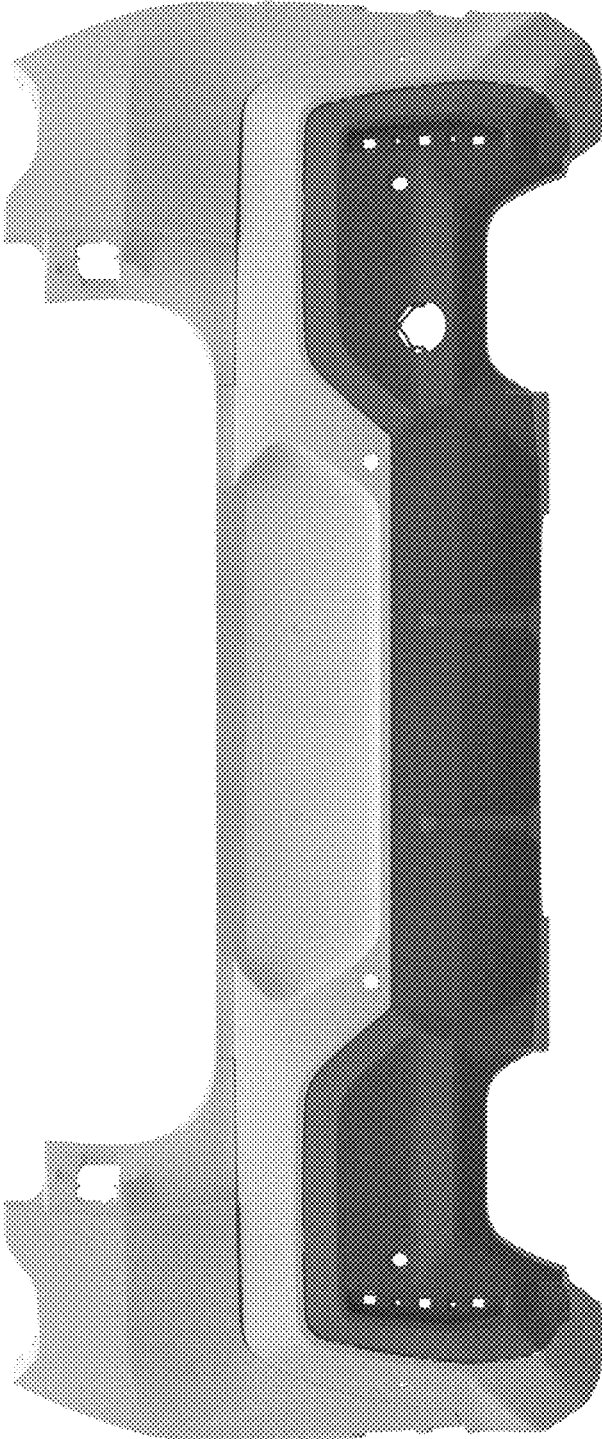

FIG. 1



FIG. 2

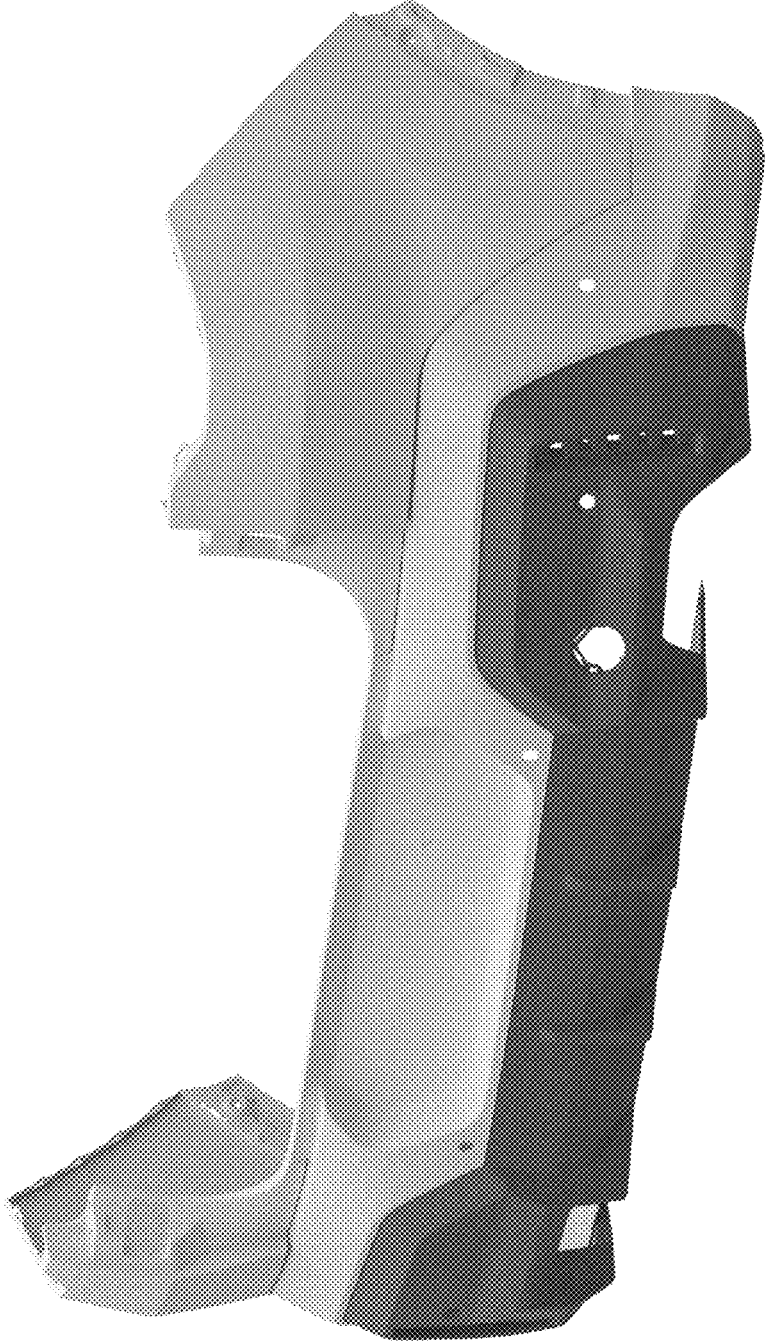

FIG. 3

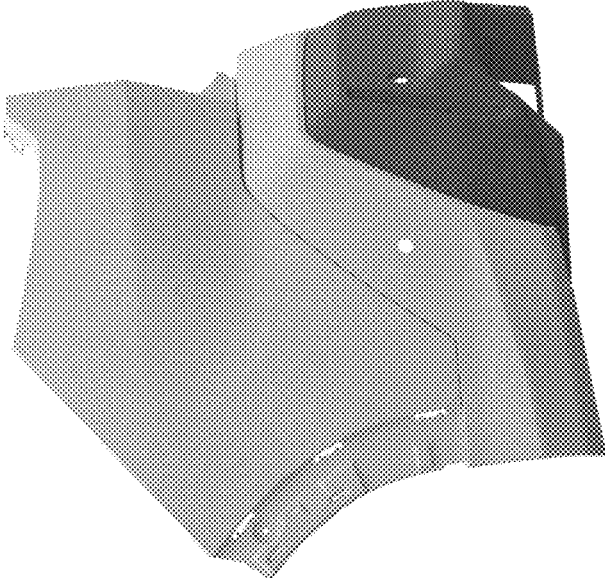

FIG. 4

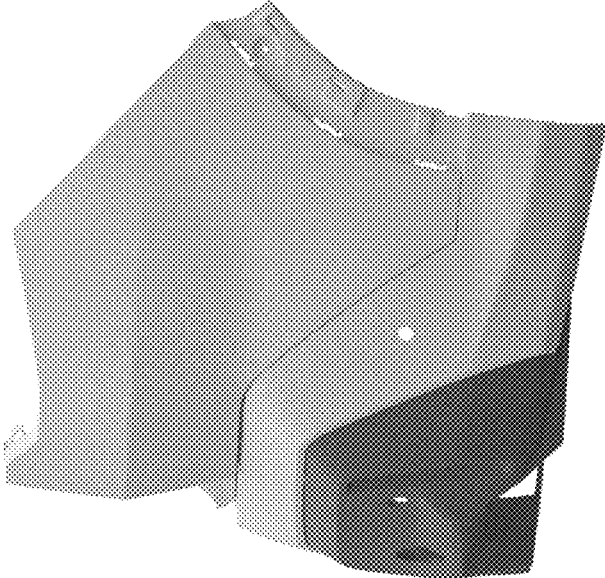

FIG. 5

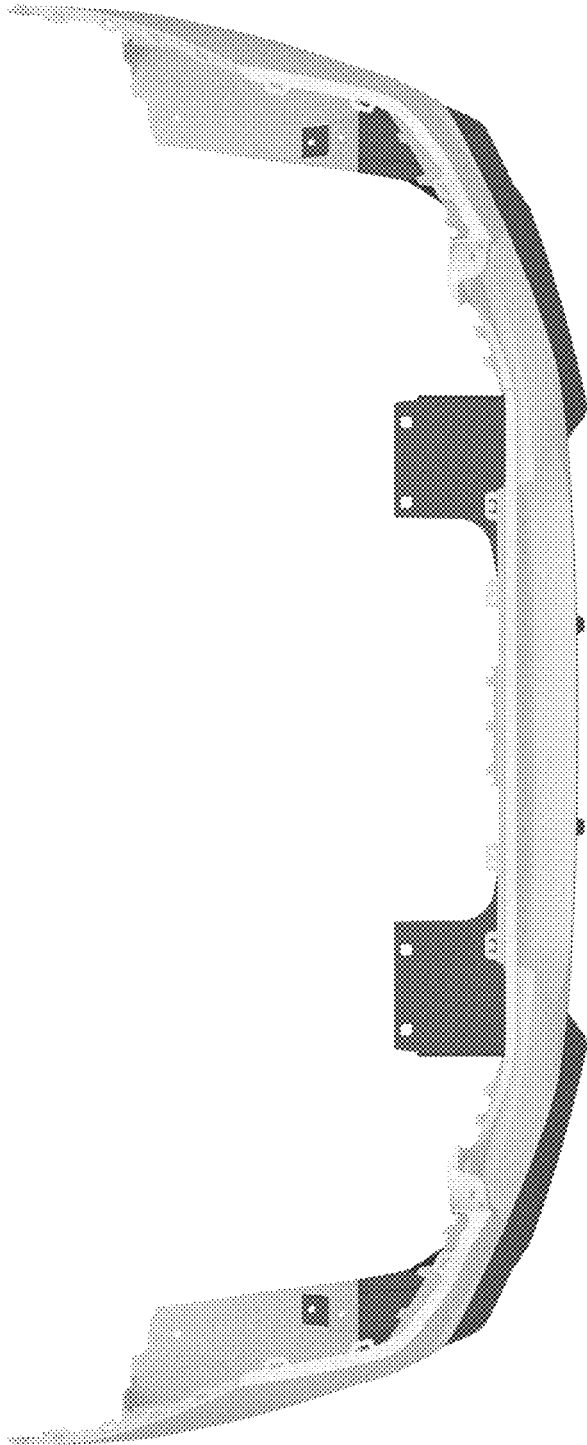

FIG. 6

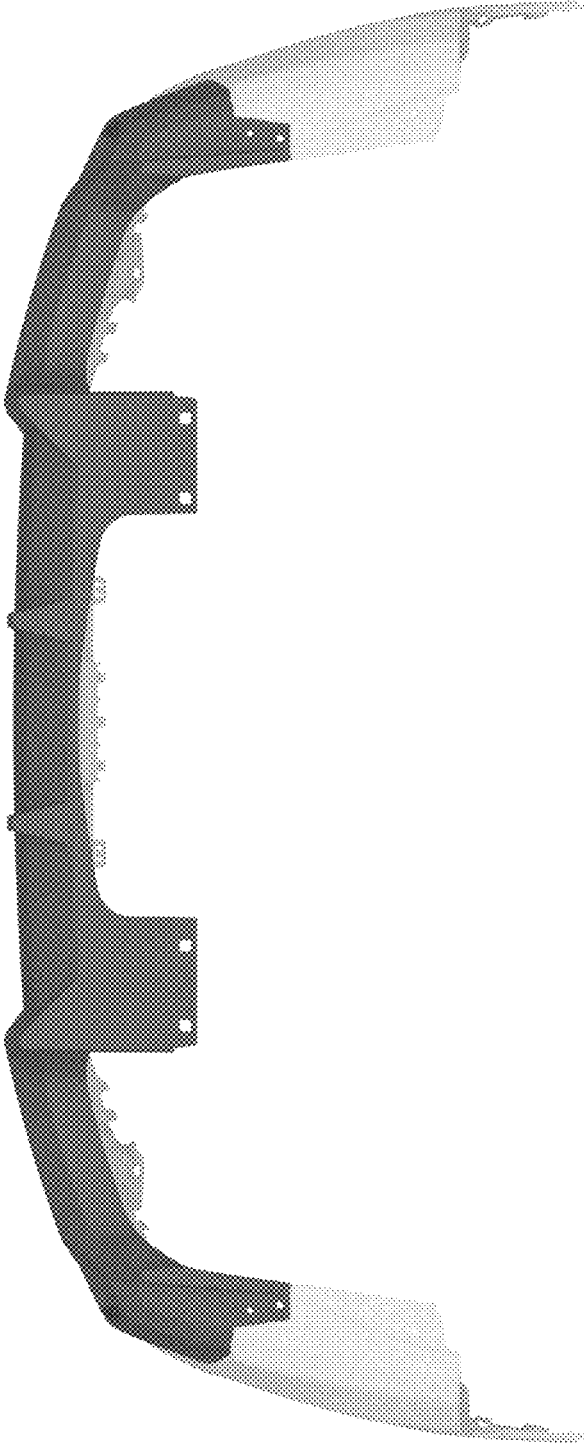

FIG. 7

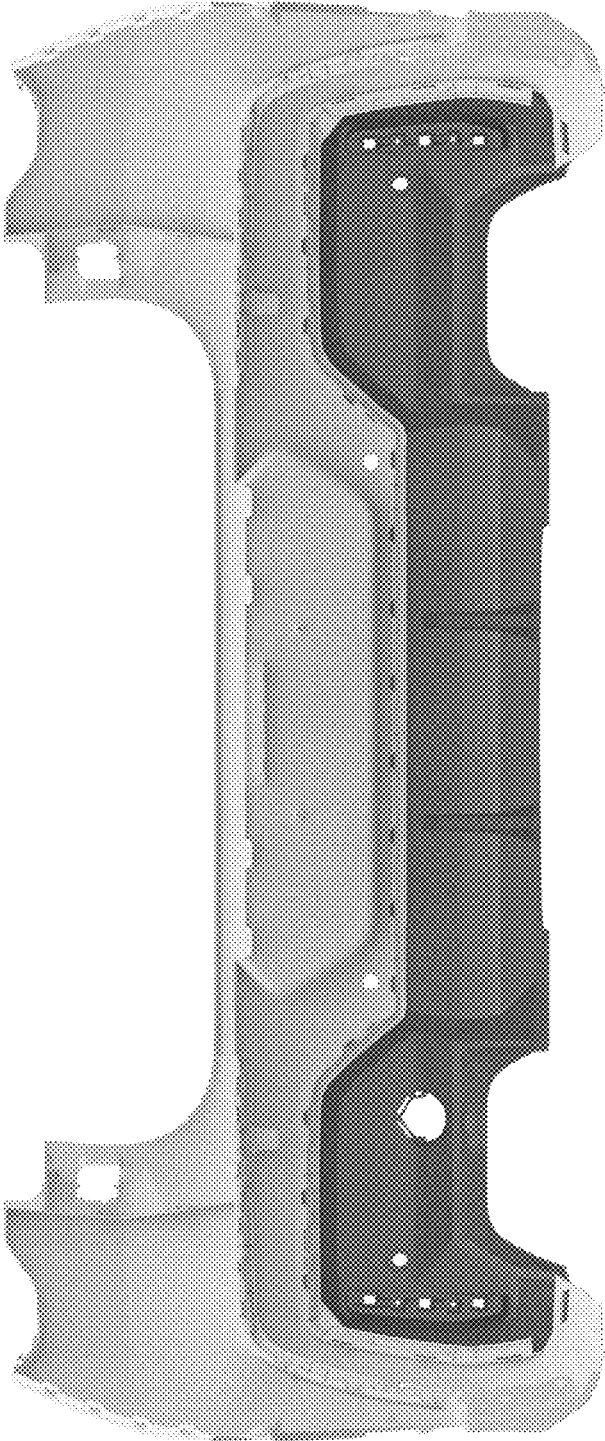

FIG. 8