



US 20190038897A1

(19) **United States**

(12) **Patent Application Publication**

Thakkar et al.

(10) **Pub. No.: US 2019/0038897 A1**

(43) **Pub. Date: Feb. 7, 2019**

(54) **SYSTEMS AND METHODS FOR INTRAVASCULAR CATHETER POSITIONING AND/OR NERVE STIMULATION**

A61B 5/00 (2006.01)
A61B 5/042 (2006.01)
A61B 5/0452 (2006.01)

(52) **U.S. Cl.**

CPC *A61N 1/3601* (2013.01); *A61N 1/0551* (2013.01); *A61B 5/0452* (2013.01); *A61B 5/0422* (2013.01); *A61B 5/4893* (2013.01)

(71) Applicant: **Lungpacer Medical Inc.**, Burnaby (CA)

(72) Inventors: **Viral S. Thakkar**, Burnaby (CA); **Douglas G. Evans**, Downingtown, PA (US); **Matthew J. Gani**, Seattle, WA (US)

(73) Assignee: **Lungpacer Medical Inc.**, Burnaby (CA)

(21) Appl. No.: **15/666,989**

(22) Filed: **Aug. 2, 2017**

Publication Classification

(51) **Int. Cl.**

A61N 1/36 (2006.01)
A61N 1/05 (2006.01)

(57) **ABSTRACT**

A method for positioning an intravascular catheter may include inserting the intravascular catheter into a venous system of a patient, wherein the catheter includes a plurality of electrodes, and multiple electrodes of the plurality of electrodes are configured to emit electrical signals; positioning a distal portion of the catheter in a first position; using one or more electrodes of the plurality of electrodes to acquire an ECG signal; based on the acquired ECG signal, adjusting the distal portion of the catheter to a second position different from the first position; identifying at least one first electrode of the plurality of electrodes to stimulate a first nerve; identifying at least one second electrode of the plurality of electrodes to stimulate a second nerve; and stimulating at least one of the first and second nerves to cause a contraction of a respiratory muscle.

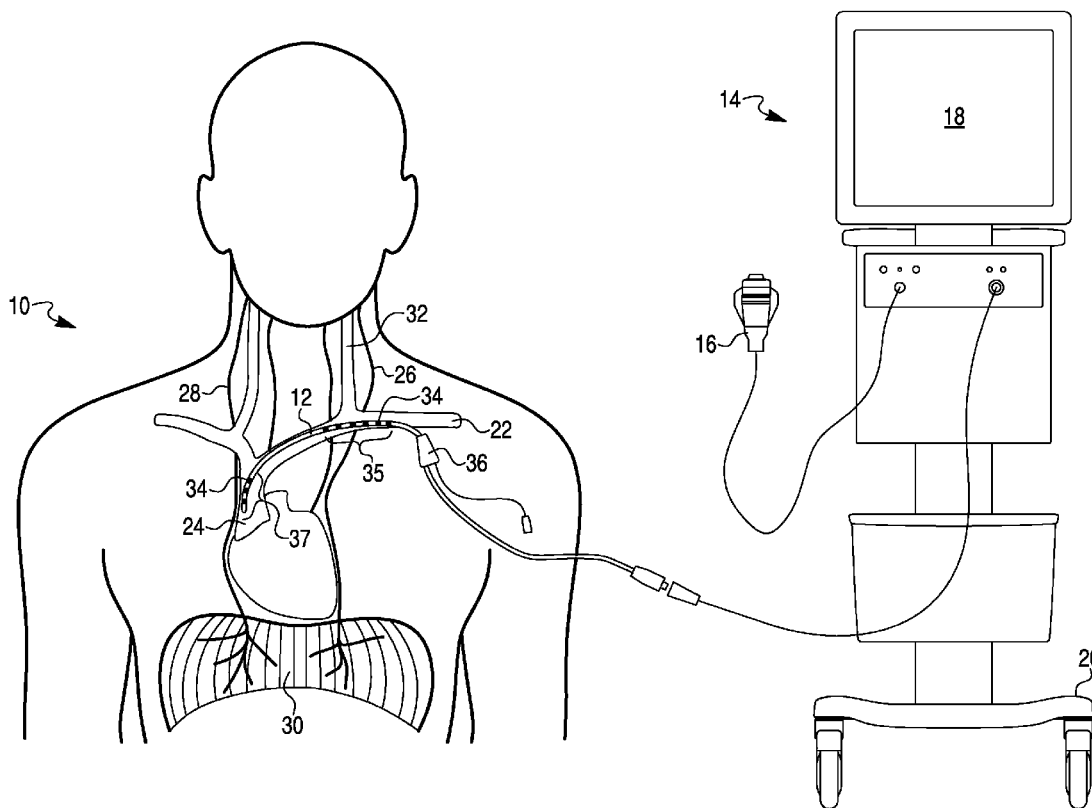

FIG. 2

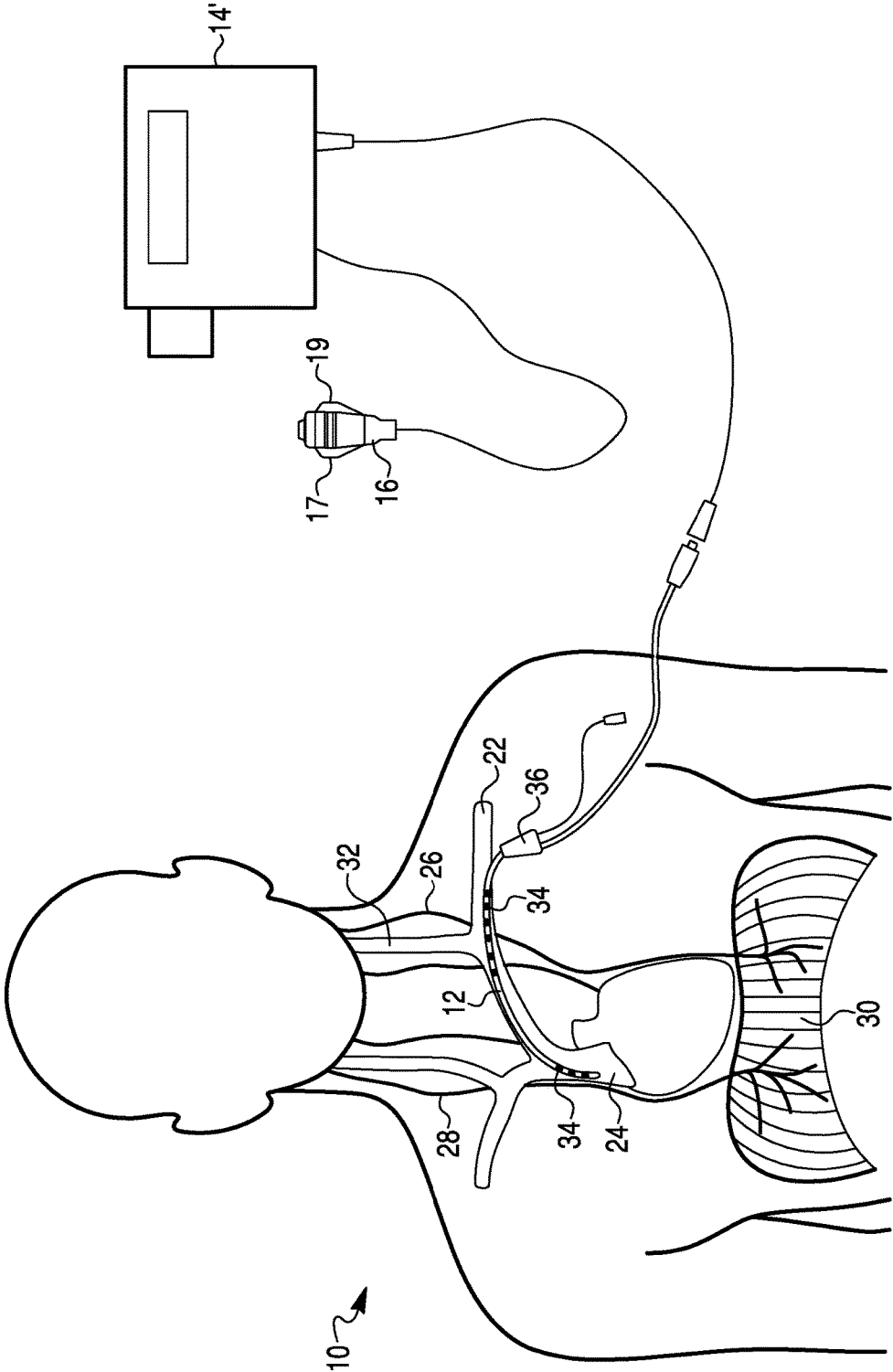

FIG. 3

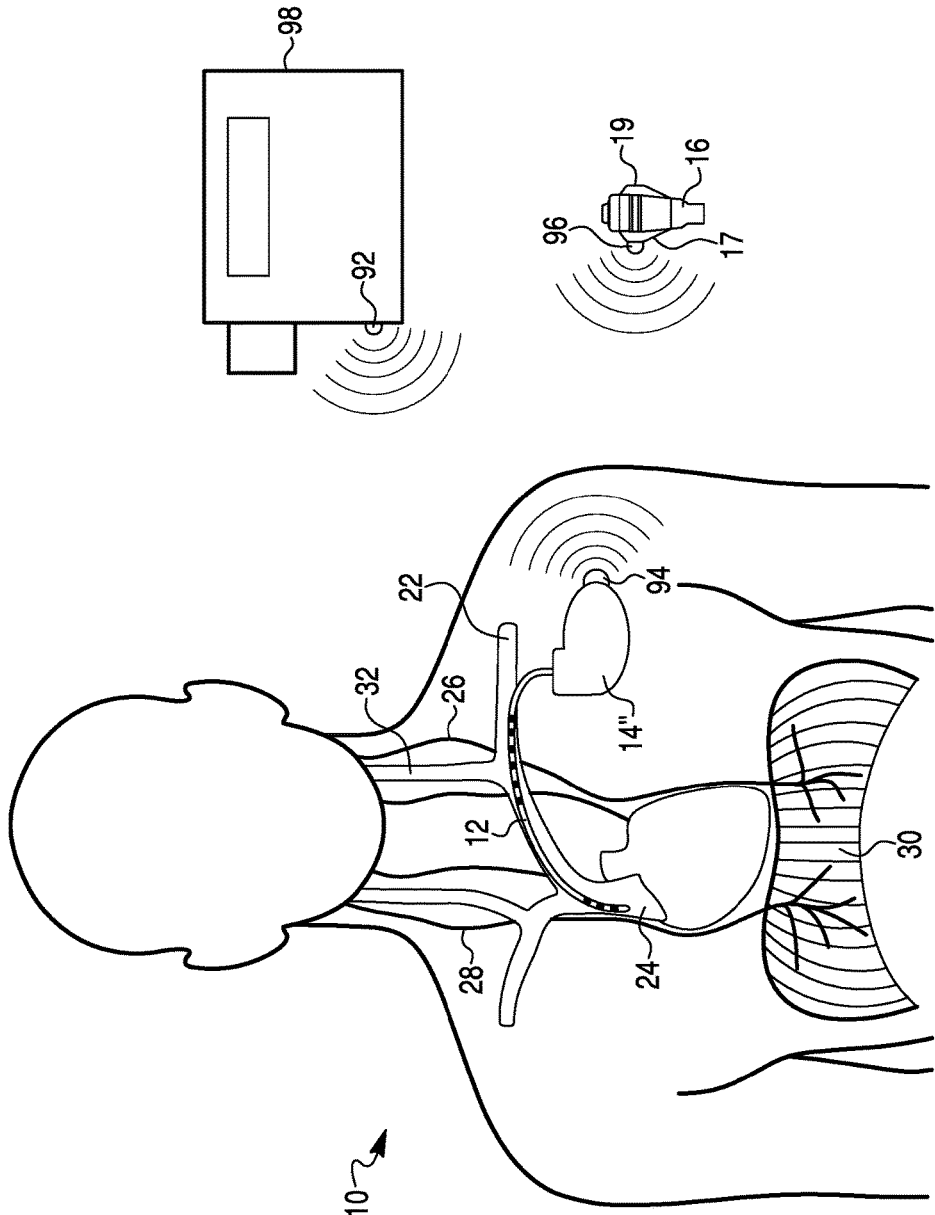

FIG. 4

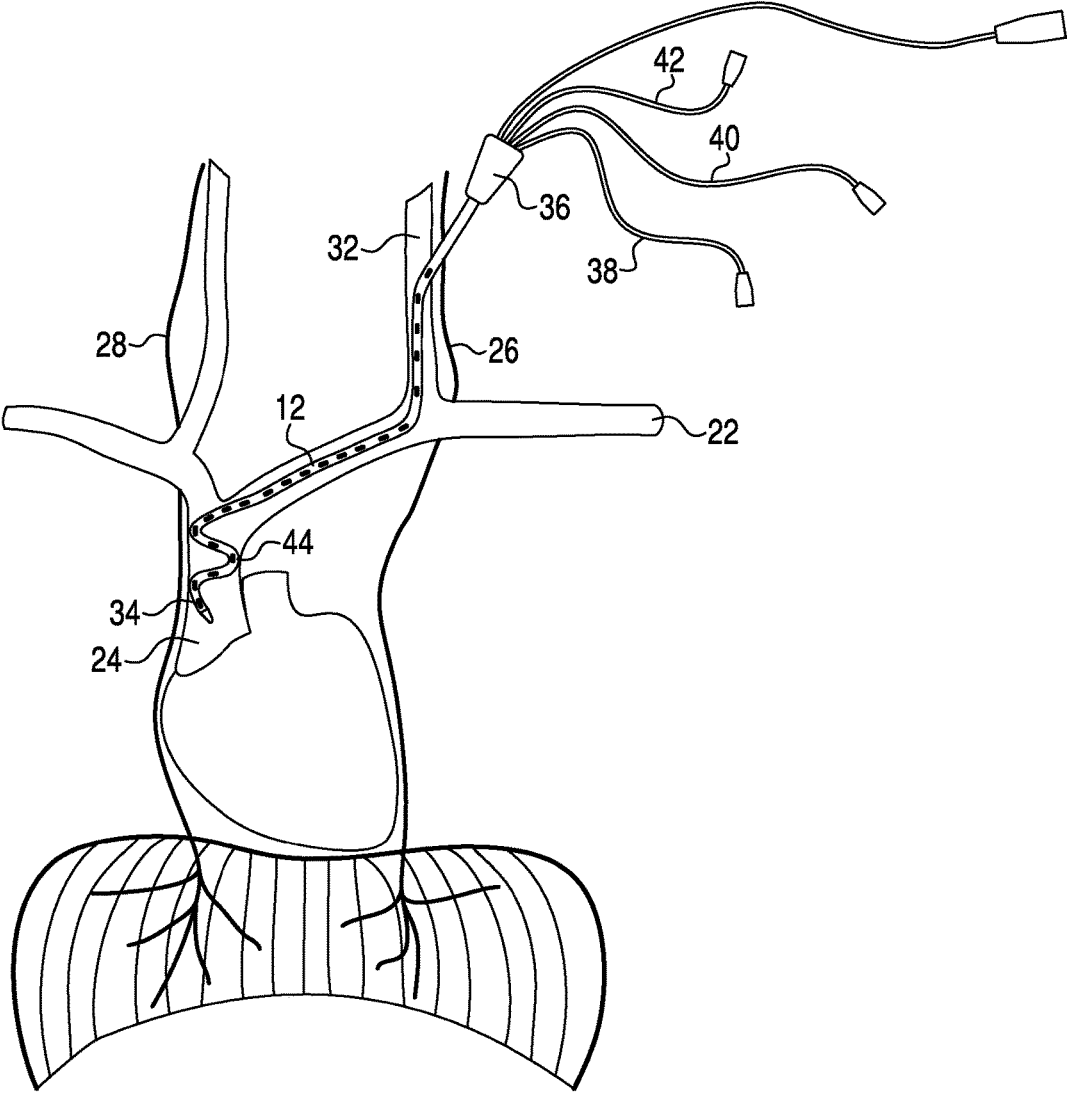

FIG. 5

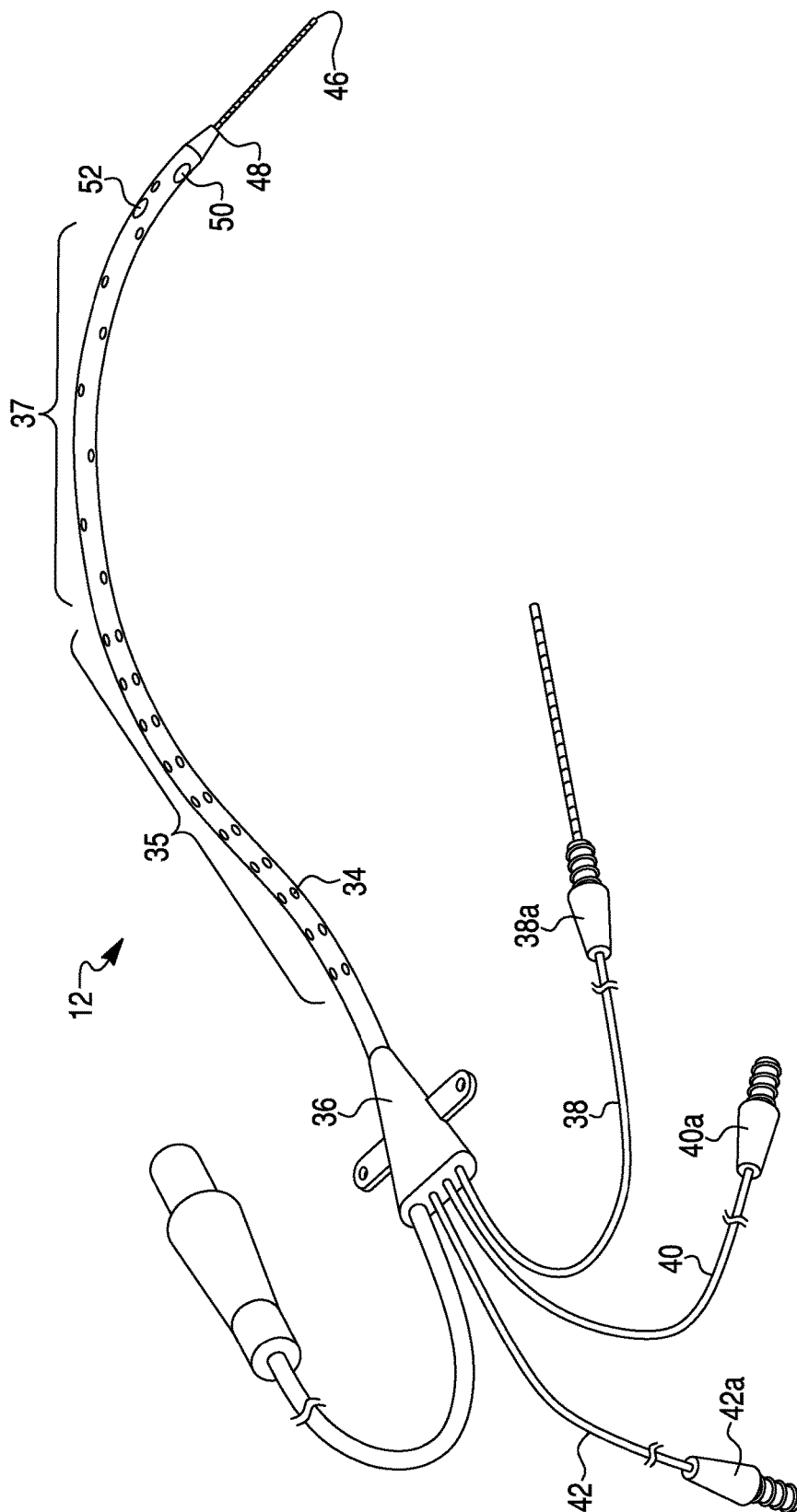

FIG. 6

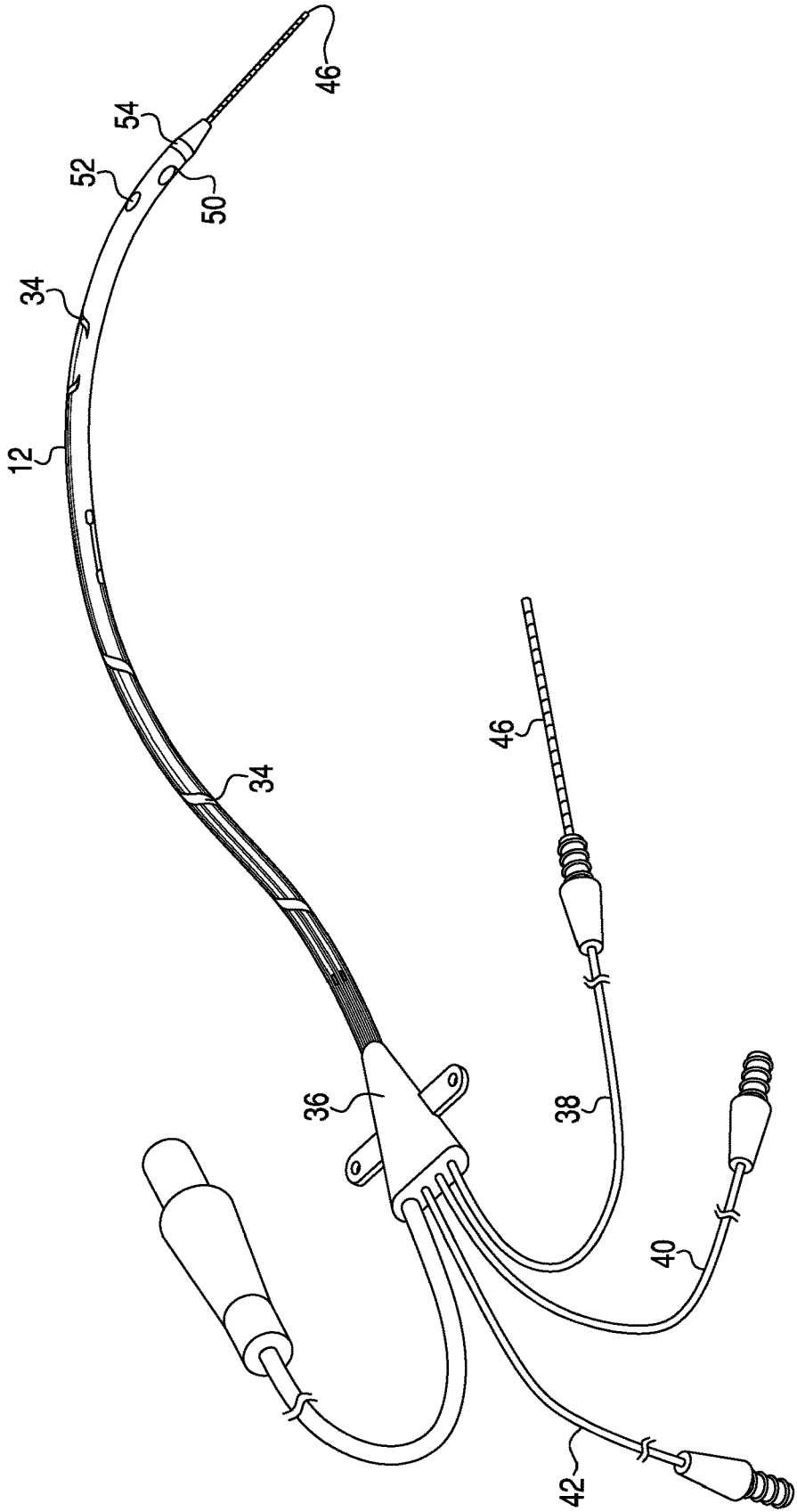
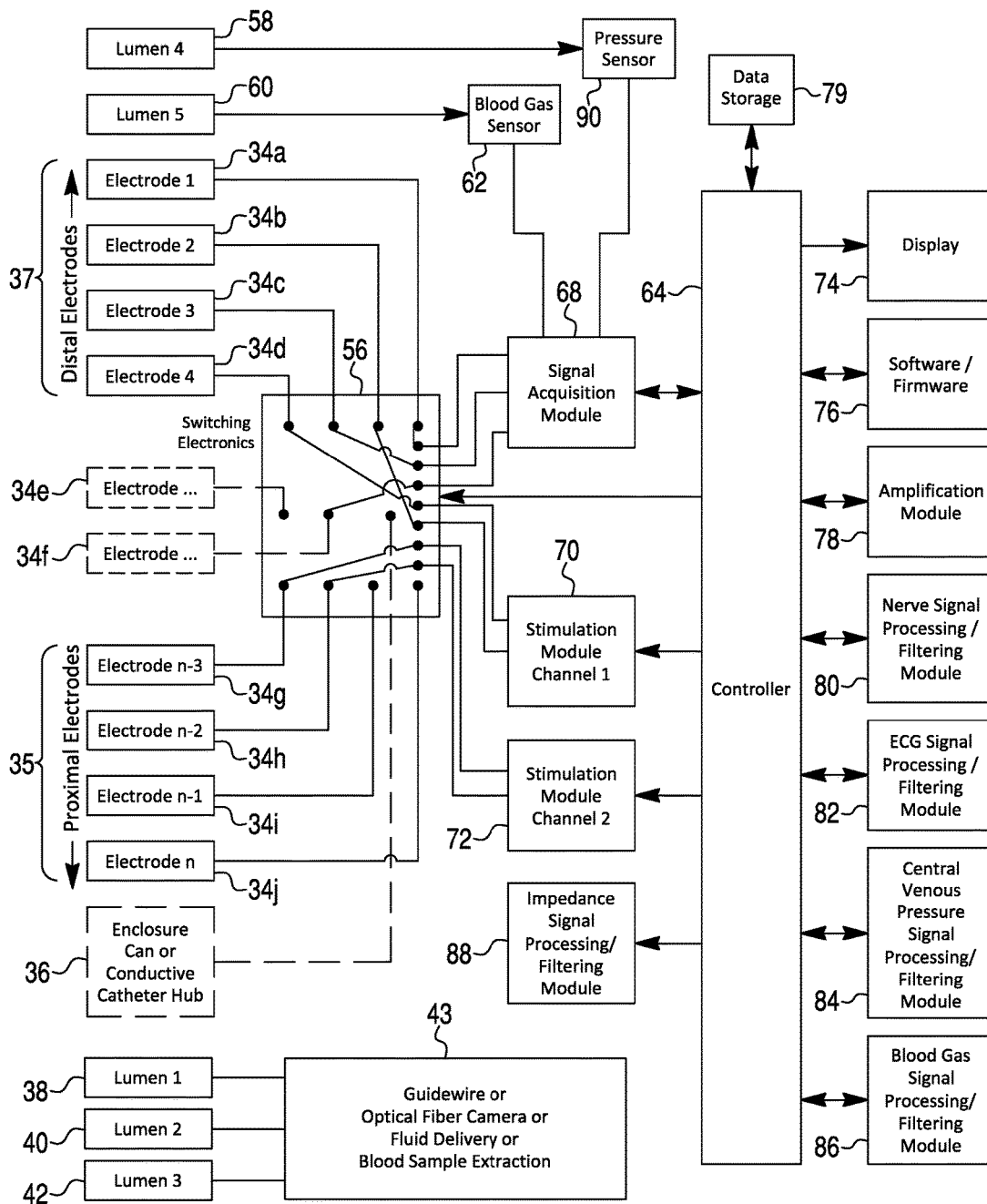

FIG. 7



**SYSTEMS AND METHODS FOR
INTRAVASCULAR CATHETER
POSITIONING AND/OR NERVE
STIMULATION**

TECHNICAL FIELD

[0001] This disclosure relates to systems, devices, and methods for one or more of positioning an intravascular nerve stimulation catheter, selecting electrodes for nerve stimulation, or stimulating nerves.

BACKGROUND

[0002] Electrical stimulation of nerves may be used to control muscle activity or to generate or attenuate sensations. Nerves and muscles may be stimulated by placing electrodes in, around, or near the nerves and muscles and by activating the electrodes by means of an implanted or external source of energy (e.g., electricity).

[0003] The diaphragm muscle provides an important function for the respiration of human beings. The phrenic nerves normally transmit signals from the brain to cause the contractions of the diaphragm muscle necessary for breathing. However, various conditions can prevent appropriate signals from being delivered to the phrenic nerves. These include: permanent or temporary injury or disease affecting the spinal cord or brain stem; Amyotrophic Lateral Sclerosis (ALS); decreased day or night ventilatory drive (e.g., central sleep apnea, Ondine's curse); and decreased ventilatory drive while under the influence of anesthetic agents and/or mechanical ventilation. These conditions affect a significant number of people.

[0004] Intubation and positive pressure mechanical ventilation (MV) may be used for periods of several hours or several days, sometimes weeks, to help critically ill patients breathe while in intensive care units (ICU). Some patients may be unable to regain voluntary breathing and thus require prolonged or permanent mechanical ventilation. Although mechanical ventilation can be initially lifesaving, it has a range of significant problems and/or side effects. Mechanical ventilation:

[0005] often causes ventilator-induced lung injury (VILI) and alveolar damage, which can lead to accumulation of fluid in the lungs and increased susceptibility to infection (ventilator-associated pneumonia, VAP);

[0006] commonly requires sedation to reduce discomfort and anxiety in acutely intubated patients;

[0007] leads to rapid atrophy of the disused diaphragm muscle (ventilator-induced diaphragm dysfunction, VIDD);

[0008] can adversely affect venous return because the lungs are pressurized and the diaphragm is inactive;

[0009] interferes with eating and speaking;

[0010] requires apparatus that is not readily portable; and

[0011] increases the risk of dying if the patient fails to regain normal breathing and becomes ventilator-dependent.

[0012] A patient who is sedated and connected to a mechanical ventilator cannot breathe normally because the central neural drive to the diaphragm and accessory respiratory muscles are suppressed. Inactivity leads to muscle disuse atrophy and an overall decline in well-being. Dia-

phragm muscle atrophy occurs rapidly and can be a serious problem to the patient. According to a published study of organ donor patients (Levine et al., *New England Journal of Medicine*, 358: 1327-1335, 2008), after only 18 to 69 hours of mechanical ventilation, all diaphragm muscle fibers had shrunk on average by 52-57%. Muscle fiber atrophy results in muscle weakness and increased fatigability. Therefore, ventilator-induced diaphragm atrophy could cause a patient to become ventilator-dependent. It has been estimated that over 600,000 U.S. patients will be ventilator-dependent and require prolonged mechanical ventilation by the year 2020. Zilberberg et al., "Growth in adult prolonged acute mechanical ventilation: implications for healthcare delivery," *Crit Care Med.*, 2008 May, 36(5): 1451-55.

SUMMARY

[0013] Embodiments of the present disclosure relate to, among other things, systems, devices, and methods for one or more of positioning an intravascular nerve stimulation catheter, selecting electrodes for nerve stimulation, or stimulating nerves. Each of the embodiments disclosed herein may include one or more of the features described in connection with any of the other disclosed embodiments.

[0014] In one example, a method for positioning an intravascular catheter may include inserting the intravascular catheter into a venous system of a patient, wherein the catheter includes a plurality of electrodes, and multiple electrodes of the plurality of electrodes are configured to emit electrical signals; positioning a distal portion of the catheter in a first position; using one or more electrodes of the plurality of electrodes to acquire an ECG signal; based on the acquired ECG signal, adjusting the distal portion of the catheter to a second position different from the first position; identifying at least one first electrode of the plurality of electrodes to stimulate a first nerve; identifying at least one second electrode of the plurality of electrodes to stimulate a second nerve; and stimulating at least one of the first and second nerves to cause a contraction of a respiratory muscle.

[0015] Any method described herein may additionally or alternatively include one or more of the following features or steps: inserting the intravascular catheter into the venous system may include inserting the intravascular catheter into: 1) at least one of a left subclavian, axillary, cephalic, cardiophrenic, brachial, radial, or left jugular vein, and 2) a superior vena cava; the first position may be proximate an atrium of a heart of the patient, and the second position may be in a superior vena cava; the ECG signal may be a first ECG signal, and the method may further comprise using one or more electrodes of the plurality of electrodes to acquire a second ECG signal; the one or more electrodes used to acquire the first ECG signal may be positioned on a proximal portion of the catheter and may be configured to stimulate the first nerve, and the one or more electrodes used to acquire the second ECG signal may be positioned on a distal portion of the catheter and may be configured to stimulate the second nerve; the method may further include comparing the first ECG signal to the second ECG signal, and based on the comparison, adjusting the distal portion of the catheter to the second position; the second position may be farther from a heart of the patient than the first position; the method may further include using one or more electrodes of the plurality of electrodes to sense at least one of an impedance or nerve

activity; or each of the at least one first electrode and the at least one second electrode may be a combination of electrodes.

[0016] In another example, a method for positioning an intravascular catheter may include inserting the intravascular catheter into: 1) at least one of a left subclavian vein or a left jugular vein, and 2) a superior vena cava, wherein the catheter includes a plurality of electrodes, and the plurality of electrodes includes a proximal set of electrodes positioned proximate a left phrenic nerve and a distal set of electrodes positioned proximate a right phrenic nerve; using one or more electrodes of the plurality of electrodes to acquire an ECG signal; based on a change in the ECG signal, withdrawing the catheter away from a heart of a patient; stimulating the left phrenic nerve using one or more electrodes of the proximal set of electrodes; and stimulating the right phrenic nerve using one or more electrodes of the distal set of electrodes.

[0017] Any method described herein may additionally or alternatively include one or more of the following features or steps: the change in the ECG signal may be a change in an amplitude of a P-wave, and the change may occur as a distal end of the catheter enters a region proximate an atrium of the heart; the step of withdrawing the catheter away from the heart may cause a change in the amplitude of the P-wave; the ECG signal may be a first ECG signal acquired by one or more electrodes of the proximal set of electrodes, and the method may further include using one or more electrodes of the distal set of electrodes to acquire a second ECG signal; the method may further include determining a difference between a P-wave of the first ECG signal and a P-wave of the second ECG signal, and withdrawing the catheter away from the heart of the patient when the difference exceeds a predetermined value; the difference may exceed the predetermined value when the catheter is advanced into an atrium of the heart; a hub coupled to the catheter and positioned exterior to the patient may be used with the one or more electrodes of the plurality of electrodes to acquire the ECG signal; or the method may further include monitoring the ECG signal as a distal end of the catheter is inserted into the at least one of the left subclavian vein or the left jugular vein and advanced into the superior vena cava.

[0018] In yet another example, a method for positioning an intravascular catheter may include inserting the intravascular catheter into a venous system of a patient, wherein the catheter includes a plurality of proximal electrodes and a plurality of distal electrodes; using one or more electrodes of the plurality of proximal electrodes to acquire a first ECG signal, and using one or more electrodes of the plurality of distal electrodes to acquire a second ECG signal; comparing the first ECG signal to the second ECG signal; based on the comparison between the first ECG signal and the second ECG signal, adjusting a position of the catheter; stimulating the first nerve using one or more of the plurality of proximal electrodes; and stimulating the second nerve using one or more of the plurality of distal electrodes.

[0019] Any method described herein may additionally or alternatively include one or more of the following features or steps: the first nerve may be a left phrenic nerve, and the second nerve may be a right phrenic nerve; comparing the first ECG signal to the second ECG signal may include comparing an amplitude of a portion of the first ECG signal to an amplitude of a portion of the second ECG signal; the step of comparing may occur a plurality of times during the

inserting step; adjusting the position of the catheter may include moving the catheter away from a heart; at least one of stimulating the first nerve or stimulating the second nerve may cause a contraction of a diaphragm; or the method may further include sensing activity of the first nerve using one or more of the proximal electrodes and sensing activity of the second nerve using one or more of the distal electrodes

[0020] In another example, a method for positioning an intravascular catheter may include inserting the intravascular catheter into: 1) at least one of a left subclavian vein or a left jugular vein, and 2) a superior vena cava, wherein the catheter includes a plurality of proximal electrodes configured to be positioned proximate a left phrenic nerve and a plurality of distal electrodes configured to be positioned proximate a right phrenic nerve; at multiple positions of the catheter during the inserting step, using one or more electrodes of the plurality of proximal electrodes to acquire a first ECG signal, and using one or more electrodes of the plurality of distal electrodes to acquire a second ECG signal; comparing the first ECG signal to the second ECG signal at several of the multiple positions; based on the comparisons of the first ECG signal to the second ECG signal, determining a desired position of the catheter for nerve stimulation; stimulating the left phrenic nerve using one or more of the plurality of proximal electrodes; and stimulating the right phrenic nerve using one or more of the plurality of distal electrodes.

[0021] Any method described herein may additionally or alternatively include one or more of the following features or steps: the method may further include advancing a distal end of the catheter into a region proximate an atrium of a heart; one of the multiple positions may be a position in which the distal end of the catheter is proximate the atrium of the heart, and in the position, the comparison may indicate a difference between an amplitude of the first ECG signal and an amplitude of the second ECG signal that exceeds a predetermined value; the method may further include moving the catheter away from the heart; stimulating the left phrenic nerve may cause a diaphragm contraction, and stimulating the right phrenic nerve may cause a diaphragm contraction; the proximal electrodes used to acquire the first ECG signal may be configured to stimulate the left phrenic nerve, and the distal electrodes used to acquire the second ECG signal may be configured to stimulate the right phrenic nerve.

[0022] It may be understood that both the foregoing general description and the following detailed description are exemplary and explanatory only and are not restrictive of the invention, as claimed. As used herein, the terms “comprises,” “comprising,” or any other variation thereof, are intended to cover a non-exclusive inclusion, such that a process, method, article, or apparatus that comprises a list of elements does not include only those elements, but may include other elements not expressly listed or inherent to such process, method, article, or apparatus. The term “exemplary” is used in the sense of “example,” rather than “ideal.”

BRIEF DESCRIPTION OF THE DRAWINGS

[0023] The accompanying drawings, which are incorporated in and constitute a part of this specification, illustrate exemplary embodiments of the present disclosure and together with the description, serve to explain the principles of the disclosure.

[0024] FIG. 1 illustrates a nerve stimulation system with an intravascular catheter positioned within a patient, according to an exemplary embodiment.

[0025] FIG. 2 illustrates a nerve stimulation system having a portable control unit, according to an exemplary embodiment.

[0026] FIG. 3 illustrates a wireless configuration of a nerve stimulation system, according to an exemplary embodiment.

[0027] FIG. 4 illustrates an intravascular catheter having a helical portion, according to an exemplary embodiment.

[0028] FIG. 5 illustrates an intravascular catheter having an optical fiber camera, according to an exemplary embodiment.

[0029] FIG. 6 illustrates an intravascular catheter having an ultrasound transducer, according to an exemplary embodiment.

[0030] FIG. 7 illustrates a block diagram of a nerve stimulation system having an intravascular catheter and a control unit, according to an exemplary embodiment.

DETAILED DESCRIPTION

[0031] When electrically stimulating nerves or muscles, a variety of goals may be considered. First, it may be desirable to place the electrodes in proximity to the phrenic nerves. Second, it may be desirable to avoid placing electrodes in close proximity to the sinoatrial (SA) node, atrioventricular (AV) node, or the His-Purkinje system located in heart tissue, as electrical stimulation of these anatomical features may cause arrhythmia. Third, when using a device that includes multiple electrodes, it may be desirable to identify particular electrodes that are in close proximity to the nerve. Identifying the proper electrodes may minimize the electrical charge required to effectively stimulate the nerves. Finally, as with any medical procedure, the risk of injury to the patient increases with the length and complexity of the medical procedure. Accordingly, it may be desirable to minimize the length of any procedure to electrically stimulate nerves or muscles.

[0032] There remains a need for cost-effective, practical, surgically simple, and minimally invasive devices and methods that address one or more of the above goals and can include one or more of a variety of functions, including: determining whether a nerve is the target nerve, stimulating breathing, delivering treatment (e.g., medications), sensing electrical signals from the body (e.g., ECG), sensing internal vascular blood pressure, heart rate, and electrical impedance, and performing tests, such as detecting respiration rate and blood gas levels (e.g., CO₂, O₂). There is also a need for devices and methods to help patients wean from mechanical ventilation and regain the ability to breathe naturally.

[0033] Accordingly, the present disclosure is drawn to systems, devices, and methods for one or more of positioning an intravascular catheter for nerve stimulation, selecting electrodes for nerve stimulation, and stimulating nerves. In particular, embodiments of the present disclosure may use various positioning features to obtain information useful for positioning a transvascular nerve stimulation catheter, or may use information gathered by sensors to select electrodes and parameters for nerve stimulation.

General System Overview

[0034] FIG. 1 illustrates a system 10 that includes a transvascular nerve stimulation catheter 12 and a control unit 14. Catheter 12 may include a plurality of electrodes 34. Catheter 12 may be operably connected (e.g., hardwired, wireless, etc.) to a control unit 14. The control unit 14 may be programmed to perform any of the functions described herein in connection with system 10. In some embodiments, the control unit 14 may include a remote controller 16 to allow a patient or health professional to control operation of the control unit 14 at a distance from the control unit 14. The controller 16 may include a handheld device, as illustrated in FIG. 1. In some examples, controller 16 may include a footswitch/pedal, a voice-activated, touch-activated, or pressure-activated switch, or any other form of a remote actuator. The control unit 14 may include a touch screen 18 and may be supported by a cart 20.

[0035] During use, a proximal portion of catheter 12 may be positioned in a left subclavian vein 22, and a distal portion of catheter 12 may be positioned in a superior vena cava 24. Positioned in this manner, electrodes 34 on the proximal portion of catheter 12 may be positioned proximate a left phrenic nerve 26, and electrodes 34 on the distal portion of catheter 12 may be positioned proximate a right phrenic nerve 28. Left and right phrenic nerves 26, 28 may innervate a diaphragm 30. Accordingly, catheter 12 may be positioned to electrically stimulate one or both of the left and right phrenic nerves 26, 28 to cause contraction of the diaphragm muscle 30 to initiate or support a patient breath. In other embodiments, the proximal portion of catheter 12 may be positioned in a left jugular vein 32, and the distal portion of catheter 12 may be positioned in superior vena cava 24.

[0036] In further examples, catheter 12 can be placed into and advanced through other vessels providing access to the locations adjacent the target nerve(s) (e.g., phrenic nerves), such as: the jugular, axillary, cephalic, cardiophrenic, brachial, or radial veins. In addition, catheter 12 may use other forms of stimulation energy, such as ultrasound, to activate the target nerves. In some examples, the system 10 can target other respiratory muscles (e.g., intercostal) either in addition to, or alternatively to, the diaphragm 30. The energy can be delivered via one or more methods including transvascular, subcutaneous, nerve cuffs, transdermal stimulation, or other techniques known in the field.

[0037] FIG. 2 illustrates an alternative example of system 10, in which control unit 14' is portable. Portable control unit 14' may include all of the functionality of control unit 14 of FIG. 1, but it may be carried by a patient or other user to provide the patient with more mobility. In addition to carrying the control unit 14', the patient can wear control unit 14' on a belt, on other articles of clothing, or around his/her neck, for example. In other examples, control unit 14' may be mounted to a patient's bed to minimize the footprint of system 10 in the area around the patient, or to provide portable muscle stimulation in the event a bed-ridden patient needs to be transported or moved to another location.

[0038] Similar to FIG. 1, the system of FIG. 2 may include a controller 16, shown as a handheld controller 16. Handheld controller 16 may include buttons 17, 19 that can be pressed by a patient or other user to control breathing patterns. In one example, pressing one of buttons 17, 19 can initiate a "sigh" breath, which may cause a greater volume of air to enter the patient's lungs than in a previous breath. A sigh breath may

result when electrodes **34** of catheter **12** are directed to stimulate one or more of the phrenic nerves **26**, **28** at a higher level than a normal breath (i.e., a stimulation train having a longer duration of stimulation or having pulses with a higher amplitude, pulse width, or frequency). Higher amplitude stimulation pulses can recruit additional nerve fibers, which in turn can engage additional muscle fibers to cause stronger and/or deeper muscle contractions. Extended pulse widths or extended durations of the stimulation train can deliver stimulation over longer periods of time to extend the duration of the muscle contractions. In the case of diaphragm muscle stimulation, longer pulse widths have the potential to help expand the lower lung lobes by providing greater or extended negative pressure around the outside of the lungs. Such negative pressure has the potential to help prevent or mitigate a form of low pressure lung injury known as atelectasis. The increased stimulation of the one or more phrenic nerves **26**, **28** may result in a more forceful contraction of the diaphragm **30**, causing the patient to inhale a greater volume of air, thereby providing a greater amount of oxygen to the patient. Sigh breaths may increase patient comfort.

[0039] In other examples, buttons **17**, **19** may allow the patient or other user to start and stop stimulation therapy, or to increase or decrease stimulation parameters, including stimulation charge (amplitude×pulse width), frequency of pulses in a stimulation train, or breath rate. LED indicators or a small LCD screen (not shown) on the controller may provide other information to guide or inform the operator regarding the stimulation parameters, the feedback from the system sensors, or the condition of the patient.

[0040] FIG. 3 illustrates another example of system **10** in which a control unit **14"** is implanted in the patient, along with catheter **12**. System **10** may further include remote controller **16** and a programmer **98** that communicates with control unit **14"** wirelessly. In this embodiment, each of programmer **98**, control unit **14"**, and remote controller **16** may include a wireless transceiver **92**, **94**, **96**, respectively, so that each of the three components can communicate wirelessly with each other. Control unit **14"** may include all of the electronics, software, and functioning logic necessary to perform the functions described herein. Implanting control unit **14"** as shown in FIG. 3 may allow catheter **12** to function as a permanent breathing pacemaker. Programmer **98** may allow the patient or health professional to modify or otherwise program the nerve stimulation or sensing parameters. Remote controller **16** may be used as described in connection with FIGS. 1 and 2. In other examples, remote controller **16** may be in the form of a smartphone, tablet, watch or other wearable device.

Catheter Features

[0041] Referring to FIGS. 1-3, catheter **12** may include a stimulation array comprising a plurality of electrodes **34** or other energy delivery elements. In one example, electrodes **34** may be surface electrodes located on an outer wall of catheter **12**. In another example, electrodes **34** may be positioned radially inward relative to the outer wall of catheter **12** (e.g., exposed through openings in the outer wall). In yet another example, the electrodes **34** may include printed electrodes as described in U.S. Pat. No. 9,242,088, which is incorporated by reference herein (see below).

[0042] Electrodes **34** may extend partially around the circumference of catheter **12**. This "partial" electrode con-

figuration may allow electrodes **34** to target a desired nerve for stimulation, while minimizing application of electrical charge to undesired areas of the patient's anatomy (e.g., other nerves or the heart). As shown in FIG. 1, catheter **12** may include a proximal set **35** of electrodes **34** configured to be positioned proximate to and stimulate left phrenic nerve **26** and a distal set **37** of electrodes **34** configured to be positioned proximate to and stimulate right phrenic nerve **28**. As shown in FIG. 5, electrodes **34** may be arranged in rows extending along the length of catheter **12**. In one example, proximal set **35** may include two rows, and distal set **37** may include two rows.

[0043] Furthermore, the catheters described herein may include any features of the nerve stimulation devices described in the following documents, which are all incorporated by reference herein in their entireties: U.S. Pat. No. 8,571,662 (titled "Transvascular Nerve Stimulation Apparatus and Methods," issued Oct. 29, 2013); U.S. Pat. No. 9,242,088 (titled "Apparatus and Methods for Assisted Breathing by Transvascular Nerve Stimulation," issued Jan. 26, 2016); U.S. Pat. No. 9,333,363 (titled "Systems and Related Methods for Optimization of Multi-Electrode Nerve Pacing," issued May 10, 2016); U.S. application Ser. No. 14/383,285 (titled "Transvascular Nerve Stimulation Apparatus and Methods," filed Sep. 5, 2014); or U.S. application Ser. No. 14/410,022 (titled "Transvascular Diaphragm Pacing Systems and Methods of Use," filed Dec. 19, 2014). In addition, the control units described herein can have any of the functionality of the control units described in the above-referenced patent documents (e.g., the control units described herein can implement the methods of nerve stimulation described in the incorporated documents).

[0044] During nerve stimulation, one or more electrodes **34** may be selected from the proximal set **35** for stimulation of left phrenic nerve **26**, and one or more electrodes **34** may be selected from the distal set **37** for stimulation of right phrenic nerve **28**. Catheter **12** may stimulate nerves using monopolar, bipolar, or tripolar electrode combinations, or using any other suitable combination of electrodes **34**. In some examples, a second or third stimulation array can be used to stimulate other respiratory muscles. When multiple nerves or muscles are being stimulated, the controller and sensors described herein may be used to coordinate stimulation to achieve the desired muscle activation, breath, or level of respiratory support.

[0045] Catheter **12** may further include one or more lumens. Each lumen may extend from a proximal end of catheter **12** to a distal end of catheter **12**, or to a location proximate the distal end of catheter **12**. The lumens may contain medical devices, such as a guidewire or an optical fiber camera. Furthermore, the one or more lumens may be used for any suitable purpose, such as drawing blood samples or providing a pathway for delivering medications into the patient. In some examples, lumens may contain or be fluidly connected to sensors, such as blood gas sensors or pressure sensors.

[0046] In this disclosure, the figures illustrating catheter **12** may each illustrate different features and different combinations of features. However, catheter **12** may include any combination of the features that are described herein. Accordingly, the features of catheter **12** are not limited to the specific combinations shown in the various figures.

[0047] Referring to FIG. 2, a hub **36** may be connected to the proximal end of catheter **12**. Hub **36** may include a

conductive surface and can act as a reference electrode during monopolar stimulation or sensing. In some embodiments, hub 36 may be sutured on a patient's skin. In addition, hub 36 may be used as an ECG electrode.

[0048] FIG. 4 illustrates catheter 12 inserted into left jugular vein 32 and superior vena cava 24. As described above, catheter 12 includes a plurality of electrodes 34, with proximal electrodes 34 positioned near left phrenic nerve 26 and distal electrodes 34 positioned near right phrenic nerve 28. Catheter 12 may further include three lumens (not shown) that connect with extension lumens 38, 40, 42 that extend proximally from hub 36. The distal portion of catheter 12 may be configured to assume a helical shape 44 when positioned within the patient. Helical shape 44 may help anchor catheter 12 to the vessel wall to stabilize catheter 12 during nerve stimulation. Furthermore, helical shape 44 may allow electrodes 34 to be positioned at different radial positions within the vessel, which may be useful when selecting electrodes for nerve stimulation. For example, in certain instances it may be desirable to stimulate the nerve with electrodes 34 that are closer to the nerve (e.g., to obtain a stronger diaphragm response), and in other instances it may be desirable to stimulate the nerve with electrodes 34 that are farther away from the nerve (e.g., to obtain a weaker diaphragm response, or prevent stimulation of the vagus nerve).

[0049] In one example, helical shape 44 may be obtained by using a stiffening wire inserted into a lumen of catheter 12 via an extension lumen 38, 40, or 42. The stiffening wire may include a shape-memory material (e.g., Nitinol) biased to a helical shape, stainless steel, or any other suitable material. The portion of catheter 12 configured to assume the helical shape 44 may include materials having a lower stiffness than other portions of catheter 12. For example, the materials along helical shape 44 may be thinner or more flexible than the materials along the remaining length of catheter 12. In another example, catheter 12 may include a temperature-activated shape memory material (e.g., Nitinol) along a portion of its length, such that the shape-memory material of catheter 12 may have a substantially straight shape at room temperature and may assume a helical shape when heated within the patient's body.

[0050] In some examples, the proximal portion of catheter 12 additionally or alternatively may have a feature, similar to the distal portion of catheter 12, to allow it to assume a helical shape when positioned within left jugular vein 32 (or left subclavian vein 22). Any proximal helical shape may be obtained or result from any of the features described in connection with helical shape 44. If both the proximal and distal portions of catheter 12 assume a helical shape when positioned within the patient, both the proximal and distal electrodes 34 may be fixed relative to the left and right phrenic nerves 26, 28, respectively. To account for body movements when the patient breathes or moves, catheter 12 may further include a helical shape along a central portion of catheter 12. In one example, the diameter of an expanded helical shape in the central portion may be less than the diameter of the vessel wall, so that the central helical shape is not fixed relative to the vessel wall. Accordingly, the central helical portion may allow catheter 12 to freely expand and contract in length within the vessel as body movements cause the distance between the proximal helix and the distal helix (which may be fixed relative to the vessel

walls) to vary. The central helical shape may be obtained or result from any of the features described in connection with helical shape 44.

[0051] Referring to FIG. 5, each of the extension lumens 38, 40, and 42 may end in a proximal-most port 38a, 40a, and 42a, respectively. Further, the lumens internal to catheter 12 may terminate in one or more distal ports. In one example, internal lumens that communicate with lumens 38, 40, and 42 terminate at a distal port 48, medial port 50, and proximal port 52, respectively. Lumens 38, 40, 42 and their corresponding internal lumens may be used to transport fluid to and from the patient, such as to deliver medications or withdraw blood or other bodily fluids. In other examples, these lumens may be used to hold a guidewire, stiffening wire, optical fiber camera, sensors, or other medical devices. FIG. 5 illustrates an optical fiber camera 46 inserted into lumen 38, extending through a corresponding internal lumen, and exiting from distal port 48.

[0052] FIG. 6 illustrates another example of catheter 12. Catheter 12 is similar to the catheter of FIG. 5, except electrodes 34 may be formed by conductive inks (such as silver, gold, graphine, or carbon flakes suspended in polymer or other media) printed on the surface of catheter 12, as described in U.S. Pat. No. 9,242,088, incorporated by reference herein (see above). These conductive inks may be deposited and adhered directly onto catheter 12 and sealed, except for the exposed electrodes 34, with an outer polyurethane or other flexible insulative film. The exposed electrodes 34 may be coated (e.g., with titanium nitride) for purposes such as one or more of: enhancing electrical properties, such as conductivity and surface area; providing corrosion resistance; and reducing the potential for formation of silver oxide, which could be toxic. As can be seen in FIG. 6, the conductive ink trace of distal electrodes may travel proximally along catheter 12 past the more proximal electrodes 34. FIG. 6 further illustrates catheter 12 having an ultrasound transducer 54 at a distal end of catheter 12, which will be described further below.

Detailed System Components

[0053] FIG. 7 illustrates a block diagram of the various components of system 10. The electrodes 34a-34j, hub 36, and lumens 38, 40, 42, 58, and 60 may be part of catheter 12 described herein. Catheter 12 may have any number of electrodes and any number of lumens. Five lumens are illustrated in FIG. 7, but in different examples, the catheter may include one, two, three, four, or more than five lumens. In one example, catheter 12 may have three lumens (e.g., extension lumens 38, 40, 42 and corresponding internal lumens), which each may hold one or more of a guidewire or optical fiber camera, or may be used for fluid delivery or blood sample extraction (box 43). In another example, catheter 12 may include four lumens, with one lumen 58 holding or fluidly connected to a pressure sensor 90, one lumen 60 holding or fluidly connected to a blood gas sensor 62, and the other two lumens holding a guidewire or optical fiber camera and/or being used for fluid delivery or blood sample extraction. It should be understood that any lumen of system 10 may contain or be fluidly connected to any of the devices (e.g., sensors, guidewire, optical fiber camera) described herein and/or may be used for any of the functions described herein (e.g., fluid delivery, blood sample extraction).

[0054] System 10 may include a controller 64, which may be part of any of the control units described herein. Each of the components of system 10 may be operably coupled to the controller 64, and controller 64 may manage operation of electrodes 34 during nerve stimulation, control the gathering of information by various sensors and electrodes 34, and control fluid delivery or extraction. It should be understood that the various modules described herein may be part of a computing system and are separated in FIG. 7 for explanatory purposes only; it is not necessary for the modules to be physically separate.

[0055] Electrodes 34a-34j may be electronically coupled to switching electronics 56, which may be communicably coupled to controller 64. As shown in FIG. 7, a portion of electrodes 34 may be distal electrodes 34a-34d, and a portion of electrodes 34 may be proximal electrodes 34g-34j. Other electrodes 34, such as electrodes 34e and 34f, may be positioned between the proximal and distal electrodes and, depending on the placement of catheter 12, may be used for stimulating either left or right phrenic nerves 26, 28. Hub 36 also may be connected to switching electronics 56 and may be used as an electrode.

[0056] Electrodes 34a-34j may be used for both electrically stimulating nerves and for gathering physiological information. When being used for nerve stimulation, a first combination of electrodes (e.g., one, two, three, or more electrodes) may be electrically coupled to a first stimulation module channel 70 for stimulation of a first nerve (e.g., the right phrenic nerve) and a second combination of electrodes (e.g., one, two, three, or more electrodes) may be electrically coupled to a second stimulation module channel 72 for stimulation of a second nerve (e.g., the left phrenic nerve). Electrical signals may be sent from the first and second stimulation module channels 70, 72 to the electrode combinations to cause the electrodes to stimulate the nerves. In other examples, more than two electrode combinations (e.g., 3, 4, or more) may be used to stimulate one or more target nerves, and system 10 may include more than two stimulation module channels.

[0057] Electrodes 34a-34f may be further configured to sense physiological information from a patient, such as nerve activity, ECG, or electrical impedance, as will be described further below. When being used for sensing, one or more of electrodes 34a-34f may be electronically coupled to a signal acquisition module 68. Signal acquisition module 68 may receive signals from electrodes 34.

[0058] Switching electronics 56 may selectively couple electrodes 34 to first stimulation module channel 70, second stimulation module channel 72, or signal acquisition module 68. For example, if an electrode 34 (e.g., electrode 34a) is being used to acquire a signal, such as an ECG signal, that electrode 34 may be coupled via switching electronics 56 to signal acquisition module 68. Similarly, if a pair of electrodes (e.g., electrodes 34b and 34d) is being used to stimulate right phrenic nerve 28, those electrodes may be coupled via switching electronics 56 to first stimulation module channel 70. Finally, if a pair of electrodes (e.g., electrodes 34g and 34h) is being used to stimulate left phrenic nerve 26, those electrodes may be coupled via switching electronics 56 to second stimulation module channel 72. Switching electronics 56 may change which electrodes 34 are used for stimulation and which are used for sensing at any given time. In one example, any electrode 34 can be used for nerve stimulation and any electrode 34 can

be used for sensing functions described herein. In other words, each electrode 34 may be configured to stimulate nerves, and each electrode 34 may be configured to sense physiological information.

[0059] Signal acquisition module 68 may further be coupled to one or more sensors configured to gather physiological information from a patient. For example, system 10 may include one or more of blood gas sensor 62 or pressure sensor 90. These sensors may be located in lumens of catheter 12, outside of the patient in fluid communication with a lumen, on an outer surface of catheter 12, or in any other suitable location. In one example, blood gas sensor 62 may be housed in or fluidly connected to lumen 60, while pressure sensor 90 may be housed in or fluidly connected to lumen 58. Blood gas sensor 62 may measure the amount of O₂ or CO₂ in the patient's blood. Pressure sensor 90 may measure the central venous pressure (CVP) of the patient.

[0060] Signal acquisition module 68 may transmit the signals received from one or more of electrodes 34, blood gas sensor 62, and/or pressure sensor 90 to the appropriate processing/filtering module of system 10. For example, signals from pressure sensor 90 may be transmitted to a central venous pressure signal processing/filtering module 84, where the signals are processed and filtered to aid in interpretation of CVP information. Similarly, signals from blood gas sensor 62 may be transmitted to a blood gas signal processing/filtering module 86 for processing and filtering to determine blood gas levels. Signals from electrodes 34, when they are used for sensing, may be sent to nerve signal processing/filtering module 80, ECG signal processing/filtering module 82, or impedance signal processing/filtering module 88, as appropriate. Signals from electrodes 34 or other sensors may be sent to amplification module 78, if necessary, to amplify the signals prior to being sent to the appropriate processing/filtering module.

[0061] Controller 64 may further communicate with display 74, which may serve as a user interface and may have a touch screen 18 (see FIG. 1). System 10 may further include software/firmware 76, which may contain the instructions necessary for carrying out the various functions described herein. Finally, system 10 may include data storage 79, for storing information gathered during sensing operations of catheter 12, and/or for storing instructions related to the operation of any of the modules or instructions for carrying out any of the functions described herein. Catheter 12 may contain unique identification features (e.g., RFID), and in the event the system 10 described herein (e.g., having one or more of controllers/programmers 14, 14', 14'', 98, 64) is used to treat multiple patients concurrently, the catheter identification feature may allow the system 10 to uniquely identify each patient and access that patient's stored patient data.

Catheter Positioning

[0062] Catheter 12 may include a variety of positioning features that may help a user to position catheter 12 within a patient. Some positioning features may be visualization aids, such as optical fiber camera 46 shown in FIG. 5 or ultrasound transducer 54 shown in FIG. 6. Other positioning features may be sensors to sense physiological parameters, such as pressure sensor 90. Electrodes 34, which can be used to stimulate a nerve, also may be used as sensors to gather information that can then be used to position catheter 12. For example, electrodes 34 may gather information related to

nerve activity (e.g., the left or right phrenic nerve), ECG signals, and/or impedance. Accordingly, a sensing electrode **34** may be considered a positioning feature. Each of the positioning features and how they are used to help position catheter **12** will be described in further detail below.

[0063] Catheter **12** may include any combination of positioning features, including one or more visualization aids, sensors (e.g., pressure), or electrodes capable of sensing various types of information. Similarly, the control units described herein, whether on a cart, wearable on a patient, or wireless, may be configured to process information gathered by the various positioning features described herein (e.g., visualization aids, sensors, and electrodes), as well as perform the various computerized functions described herein.

[0064] Referring back to FIG. 5, optical fiber camera **46** may be positioned within extension lumen **38** and its corresponding internal lumen within catheter **12**, either temporarily or as an integral, permanent component of catheter **12**. It should be understood that optical fiber camera **46** could be inserted into any of the extension lumens **38**, **40**, **42** and internal lumens, and could exit any of the ports **48**, **50**, **52**. Optical fiber camera **46** may be used to aid in positioning of catheter **12** within the patient. For example, images from optical fiber camera **46** may be transmitted in real time to a health professional or other user during a procedure, who may rely on the images to guide catheter **12** through the patient's vessels and/or to adjust the position of the catheter within the vessels.

[0065] Referring back to FIG. 6, ultrasound transducer **54** may be used in addition to or instead of optical fiber camera **46** to obtain information useful for positioning catheter **12** within the patient. Ultrasound transducer **54** may be secured temporarily or permanently to the exterior of catheter **12**, as shown in FIG. 6, or may be positioned temporarily or permanently within a lumen of catheter **12** (e.g., positioned to extend from the distal end of a lumen of catheter **12**). Positioning ultrasound transducer **54** near the distal tip of catheter **12** may allow the user to view the inside of vessels and also ensure that the tip of catheter **12** is not positioned in an undesired location (e.g., in the atrium of the heart). For example, ultrasound transducer **54** may allow visualization of a heart valve, which could indicate that the catheter **12** has entered the atrium and may need to be retracted.

[0066] In addition to allowing a user to see the inside of the patient's vessels, the ultrasound images may provide information (e.g., calculated or visual) about the diameter of blood vessels and/or blood flow within the vessels. The user may then use vessel diameter information, blood flow, and real time images of the inside of the patient's vessels to position catheter **12** in a desired position.

[0067] CVP measurements from pressure sensor **90** may further aid in positioning catheter **12** within the patient. Normal values may vary between 4-12 cm H₂O. The CVP waveform may change based on the location, relative to the patient's heart, of the port (e.g., **46**, **48**, or **50**) in communication with pressure sensor **90**. In one example, CVP measurements may decline as the relevant port approaches the patient's heart. A user may read the changing CVP waveforms to help position the catheter **12** in a desired location relative to the patient's heart.

[0068] The CVP waveform has several components. The (a) wave corresponds to the right atrial contraction and correlates with the P wave on the ECG. The (c) wave

corresponds to the cusp of the tricuspid valve protruding backwards through the atrium, as the right ventricle begins to contract. The (c) wave correlates with the end of the QRS complex on the ECG. The (x) descent corresponds to the movement of the right ventricle, which descends as it contracts. The downward movement decreases the pressure in the right atrium. At this stage, there is also atrial diastolic relaxation, which further decreases the right atrial pressure. The (x) descent happens before the T wave on the ECG. The (v) wave occurs as blood fills the right atrium and hits the tricuspid valve, causing a back-pressure wave. The (v) wave occurs after the T wave of the ECG. The (y) descent is a pressure decrease caused by the tricuspid valve opening in early ventricular diastole and occurs before the P wave of the ECG. The amplitudes of a, c, x, v, y may change depending on the position of the catheter with respect to the heart. The signature change of the CVP waveform can guide in the placement of catheter **12**.

[0069] In one example, a method for positioning intravascular catheter **12** may include positioning catheter **12** in a first position in a venous system of a patient, wherein catheter **12** includes a plurality of electrodes **34** and at least one lumen extending from a proximal end of catheter **12** to a distal end of catheter **12**, and each electrode **34** of the plurality of electrodes **34** is configured to emit electrical signals to stimulate a nerve; measuring a central venous pressure of the patient using a pressure sensor **90** fluidly connected to the at least one lumen; and based on the central venous pressure, adjusting catheter **12** to a second position different from the first position.

[0070] Nerve signals acquired by electrodes **34** also may be used to aid in positioning catheter **12** within a patient. The electrical signal from a nerve may be amplified by amplification module **78** and processed by nerve signal processing/filtering module **80**. The amplified and filtered signals from one or more electrodes **34** then may be compared to an expected signal from the targeted nerve (e.g., left or right phrenic nerve) to identify electrodes **34** in close proximity to the target nerve and to identify the optimal one or more electrodes for nerve stimulation. For example, electrodes **34** returning a higher strength and/or higher quality signal may be located closer to the target nerve.

[0071] More specifically, phrenic nerve activity can be recorded using bipolar or monopolar electrodes. Phrenic nerve discharge can be amplified and filtered (e.g., 100 Hz to 5 kHz), and a moving average can be obtained using a third-order Paynter filter with a 20 or 50 ms time constant. Phrenic nerve discharge also can be filtered at 10 Hz to 5 kHz for analysis of spectral composition. A sampling rate of 1-10 kHz can be used to capture the nerve activity.

[0072] The parameters acquired during nerve activity sensing can be used to detect if the signal is from the phrenic nerve or another nerve. Sensed parameters can include a number of physiological parameters, such as amplitude, inspiration duration, and/or breathing rate. For example, if the sensed amplitude shows proximity of the electrodes **34** to the nerve and the nerve is a phrenic nerve, the duration of pulses in a train should match the sensed inspiration duration, and the frequency of the trains should match the sensed breathing rate. Furthermore, the sensed signals from a nerve can be compared to known nerve signatures (e.g., of phrenic nerves) to confirm that the nerve signal is from the desired nerve.

[0073] Electrodes 34 (e.g., two or three) may be used to acquire ECG signals, with hub 36 optionally being used as a reference electrode. The ECG signal (e.g., morphology, amplitudes, and spectral content) may vary depending on the location, relative to the patient's heart, of the electrodes being used to measure the signal. Monitoring changes in the ECG signal as catheter 12 is being positioned may aid in identifying desired or undesired placement. For example, it may be undesired for catheter 12 to be placed in the atrium of the patient's heart.

[0074] In one example, one of the distal electrodes 34 on catheter 12 may be designated as a probe. Other electrodes along the length of catheter 12, and in some cases in contact with the skin of the patient, may be used to detect an ECG signal, which can optionally be displayed by control unit 14 via screen 18. Catheter 12 may be advanced through superior vena cava 24 towards the heart. As catheter 12 enters a region proximate the right atrium, or enters the right atrium, the P-wave portion of the ECG may become elevated and create an augmented peaked P-wave, indicating that the tip of the catheter 12 lies in or very close to the right atrium. The operator can observe the change in P-wave, or the control unit 14 can utilize an algorithm to detect the change and provide a visual, audible or other signal to the operator. For example, an LED on catheter hub 36, control unit 14, or remote controller 16 can change from green to yellow and then to red as the P-wave changes indicate that the catheter 12 is approaching and then is positioned within the right atrium. The catheter 12 can then be withdrawn slowly until the P-wave starts to diminish. The catheter 12 can then be withdrawn a further 1-2 cm, thereby positioning the catheter tip in the distal portion of superior vena cava 24.

[0075] In this example, the positive deflection in the P-wave occurs when current flows to the probing electrode, and a negative deflection when it flows away. The P-wave depolarizes down the right atrium from the SA node, away from an electrode 34 in superior vena cava 24, and is therefore negative. The amplitude of the P-wave is related to the inverse square rule, whereby the amplitude is inversely proportional to the square of the distance from the current source. Thus, the P-wave increases greatly in negative amplitude as catheter 12 approaches the atrium. When the tip enters the atrium, it is just beyond the SA node, and the first portion of the P-wave depolarizes towards it. This results in a brief, small positive deflection followed instantly by a deep negative deflection.

[0076] Alternatively, a distal combination of electrodes 34 (e.g., a distal pair) and a proximal combinations of electrodes 34 (e.g., a proximal pair) can be used to obtain, respectively, a distal and proximal ECG signal having a P-wave. The P-waves can be compared using standard signal processing techniques and a delta value can be determined as the catheter 12 is advanced through the vessel (e.g. superior vena cava 24) towards the heart. As catheter 12 is advanced in close proximity to or into the atrium, the delta value will change significantly, exceeding a predetermined value. The system 10 can provide an indicator to the operator, as described previously, and catheter 12 can be withdrawn 1 to 2 cm. This method can also utilize one or more reference electrodes 34 located along the length of the catheter or positioned externally on the patient's body.

[0077] Electrodes 34 also may be used to measure impedance, which can provide information relevant to positioning catheter 12. Impedance may be measured between any two

electrodes 34 of catheter 12. In one example, however, impedance may be measured between: a) either a proximal-most electrode 34 or hub 36, and b) a distal-most electrode.

[0078] The impedance presented to injected current may be dependent on the conductivity of the fluid, or adjacent tissue, in the local area between a pair of sensing electrodes 34. The conductivity further may depend on the cross-sectional area of the blood vessel at the site of the sending electrodes 34. The impedance of an electrode 34 may vary depending on the medium in which it is resting. For example, an electrode 34 placed in a relatively large body of conductive fluid may have a lower impedance than one resting against a vessel wall. The impedance of an electrode 34 can therefore be used to determine whether it is adjacent to a vessel wall or resting in a larger body of conductive fluid.

[0079] In one example, when catheter 12 is inserted into a patient, electrodes 34 that are on a proximal portion of catheter 12 may have a higher impedance than other electrodes 34, because the proximal portion of catheter 12 may be positioned in tissue (e.g., fatty) near an insertion site, rather than resting in the fluid of a blood vessel. Electrodes 34 farther down the shaft of catheter 12, towards a central portion of catheter 12, might have progressively lower impedances as the diameter of the vessel increases (e.g., as the vessel approaches superior vena cava 24). Electrodes 34 on the portion of catheter 12 that is floating in fluid in superior vena cava 24 might have a low impedance. Electrodes 34 on the distal portion of catheter 12, at or near the tip of catheter 12, might be in direct contact with the vessel wall and therefore may have a higher impedance. A graph of the impedances of all of the electrodes 34 in this example may have a U-shaped curvature, as impedances may be higher at each end of catheter 12 and lower towards the central portion of catheter 12. The change in impedance of an electrode 34 as it progresses through the patient's vessels can provide information about the location of that electrode 34. In addition, the differences in impedances of electrodes 34 along the length of catheter 12 may provide information about the placement of catheter 12.

[0080] In one example, catheter 12 may be placed in a vessel that varies in diameter, with distal electrodes 34 resting in a desired vessel (e.g., in superior vena cava 24). The impedances of different, more proximal electrodes would be expected to vary depending on their position in the venous system. In one example, catheter 12, when placed in a desired position, would be expected to include: 1) electrodes 34 whose impedances are reduced as the electrodes 34 approach the wall of a vessel (e.g., superior vena cava 24); and 2) electrodes 34 having impedance profiles with a desired shape. In one example, measured impedances may be compared to impedance thresholds or profiles stored in data storage 79, to determine if one or more electrodes 34 are properly placed.

[0081] In another example, the impedances of distal electrodes can be compared to the impedances of proximal electrodes as the catheter 12 is advanced through superior vena cava 24 towards the atrium. As the distal electrodes enter the atrium, the difference between the distal and proximal impedance measurements may exceed a predetermined threshold allowing the system 10 to provide an indication to the operator. Catheter 12 can then be withdrawn (or advanced depending on the application) to the desired location. Signal filtering, processing, and analytical

techniques known in the art can be used to assess the impedance measurements in real time.

[0082] A catheter **12** that is under-inserted may have few or no electrodes **34** resting in the desired vessel (e.g., superior vena cava **24**), which would result in electrode impedance profiles having different shapes than the desired shape. In addition, a catheter **12** that is over-inserted may have one or more electrodes **34** that are close to, or in contact with, the atrium, which may also result in impedance profiles having different shapes than the desired shape. In one example, the impedance of one or more electrodes **34** is monitored as catheter **12** is inserted into the patient and electrodes **34** move through the patient's venous system. Changes in the impedance profiles can be displayed to the health professional performing the insertion, and the impedance profiles can be used to confirm proper placement of catheter **12**.

[0083] In one example, a method for positioning intravascular catheter **12** may include positioning catheter **12** in a first position in a venous system of a patient, wherein catheter **12** includes a plurality of electrodes **34**, and each electrode **34** of the plurality of electrodes **34** is configured to emit electrical signals to stimulate a phrenic nerve; measuring an impedance between a first electrode **34** of the plurality of electrodes **34** and a second electrode; and based on the measured impedance, adjusting catheter **12** to a second position different from the first position.

[0084] In other examples, catheter **12** may include a strain gauge and/or an accelerometer (not shown). Either the strain gauge or the accelerometer may be placed at or near the distal end of catheter **12**, in one of the lumens. The strain gauge could detect flex in a distal portion of catheter **12**, and the accelerometer could detect movement/acceleration of the distal portion of catheter **12**. Information from the strain gauge and/or accelerometer could be used to determine whether the distal end of catheter **12** is in the atrium (e.g., heartbeats may cause movement of the distal end of catheter **12**). The strain gauge or the accelerometer could be an integral, permanent part of catheter **12** or could be positioned in a lumen of catheter **12** temporarily during positioning of catheter **12**.

Electrode Selection and Determining Stimulation Parameters

[0085] Nerve signals acquired by sensing electrodes **34** may be used to select electrodes **34** for nerve stimulation. Electrodes **34** that are closer to a target nerve may sense nerve activity having a higher amplitude, while electrodes **34** that are farther from a target nerve may sense nerve activity having a lower amplitude. If a greater diaphragm response is desired, electrodes **34** that are closer to the nerve, as determined based on received nerve activity signals, may be selected for nerve stimulation. In other cases, if less diaphragm response is desired, electrodes **34** that are farther from the nerve, as determined based on received nerve activity signals, may be selected for nerve stimulation.

[0086] Typical nerve signals for, e.g., phrenic nerves, follow a pattern that has distinct characteristics (e.g., spectral characteristics and modulation over time). To select electrodes **34** for nerve stimulation, the sensed nerve signals from different electrodes **34** can be analyzed for their spectral and temporal characteristics. Of electrodes **34** having sensed signal patterns matching typical phrenic nerve activity, the optimal electrodes **34** can be selected based on

the amplitude of the signal and how strongly the signal correlates to the typical pattern. In one example, a fast Fourier transform can be used to provide a correlation factor to a reference signal in near real-time. In another example, the sensed signals can be frequency filtered in the frequency range of interest, based on the typical characteristics of the phrenic nerve signal, and then analyzed over time to observe periods or bursts of activity in the frequency range of interest.

[0087] In one example, a method for selecting one or more electrodes for nerve stimulation may include inserting intravascular catheter **12** into: a) at least one of left subclavian vein **22** or left jugular vein **32**, and b) superior vena cava **24**, wherein catheter **12** includes a plurality of electrodes **34**, and each electrode **34** of the plurality of electrodes **34** is configured to emit electrical signals to stimulate a nerve; using one or more electrodes **34** of the plurality of electrodes **34** to acquire an electrical signal emitted from the nerve; based on the acquired electrical signal, selecting an electrode **34** or an electrode combination for a nerve stimulation; and using the selected electrode **34** or electrode combination, stimulating the nerve.

[0088] The processed nerve activity waveforms additionally may be used to determine parameters for nerve stimulation. The processed waveforms may provide information regarding intrinsic breath rate (e.g., if the patient is attempting to breathe on his/her own) and nerve signal amplitude. The stimulation parameters may be adjusted based on the breath rate of previous stimulated breaths (e.g., to increase or decrease the breath rate, as sensed by the sensing electrodes) and nerve activity resulting from stimulation during previous breaths (e.g., to increase or decrease the strength of stimulation). Various parameters that may be adjusted include stimulation pulse amplitude, stimulation pulse width, stimulation pulse frequency, stimulation duration, and the interval between stimulations/pulse trains (e.g., stimulated breath rate). Accordingly, sensed nerve activity signals may be used to determine and adjust the nerve stimulation parameters in a closed-loop system.

[0089] Impedance information may be used to determine a breath rate of the patient in order to adjust nerve stimulation parameters (e.g., stimulation pulse amplitude, stimulation pulse width, stimulation pulse frequency, stimulation duration, and the interval between stimulations/pulse trains (e.g., stimulated breath rate)). Electrical impedance of lung tissue changes as a function of air content. Accordingly, the electrical impedance of the thorax changes during inhalation and exhalation. The thorax presents an electrical impedance that includes two components: a relatively constant value and a varying value. Changes in impedance may result from the following two effects during inspiration: 1) there is an increase in the gas volume of the chest in relation to the fluid volume, which may cause conductivity to decrease, and 2) the length of the conductance path (e.g., between two electrodes) increases when the lungs expand. These effects may cause impedance to increase during inspiration. There is an approximately linear correlation between the impedance changes and the volume of respirated air. The varying component of impedance (i.e., respirative impedance) generates a varying voltage component when current is injected (e.g., by electrodes **34**). This varying voltage component can then be used to determine the person's breathing rate.

[0090] Information from blood gas sensor **62** may be used by a health professional, or by controller **64**, to adjust

stimulation parameters. For example, if blood O₂ levels are low (or blood CO₂ levels are high) controller 64 may send a signal to electrodes 34 to emit stimulation signals having a higher charge (amplitude×pulse width) or frequency, and may stimulate a sigh breath. Conversely, if blood O₂ levels are high (or blood CO₂ levels are low), controller 64 may cause electrodes 34 to emit stimulation signals having a lower charge or frequency. Based on information from blood gas sensor 62, the following parameters can be adjusted: stimulation pulse amplitude, stimulation pulse width, stimulation pulse frequency, stimulation duration, and the interval between stimulations/pulse trains (e.g., stimulated breath rate).

[0091] For any of the parameter adjustments described herein, increasing stimulation pulse amplitude, width and/or frequency may increase lung volume during a stimulated breath. Increasing stimulation duration may increase lung volume and/or increase the amount of time air remains in the lungs during a stimulated breath, allowing for an extended gas exchange period. Increasing the stimulated breath rate may allow for additional gas exchange periods over a given period of time, which may increase the amount and/or speed of gas exchange.

[0092] The system 10 and catheter 12 described herein may include any combination of sensing features. For example, catheter 12 may be configured to sense ECG, impedance, nerve activity, blood gas levels, and CVP, and the system 10 may be configured to position catheter 12, select electrodes 34 for stimulation, and select stimulation parameters based on one or more types of information received by sensors or electrodes 34.

[0093] Accordingly, the various visualization and sensing functions of system 10 may assist a user in one or more of positioning a transvascular catheter, selecting optimal electrodes for nerve stimulation, or selecting or adjusting parameters for nerve stimulation.

[0094] While principles of the present disclosure are described herein with reference to illustrative embodiments for particular applications, it should be understood that the disclosure is not limited thereto. Those having ordinary skill in the art and access to the teachings provided herein will recognize additional modifications, applications, embodiments, and substitution of equivalents all fall within the scope of the embodiments described herein. Accordingly, the invention is not to be considered as limited by the foregoing description.

1. A method for positioning an intravascular catheter, comprising:

- inserting the intravascular catheter into a venous system of a patient, wherein the catheter includes a plurality of electrodes, and multiple electrodes of the plurality of electrodes are configured to emit electrical signals;
- positioning a distal portion of the catheter in a first position;
- using one or more electrodes of the plurality of electrodes to acquire a first ECG signal and a second ECG signal;
- determining a difference between the first ECG signal and the second ECG signal;
- comparing the difference to a value;
- based on the comparison of the difference to the value, adjusting the distal portion of the catheter to a second position different from the first position;
- identifying at least one first electrode of the plurality of electrodes to stimulate a first nerve;

- identifying at least one second electrode of the plurality of electrodes to stimulate a second nerve; and
- stimulating at least one of the first and second nerves to cause a contraction of a respiratory muscle.

2. The method of claim 1, wherein inserting the intravascular catheter into the venous system includes inserting the intravascular catheter into: 1) at least one of a left subclavian, axillary, cephalic, cardiophrenic, brachial, radial, or left jugular vein, and 2) a superior vena cava.

3. The method of claim 1, wherein the first position is proximate an atrium of a heart of the patient, and the second position is in a superior vena cava.

4. (canceled)

5. The method of claim 1, wherein the first ECG signal is acquired by one or more electrodes that are positioned on a proximal portion of the catheter and are configured to stimulate the first nerve, and the second ECG signal is acquired by one or more electrodes that are positioned on a distal portion of the catheter and are configured to stimulate the second nerve.

6. (canceled)

7. The method of claim 1, wherein the second position is farther from a heart of the patient than the first position.

8. The method of claim 1, further comprising using one or more electrodes of the plurality of electrodes to sense at least one of an impedance or nerve activity.

9. The method of claim 1, wherein each of the at least one first electrode and the at least one second electrode is a combination of electrodes.

10. A method for positioning an intravascular catheter, comprising:

- inserting the intravascular catheter into: 1) at least one of a left subclavian vein or a left jugular vein, and 2) a superior vena cava, wherein the catheter includes a plurality of electrodes, and the plurality of electrodes includes a proximal set of electrodes positioned proximate a left phrenic nerve and a distal set of electrodes positioned proximate a right phrenic nerve;

- using one or more electrodes of the plurality of electrodes to acquire a first ECG signal and a second ECG signal;
- determining a difference between the first ECG signal and the second ECG signal;

- comparing the difference to a value;

- based on the comparison of the difference to the value, withdrawing the catheter away from a heart of a patient;

- stimulating the left phrenic nerve using one or more electrodes of the proximal set of electrodes; and

- stimulating the right phrenic nerve using one or more electrodes of the distal set of electrodes.

11. (canceled)

12. The method of claim 10, wherein the step of withdrawing the catheter away from the heart causes a change in an amplitude of a P-wave of the first ECG signal or the second ECG signal.

13. The method of claim 10, wherein the first ECG signal is acquired by one or more electrodes of the proximal set of electrodes, and the second ECG signal is acquired by one or more electrodes of the distal set of electrodes.

14. The method of claim 10, wherein the difference between the first ECG signal and the second ECG signal is a difference between a P-wave of the first ECG signal and a P-wave of the second ECG signal.

15. The method of claim **10**, wherein the difference exceeds the value when the catheter is advanced into an atrium of the heart.

16. The method of claim **10**, wherein a hub coupled to the catheter and positioned exterior to the patient is used with the one or more electrodes of the plurality of electrodes to acquire the ECG signal.

17. The method of claim **10**, further comprising monitoring the first ECG signal and the second ECG signal as a distal end of the catheter is inserted into the at least one of the left subclavian vein or the left jugular vein and advanced into the superior vena cava.

18. A method for positioning an intravascular catheter, comprising:

inserting the intravascular catheter into a venous system of a patient, wherein the catheter includes a plurality of proximal electrodes and a plurality of distal electrodes; using one or more electrodes of the plurality of proximal electrodes to acquire a first ECG signal, and using one or more electrodes of the plurality of distal electrodes to acquire a second ECG signal; determining a difference between the first ECG signal and the second ECG signal; comparing the difference to a value; based on the comparison of the difference to the value, adjusting a position of the catheter; stimulating the first nerve using one or more of the plurality of proximal electrodes; and stimulating the second nerve using one or more of the plurality of distal electrodes.

19. The method of claim **18**, wherein the first nerve is a left phrenic nerve, and the second nerve is a right phrenic nerve.

20. The method of claim **18**, wherein the difference between the first ECG signal and the second ECG signal is a difference between an amplitude of a portion of the first ECG signal and an amplitude of a portion of the second ECG signal.

21. The method of claim **18**, wherein the steps of determining the difference and comparing occur a plurality of times during the inserting step.

22. The method of claim **18**, wherein adjusting the position of the catheter includes moving the catheter away from a heart.

23. The method of claim **18**, wherein at least one of stimulating the first nerve or stimulating the second nerve causes a contraction of a diaphragm.

24. The method of claim **18**, further comprising sensing activity of the first nerve using one or more of the proximal

electrodes and sensing activity of the second nerve using one or more of the distal electrodes.

25. A method for positioning an intravascular catheter, comprising:

inserting the intravascular catheter into: 1) at least one of a left subclavian vein or a left jugular vein, and 2) a superior vena cava, wherein the catheter includes a plurality of proximal electrodes configured to be positioned proximate a left phrenic nerve and a plurality of distal electrodes configured to be positioned proximate a right phrenic nerve;

at multiple positions of the catheter during the inserting step, using one or more electrodes of the plurality of proximal electrodes to acquire a first ECG signal, and using one or more electrodes of the plurality of distal electrodes to acquire a second ECG signal;

determining a difference between the first ECG signal and the second ECG signal at several of the multiple positions;

comparing each difference to a value;

based on the comparisons of each difference to the value, determining a desired position of the catheter for nerve stimulation;

stimulating the left phrenic nerve using one or more of the plurality of proximal electrodes; and

stimulating the right phrenic nerve using one or more of the plurality of distal electrodes.

26. The method of claim **25**, further comprising advancing a distal end of the catheter into a region proximate an atrium of a heart.

27. The method of claim **26**, wherein one of the multiple positions is a position in which the distal end of the catheter is proximate the atrium of the heart, and in the position, the comparison indicates a difference between an amplitude of the first ECG signal and an amplitude of the second ECG signal that exceeds the value.

28. The method of claim **27**, further comprising moving the catheter away from the heart.

29. The method of claim **25**, wherein stimulating the left phrenic nerve causes a diaphragm contraction, and stimulating the right phrenic nerve causes a diaphragm contraction.

30. The method of claim **25**, wherein the proximal electrodes used to acquire the first ECG signal are configured to stimulate the left phrenic nerve, and the distal electrodes used to acquire the second ECG signal are configured to stimulate the right phrenic nerve.

* * * * *