



(72) Gitlin, Richard Dennis, US

(72) I, Chih-Lin, US

(73) AT&T CORP., US

(51) Int.Cl.⁶ H04B 1/04, H04J 13/00

(30) 1994/05/13 (242,471) US

(54) **SYSTEME A ACCES MULTIPLE PAR DIFFERENCE DE CODE
OFFRANT UN CHOIX DE DEBITS D'ACCES A
L'UTILISATEUR**

(54) **CODE DIVISION MULTIPLE ACCESS SYSTEM PROVIDING
VARIABLE DATA RATE ACCESS TO A USER**

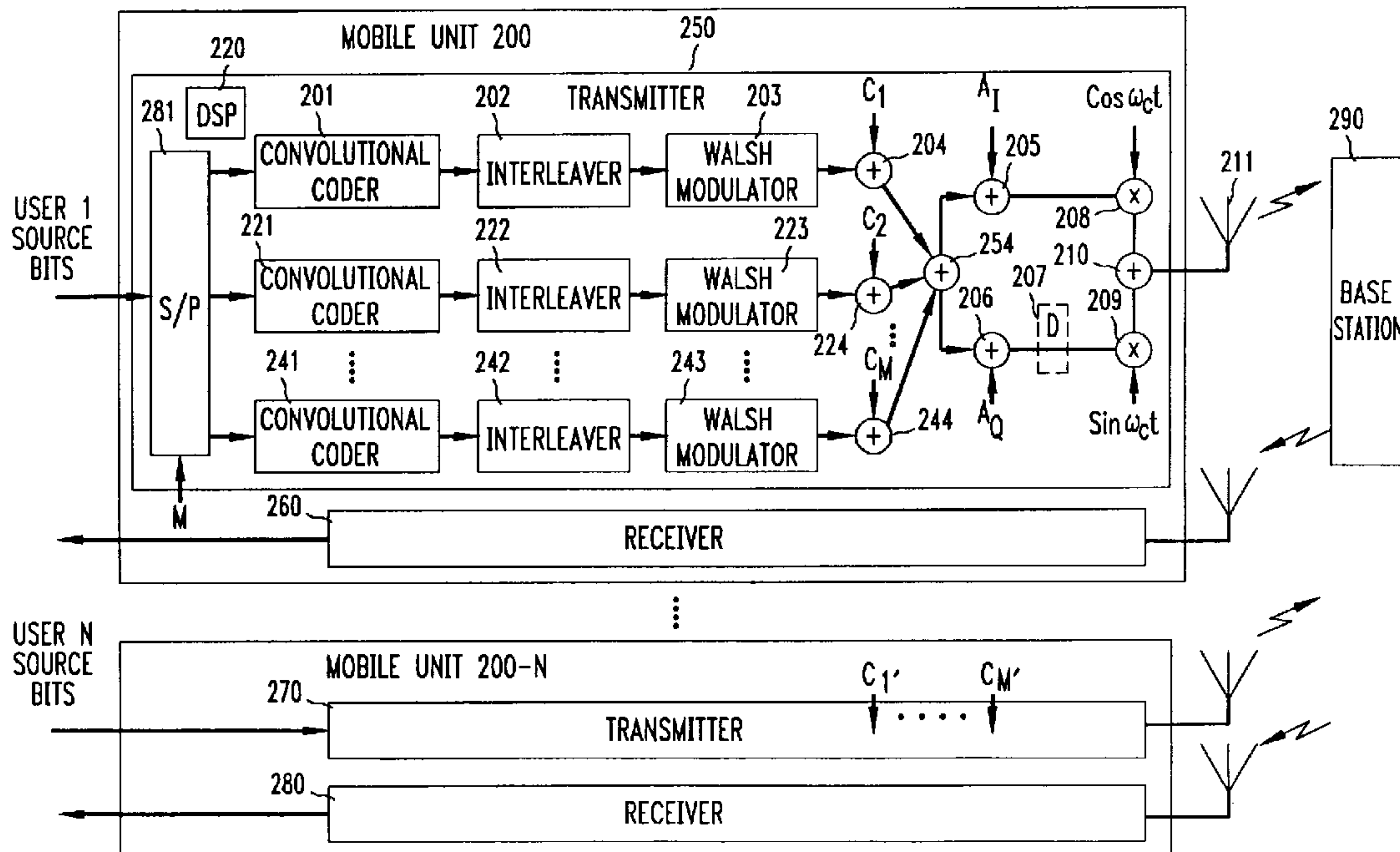

(57) A multi-code code division multiple access system allows a user at a radio transmitter unit to dynamically change its source data bit rate. In response to a user input selecting one of said plurality of source bit rates, an adjustable coding means in the transmitter spreads and transmits the user's digital bit stream received at the selected bit rate to a channel bit rate which at least equals the highest bit rate of said plurality of source bit rates. The plurality of source bit rates includes a basic bit rate R and at least one bit rate which is a multiple M of the basic bit rate R , where M is an integer of at least 1. The user's input selects a particular user source bit rate by identifying a basic bit rate multiple M to a base station that is to receive the transmission.



**Code Division Multiple Access System Providing
Variable Data Rate Access To A User**

Abstract

5 A multi-code code division multiple access system allows a user at
a radio transmitter unit to dynamically change its source data bit rate. In response
to a user input selecting one of said plurality of source bit rates, an adjustable
coding means in the transmitter spreads and transmits the user's digital bit stream
received at the selected bit rate to a channel bit rate which at least equals the
10 highest bit rate of said plurality of source bit rates. The plurality of source bit
rates includes a basic bit rate R and at least one bit rate which is a multiple M of
the basic bit rate R , where M is an integer of at least 1. The user's input selects a
particular user source bit rate by identifying a basic bit rate multiple M to a base
station that is to receive the transmission.

15

Figure 2

**CODE DIVISION MULTIPLE ACCESS SYSTEM PROVIDING
VARIABLE DATA RATE ACCESS TO A USER**

Field of the Invention

This invention relates to code division multiple access (CDMA) systems and, more particularly, to a CDMA system for providing a user with variable and dynamic bandwidth capacity access.

Background of the Invention

In future wireless networks, a large variety of services, such as voice/video/data/image, are expected. The most precious resource in most wireless systems is the radio spectrum. To maximize its effective use, packet switched wireless access using code division multiple access (CDMA) has been pursued and offers increased service quality and transmission bandwidth. These CDMA systems provide reduced multiple path distortion and co-channel interference, and avoid the need for frequency planning that is common with frequency division multiple access (FDMA) and time division multiple access (TDMA) systems.

In a CDMA system, a unique binary spreading sequence (a code) is assigned for each call to each user. Multiplied by the assigned code, the user's signal is "spread" onto a channel bandwidth much wider than the user signal bandwidth. The ratio of the system channel bandwidth to the user's bandwidth is commonly called "the spreading gain." All active users share the same system channel bandwidth frequency spectrum at the same time. Given a required signal-to-interference (S/I), the equivalent system capacity is proportional to the spreading gain. The signal of each user is separated from the others at the receiver by using a correlator keyed with the associated code sequence to "de-spread" the desired signal.

In these CDMA systems, there is a continuing need to increase the performance of the system by accommodating users having different source rates.

Summary of the Invention

In accordance with the present invention, a multi-code CDMA system allow a user at a radio transmitter unit to dynamically change its source data rate. In response to a user input selecting one of said plurality of source bit rates, an adjustable coding means spreads and transmits the user's digital information received at the selected bit rate to a channel bit rate which at least equals the highest bit rate of said plurality of source bit rates. According to one feature, the plurality of source bit rates includes a basic bit rate R and at least one

bit rate which is a multiple M of the basic bit rate R , where M is an integer of at least 1. The user's input selects a particular user source bit rate by identifying a basic bit rate multiple M to a base station that is to receive the transmission.

Brief Description of the Drawing

5 FIG. 1 shows a prior art CDMA system;

 FIG. 2 shows a block diagram of a first embodiment of a transmitter unit of a multi-code CDMA system in accordance with the present invention;

10 FIG. 3 shows a block diagram of a second embodiment of a transmitter unit of a multi-code CDMA system;

 FIG. 4 shows a block diagram of a third embodiment of a transmitter unit of a multi-code CDMA system;

 FIG. 5 shows a flow chart describing how a user can dynamically change the source data bit transmission rate of the transmitter unit; and

15 FIG. 6 shows an illustrative base station uplink load graph.

Detailed Description

 With reference to FIG. 1, we describe a prior art CDMA system. The CDMA system includes a plurality of mobile units (1 - N) which enables a plurality of users (1 - N) to communicate with a base unit 190 at one cell site. Illustratively, a block diagram of mobile unit 1 includes a transmitter unit 150 and a receiver unit 160. The transmitter unit 150 includes a convolutional coder 101 which receives digital information (or data signals) from user 1 at a first data bit rate. The output of convolutional coder 101 is coupled to interleaver 102 and then to a Walsh modulator 103, all of which are well known in the prior art. The output of modulator 103 is outputted into code spreader 104, which spreads the first data bit rate signal into a channel bit rate using a code C_1 which is unique to user 1. The output signal 104a of code spreader 104 is coupled to coders 105 and 106. In coder 105, an in-phase code A_1 further encodes the signal 104a. Similarly, coder 106 further encodes the signal 104a using a quadrature-phase code A_2 . The codes A_1 and A_2 are common to mobile units 1 - N, but are unique to the cell site base unit 190 which serves mobile units 1 - N. This ensures that mobile units 1 - N can only communicate with base station 190.

 The output of coder 105 is used to modulate the carrier signal $\text{Cos}\omega_c t$ in modulator 108. The output of coder 106 is used to modulate the carrier signal $\text{Sin}\omega_c t$ in modulator 109. In certain applications, an optional delay unit 107 may be utilized to provide better spectral shaping. The output of

modulators 108 and 109 are radio frequency signals which are combined in combiner 110 and transmitted via antenna 111 over the air to base unit 190.

5 The base unit 190 transmits at a different carrier frequency which is received and decoded by mobile units 1 - N. In our illustrative example, receiver 160 of mobile unit 1 includes a demodulator (not shown) to demodulate the carrier frequency to obtain a channel bit rate signal which is decoded using codes A_1 and A_2 and then de-spread using the associated code sequence C_1 to obtain the information data signal to be outputted to user 1.

10 The base unit 190 operates in a similar manner to receiver 160 of mobile unit 1 to receive, decode and de-spread the user 1 information data signal. Similarly, the other mobile units, illustratively represented by mobile unit N, operate in the same manner as mobile unit 1, except that user N has a unique code CN to distinguish it from user 1. In mobile unit N, the in-phase and quadrature codes A_1 and A_2 , respectively, as well as the carrier frequency f_c ,
15 are the same as used for mobile unit 1.

When a higher data transmission rate is desired, one prior art arrangement provides the user a multi-code mobile unit having a fixed number of multiple transmitters and receiver units, each using a different spreading code. Thus, for example, if a user required twice the bandwidth, the user terminal
20 would include two transmitter units 150 and two receiver units 160, which operate using different codes C_1 and C_2 . Such an arrangement is described in Wi-LAN Inc. Technical Bulletin No. 3 dated October 1993 and entitled "Multicode Direct Sequence Spread Spectrum." In such an arrangement, however, the user is allocated a predefined fixed bandwidth and all users, when
25 they transmit, would transmit at the same fixed source rate.

With reference to FIG. 2, we describe our dynamic multi-code code division multiple access (MC-CDMA) system. In FIG. 2, the units 205-211 operate in the same manner as the previously described units 105-111 of FIG. 1 and coder units 201-204, 221-224, and 241-244 operate the same as coder units
30 101-104 of FIG. 1. The units 280, 201-204, and 221-224 may each be implemented using a Digital Signal Processor (DSP) or may be combined in one or more DSPs. Illustratively, the DSP is shown as a separate unit 220 which controls the mobile unit 200. The combiner 254 combines the output of code spreaders 204, 224 and 244. The serial-to-parallel unit 281 converts a user's serial digital information input, which may be up to M_{\max} times the basic source
35 rate R (where $M_{\max} \cdot R \leq$ channel rate), into M data streams (where M is an

integer $\leq M_{\max}$) each of which is encoded using one of the coder units (e.g., 201-204). The variable M is selected by a user and/or the base station 290 depending on system status, as will be discussed in a later paragraph. It should be noted that the Walsh modulators 203, 223 and 243 are optional, to improve the required signal-to-interference ratio, and in accordance with an aspect of the invention may be eliminated to improve the bandwidth multiple M_{\max} .

In an MC-CDMA system of FIG. 2, if a user 1 requests (and is allowed by the base station 290) M times the basic source rate R , mobile unit 1 converts the user digital stream, User 1, (using serial-to-parallel unit 280) into M basic rate streams. Each of the basic rate streams is encoded using a different code ($C_1 - C_M$) and they are superimposed together (using combiner 254) and up-converted (using units 208, 209) for radio transmission to the base station 290. The codes $C_2 - C_M$ are derived from C_1 using a subcode concatenation that is described in a later paragraph.

As shown in FIG. 2, such a system does not require modification to the phase encoders 205, 206 or to the RF modulators 208, 209, except for using M times the transmission power (in unit 210) to satisfy the signal-to-interference requirements. All additional processing needed in the MC-CDMA mobile unit 1 is done in the baseband region using digital signal processors (DSPs). As will be described in a later paragraph, each mobile unit 200 through 200 - N is assigned a different primary code $C_1 \dots C'_1$ by base station 290.

In an alternate embodiment shown in FIG. 3, variable rate convolutional coder, interleaver and Walsh modulator (units 301-303) can be utilized in the MC-CDMA mobile unit 300. In such an arrangement, the bandwidth of units 301-303 is set by the input M . The serial-to-parallel unit 381 is connected to the output of Walsh modulator 303 and converts the user's input digital information stream into M basic data rate serial information streams. The remaining units 304 through 311, 324, 344 and 354 function in the same manner as units 204 through 211, 224, 244 and 254 as previously described in FIG. 2. The receiver unit 360 operates in the same manner as unit 260 of FIG. 2.

An additional embodiment shown in FIG. 4 describes the use of a convolutional coder, interleaver and Walsh modulator (units 401-403) which operate at a constant chip data source rate which is C times the basic data rate R . Because units 401-403 operate at a constant chip rate, they are more simply realized. The user's input digital information stream (at a data rate which is equal to M times the basic data rate R) is inputted to a repeater 421. The repeater 421

multiplies the user digital information stream (at a data rate of M times R) by a factor C/M such that the resulting data bit rate is equal to C times the basic data bit rate R . The random selector circuit 422 connects to the output of Walsh modulator 403 and randomly selects one of the C/M blocks of data. The output of selector circuit 422 is then inputted into serial-to-parallel unit 481 which operates the same as unit 381 of FIG. 3 to generate M data streams. Similarly, the units 404 through 411, 424 and 444 operate in the same manner as units 304 through 311, 324 and 344 of FIG. 3. The receiver 460 operates in the same manner as unit 360 of FIG. 3.

10 **Rate Quantization**

On the transmitter side, the actual user source bit rate does not have to be an integer multiple of the basic rate R . Each code ($C_1 - C_M$) in MC-CDMA carries a basic rate R . If one of the codes is equipped with sub-rate capability (i.e., variable spreading gain to provide $1/2$ rate, $1/4$ rate, etc.), then there is a much finer quantization in terms of the source bit rate offering to the user. Thus, for example, the user would be able to transmit at 3.25 times the basic rate B .

Synchronization/Acquisition

On the receiver side, the synchronization/acquisition subsystem is very demanding even for regular CDMA systems. The MC-CDMA receiver does not require an M -fold complexity increase in synchronization/acquisition. Since the multipath/delay spread suffered by signals carried on the parallel codes to/from one user would be exactly the same, one well-known searcher circuit for acquisition will suffice for the multiple paths receiver (RAKE) fingers of all the parallel codes.

Subcode Concatenation

To avoid the self-interference that a user employing multiple codes may incur, the present invention provides a subcode concatenation scheme to generate additional codes for the user. The scheme operates as follows: Each user admitted into the system has a primary code assigned to it by the base station. The primary codes (i.e., C_1 , C'_1 , etc.) of different users are PN codes, i.e., not orthogonal among different users. The multiple codes to/from one user can and should be made orthogonal. If C_1 is the primary code of a user and the user requires a higher rate, the additional codes, C_i , will be derived from C_1 by

$$C_i = C_1 \times D_i, \text{ where } D_i \perp D_j, i \neq j.$$

Obviously, $C_i \perp C_j, i \neq j$. This orthogonality is maintained at the receiver since the propagation variations on the parallel codes are the same. In addition to the ability of eliminating self-interference, this scheme helps simplify dynamic access in the sense that explicit multiple code negotiation is not needed. The latter will be made clear in the next section.

Dynamic Access Control

10 To provide the user dynamic bandwidth access control between bursts, two different approaches may be taken: one uses a demand assignment approach; another uses a probabilistic approach.

15 Taking a demand assignment approach, users (i.e., mobile units) with data bursts to transmit or users with increased source rates must make requests and wait for assignment by the base station. In conventional orthogonal systems, the assignment (e.g., using well-known RAMA/TRAMA access protocols) gives specific time slots and/or carriers to the user. In our MC-CDMA system, only the *number* of codes needs to be dynamically assigned by the base station. Each user has a unique primary code, i.e., C_1 , assigned to it at call setup time. When a user is idle, a very low rate (sub-rate) signaling channel is maintained using its primary code. Not only does this sub-rate channel facilitate synchronization and power control procedures, but also it is used to make multiple code requests prior to a burst transmission. Depending on the user need and the uplink load status, an assignment is made to the requesting user. Upon receiving the *number* assignment from the base station, the user utilizes subcode concatenation to locally generate the corresponding number of codes for its transmission while the receiver at the base station does the same. There is no need for explicit code negotiation. The user, then, transmits at a power level adjusted according to the number of codes it uses as well as the QOS it requires.

30 The demand assignment access described above uses transmitter-oriented codes. By way of the low-rate maintenance channel, it assures continuous synchronization and power control. This approach requires a dedicated receiver and a dedicated maintenance channel for every user admitted

into the system. Alternatively, a common code or a few common codes can be reserved for the burst access request by all users. Such access with receiver-oriented codes will do away with the dedicated resources. However, this approach has the disadvantage of a very significant burst access delay due to access collision as well as the time needed to re-acquire synchronization and power control for every burst.

Taking the probabilistic approach, adaptive access control can be employed. One such technique is described in commonly assigned U.S. Patent Nos. 5,784,360 issued July 21, 1998 and 5,671,218 issued September 23, 1997. The base station broadcasts to the mobile units the current uplink load information. Users that have data bursts to transmit will then make probabilistic decisions on whether to transmit. For the decision-making, one useful criterion is that the conditional expected load, given the current load, is optimized. Another criterion is that the conditional probability of the system overload, given the current load, is optimized. As described in the above-cited application, priority for users with on-going bursts over users with new bursts may be desirable and can be incorporated in this control mechanism. Furthermore, since MC-CDMA users are equipped with a variable rate capability, the decision does not have to be the probability of transmission. Instead, given the current load information, a user can decide to transmit at a lower, yet non-zero, source rate by using a fewer number of codes. The probabilistic approach is attractive in that the user access can be instantaneous, and no central controller is required to dynamically assign spectral resource among users in the cell. The disadvantage of this approach is that the system overload occurs with non-zero probability, which will degrade the overall spectral efficiency.

With reference to the flow chart of FIG. 5, we describe an illustrative sequence of system operations for both the demand assignment and probabilistic approach. In step 501, the user inputs a request for a connection over a common access channel used for communications with the base station. Communications between a mobile unit and the base station may use the previously described RAMA/TRAMA protocol or other access protocols. In step 503, if the connection is not successful, it is re-tried in step 505. If it is successful, then in step 507 the base station assigns a primary code C_1 to the mobile unit over the broadcast channel. The base station prevents collision of

transmissions from each of the mobile units by selecting unique primary codes for each mobile unit which is active. Thus, for example, one mobile unit may be assigned a primary code C_1 ; another is assigned a primary code C_1' .

5 Returning to our example, following step 507, the user can then communicate to the base station at the basic rate R using the primary code C_1 . If the user desires to transmit at other than the basic rate, a request is made as is shown in step 509. In step 509, the user requests M times the basic rate R bandwidth for communications to the base station. Such additional bandwidth may be required by a user that transmits in a burst data mode. The base station, 10 depending on the available bandwidth not presently being utilized by other mobile units, may allow the user to transmit at M' times the basic rate R (where M' is less than or equal to M). In step 513 when the user receives permission to transmit at M' times the basic rate R , the user generates the codes C_2 through $C_{M'}$ using the previously assigned primary code C_1 .

15 At the end of a data burst, when the user returns to an idle mode, subrate signaling is maintained over the C_1 channel. In step 517, it is determined if the user has a new data burst. If the user has a new data burst, control returns to step 509. If there is no new data burst, then in step 519 it is determined whether or not the communications channel should be disconnected, step 521. If 20 the user does not wish to disconnect, control returns to step 515.

For users operating in an isochronous mode (i.e., user is sending continuous data transmissions), the path 522 would be substituted for steps 515 and 517.

25 If the probabilistic approach is used by a user, then the following sequence of steps is followed. Following step 507, the base station, in step 523, broadcasts the uplink load to all users on the system. The user monitors the uplink load and makes a probabilistic determination of being able to transmit at a multiple M of the basic rate R . One criterion for the decision making could be that the conditional expected load, given a current uplink load, is optimized. 30 Furthermore, given the current uplink load information, a user could then decide to transmit at a lower, yet non-zero, source data rate by using a smaller multiple M . In step 525, the user determines at which multiple M to transmit to the base station.

35 Optionally, via path 526 following step 507, the base station may, in step 527, transmit to the user the probability of success for transmitting at

different multiples M of the basic rate R . Thereafter, the user uses these probabilities to determine at which multiple M to transmit.

To illustrate how the base station handles a user request for additional transmission bandwidth, consider the base station uplink load graph shown in FIG. 6. Assume that a base station has a maximum bandwidth capacity of M_{\max} (e.g., 5) times the basic rate R . At time T_1 all of the bandwidth has been assigned; hence, any request from a user for an increased transmission bandwidth would be denied. At time T_2 , however, only 40% of the bandwidth capacity is being utilized; at time T_3 , 80%; at time T_4 , 20%; and at time T_5 , 0%.

At time T_2 assume an active user wants to increase its bandwidth by a multiple $M = 3$ of its basic rate R . The base station could allow that user to utilize a multiple 3; however, the base station would then have no residual bandwidth capacity for newly active users or for increasing the bandwidth of existing active users. In such a situation, the base station would likely allow the requesting user to utilize a multiple M of 2 or 1, thereby leaving a reserve bandwidth for other needs of the system. Assuming the base station allows the user a multiple $M = 2$, the new base station loading would appear as shown in time T_3 (assuming no other changes).

In a system which enables users to use a probabilistic approach, the base station would broadcast the uplink load shown in FIG. 6 to the users. At time T_1 a user can determine for itself what the probability of successful transmission would be at different transmission data rates. Certainly, a user wanting to increase its transmission data rate would determine that it would have a higher probability of success during time T_2 than at time T_1 . Using the received uplink loading information shown in FIG. 6, it is likely that a user would vary its transmission data rate with time to optimally utilize the available bandwidth.

As previously discussed, the base station could also broadcast to the user the probability of a transmission success at different multiples M (not shown in FIG. 6). The user would then decide at which multiple M to transmit.

The above-described dynamic MC-CDMA assignment schemes provide a unique means for providing a user with variable and dynamic bandwidth capacity access in a wireless network. It provides access to the "peak capacity" of a base station to a single user, without losing traditional CDMA advantages in combating multi-path impairments.

Another feature of the proposed system enables a base station to support a mobile unit population that is much greater than the number of base station receivers which, in turn, is somewhat greater than the number of simultaneous mobile transmissions supported. In such a system, we can, for instance, classify users into two groups in order to reduce the number of receivers required at the base station. For high activity factor or delay-sensitive users, dedicated receivers as well as low-rate maintenance channels could be provided at the base station. Whereas low activity factor or non-delay-sensitive users may, instead, share receiver-oriented codes for burst access requests to get a receiver ready, prior to a transmission burst.

Claims:

1. A code division multiple access radio transmitter unit comprising

5 means for receiving a digital bit stream from a user at one of a plurality of source bit rates, wherein said plurality of source bit rates includes a basic bit rate R and at least one other bit rate which is a multiple M of the basic bit rate R , where R and M are positive integers of at least 1, a user input selecting a particular user source bit rate by identifying a basic bit rate multiple M ,

10 adjustable coding means, responsive to said user input, for spreading and transmitting the user digital bit stream received at the selected bit rate to a channel bit rate which at least equals the highest bit rate of said plurality of source bit rates,

wherein said adjustable coding means includes

15 a serial-to-parallel means, responsive to a user's input identifying a basic bit rate multiple M , for converting a received user bit stream, which is M times a basic bit rate R , into M basic bit rate streams,

M encoder means for spreading each of the M basic bit rate streams, using a different spread code C , into M channel bit rate signals, and

20 means for combining the M channel bit rate signals into one channel bit rate signal and modulating the channel signal onto a carrier signal for transmission from said transmitter unit.

2. The radio transmitter unit of claim 1 wherein the user can dynamically change the selected bit rate during a transmission.

25 3. A code division multiple access radio transmitter unit comprising

30 means for receiving a digital bit stream from a user at one of a plurality of source bit rates, wherein said plurality of source bit rates includes a basic bit rate R and at least one other bit rate which is a multiple M of the basic bit rate R , where R and M are positive integers of at least 1, a user input selecting a particular user source bit rate by identifying a basic bit rate multiple M ,

adjustable coding means, responsive to said user input, for spreading and transmitting the user digital bit stream received at the selected bit rate to a channel bit rate which at least equals the highest bit rate of said plurality of source bit rates,

the radio transmitter unit further comprising
first means for requesting a communication connection over a
common access channel of a communication facility,

means for receiving a primary code C_1 , over a broadcast channel
5 of said facility, said primary code enabling said transmitter unit to transmit at the
basic bit rate R,

second means for requesting over said facility, in response to the
user input, a change in transmission rate from the basic bit rate R to a rate which
is a multiple M of the basic bit rate R, and wherein

10 said adjustable coding means changes its transmission bit rate in
response to a control signal received over said facility identifying a multiple M'
($M' \leq M$) times the basic bit rate R at which said radio transmitter unit can
transmit.

15 **4.** The radio transmitter unit of claim 3 further comprising
means for generating codes C_2 through $C_{M'}$, using said primary
code C_1 , and wherein

said adjustable coding means is responsive to the codes C_2 through
 $C_{M'}$, to enable transmitting the user digital bit stream at a multiple M' times
the basic bit rate R.

20 **5.** The radio transmitter unit of claim 4 wherein one of said codes
 C_1 through $C_{M'}$ has sub-rate capability.

6. The radio transmitter unit of claim 4 arranged to transmit at a
carrier frequency to a base station, and wherein said codes C_1 through $C_{M'}$ used
by said radio transmitter unit are different from the codes used by a second radio
25 transmitter unit which transmits to the base station at said carrier frequency.

7. The radio transmitter unit of claim 1 which communicates with
a base station over a facility and which further comprises
means for receiving an uplink control signal over the facility,
means, responsive to the uplink control signal from the base
30 station, for making a probabilistic determination of the success of the radio
transmitter unit transmitting at one or more multiples M of the basic bit rate R,
and wherein

said adjustable coding means is responsive to a determined multiple M for transmitting the user's digital bit stream at M times the basic rate R over the facility.

5 **8.** The radio transmitter unit of claim 1 which communicates with a base station over a facility and which further comprises

means for receiving a signal from the base station indicating a probability of success for transmissions at different multiples M and wherein

said adjustable coding means determines which multiple M of the basic bit rate R at which to transmit the user's digital bit stream over the facility.

10 **9.** The radio transmitter unit of claim 1 wherein

the user's digital bit stream is received as burst data and wherein said adjustable coding means transmits the burst data at a first bit rate and maintains a sub-rate signaling during a silent interval between bursts of data.

15 **10.** A method of providing code division multiple access for a radio transmitter unit, comprising the steps of

receiving a digital bit stream from a user at one of a plurality of source bit rates, wherein said plurality of source bit rates includes a basic bit rate R and at least one other bit rate which is a multiple M of the basic bit rate, where
20 R and M are positive integers of at least 1, and

in response to a user input, selecting a bit rate multiple M ,
converting a received serial user bit stream, which is M times a basic bit rate R , into M parallel basic bit rate streams,

25 spreading each of the M basic bit rate streams, using a different spread code C , into M channel bit rate signals,

combining the M channel bit rate signals into one channel bit rate signal, and

transmitting the user digital bit stream at the channel bit rate modulated onto a predefined carrier frequency.

FIG. 2

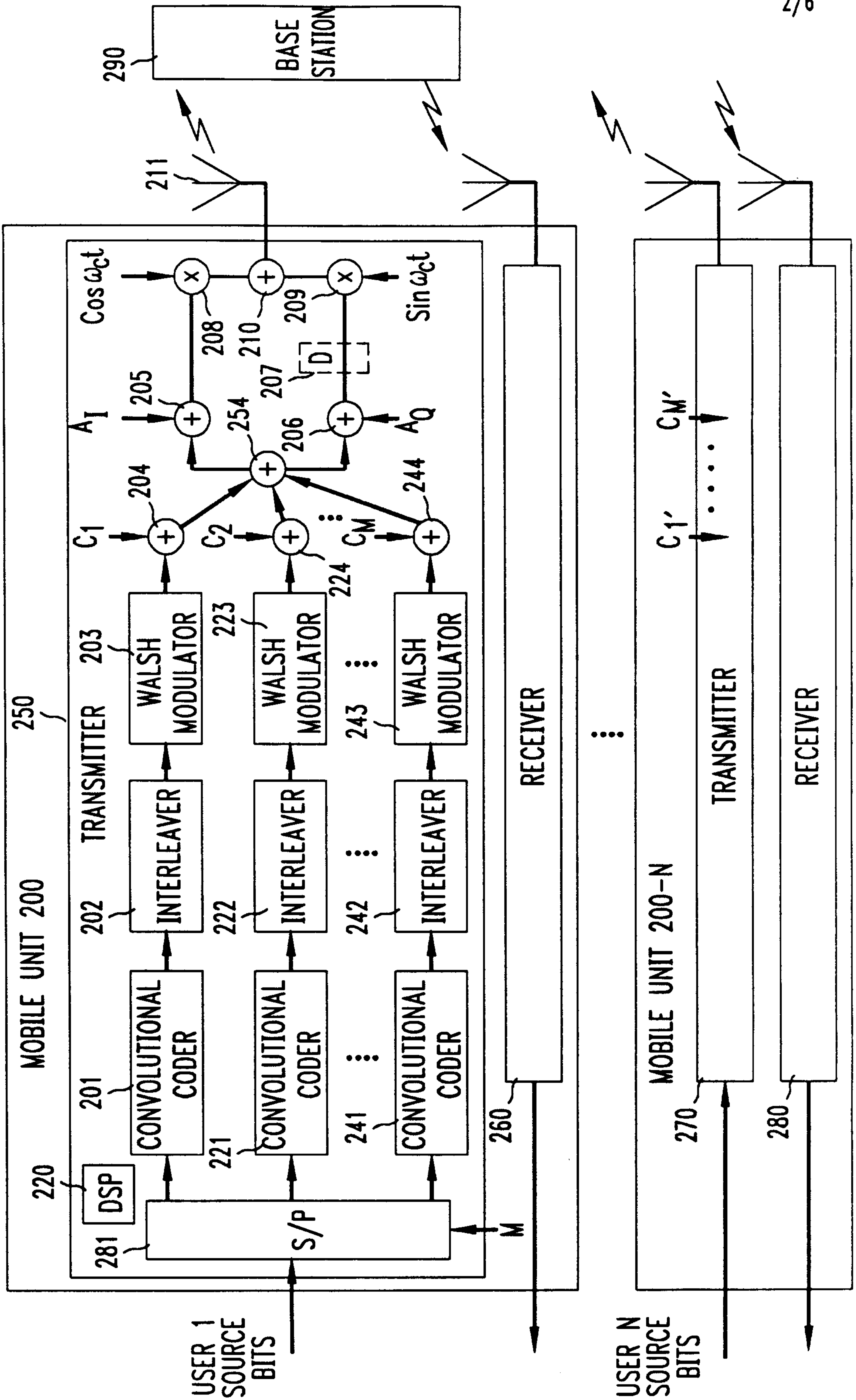

FIG. 3

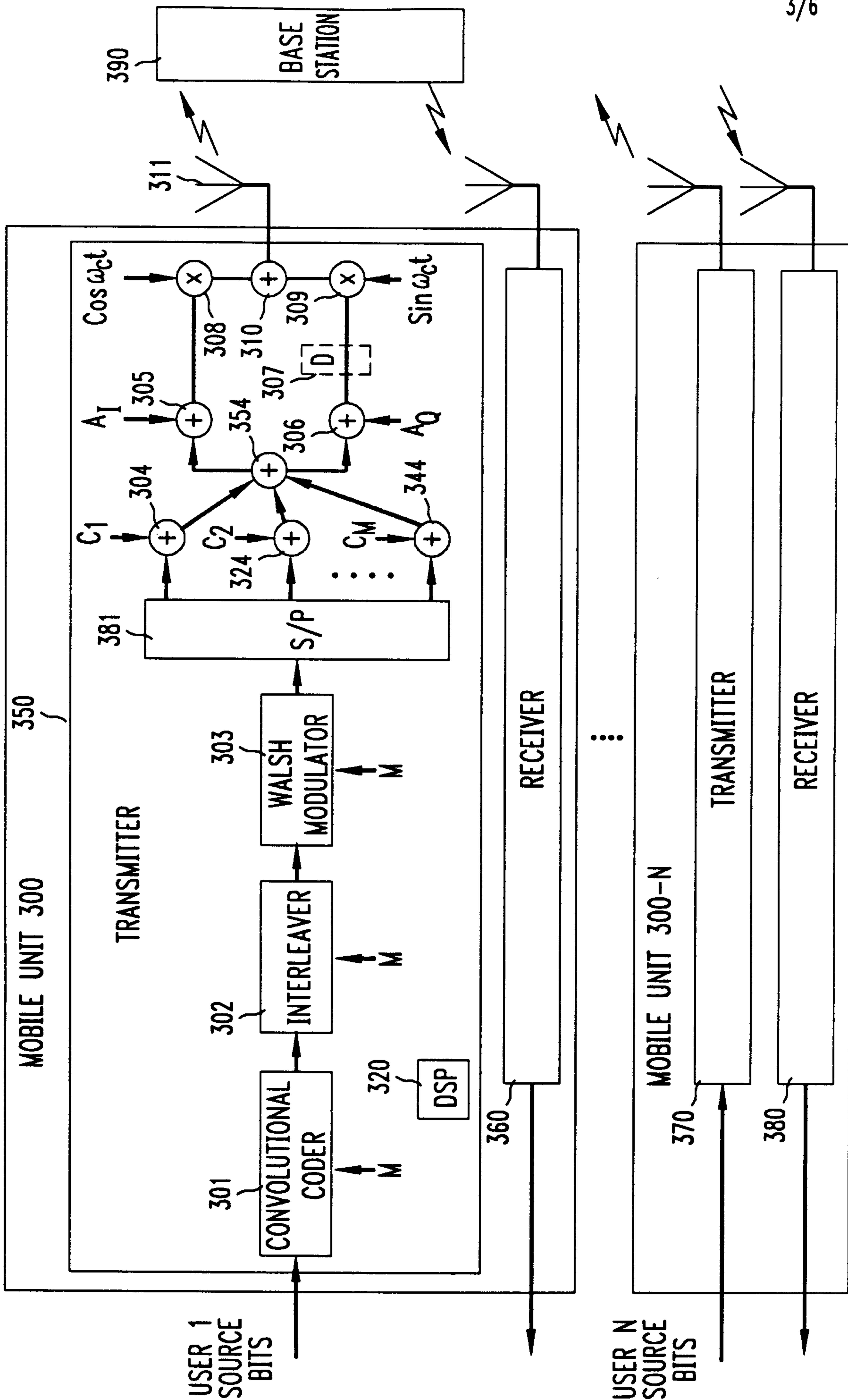

FIG. 4

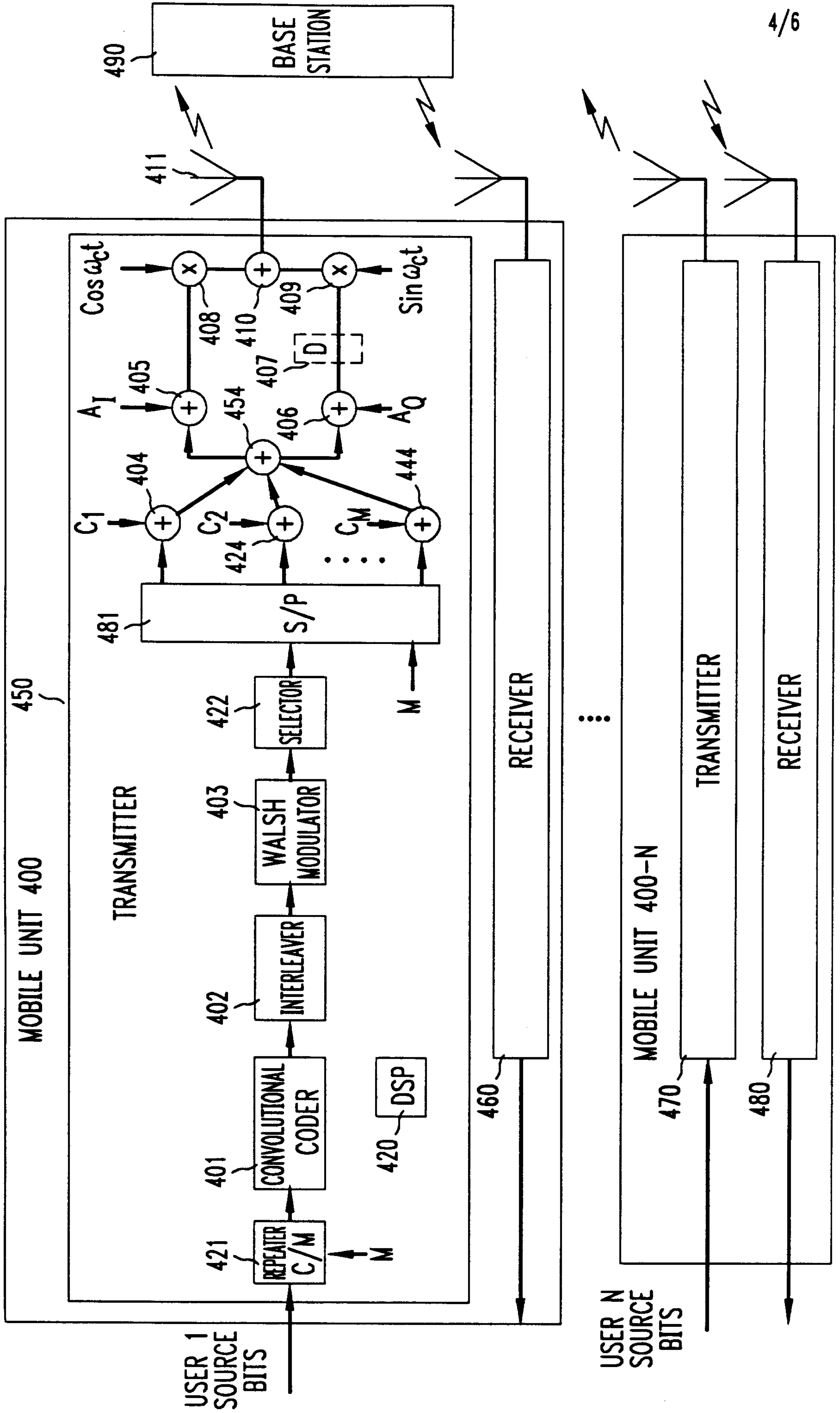

FIG. 6

