



(12) **EUROPEAN PATENT APPLICATION**

(43) Date of publication:
28.11.2007 Bulletin 2007/48

(51) Int Cl.:
E05D 3/02^(2006.01) A47L 9/00^(2006.01)

(21) Application number: **07270024.8**

(22) Date of filing: **22.05.2007**

(84) Designated Contracting States:
AT BE BG CH CY CZ DE DK EE ES FI FR GB GR HU IE IS IT LI LT LU LV MC MT NL PL PT RO SE SI SK TR

Designated Extension States:
AL BA HR MK YU

(30) Priority: **25.05.2006 GB 0610323**

(71) Applicant: **HOOVER LIMITED**
Pentrebach Road
Pentrebach
Merther Tydfil CF48 4TU (GB)

(72) Inventor: **McLeod, Euan Skinner**
Tai Po Tau Road Tai Po,
New Territories Hong Kong (CN)

(74) Representative: **Evans, Huw David Duncan**
Chapman Molony
Cardiff Business Technology Centre
Senghennydd Road
Cardiff
South Glamorgan CF24 4AY (GB)

(54) **Hinge assembly**

(57) A vacuum cleaner comprises a closure (12) having a first hinge portion (13) and body (10) having a second hinge portion (15) displaceably mounted thereon, the first portion (13) is pivotally connected to the second portion (15) for rotation of the closure (12) about a rotational axis (A-A) relative to the body (10). The vacuum cleaner further comprises an axially projecting cam (17) on the first portion (13) having a cam surface disposed radially outwardly of the rotational axis (A-A), and a fixed

abutment surface (18) disposed remote from the hinge portions (13,15). The surface of the cam (17) is biased against the abutment surface (18) by a spring (16) acting on the second hinge portion (15), the cleaner being arranged such that rotation of the first hinge portion (13) about the rotational axis (A-A) causes the cam (17) to ride over the abutment surface (18) under the applied bias allowing upward translatory movement of the rotational axis (A-A) of the closure.

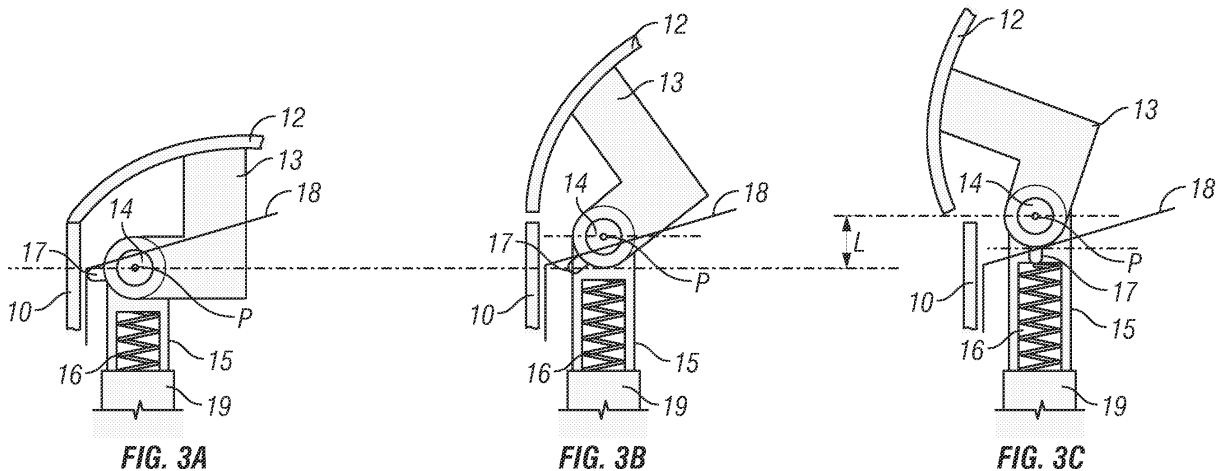

Description

[0001] This invention relates to a hinge assembly and more particularly but not solely to a hinge for a closure of a vacuum cleaner or other device.

[0002] Vacuum cleaners generally comprise an external housing, which is often provided with one or more closures that can be opened to reveal dust separation devices, such as dust bags, filters or cyclone units. The closure must be easy and convenient to open and close, in order to facilitate replacement or emptying of the dust separation device. The closure must also be capable of wide opening, so that a voluminous full dust bag can be easily removed from the cleaner.

[0003] It is also known to provide vacuum cleaners having closures, which can be opened to reveal storage compartments for cleaning tools and the like. It is desirable, for aesthetic reasons, for any such closures to be mounted flush with the housing of the cleaner, with their side edges being located in close proximity to the side edges of the surrounding portion of the housing.

[0004] The need for the closure to conform to the shape of the cleaner housing and to open widely has led to adoption of complex double-axis hinges, whereby the closure is pivotally mounted to a pair of hinge arms, the hinge arms themselves being a pivotally mounted to the body of the cleaner. A hinge arrangement of this type is disclosed in European Patent EP 0116870. It will be appreciated that the need to accommodate the hinge arms within the cleaner body makes demands on space within the body and can impose restrictions on the form and location of the bag chamber closure.

[0005] German Patent DE 4419064 discloses an alternative to double-pivot hinges, which comprises a pair of arcuate arms, rigidly attached to the bag chamber closure. The arms are a sliding fit within a pair of arcuate cavities formed in the body of the cleaner. It will be appreciated that such an arrangement imposes restrictions similar to those associated with the double-pivot arms disclosed in European Patent EP 0116870.

[0006] We have now devised a hinge assembly which alleviates the above-mentioned problems.

[0007] In accordance with the present invention, there is provided a hinge assembly comprising a first hinge portion pivotally interconnected to a displaceable second hinge portion for rotation about a rotational axis, an axially projecting cam on said first portion having a cam surface disposed radially outwardly of said rotational axis, and a fixed abutment surface disposed remote from said hinge portions, wherein the cam surface is biased against said abutment surface, the assembly being arranged such that rotation of the first hinge portion about said rotational axis causes said cam to ride over said abutment surface under the applied bias allowing translatory movement of the rotational axis.

[0008] In a vacuum cleaner, the first and second hinge portions are respectively connected to the closure and chassis thereof. As one side of the closure is opened

outwardly, the axis of rotation moves away from the body of the cleaner in a controlled manner by the action of the cam, thereby allowing space for the opposite side of the closure to move inwardly without fouling the body of the cleaner.

[0009] The hinge assembly is simple in construction and only makes small demands on space within the vacuum cleaner body. The assembly provides the functional attributes of the prior art whilst enabling the rotational axis to be located close to the extremity of the cleaner body, for example at the extreme front of a canister cleaner, without the hinge mechanism encroaching on the internal space of the cleaner.

[0010] Preferably a rotational bias is applied between said first and second hinge portions, means being provided for holding the hinge portions against said rotational bias is applied, such that when the holding means is released the rotational bias causes rotation of the first hinge portion about said rotational axis and causes said cam to ride over said abutment surface under the aforementioned applied bias allowing said translatory movement of the rotational axis.

[0011] Preferably the cam surface is biased against said abutment surface by bias means acting on said displaceable second hinge portion.

[0012] Preferably the cam is disposed at a radial distance of 5 to 15 mm away from the axis of rotation.

[0013] Preferably the cam is able to move away from the abutment surface against the spring bias in order to help avoid jamming of the assembly, for example when the closure is closed.

[0014] Preferably, at least a portion of the abutment surface is inclined relative to a plane which extends normal to the direction of the applied bias, so as to control, amplify or otherwise vary the ratio of translatory movement of the rotational axis to the angle of rotation.

[0015] Preferably, the cam comprises a projection which extends outwardly from said first hinge portion, preferably in a direction which extends axially of the axis of rotation.

[0016] Preferably, a detent is provided on the cam to retain the hinge in a particular angular configuration. The detent may comprise a planar region formed in an arcuate camming surface of the cam.

[0017] Also in accordance with this invention, there is provided a device comprising a closure having a first hinge portion and a body having a second hinge portion displaceably mounted thereon, the first portion being pivotally connected to the second portion for rotation of the closure about a rotational axis relative to the body, the device further comprising an axially projecting cam on said first portion having a cam surface disposed radially outwardly of said rotational axis, and a fixed abutment surface disposed remote from said hinge portions, wherein the cam surface is biased against said abutment surface, the device being arranged such that rotation of the first hinge portion about said rotational axis causes said cam to ride over said abutment surface under the

applied bias allowing translatory movement of the rotational axis of the closure.

[0018] Preferably a rotational bias is applied between said first and second hinge portions, means being provided for holding the hinge portions in a relative position in which said rotational bias is applied, such that when the holding means is released the rotational bias causes rotation of the first hinge portion about said rotational axis and causes said cam to ride over said abutment surface under the aforementioned applied bias allowing said translatory movement of the rotational axis.

[0019] Preferably the holding means comprises a catch which retains the closure in a closed on the body, the rotational bias preferably being applied to the closure in an opening direction such that the translatory movement occurs as the closure opens under the applied rotational bias.

[0020] Preferably the second portion is slidably mounted to the body of the cleaner.

[0021] Preferably the cam surface is biased against said abutment surface by bias means acting on said displaceable second hinge portion.

[0022] Preferably the cam surface is biased against said abutment surface in a direction which extends substantially normal to the plane of the closure when the latter is in its closed position.

[0023] Preferably the cam surface is biased against said abutment surface in a direction which extends outwardly of the body of the device.

[0024] Preferably the cam is arranged to rotate away from said closure when the closure is opened.

[0025] An embodiment of the present invention will now be described by way of an example only and with reference to the accompanying drawings, in which:

Figure 1 is a sectional view through a canister vacuum cleaner incorporating a hinge in accordance with the present invention;

Figure 2 is an exploded view of the hinge in accordance with the present invention of the vacuum cleaner of Figure 1; and

Figures 3A - 3C are schematic views illustrating the principle of operation of the hinge of Figure 2.

[0026] Referring to the drawings, there is shown the body portion 10 of a vacuum cleaner comprising an external housing of plastics material. A compartment 11 is formed inside the body 10 for receiving a dust bag (not shown) or other dust collection device, such as a porous dust box or cyclone unit. A closure 12 is provided in the upper surface of the body 10 and can be opened to allow the user to access the compartment 11, for example when changing or emptying the dust bag or other dust separation device. In order to improve the aesthetic appearance of the cleaner, the closure 12 is a flush fit with the housing of the body and the side edges thereof con-

form to the shape of the surrounding portions of the housing. The closure 12 is hinged to the body 10 of the cleaner, adjacent the front edge thereof, for rotation about a horizontal axis P. A spring (not shown) biases the closure 12 about the axis P into its open position. A catch (not shown) is provided for retaining the closure 12 in its closed position against the rotational bias.

[0027] Referring to Figure 2 of the drawings, the closure 12 is hinged to the body 10 of the cleaner by way of two depending arms e.g. 13, which extend from respective opposite ends of the lower front edge of the closure 12. The lower end of each arm 13 is turned forwardly through 90° and carries an axle 14, which projects outwardly from one side of the arm 13 in a direction which extends transversely of the cleaner and parallel to the plane of the closure 12. The axles 14 of the two arms 13 lie on a common axis A-A and are directed in respective opposite directions, transversely of the body 10 of the cleaner.

[0028] The axles 14 engage into apertures formed in respective upstanding posts 15. The lower ends of the posts 15 are captively mounted in sockets 19 formed in a chassis of the cleaner, for movement in a direction D, which extends longitudinally of the posts 15. The posts 15 are biased upwardly by respective compression springs 16.

[0029] Each arm 13 of the hinge comprises a projecting cam 17, which extends outwardly therefrom in the opposite direction to the axle 14. The cams 17 extend along an axis B-B, which extends parallel to the axis A-A of the axles 14, in a position which is offset therefrom by a distance X of between 5 and 15mm. The cams 17 are disposed on the forward side of the rotational axis A-A, whereas the closure 12 is disposed substantially on the rearward side of the rotational axis. The cams 17 are also positioned at a point which is arranged such that when the closure 12 is closed, their position with respect to the rotational axis A-A is disposed in a direction which extends substantially normal to the direction of movement of the posts 15. The axially extending sides of the cams 17 comprise arcuate camming surfaces, which face upwardly and rearwardly of the cleaner. An upwardly facing portion of the camming surfaces are generally planar.

[0030] The cams 17 each extend under an inclined abutment surface 18 formed along the underside of respective side members of the chassis of the vacuum cleaner. The abutment surfaces 18 are upwardly inclined from the front to the rear of the cleaner. The camming surfaces of the cam 17 are biased upwardly against the abutment surfaces 18 by the action of the springs 16 on the posts 15.

[0031] Referring to Figure 3A of the drawings, when the closure 12 is in its closed position, the cams 17 are biased against the lower front end of their respective abutment surfaces 18. In this position, the generally planar portions of the camming surfaces are in contact with the respective abutment surfaces 18: these portions act as detents to help keep the closure closed and to provide

some feedback feeling to the user that the closure is moving into or out of its closed position.

[0032] However, referring to Figures 3B and 3C of the drawings, when catch is released and the closure 12 moves to its open position under the applied bias, the cams 17 rotate downwardly and rearwardly in a counter clockwise direction, allowing the arms 13 of the hinge to rise under the applied spring bias. During opening, the cams 17 move upwardly along the inclined abutment surfaces 18, thereby increasing the height by which the arms 13 can rise.

[0033] It will be appreciated that the rotational axis A-A of the hinge thus rises during opening by a distance L. This height rise allows the closure 12 to open through almost 90°, yet avoids fouling of the lower front edge of the closure 12 with the body 10 of the cleaner. Accordingly, the hinge of the present invention avoids the need for an unsightly gap to be provided between the closure 12 and the body 10 of the cleaner.

Claims

1. A hinge assembly comprising a first hinge portion pivotally interconnected to a displaceable second hinge portion for rotation about a rotational axis, an axially projecting cam on said first portion having a cam surface disposed radially outwardly of said rotational axis, and a fixed abutment surface disposed remote from said hinge portions, wherein the cam surface is biased against said abutment surface, the assembly being arranged such that rotation of the first hinge portion about said rotational axis causes said cam to ride over said abutment surface under the applied bias allowing translatory movement of the rotational axis.
2. A hinge assembly as claimed in claim 1, in which a rotational bias is applied between said first and second hinge portions, means being provided for holding the hinge portions against said rotational bias is applied, such that when the holding means is released the rotational bias causes rotation of the first hinge portion about said rotational axis and causes said cam to ride over said abutment surface under the aforementioned applied bias allowing said translatory movement of the rotational axis.
3. A hinge assembly as claimed in claims 1 or 2, in which the cam surface is biased against said abutment surface by bias means acting on said displaceable second hinge portion.
4. A hinge assembly as claimed in any preceding claim, in which the cam is disposed at a radial distance of 5 to 15 mm away from the axis of rotation.
5. A hinge assembly as claimed in any preceding claim, in which the cam is able to move away from the abutment surface against the spring.
6. A hinge assembly as claimed in any preceding claim, in which at least a portion of the abutment surface is inclined relative to a plane which extends normal to the direction of the applied bias.
7. A hinge assembly as claimed in any preceding claim, in which the cam comprises a projection which extends outwardly from said first hinge portion, preferably in a direction which extends axially of the axis of rotation.
8. A device comprising a closure having a first hinge portion and a body having a second hinge portion displaceably mounted thereon, the first portion being pivotally connected to the second portion for rotation of the closure about a rotational axis relative to the body, the device further comprising an axially projecting cam on said first portion having a cam surface disposed radially outwardly of said rotational axis, and a fixed abutment surface disposed remote from said hinge portions, wherein the cam surface is biased against said abutment surface, the device being arranged such that rotation of the first hinge portion about said rotational axis causes said cam to ride over said abutment surface under the applied bias allowing translatory movement of the rotational axis of the closure.
9. A device as claimed in claim 8, in which a rotational bias is applied between said first and second hinge portions, means being provided for holding the hinge portions against said rotational bias is applied, such that when the holding means is released the rotational bias causes rotation of the first hinge portion about said rotational axis and causes said cam to ride over said abutment surface under the aforementioned applied bias allowing said translatory movement of the rotational axis.
10. A device as claimed in claim 9, in which the holding means comprises a catch which retains the closure in a closed on the body, the rotational bias preferably being applied to the closure in an opening direction such that the translatory movement occurs as the closure opens under the applied rotational bias.
11. A device as claimed in any of claims 8 to 10, in which the second portion is slidably mounted to the body of the device.
12. A device as claimed in any of claims 8 to 11, in which the cam surface is biased against said abutment surface by bias means acting on said displaceable second hinge portion.

13. A device as claimed in any of claims 8 to 12, in which the cam surface is biased against said abutment surface in a direction which extends substantially normal to the plane of the closure when the latter is in its closed position. 5
14. A device as claimed in any of claims 8 to 13, in which the cam surface is biased against said abutment surface in a direction which extends outwardly of the body of the device. 10
15. A device as claimed in any of claims 8 to 14, in which the cam is arranged to rotate inwardly of the body of the device when the closure is opened. 15
16. A device as claimed in any of claims 8 to 15, comprising dust collection means for filtering dirt and dust from an airflow and means for creating an airflow through the dust collection means. 20

25

30

35

40

45

50

55

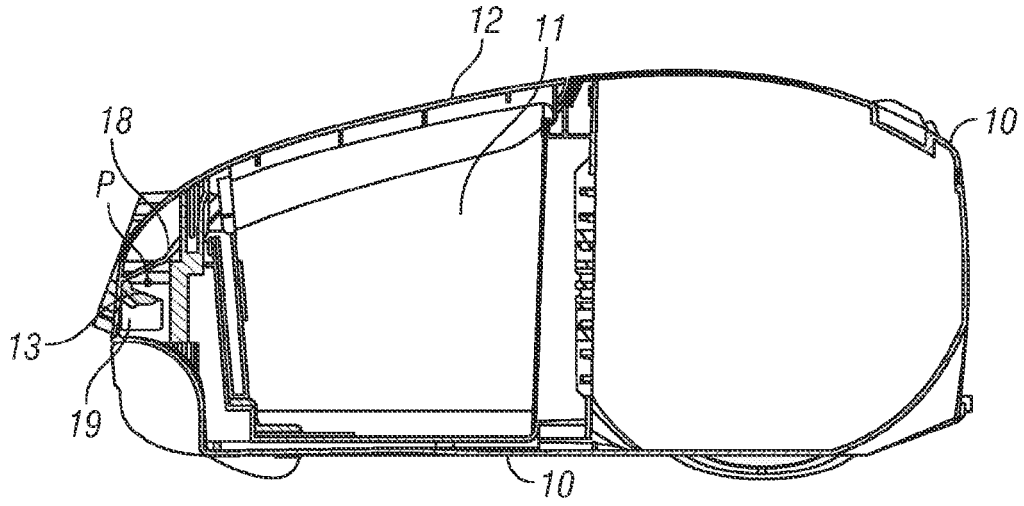

FIG. 1

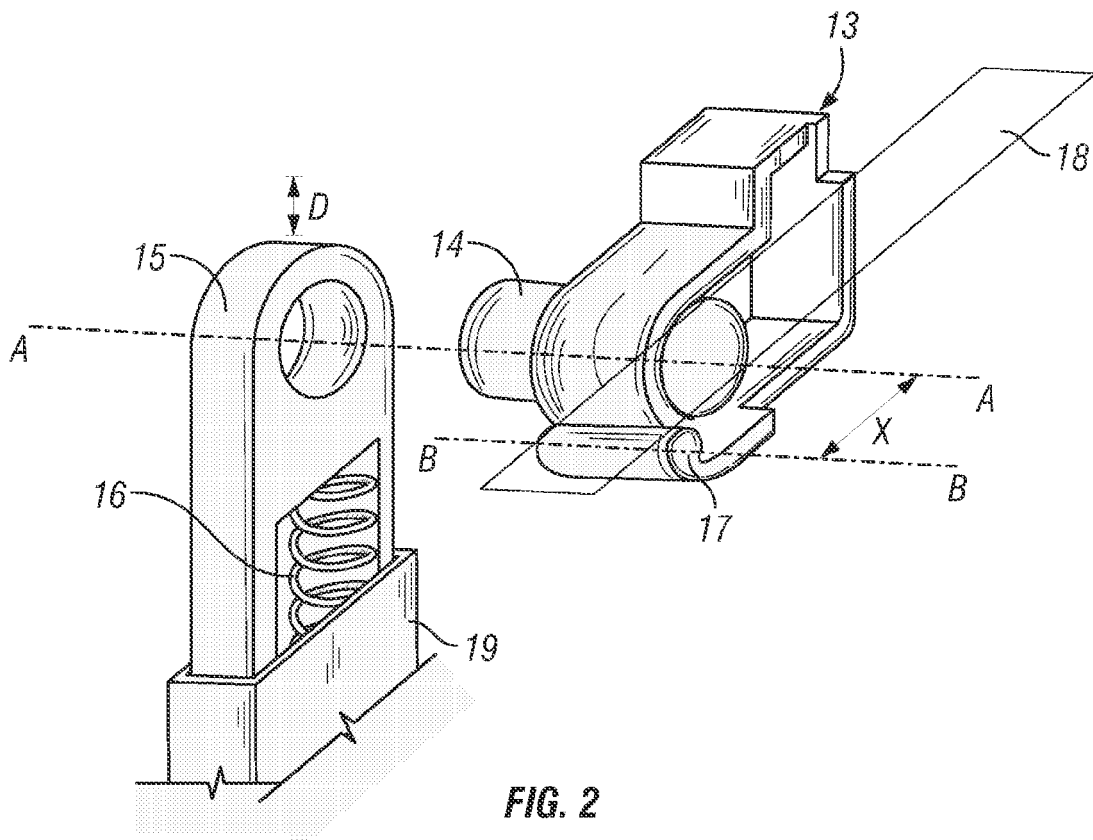

FIG. 2

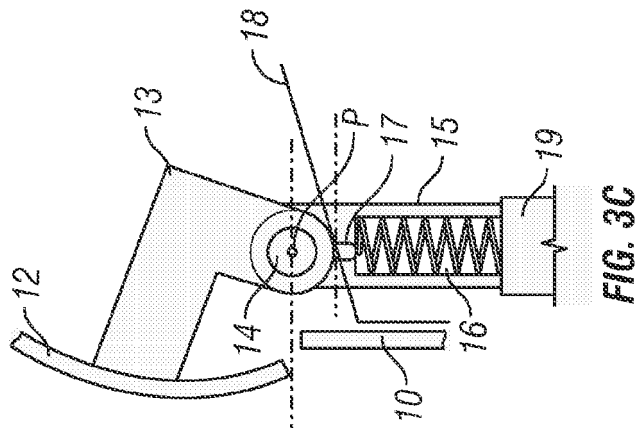

FIG. 3A

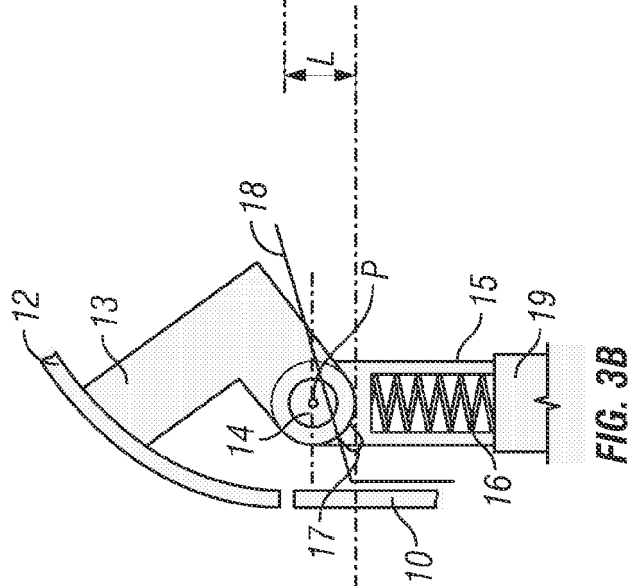

FIG. 3B

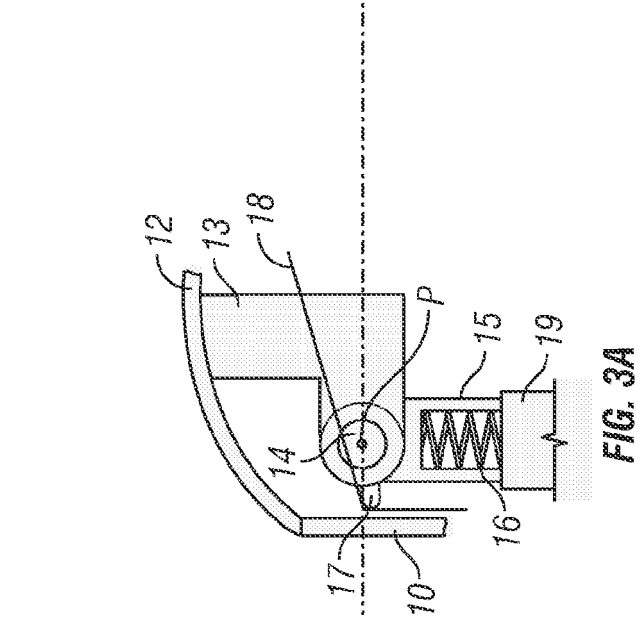

FIG. 3C

REFERENCES CITED IN THE DESCRIPTION

This list of references cited by the applicant is for the reader's convenience only. It does not form part of the European patent document. Even though great care has been taken in compiling the references, errors or omissions cannot be excluded and the EPO disclaims all liability in this regard.

Patent documents cited in the description

- EP 0116870 A [0004] [0005]
- DE 4419064 [0005]