

(19)  
(12)

(KR)  
(A)

(51) 。 Int. Cl. 7  
B23C 5/20

(11)  
(43)

2002 - 0043230  
2002 06 08

(21) 10 - 2002 - 7005067  
(22) 2002 04 19  
2002 04 19  
(86) PCT/SE2000/02029  
(86) 2000 10 19

(87)  
(87)

WO 2001/28722  
2001 04 26

(81) : , , 가 , , , , ,

(30) 9903817 - 6 1999 10 22 (SE)

(71)

- 811 81

(72)

- 81830 7

- 81151 55 1

- 81152 가 12

- 80252 가 15

- 41462 40/42

(74)

:

(54) 가

(12, 16) (1) 가 , 4 (9)  
(12)

(10) 1 (11) (12)  
 가 , 가 , 8  
 4 가 , (16) (18) 가 ,  
 (12) (11) (19) 가  
 (20) 가  
 8 가  
 7

가 , , 가  
 , , 가  
 , , 가  
 가 가

가 2  
 가 ,  
 가 , 가  
 가 , 가  
 가

가  
 TRIGON 가 4 6 가  
 egertown, PA 16433, US Greenleaf Corporation, Greenleaf Drive, Sa

, 6 4  
 , 4 가 , 90° , TRIGON 6  
 가 ,

가 가  
 (face mill)  
 가 가  
 2가  
 가 가 가  
 1  
 3497933 , 4954021 4966500 8  
 가 8 가

1 4 1  
 2 (3)가 ( )  
 가 ( (2)  
 (face mill)( )  
 8  
 10) 3 (1)가 가 가  
 1 4 가  
 2 (dowel)(6) 3  
 (axial rake angle)" 가  
 " (radial rake angle)"  
 5° 15°

7 10 (1) 가 1  
 (solid body) 8 (7)  
 (8) 가



8 가 (12, 16) , (P) (19) (P) 가  
 (3) 가 , 1 4  
 가 ,

8 (12) , (16) (P)  
 (11) 가 (14) 가 5° 15°  
 (bulge)(23) (22)가 (20)  
 (19) (24) (24) (24)  
 가 (19) (shim plate) , 4 가  
 (24) 가

8 1080°가  
 가 9  
 (11) 160° (10) ( ) 110° ,  
 , 2 (13)가 (9)  
 (9) ( 10 ) . ( ) 0.5° 5°

( )  
 , 110° 160° 120° 150° 가 가 ,  
 135°가 (overhang)  
 가 , 가  
 4 , 5 6 4 8 5  
 가 90° 2  
 " a" 가 6 8 가  
 110° 90°  
 " b" 5 4 110° 160°  
 8

(9)



15 , (11) (18)가  
 가 , 가  
 가  
 ( 11 12 ). (18)가 (11)  
 , (12b) (L) 가 , (L) ,  
 (L<sub>1</sub>)( 16 )  
 50% .

1 ( ) 가  
 ,  
 2 1 ,  
 3 ,  
 4 ,  
 5 6 4 8  
 ,  
 7 1 ,  
 8 7 ,  
 9 ,  
 10 7 9 ,  
 11 7 ,  
 12 11 ,  
 13 ,  
 14 13 ,  
 15 가 ,  
 16 9 .

(57)

1.

(7, 8) 가 가 (1) ,

(9) 가 (10) (13) 가 (P) (12) , , (16) 가 (16) 가 (face mach 가

(10) 가 8 (10, 11) 8 , 4 (11) (12) (16) 가 (18) 4 (7, 8) (11) , (P) 4 (18) (19) 가 4 , (20) 가 가 2 (18)

2.

1 , (9) ( , ) 110° 160° , 120° 150° .

3.

1 2 , 2 (12) (7, 8) (10) , (10) (13) (10) (14) 가 , (9) , (12) 가 가 (9) .

4.

1 3 , (20) , (10) 2 (18)

5.

1 4 , (18) (19) / (21) 가

6.

1 5 ,  
 (18) (19) 가

7.

1 6 ,  
 (22) (7, 8)  
 (24) 가 (23)가 (20)

8.

7 ,  
 (23) (18) (19)

9.

1 8 ,  
 (12, 16) (19) (P) 가  
 (P)

10.

1 9 ,  
 4 (18) (1)

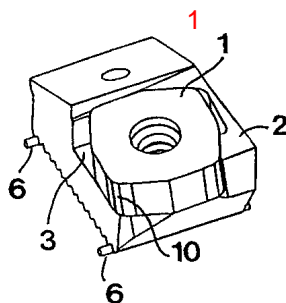

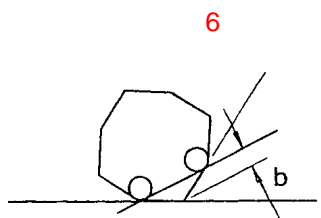
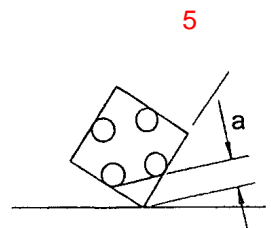
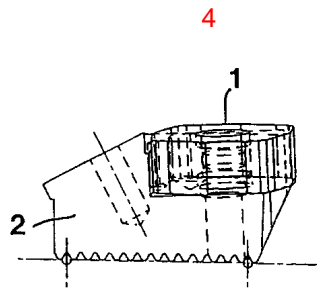
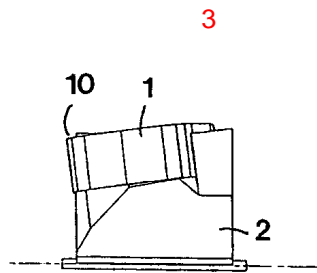
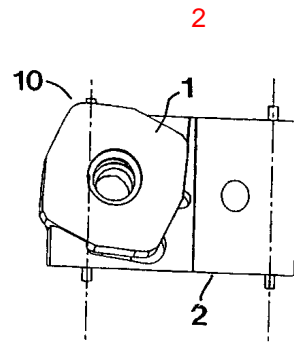

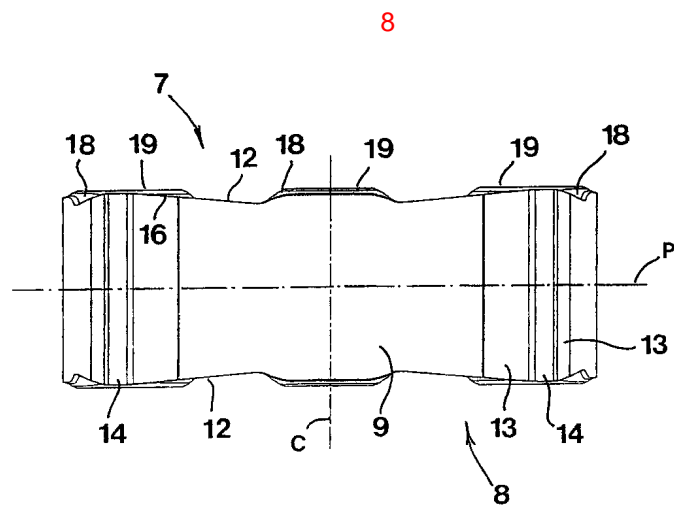
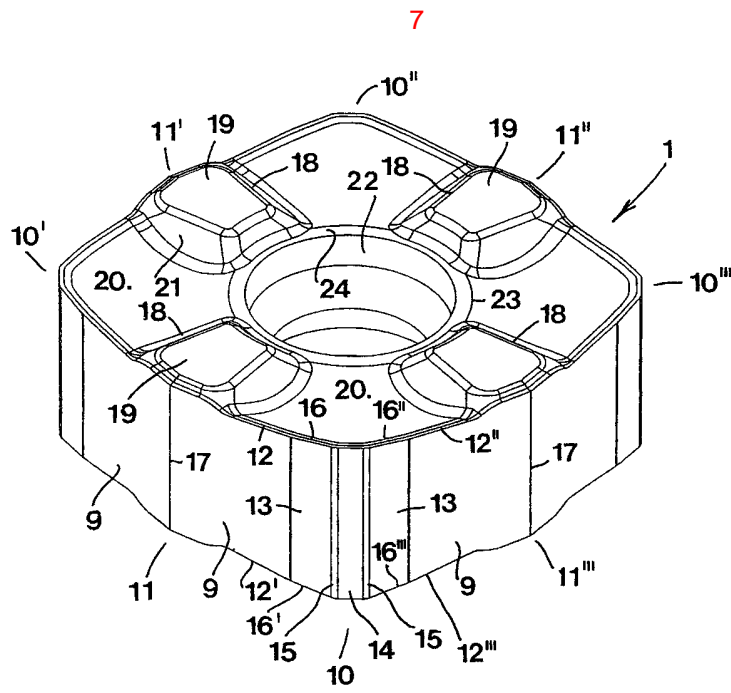



11

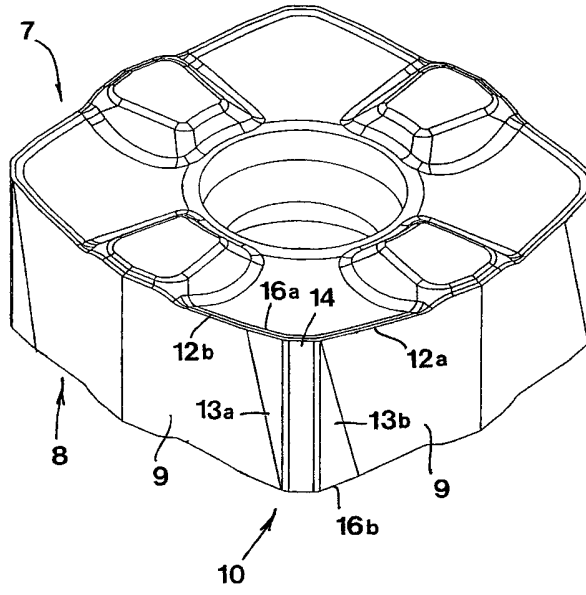

12

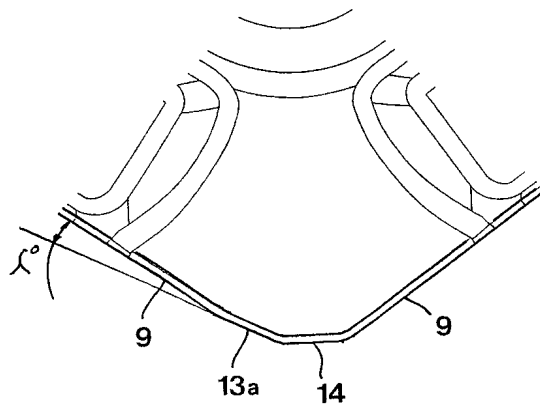

13

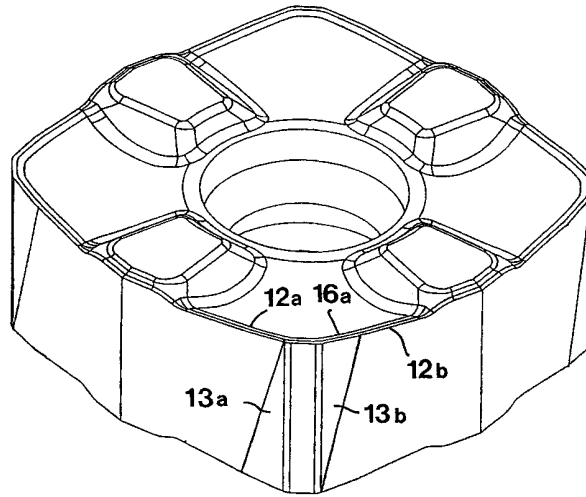

14

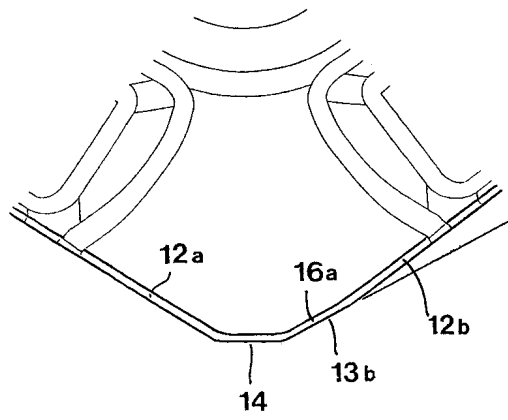

15

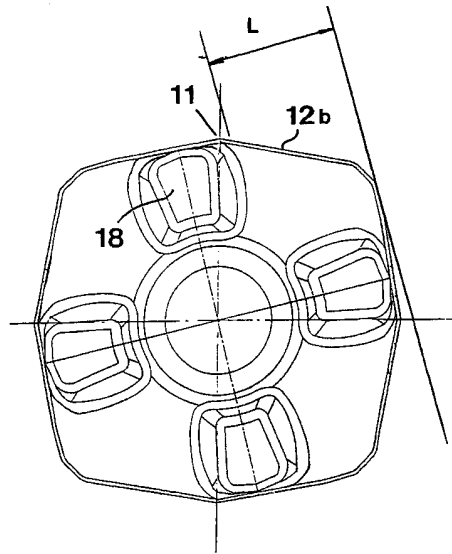

16

