

J. W. MIDDLETON.
PURIFICATION OF CAST IRON.

No. 110,666.

Patented Jan. 3, 1871.

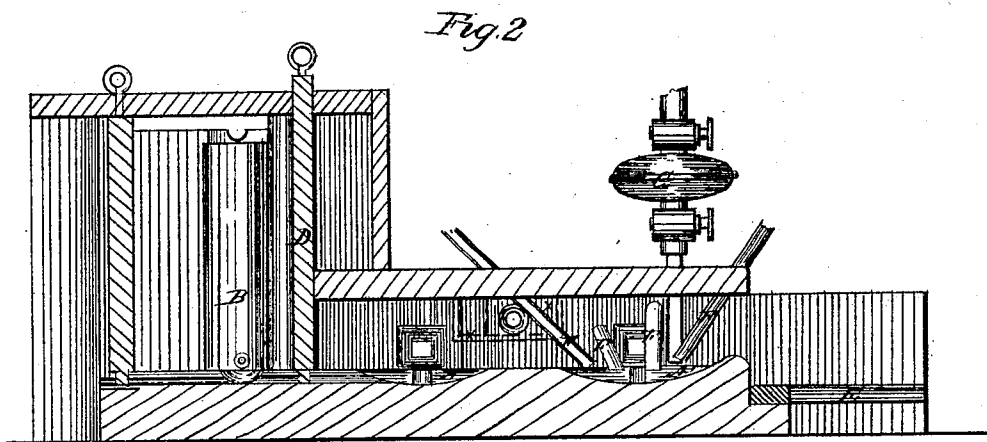
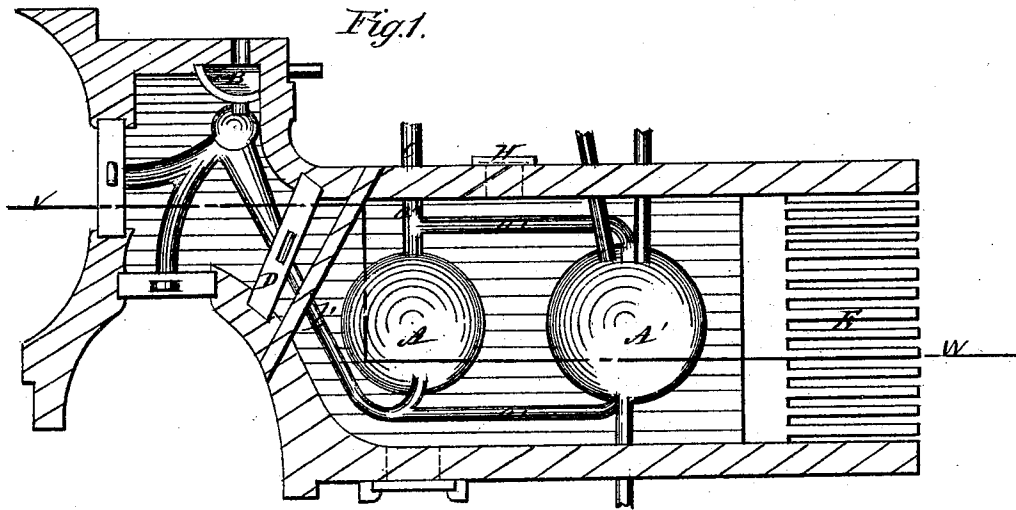

Witnesses:
Ben Morrison
Uen H. Morrison

Inventor:
John W. Middleton

United States Patent Office.

JOHN W. MIDDLETON, OF PHILADELPHIA, PENNSYLVANIA.

Letters Patent No. 110,666, dated January 3, 1871; antedated December 22, 1870.

IMPROVEMENT IN THE PURIFICATION OF CAST-IRON.

The Schedule referred to in these Letters Patent and making part of the same.

I, JOHN W. MIDDLETON, of the city of Philadelphia, in the State of Pennsylvania, have invented certain Improvements in the Purification of Cast-Iron; in partially decarburizing the same into steel; in more perfectly decarburizing the same into malleable iron, and in the apparatus therefor; of which the following is a specification.

Nature and Objects of the Invention.

The first part of my invention relates to the combination, with a puddling, boiling, or refinery-furnace, of a series of blast-pipe tuyeres, projecting downward through the top or sides, or both, of the furnace, so as to open near the surface of the melted metal in a pool or pools, in the bottom of the latter, in such a manner that hot air, superheated steam, or gas, may be driven through the said tuyeres at various angles in relation to the bottom of the furnace, into the melted metal in the pool, by a very strong or powerful blast, and in sudden powerful alternating gushes or jets from the said tuyeres; the object of this part of my invention being to produce, by means of the said powerful jets or sudden gushes, transverse interruptions of the melted mass in the pool, and other agitations, effervescings, and kneadings of the whole mass as to thoroughly expose every part of the same to the chemical and mechanical action of the said powerful jets; thus effecting in a more thorough, perfect, and expeditious manner the results obtained by the severe labor peculiar to the usual mode of puddling.

The second part of my invention relates to the application of a series of slides, of fire-brick, over suitable openings, made for the purpose through the furnace walls, for the observation of the progress of the puddling and purifying processes on the melted metal in the pool; a small opening in each of the said slides being made and closed by mica or glass, and protected against the extreme pressure of the blast, so that the window in the slide can be readily brought into juxtaposition with the opening in the wall of the furnace to afford the observation desired; and so, also, that the slide can be as readily slipped aside, so as to withdraw the mica or glass from before the opening in the wall of the furnace and thus protect it from injury by the direct heat of the furnace, without uncovering the said opening in the wall of the furnace.

The third part of my invention relates to the combination, with the puddling, boiling, or refining furnace, provided with the blast-pipes and tuyeres, previously pointed out or named, of a vertical stationary reservoir for receiving and purifying, by gravitation, melted cast-iron direct from a blast-furnace, and communicating, by an adjustable stop at its lower end

and suitable channels in the bottom of the furnace, with the pool or pools for puddling the melted metal, in such a manner that the metal, free from its lighter impurities and slag, may be run into the said pool or pools when required; the object of this part of my invention being to economise time, heat, and fuel, by making the process continuous from the blast-furnace to the completion of the same.

Description of the Accompanying Drawings.

Figure 1 is a plan view of one of a series of the furnaces, in connection with sections of two others, communicating with one and the same reservoir for supplying the impure metal to the pools, the top of the furnace being removed in order to expose the interior.

Figure 2 is a vertical longitudinal section on the dotted lines *v v* of fig. 1.

General Description.

A A' are two like pools, in the bottom of the furnace, communicating with each other and with the reservoir B, by means of channels *a a'* and *b'*, and also with the outside of the furnace by means of a channel, *a''*, and an outlet pipe of fire-brick, C.

D is a vertically-sliding gate, for opening and closing or regulating the draught through the furnace from the fire-grate E, and to shut off the furnace during the process of refining, causing the waste-heat and gas to pass under the boilers for generating steam, heating the blast, or calcining ore, and continuously passed off in that way, when refining is not going on, if heat be needed for repairs or other purposes, or to direct the escape through any suitable opening in the top of the furnace.

F F F F F are the inclined tuyeres or blast-pipes, projecting downward into the pool A', (this one only being used,) through the top and sides of the furnace.

Each of the pipes F are intended to connect with a main blast-pipe, not shown, communicating with a powerful blast-driver, in such a manner that each of the tuyeres will be fully supplied thereby.

Each of the pipes is intended to be fitted with a stop-cock, not shown, as near as practicable to the outside of the furnace, so that a very powerful blast of the hot air, superheated steam, or gas may be driven through it by sudden jets into the pool A'.

The tuyeres are arranged and directed so as to force their respective blast in transverse oblique directions into the melted mass.

The blast is intended to be caused, by suddenly opening and closing the different cocks, to enter in alternating and powerful jets, in such a manner as to produce changes and combinations of forces strik-

ing and entering the melted metal in the pool as will cause constant and powerful commotions, boilings, or effervescings in the melted mass, and thus effect the rapid decarburizing of the metal in the pool, and its refinement into steel or malleable iron, as may be desired, which result, if the heat be sufficient and the nature of the metal will permit, is intended to be run out through the gutter *a* and pipe C into hot molds, not shown, which will give it the form of ingots; but if the heat be not sufficient, or the nature of the metal be not suitable for running into ingot molds, then the tenacious mass is intended to be "balled," taken out and submitted to the "squeezer," in the usual manner of consolidating iron into blooms.

One of the windows for the observation of the progress or state of the melted metal in the pool is shown at H, the dotted line *x* in fig. 2, indicating the sliding-window plate and its guides. Several such sliding-window plates are intended to be applied to the walls of the furnace, so that an observation can be made from as many different points.

The reservoir B is a deep stationary vessel, lined inside, and protected outside by fire-brick, and provided with an outlet near its bottom, so that when the said outlet is opened the melted metal will flow therefrom into the groove leading into the pool in the bottom of the furnace.

The upper end of this vessel is intended to be a little below the hearth of the blast-furnace, not shown, so that the melted products of the said furnace may be run directly into the said vessel B, which, being kept heated, will permit the separation of the iron from the slag by gravitation.

It is intended, when expedient and desirable, to introduce by hand into the furnace solid pig-iron, or scrap-iron, to be operated upon in the said furnace in the same manner as upon the melted iron from the reservoir B.

Claims.

I claim as my invention—

1. The employment of hot air, superheated steam, or gas, directed and discharged in various places by numerous air-gun like shots or shooting gushes, of short duration, or some five hundred to fifteen hundred of suddenly-cut-off jets, into the metal in the pool of iron and slag, or of a refining, boiling, or puddling-furnace, and thus making an atmospheric kneading-like process for working out impurities, as well as decarburizing and otherwise purifying fluid-iron, substantially as and for the purpose described.

2. The combination with a puddling, boiling, or refining-furnace, of a series of the sliding-window plates H, of fire-brick, for the purpose of covering suitable openings made through the walls of the furnace, when the said sliding plates are each provided with an eye-opening, covered or closed tightly by thick glass or mica plates, so that the said glass or mica-covered opening can be brought into juxtaposition with the opening in the wall of the furnace, to afford a view of the interior, and of the pools, and tuyeres, and of the metal operated upon in the furnace, and so that the said slides can be moved back again to protect the glass or mica from injury, without allowing any of the blast to be forced out between the said slide and the wall of the furnace, substantially as described and set forth.

3. The combination with a refining, puddling, or boiling-furnace, of any form or description, of a series of pipes or tuyeres F F, projecting in downward-sloping directions, through the top or sides of the furnace or through both top and sides into the same, and communicating at their outer ends with the blast-pipe, and any sudden cut-off device to produce sudden air-gun-like shots of blast, substantially as and for the purposes hereinbefore set forth.

JOHN W. MIDDLETON.

Witnesses:

BENJ. MORISON,
WM. H. MORISON.