

(No Model.)

T. W. EVERSOLE.
SOLDERING IRON.

No. 408,408.

Patented Aug. 6, 1889.

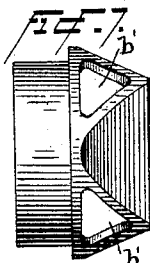
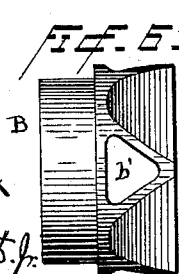
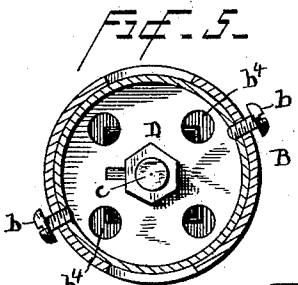
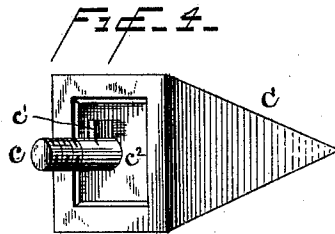
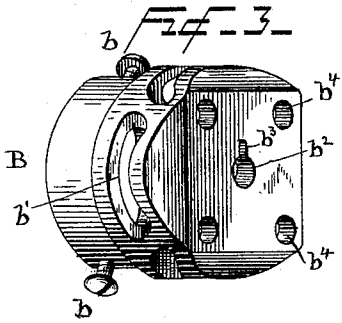
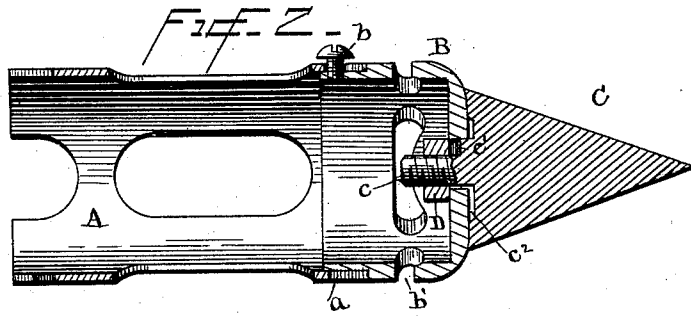
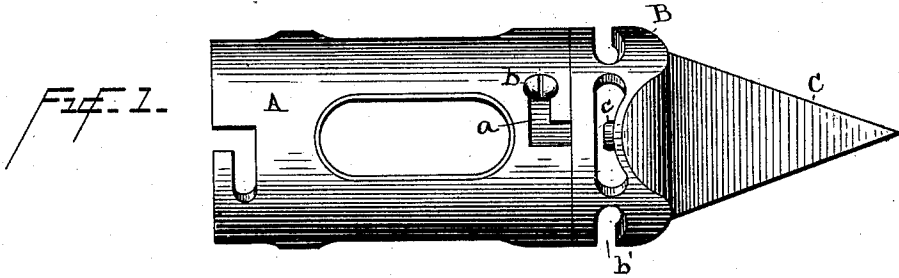

Witnesses
Norris A. Clark

Jos. C. Ringwalt, Jr.

Inventor
Theodore W. Corvode

Whittney Wright
Attorneys

UNITED STATES PATENT OFFICE.

THEODORE W. EVERSOLE, OF GARRETT, INDIANA.

SOLDERING-IRON.

SPECIFICATION forming part of Letters Patent No. 408,408, dated August 6, 1889.

Application filed January 25, 1889. Serial No. 297,495. (No model.)

To all whom it may concern:

Be it known that I, THEODORE W. EVERSOLE, a citizen of the United States, residing at Garrett, in the county of De Kalb and State of Indiana, have invented certain new and useful Improvements in Soldering-Irons; and I do declare the following to be a full, clear, and exact description of the invention, such as will enable others skilled in the art to which it ap-
10 pertains to make and use the same, reference being had to the accompanying drawings, and to the letters and figures of reference marked thereon, which form a part of this specifica-
15 tion.

My invention relates to soldering-irons, and is an improvement upon the self-heating iron shown and described in my patent, No. 388,187, dated August 21, 1888. In that pat-
20 ent the removable tip is provided with a cylindrical neck, by which it is united to the shield around the burner. The tip is deeply hollowed out, and is provided with side openings for the escape of the flame. This, however, is a difficult and expensive thing to make, and
25 I have invented the hereinafter-described im-
provement to overcome the objections to it.

In the drawings, Figure 1 is a full-sized elevation of the burner-shield, tip-holder, and tip. Fig. 2 is a longitudinal section thereof.
30 Fig. 3 is a perspective view of the tip-holder. Fig. 4 is the tip, and Fig. 5 is a sectional end view of the tip-holder and tip. Figs. 6 and 7 show a modified form of tip-holder.

The same letters indicate the same parts in
35 all the figures.

The shield A is the same as that shown in my patent above referred to, and the tip-holder B and tip C are intended to take the place of the piece lettered M in said patent.

The tip-holder B is tubular, and is closed at
40 one end. The open end fits into or outside of the shield A, and is preferably united thereto by studs *b*, entering bayonet-slots *a*. Near the closed end of the tip-holder, in that
45 portion of it that projects beyond the end of the shield A, are formed lateral openings *b'* for the escape of the flame.

The tip C is preferably pyramidal, as

shown, and is united to the holder by a thread-
ed stud *c*, projecting from its base and pass- 50
ing through a suitable hole *b²* in the end of the holder. A nut D, screwed upon the stud inside of the holder, secures the tip firmly to the holder, and a feather *c'* on the stud *c*, en-
55 gaging with a notch *b³*, formed in one side of the hole *b²*, prevents the tip from turning. The base of the tip is hollowed out around the stud *c*, forming a shallow chamber *c²*, and in the end of the tip-holder are holes *b⁴*, com-
60 municating with this chamber to give the heating-flame access to the tip. This form of tip and holder is easier to make than the one shown in the patent, and one holder serves for as many different shapes and weights of tip as may be desired. I do not limit myself
65 to the screw-threads and nut D as the means of securing the tip to the holder, since a key driven through a slot in the stud, or any other equivalent fastening, may be used.

Having thus described my invention, what I
70 claim, and desire to secure by Letters Patent, is—

1. The combination, with a tip-holder provided with a hole having a lateral notch, of a tip having a stud to enter the hole, a feather
75 to engage with the notch, and means for fastening the stud to the holder, substantially as described.

2. The combination, with the perforated shield A, of the detachable tip-holder B, closed
80 at one end and having lateral openings *b'* and end openings *b⁴*, and the tip C, detachably secured against the end of the tip-holder, substantially as described.

3. The combination, with the tip-holder B,
85 having the holes *b⁴* in its end, of the tip C, detachably secured to the holder and having a chamber *c²*, with which the holes *b⁴* communicate, substantially as described.

In testimony whereof I affix my signature in
90 presence of two witnesses.

THEODORE W. EVERSOLE.

Witnesses:

H. W. BICKNELL,
H. S. BOYD.