

Aug. 2, 1938.

A. NOVICK

2,125,308

MEANS FOR AND METHOD OF APPLYING A PATCH TO A SATCHEL BOTTOM BAG

Original Filed Aug. 2, 1934

3 Sheets-Sheet 1

Fig. 1.

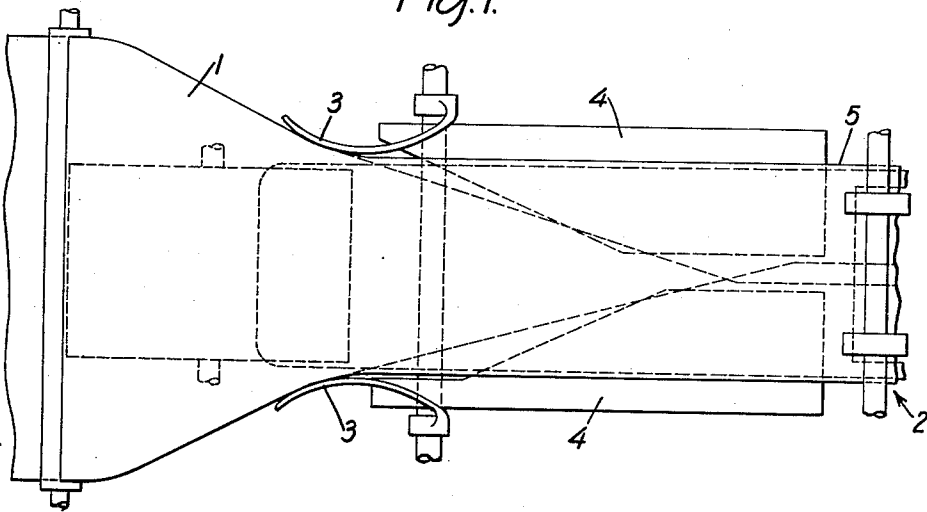
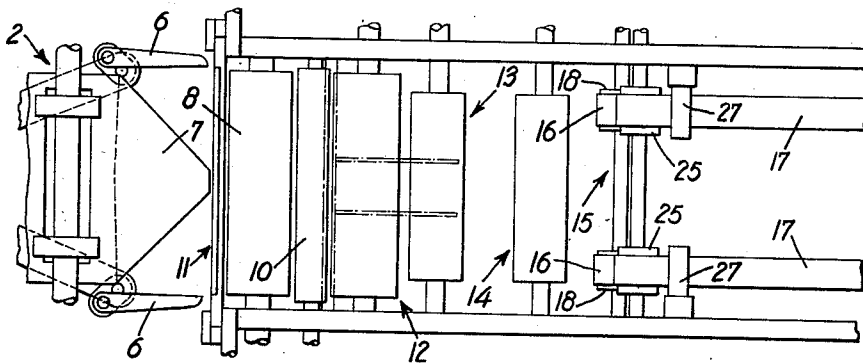

Fig. 2.



INVENTOR.
Abraham Novick.

BY *Moses & Nolta*
ATTORNEYS.

Aug. 2, 1938.

A. NOVICK

2,125,308

MEANS FOR AND METHOD OF APPLYING A PATCH TO A SATCHEL BOTTOM BAG

Original Filed Aug. 2, 1934

3 Sheets-Sheet 2

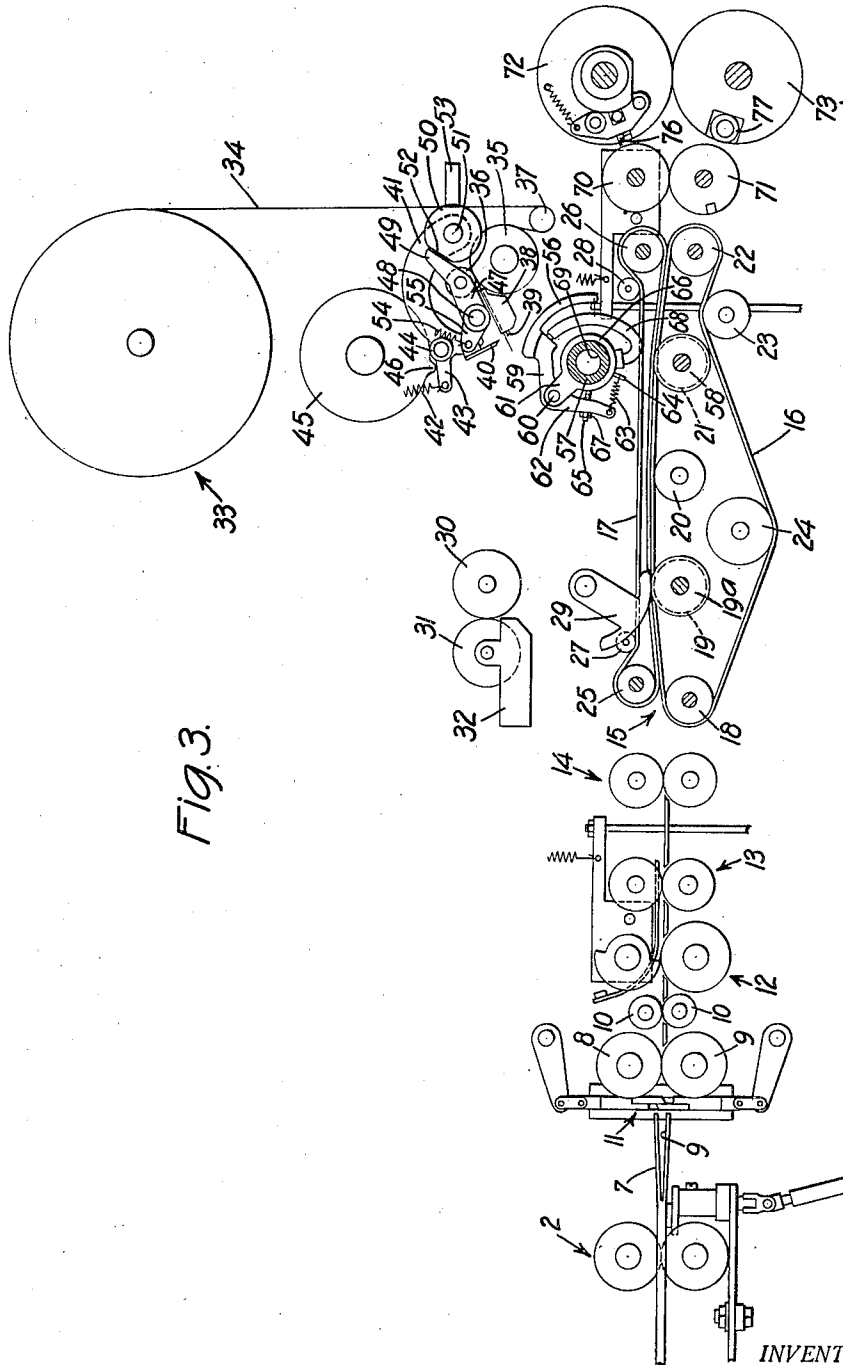

Fig. 3.

INVENTOR.
Abraham Novick.
BY *Moses & Nolte*
ATTORNEYS.

Aug. 2, 1938.

A. NOVICK

2,125,308

MEANS FOR AND METHOD OF APPLYING A PATCH TO A SACHEL BOTTOM BAG

Original Filed Aug. 2, 1934

3 Sheets-Sheet 3

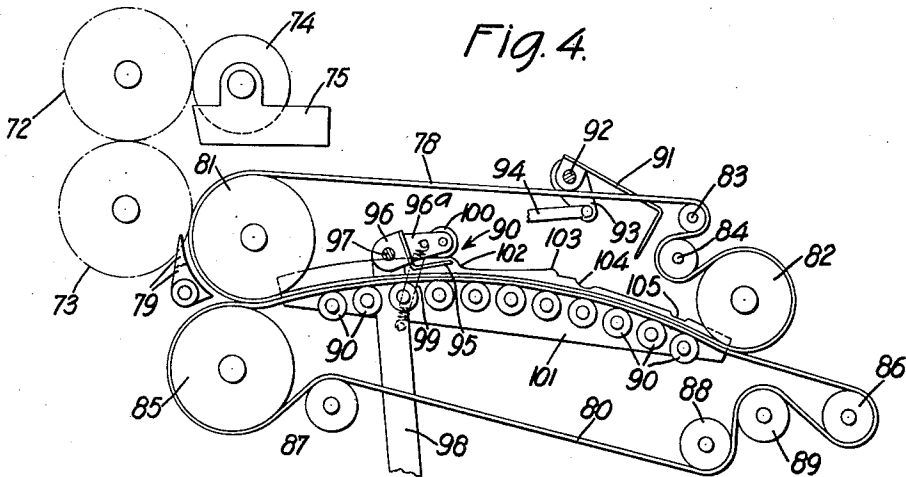

Fig. 4.

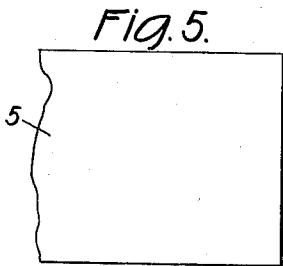

Fig. 5.

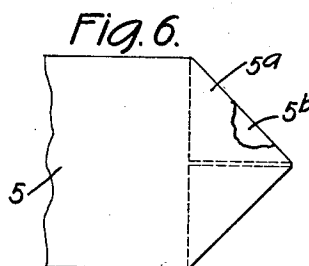

Fig. 6.

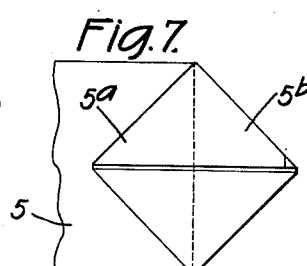

Fig. 7.

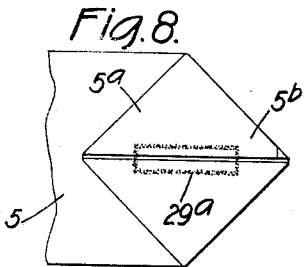

Fig. 8.

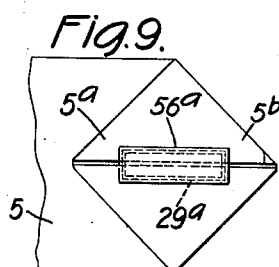

Fig. 9.

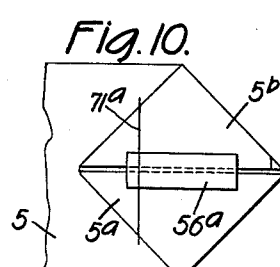

Fig. 10.

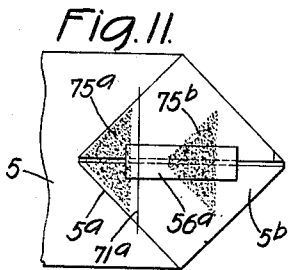

Fig. 11.

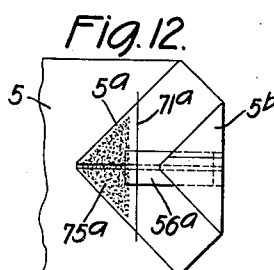

Fig. 12.

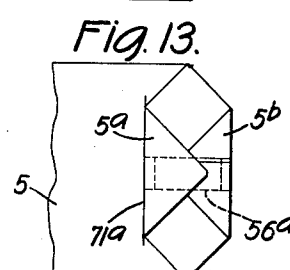

Fig. 13.

INVENTOR.
Abraham Novick.

BY *Moser + Nolte*
ATTORNEYS.

UNITED STATES PATENT OFFICE

2,125,308

MEANS FOR AND METHOD OF APPLYING A PATCH TO A SACHEL BOTTOM BAG

Abraham Novick, Flushing, N. Y., assignor to F. L. Smithe Machine Co. Inc., New York, N. Y., a corporation of New York

Application August 2, 1934, Serial No. 738,095
Renewed April 14, 1938

16 Claims. (Cl. 93—27)

This invention relates to means for and methods of applying a patch to a satchel-bottom bag.

One feature of the invention consists in the provision of means for and methods of opening out a flap of such a bag.

Another feature consists in the provision of means for and methods of applying a patch to said flaps and of so folding the flaps that the folding line will pass transversely through the patch.

A further feature consists in the provision of means for and methods of adhering each flap to the other flap and to the patch, and of adhering ends of the patch to other portions thereof.

Other features and advantages of the invention will hereinafter appear.

The bags contemplated to be made in accordance with the present invention are such as are illustrated and described in my pending application, Serial No. 715,604, filed March 15, 1934.

The invention will best be understood by reference to the accompanying drawings wherein is shown the present preferred embodiment thereof, and wherein

Fig. 1 is a fragmentary plan view illustrating mechanisms for folding a web into tubular form.

Fig. 2 is a fragmentary plan view illustrating a portion of flap-forming mechanisms, the showing at the left-hand extremity of this figure slightly overlapping the showing at the right-hand extremity of Fig. 1.

Fig. 3 is a fragmentary side elevational view illustrating tube-cutting and blank-feeding mechanisms, and flap-gumming, patch-applying and flap-folding mechanisms, the showing at the left-hand portion of this figure corresponding with the showing of Fig. 2.

Fig. 4 is a fragmentary side elevational view illustrating bag-conveying and flap-folding mechanisms, the showing at the left-hand extremity of this figure slightly overlapping the showing at the right-hand extremity of Fig. 3.

Fig. 5 is a fragmentary plan view of one end of a tube from which a bag is to be formed.

Fig. 6 is a fragmentary plan view similar to Fig. 5, but with the bag corners tucked in and folded down.

Fig. 7 is a plan view similar to Fig. 6, but with the upper flap of the bag bottom folded back upon the bag body.

Fig. 8 is a plan view similar to Fig. 7, but with areas of gum applied to the flaps.

Fig. 9 is a plan view similar to Fig. 8, but with a patch applied to the gummed areas of the flaps.

Fig. 10 is a plan view similar to Fig. 9, but with the rear flap scored to provide a folding line.

Fig. 11 is a plan view similar to Fig. 10, but with areas of gum applied to the flaps and to the patch.

Fig. 12 is a plan view similar to Fig. 11, but with the forward flap folded down upon one of the gummed areas and into adhesive contact with the patch and the bag bottom.

Fig. 13 is a plan view illustrating the completed bag bottom, the rear flap having been folded down upon and adhered to the forward flap and the patch.

Like reference characters indicate like parts throughout the drawings.

Referring to the drawings: A work web 1 (Fig. 1), which may be of "Cellophane," paper, or any other suitable bag material, is supplied from a reel (not shown). The web is drawn forward intermittently by a feeder 2 (Figs. 1, 2 and 3). It is preferable not to require the feeder 2 to draw the web directly from the reel, since such operation would necessitate that the inertia of the reel be overcome at the beginning of each feeding operation. The inertia of the reel acting in direct opposition to the feeder 2, it would be apt to cause slipping of the web relative to the feeder, with a consequent production of bags which would be defective because of being of less than desired length.

Provision may accordingly be made of mechanism, hereinafter referred to, for producing slack in the web.

Feeder 2 draws the web between guides 3 and folding plates 4 to form it into a tube 5 (Figs. 1 and 5), mechanisms (not shown) being provided for gumming one margin of the tube and adhering it to the opposite margin. After passing through feeder 2, the leading end of the tube is acted upon by two oscillating tucker blades 6 (Fig. 2), which co-operate with a bifurcated plate 7 (Fig. 3) to inwardly tuck oppositely-disposed sides of the tube, as shown in Fig. 6, in order to form an upper tab 5a and a lower tab 5b. As soon as the tucker blades are withdrawn from the path of web movement, the feeder 2 acts to advance the web the length of one blank.

Under the urge of feeder 2, the leading end of tube 5 is carried between a suction roller 8 (Figs. 2 and 3) and a roller 9, co-operative therewith. The suction roller is so constructed and arranged that it operates to raise the upper tab 5a of the leading end of the tube, while leaving the lower tab 5b free to continue along the normal path of blank movement. The leading end of the tube passes next through a pair of rollers 10 (Fig. 2), which rollers complete the folding back upon the body (Fig. 7) of the tube of the upper tab 5a

which has been raised by suction roller 8. The tube then again comes to rest, and the blank is severed from the forward end thereof by cutting mechanism 11 (Figs. 2 and 3). The severed blank is then advanced through a continuously operated feeding mechanism 12, 13 and 14 (Figs. 2 and 3), and is advanced continuously through the ensuing operations.

Referring now to Fig. 3: The severed blank, with its leading end in the form shown in Fig. 7, now passes from rollers 14 into the bight of a conveyor 15, comprising two lower belts 16 and two co-operative hold-down belts 17 (also shown in Fig. 2). Lower belts 16 run over rollers 18, 19, 20, 21 and 22, the supporting shafts of which rollers are mounted in arcuate position, in order that the belts may better grip the blank. These lower belts also run over belt-tightening rollers 23 and 24. Hold-down belts 17 run over end rollers 25 and 26, and are provided with belt-tightening rollers 27 and 28. In the course of its movement by the conveyor 15, the folded forward portion of the blank passes between bed cylinder 19a and a gum-applying segment 29, disposed between the two hold-down belts 17. This segment is periodically charged with adhesive from a gum-transfer roller 30, in peripheral contact with a gum pick-up roller 31, rotating in a body of gum in a gum pot 32. The form of this gum deposit 29a is shown in Fig. 8.

Carried by a reel 33 is a patch web 34. This web is drawn from the reel by continuously-operating feed rollers 35 and 36 and over idler roller 37. The patch material is fed onto a table 38, the forward edge of which is provided with a shearing block 39, forming one element of a patch-severing device. A blade 40 is adapted to coact with the block 39, being carried by a rocking frame 41 which is normally held up by a spring 42, connected to an ear 43 of the rocking frame and to a fixed frame member (not shown). The rocking frame is provided with a roller 44 which serves as a cam follower for engaging the periphery of a rotating cam 45. The cam 45 is of generally circular contour, but is provided with a protuberance 46 which acts upon the follower 44 to depress the rocking frame 41 at the appropriate time in the cycle of operations to cause a patch to be severed. The roller 36 is journaled in a further rocking frame 47, carried by a rock-shaft 48. One member of the rocking frame 47 is provided with a tail portion 49, which engages a disk 50. This disk 50 is rotatably mounted upon a shaft 51, and has a flat 52 close to which the tail portion 49 normally lies, thus permitting feed roller 36 normally to coact with feed roller 35. The disk 50 may be turned by means of a handle 53 to raise the tail portion 49, in order to lift feed roller 36 out of engagement with feed roller 35, thereby facilitating the threading of a new web between the feed rollers. A spring 54, connected to an arm 55 of the rocking frame 47 and to a fixed part of the machine frame, acts to urge the rocking frame 47 clockwise and hence to urge feed roller 36 toward feed roller 35.

The leading end of the web 34 which protrudes beyond the cutting block 39 extends into the path of a patch transferring and applying segment 56, which travels about a hollow shaft 57 and co-operates with a bed cylinder 58. The segment 56 travels into supporting relation to the web end, lifting it to a position where the patch web 34 is sucked against it while it is slack. The segment 56 then travels further in a counter-

clockwise direction, dragging the web over its surface and into a position where the web is taut, in which position the patch is severed from the web. The leading end of the web and the patch severed therefrom are retained in position on the segment in a manner now to be described.

Segment 56 is carried by a rocker arm 59, which is mounted upon a stud 60, on a crank 61 of the hollow shaft 57. A tail portion 62 of the rocker arm 59 is drawn toward the axis of the hollow shaft 57 by a spring 63, connected to said tail portion 62 and to a pin 64, which travels with the shaft. The tendency of the spring 63 is to project the segment 56 outward, i. e., away from the axis of the hollow shaft 57. The outward limit of movement of the segment is controlled by an adjusting screw 65, which is threaded through the tail portion 62 and which engages a hub 66 of the crank 61. A lock nut 67 is provided for maintaining the screw 65 in adjusted position. With this arrangement the segment 56 is adapted to yield when it engages the bag blank, and hence to apply the patch with light but firm and substantially uniform pressure to the blank. The arrangement disclosed does not ordinarily require resetting for operating upon blanks of different thicknesses, nor is it affected by any reasonable amount of wear.

The suction is applied through ducts (not shown), formed in the segment 56 and in the rocker arm 59. These ducts communicate through a nipple with a flexible tube 68. The tube in turn communicates through a nipple with a radial passage (not shown), formed in the wall of the hollow shaft 57. The radial passage communicates through axial passage 69 of the hollow shaft 57 with a suitable source of suction (not shown). The flexible tube 68 turns with the hollow shaft 57, and is adapted to yield to accommodate such movements of the segment 56 relative to the hollow shaft 57 as occur in the normal operation of the machine; and also such movements as may be produced by adjustment of the screw 65.

After the patch 56a is applied to a blank, the blank presents the appearance indicated in Fig. 9. It is then delivered by conveyor 15 to scoring rolls 70 and 71, which score the trailing tab of the blank in the manner indicated at 71a in Fig. 10. Upon passing between the said scoring rollers, the blank enters the bight of rollers 72 and 73. Segments of roller 72 are charged with gum by a contacting gum pick-up roller 74 (Fig. 4), which rotates in a body of gum contained in a gum pot 75. These gum segments apply two patches, 75a and 75b, of gum to the patch 29a and to the tabs 5a and 5b, as indicated in Fig. 11.

Roller 72 is also provided with a tucker blade 76, co-operative with a clamping blade (not shown), which is carried by a rock-shaft 77, mounted in the roller 73. These blades engage the leading tab 5b of the blank along a desired folding line thereof, and the blank is carried by said roller 73 into engagement with conveyor belts 78 (Fig. 4), which coact with said roller to fold the tab 5b into contact with the adjacent gummed area 75b on the patch and the bag body. The tab is thus caused to adhere in the position indicated in Fig. 12. Strippers 79 deflect the blank away from roller 73 and guide it into the bight of hold-down conveyor belts 78 and conveyor belts 80. Hold-down conveyor belts 78 marginally engage the blank; and these belts run over end rollers 81 and 82 and over belt-tightening rollers 83 and 84. Conveyor belts 80

run over end rollers 85 and 86, over belt-tightening rollers 87, 88 and 89, and over roller tables 90 of arcuate form. The blank is thus caused to travel in a curved path and is held in a curved position. The convexity of the conveyor causes the gummed portion of the unfolded tab to stand out tangent to the conveyor, and away from the body of the blank, so that the insertion is facilitated of a folding device 90.

After the blank is advanced a sufficient distance along the conveyor belts 78 and 80, a tucker blade 91 is swung down to lie momentarily in close proximity to the traveling blank. This tucker blade 91 is secured to a rock-shaft 92, which shaft is connected through a crank 93 to a thrust rod 94, in turn connected to actuating means (not shown).

Folding device 90 is operated along the path of the conveyor belts 78 and 80, to co-operate with the tucker blade 91 in folding the upper tab; and to co-operate with said conveyor in pressing the folded tab down firmly to smooth it out and to assure a good adhesive union with the patch and the bottom of the bag. The folding device comprises a folding plate 95 which is fixed upon an arm 96, secured to a rock-shaft 97. The rock-shaft is pivoted upon two oscillating arms 98, one being at each end thereof. A spring 99 is connected between one of the arms 98 and an arm 96a at one side of shaft 97, and pulls downward upon said arm. The arm 96a carries a roller 100 at the outer end thereof, which roller rides upon a cam plate 101, located adjacent the conveyor belts. The oscillating arms 98 are actuated by suitable mechanisms (not shown).

The mode of operation of the tucker blade 91 and the folding device 90 is as follows: The tucker blade is so timed that it starts from the position illustrated in Fig. 4 and moves downward and to the left until its edge engages the upstanding unfolded trailing tab of the blank. In the early period of advancement of the blank, the arms 98 lag behind so as to permit the upstanding unfolded trailing tab to reach a position definitely in advance of the plate 95. The arms 98 then sweep forward at a speed considerably greater than that at which the blank is being moved by the conveyor. When the leading edge of the plate 95 is a short distance behind the trailing end of the unfolded tab, the roller 100 drops into a depression 102 of the cam plate 101, causing the plate 95 to descend into a position almost in contact with the blank and with its forward edge substantially tangent to the conveyor. The arms 98 continue their rapid advance, inserting the plate 95 beneath the unfolded tab 5a. During this movement, the roller 100 is gradually raised in its approach to a protuberance 103 of the cam plate 101, causing the plate 95 to lift the rear end of the unfolded tab and fold it around the edge of tucker blade 91. The blade 91, however, desirably withdraws after the tab is partly folded to prevent the gummed portion 75 of the tab coming into contact with it. The roller 100 then descends into a depression 104 of cam plate 101, which causes the plate 95 to rock forward and downward as it advances, to complete the folding of the tab. At this time the plate 95 travels at about the same speed as that of the bag. This depression 104 is so deep that the full force of spring 99 is borne by the bag, so that a sharply-defined crease is produced in the tab. The arm 98 is then again swung rapidly forward to draw the plate 95 over the folded tab and iron it. The roller 100

reaches a further depression 105 of cam plate 101 before the forward edge of the newly-folded tab has come opposite the depression; and the roller is again permitted to descend to apply the full force of spring 99, through the plate 95, to the bag. The plate 95 is now caused to remain stationary in this position while the newly-folded tab of the blank is advanced beyond the depression 105. The bag, in its finished form as illustrated in Fig. 13, is then fed out by the conveyor belts 78 and 80, and the arms 98 are returned to restore the plate 95 to its original position, as illustrated in Fig. 4.

Means for actuating and controlling the web-feeding and tube-forming apparatus of Fig. 1, the flap-tucking apparatus of Figs. 2 and 3, the blank-cutting and blank-feeding apparatus of Fig. 3, the gumming and tucking elements 72 and 73 of Figs. 3 and 4, and the flap-folding and bag-conveying apparatus of Fig. 4, are illustrated, described, and claimed in my pending application, Serial No. 734,978 filed July 13, 1934.

Means for actuating and controlling the blank-conveying, flap-gumming, and patch-applying apparatus of Fig. 4, are illustrated, described, and claimed in my pending application, Serial No. 734,977, filed July 13, 1934.

It is to be understood that the embodiment of the invention herein shown and described is merely illustrative, and that, without departing from its principle, it may be embodied in other forms and structures.

I claim:

1. In a unitary apparatus of the character described, means for forming a tubular bag blank, means for folding the bottom flaps of said bag blank, means for oppositely disposing the points of said flaps, means for continuously advancing the blank, means for applying a patch to said flaps while the blank is in motion, means for folding the flaps across said patch, and means for adhering said flaps to said patch.

2. In a unitary apparatus of the character described, means for forming a tubular bag blank, means for folding and flattening the flaps of said bag blank, means for continuously advancing the blank, means for applying a patch bridging the gap between said flaps while the blank is in motion, means for folding the ends of the flaps across the patch, and means for adhering said flap folds to the patch and to each other.

3. In a unitary apparatus of the character described means for forming a tubular bag blank, means for folding and flattening the flaps of said bag blank, means for continuously advancing the blank, means for applying a patch spanning the gap between said flaps while the blank is in motion, means for folding the flaps across the patch, means for adhering one flap to the patch and to the bag bottom, and means for adhering the other flap to the patch, to said first flap, and to the bag bottom.

4. In a unitary apparatus of the character described, means for forming a tubular bag blank, means for continuously advancing said blank, means coordinated with said foregoing means for supplying a patch, means for applying said patch to the bottom flaps of the bag blank, while the blank is in motion, means for effecting folds through said patch and said flaps, and means for adhering said flaps to said patch.

5. In a unitary apparatus of the character described, means for forming a tubular bag blank, means for continuously advancing said

blank, means coordinated with said foregoing means, for supplying a patch, means for applying said patch to the bottom flaps of the bag blank while the blank is in motion, means for

5 effecting folds across the flaps and transversely across said patch, and means for adhering said flaps to said patch and to each other.

6. In apparatus of the character described, means for forming flaps in a bag blank bottom,

10 means for raising and flattening one of said flaps, and means for continuously advancing the blank, and flap-gumming, patch-applying and flap-folding devices, all acting on the traveling blank while the same is in motion.

15 7. In a bag-making machine, the combination of means for feeding a web, means for forming a tube from said web, means for inwardly tucking oppositely-disposed sides of said tube to form parallel flaps, means for severing the there-

20 by-formed blank from the tube, means for raising one of said flaps from the other flap and for pressing it back upon the body of the blank, means for applying adhesive to said flaps, means for feeding a web of patch material, means for

25 cutting a patch from said web, means for applying said patch to the gummed areas of said flaps, means for scoring a folding line across one of said flaps and said patch, means for applying adhesive to said flaps and said patch, means for

30 folding the unscored flap across said patch and into adhesive contact with said patch, means for folding the other flap along said scored line and into adhesive contact with the folded flap and the patch, and means for pressing said flaps and for delivering the thereby-formed bag.

8. The method of applying a patch to a satchel-bottom bag which consists in forming two triangular flaps in the sides of a tube, folding one of said flaps back upon the body of the tube,

40 severing a bag blank from the tube, continuously advancing the blank, adhering a patch to said flaps, while the blank is in motion to cover a portion of the gap between said flaps, folding the flaps and the patch, and adhering the flaps to the patch and to each other.

9. The method of applying patches to satchel-bottom bags which consists in forming two flaps parallel to the sides of the bag blank, folding one of said flaps back upon the blank, continu-

50 ously advancing the blank, and gumming areas of said flaps, applying a patch to said gummed areas, folding said flaps across said patch, and pressing them into adhesive contact with said patch and with each other, all while the blank

55 is in motion.

10. The method of making a patched satchel-bottom bag which consists in forming a tube from a web, inwardly tucking oppositely disposed portions of the tube to form parallel flaps, sever-

60 ing the blank from the tube, raising one of the flaps and folding it back upon the blank, gumming the flaps, applying a patch to the gummed

areas of the flaps, gumming said flaps and said patch, folding said flaps across the patch, and pressing said flaps and patch into adhesive contact with each other.

11. The continuous method of making a 5 patched satchel-bottom bag which consists in forming a tube from a web, forming flaps in the sides of a tubular blank, continuously advancing the blank, and adhering a patch to said flaps, folding said flaps across said patch, and adher-

10 ing said flaps to said patch and to each other and the ends of said patch to the portion thereof between the folding lines of the flaps and patch, all while the blank is in motion.

12. The continuous method of sealing the bot-

15 tom of a bag which consists in forming a tubular bag blank, and in forming in said bag blank two flaps one of which extends beyond the body of the blank and the other of which is folded back upon said body, continuously advancing the blank, adhering a patch to adjacent portions of

20 said flaps while the blank is in motion, gumming portions of said flaps and patch, and so folding said flaps and patch that each flap is adhered to its own flap area, to the other flap, and to the

25 patch, and the ends of the patch outside the fold lines are adhered to the portion of the patch within the fold lines.

13. The method of sealing the bottom of a bag blank which consists in continuously ad-

30 vancing the blank, forming a patch in proximity to the blank, adhering said patch to the blank bottom while the blank is in motion, and adhering portions of the bag to the patch and portions of the patch to other portions of the patch.

14. The method of making a bag which consists in forming a tube from a web, forming tri-

40 angular flaps in the sides of the tube, severing the blank from the tube, adhering a patch to the flaps, adhering a triangular portion of each flap to the patch and to the other flap, and adhering end portions of the patch to other portions thereof.

15. The method of sealing a bag bottom which consists in forming flaps in a tube, superposing

45 one flap upon the body of the tube, adhering a patch to the flaps, gumming portions of the flaps and of the patch, folding one flap to adhesively superpose a portion thereof upon the patch and a portion of the patch upon another portion

50 thereof, and folding the other flap to adhesively superpose a portion thereof upon the first flap and upon the patch and a portion of the patch upon another portion thereof.

16. The method of sealing the bottom of each 55 bag in a series of bags which comprises the steps as claimed in claim 13, and is further characterized by having the steps for making the bags and for sealing the bottoms of the several bags carried into effect continuously.

ABRAHAM NOVICK.