

ORGANISATION AFRICAINE DE LA PROPRIETE INTELLECTUELLE
(O.A.P.I.)

(10)



(11) N°

10000

(51) Int. Cl.⁶

B 66 F 11/04

B 66 F 11/00

B 66 F 15/00

(12) BREVET D'INVENTION

(21) Numéro de dépôt: 60 602

(22) Date de dépôt: 12.01.1995

(30) Priorité(s): U.S.
13.07.1992 N° 07/912,415

(24) Délivré le: 29.03.1996

(45) Publié le: 29.03.1996

(73) Titulaire(s):

- 1) MARK M. FRIEDMAN
4/9 Yahuda Halevi, 43 556 Raarana
(Israël)
- 2) MORDECHAI HAMMER (Israël)

(72) Inventeur(s):

MORDECHAI HAMMER
51A Harav Friedman,
62303 Tel Aviv (Israël)

(74) Mandataire:

Cabinet J. EKEME
B.P. 6370 - YAOUNDE (Cameroun)

(54) Titre: Extendible and retraciable device.

(57) Abrégé:

FIELD AND BACKGROUND OF THE INVENTION

The present invention relates to a device which is useful for efficiently extending and retracting a wide variety of tools and, more particularly, to a device made up of plurality of interacting members which can be easily extended and retracted so as to place in the desired location a tool or other instrumentality attached to the device.

It is often desirable to be able to place and cause to operate a tool or other instrumentality (hereinafter "tool") at a location which is more distant than can be comfortably be reached by extending one's arm with the tool therein. For example, when one wishes to change an incandescent light bulb located in a ceiling which is ten feet tall, it is necessary to grab and rotate the light bulb. To this end one might climb on a ladder and use one's hand to replace the bulb. Alternatively, one could obviate the need to use a ladder by using a sufficiently long pole which had a tool at its end which was capable of grabbing and rotating the bulb. In this case, the operator would remain standing safely on the ground while replacing the light bulb and would carry out the operation through the use of the long pole.

While a pole as described is useful in certain application, it is not free from shortcomings. Primarily, it is known that, unlike the case of replacing a light bulb described above, in many operations the location at which the operation is to take place is not at a fixed distance from the user but varies either discretely or continually during the operation.

For example, if one wished to paint the ten-foot tall walls and the ceiling of a room with paint roller, means must be at hand for locating the roller at every point on the walls and ceiling. Furthermore, the location of the roller varies instantaneously during each painting stroke, regardless of the position of the painter. One option is to use a hand-held roller and make use of a ladder or scaffolding to reach the top portions of the walls



and the ceiling. Another alternative is to mount the roller on a sufficiently long pole which will allow the top portions of the walls and the ceiling to be reached with the painter remaining standing on the floor without requiring the use of a ladder.

- 5 One disadvantage of this technique is that the length of a stroke is limited by the distance through which the painter's arms can move, i.e., if the painter is able to translate the pole a distance of three feet, the paint stroke on the wall will be limited to three feet.

A further disadvantage of this technique is that the pole is of fixed
10 length and may therefore be of limited use in other application. Thus, a five foot pole which may be useful in painting a room having ten-foot high walls and ceiling, may be largely inadequate in painting a room having fifteen-foot high walls and ceiling.

To partially overcome the latter disadvantage and to thereby increase
15 its versatility, it is possible to form the pole from a number of detachable modules. In this way modules could be added or removed before each use so as to produce a pole with overall length which is adequate for the intended task. While the modularization of the pole overcomes certain difficulties, it remains a tedious chore to add or remove modules before
20 each task. More importantly, once a pole of proper length has been assembled, it continues to suffer from the disadvantage described above relating to the limitation on the length of the stroke

A possible solution is to form a pole made up of a number of interconnected members which are able to move relative to one another and
25 thereby alternately lengthen and shorten the pole. Such a pole may use hydraulic or pneumatic means, not unlike those used in a variety of winches, for example, the system used to position a basket carrying an electrical repairman sufficiently near a transformer as to allow the repairman to work on the transformer. However, such systems are heavy
30 and mechanically complicated and are thus not suitable for a simple hand-



held pole for use in properly locating a relatively light tool.

There is thus a widely recognized need for, and it would be highly advantageous to have, an extendible-retractable device which can be actively and positively extended and retracted, as desired by the user, with the device oriented at any angle, to which a tool could be attached and which could be easily used to rapidly vary the length of the pole during the performance of a particular task.

SUMMARY OF THE INVENTION

According to the present invention there is provided an extendible-retractable device, comprising: (a) a first member; (b) a second member movable relative to the first member; (c) a first flexible connector attached to a posterior portion of the second member, the first flexible connector being constrained by and being movable relative to a first location of the first member; and (d) a second flexible connector attached to a posterior portion of the second member, the second flexible connector being constrained by and being movable relative to a second location of the first member, the second location being posterior of the first location, the first flexible connector and the second flexible connector being coupled to each other so that the first flexible connector, the second flexible connector and the second member all move simultaneously.

Also according to the present invention there is provided a extendible-retractable device, comprising: (a) a first member; (b) a second member, the first member being movable relative to the second member; (c) a third member, the third member being movable relative to the second member; (d) a flexible connector mounted in the second member, the flexible connector being connected to the first member and to the second member such that the first and third members move together in opposite directions.

According to further features in preferred embodiments of the



invention described below, there is further provided: (e) a third member movable relative to the first member and the second member; (f) a third flexible connector attached to a posterior portion of the third member, the third flexible connector being constrained by and being movable relative
5 to a first location of the second member, the third flexible connector being attached to a first attachment location of the first member so that anteriorly-directed motion of the second member results in anteriorly-directed motion of the third member; and (g) a fourth flexible connector
10 attached to a posterior portion of the third member, the fourth flexible connector being constrained by and being movable relative to a second location of the second member, the second location being posterior of the first location, the fourth flexible connector being attached to a second attachment location of the first member so that posteriorly-directed motion
15 of the second member results in posteriorly-directed motion of the third member.

According to still further features in the described preferred embodiments the members are nested together and are approximately cylindrical in shape, although the members may not be nested but rather may be arranged next to each other.

20 According to still further features in the described preferred embodiments, attached to the farthest member is a suitable tool which may be, among many other possibilities, a paint brush, a paint roller, a mop, a dust brush, a cutting tool, a tongs, or a fitting capable of attaching the device to another body.

25 According to another embodiment according to the present invention there is provided an extendible-retractable device, comprising: (a) a first member formed with a longitudinal slot; (b) a second member movable relative to the first member; (c) a rigid connector attached to a posterior portion of the second member, the rigid connector being slidable through
30 the longitudinal slot of the first member so that the second member is



moved whenever the rigid connector is moved; (d) a third member movable relative to the first member and the second member; (e) a third flexible connector attached to a posterior portion of the third member, the third flexible connector being constrained by and being movable relative to a first location of the second member, the third flexible connector being attached to a first attachment location of the first member so that anteriorly-directed motion of the second member results in anteriorly-directed motion of the third member; and (f) a fourth flexible connector attached to a posterior portion of the third member, the fourth flexible connector being constrained by and being movable relative to a second location of the second member, the second location being posterior of the first location, the fourth flexible connector being attached to a second attachment location of the first member so that posteriorly-directed motion of the second member results in posteriorly-directed motion of the third member.

According to yet another embodiment according to the present invention there is provided an extendible-retractable device, comprising: (a) a first member formed with a longitudinal slot and having a second rack; (b) a second member movable relative to the first member and having a first pinion near its anterior end and a second pinion near its posterior end, the second pinion engaged to the second rack; (c) a rigid connector attached to a posterior portion of the second member, the rigid connector being slidable through the longitudinal slot of the first member so that the second member is moved whenever the rigid connector is moved; (d) a third member movable relative to the first member and the second member, the third member having a first rack engaged to the first pinion, the pinion being rotatable by a cable which is attached to the first member so that anteriorly-directed motion of the second member results in anteriorly-directed motion of the third member, the third member being attached to a second pinion cable for rotating the second pinion, so that posteriorly-

6
directed motion of the second member results in posteriorly-directed motion of the third member.

The present invention successfully addresses the shortcomings of the presently known configurations by providing an extendible-retractable
5 device on which can be mounted a suitable tool which can be used to continually change the position of the tool so as to facilitate carrying out the task.

BRIEF DESCRIPTION OF THE DRAWINGS

The invention is herein described, by way of example only, with
10 reference to the accompanying drawings, wherein:

FIG. 1 is a device made up of three members;

FIG. 2 is another device made up of two members and featuring a detachable handle;

FIG. 3 is yet another device made up of two members and featuring
15 a rigid connector;

FIG. 4 is a device made up of three members which are arranged next to each other rather than inside one another as in Figure 1;

FIG. 5 is still another embodiment of a device according to the present invention featuring three members, a rigid connector and rack-and-
20 pinion mechanisms;

FIG. 6 is a variation of the embodiment of Figure 5 featuring a motor, a gear wheel and a notched bar;

FIG. 7 is an embodiment similar to that of Figure 1 but with a motor for moving the second member;

25 FIG. 8 is an alternative embodiment including detachable extension members;

FIG. 9 is another alternative embodiment featuring a single toothed wheel;

FIG. 10 is an embodiment similar to that of Figure 9 but featuring



a pair of connected toothed wheels;

FIG. 11 shows another embodiment according to the present invention;

FIG. 12 shows a magnified section of the embodiment of Figure 11 and further shows a flexible connecting member;

FIG. 13 shows a typical device according to the present invention with a selection of tools for attachment to the device;

FIGS. 14A and 14B show a device according to the present invention in use for painting a vertical wall;

FIG. 15A and 15B show a device according to the present invention in use for sweeping a floor;

FIG. 16 shows a number of interlinked devices according to the present invention;

FIG. 17A and 17B show a number of interlinked devices according to the present invention when used to create a support structure of suitable dimensions;

FIG. 18A and 18B illustrate two tripods incorporating devices according to the present invention;

FIG. 19A and 19B illustrate two more tripods incorporating devices according to the present invention;

FIG. 20A, 20B and 20C illustrates three additional applications of a device according to the present invention using an electrical shocker.

DESCRIPTION OF THE PREFERRED EMBODIMENTS

The present invention is of a device which can be used to continually change the position of a tool during the operation of the tool. Specifically, the present invention can be used to conveniently and rapidly carry out a large variety of tasks which would otherwise require careful preparation and/or the use of ladders and similar devices. For example, a device according to the present invention can be used to quickly and safely



paint entire walls and ceilings while standing on the floor. It can be used to replace light bulbs in the ceiling without having to climb on a ladder or touch the bulb. It can be used to take down a book or a grocery store item located on a high shelf without use of a chair or a ladder.

5 The principles and operation of an extendible-retractable device according to the present invention may be better understood with reference to the drawings and the accompanying description.

Referring now to the drawing, Figures 1 and 2 illustrate two related embodiments of the present invention. The device illustrated includes three
10 members -- a first member 10, a second member 12 and a third member 14. The three members are sized and shaped so as that third member 14 fits inside second member 12 which, in turn, fits inside first member 10. Second member 12 and third member 14 are movable parallel to each other and relative to first member 10. The members shown are cylindrical in
15 shape, but any other suitable shape may be used. For example, a system according to the present invention may include a member of square cross section nested within a member of circular cross section. This facilitates the prevention of rotation of one member relative to another. In certain applications, however, it may be desirable to have one member rotate
20 relative to another, either automatically as part of the extension or retraction process (e.g. with the aid of a spiral protrusion on the outside surface of an inner member) or independently controlled by the user. It is not essential that the three members be nested inside each other as will be discussed below in the context of Figure 4.

25 A first flexible connector 16, which is preferably a suitable cable, is attached to second member 12, preferably at its posterior portion, most preferably at its posterior edge. The attachment is preferably permanent. First flexible connector 16 then runs from its point of attachment to second member 12 to the adjoining anterior edge 18 of first member 10. It is
30 preferable to include a small pulley wheel (not shown) permanently



attached to first member 10 at anterior edge 18 to facilitate movement of first flexible connector 16 and prevent friction and wear of first flexible connector 16. From there, first flexible connector 16 runs posteriorly along the wall of first member 10. Rather than passing over the anterior edge 18 of first member 10, first flexible connector 16 may be made to pass through a first hole 20 (Figure 2), preferably located near the anterior edge 18 of first member 10, which may, itself include a friction-reducing pulley. In either case, first flexible connector 16 is made to pass through a fixed point on first member 10, preferably located at or near anterior edge 18 of first member 10.

A second flexible connector 22, which is preferably a suitable cable, is also attached to second member 12, preferably at its posterior portion, most preferably at its posterior edge. The attachment is preferably permanent. Second flexible connector 22 then runs from its point of attachment to second member 12 to the adjoining posterior edge 24 of first member 10. It is preferable to include a small pulley wheel (not shown) permanently attached to first member 10 at posterior edge 24 to facilitate movement of second flexible connector 22 and prevent friction and wear of second flexible connector 22. From there, second flexible connector 22 runs anteriorly along the wall of first member 10. Rather than passing under the posterior edge 24 of first member 10, second flexible connector 24 may be made to pass through a second hole 26 (Figure 2), which is posterior of first hole 20 and which is preferably located near the posterior edge 24 of first member 10, which may, itself include a friction-reducing pulley. In either case, second flexible connector 24 is made to pass through a fixed point on first member 10, preferably located at or near posterior edge 24 of first member 10.

The end of first flexible connector 16 and the end of second flexible connector 22 which are not connected to second member 12 are coupled to each other either directly or indirectly. When coupled directly to each



other the two flexible connectors in form, in effect, a single flexible connector. Operation of the device in this case is by alternatively pulling the joined flexible connector anteriorly and posteriorly. Rather than joining the ends of the two flexible connectors, it is clear that it is possible to use
5 a single flexible connector from the start and thereby obviate the need to attach to each other two connectors. Similarly, it is clear that two flexible connectors attached to second member 12 may alternatively be a single connector which is attached to second member 12.

Alternatively, the two ends of flexible connectors 16 and 22 are each
10 attached to opposite ends of a handle 28. Alternatively, a handle 28 may be mounted onto and fixedly connected to a single flexible connector. Flexible connectors 16 and 22 are sufficiently taut that longitudinal motion of handle 28 translates into longitudinal motion in the opposite direction of second member 12. To facilitate use of the device it may be desirable
15 to include a secondary handle (not shown) fixedly connected to first member 10. This secondary handle, which may extend posteriorly from first member 10, or which may form the posterior portion of first member 10, would be intended as a place for the user's other hand, i.e., the hand not used to operate handle 28, to firmly grasp the device and help create
20 the relative motion between handle 28 and first member 10.

Handle 28 may be of any suitable design. In the embodiment of Figure 1, handle 28 hangs on the side of first member 10. In a preferred embodiment shown in Figure 2, handle 28 is equipped with means for attaching handle 28 to first member 10. Such means may take the form of
25 a protrusion 38 in the surface of handle 28 facing first member 10. Protrusion 38 is sized and shaped so as to fit within one or a series of depressions 40 in the side of first member 10. This mechanism makes it possible to fix the position of handle 28 once the desired extension or retraction has been achieved, and prevents the extent of the extension or
30 retraction from accidentally changing.



In an alternative embodiment according to the present invention, handle 28 is replaced by a winch mechanism (not shown) which is permanently attached to first member 10. Rather than pulling handle 28 anteriorly or posteriorly, the winch is turned to accomplish the same goal.

5 The winch may further include means, such as ratchet mechanism, for locking the winch in a particular position so as to prevent the members from moving relative to each other.

In the preferred embodiment of Figure 1, third member 14 is connected to first member 10 through a third flexible connector 30 and a
10 fourth flexible connector 32.

Third flexible connector 30, which is preferably a suitable cable, is attached to third member 14, preferably at its posterior portion, most preferably at its posterior edge. The attachment is preferably permanent. Third flexible connector 30 then runs from its point of attachment to third
15 member 14 to the adjoining anterior edge 34 of second member 12. It is preferable to include a small pulley wheel (not shown) permanently attached to second member 12 at anterior edge 34 to facilitate movement of third flexible connector 30 and prevent friction and wear of third flexible connector 30. From there, third flexible connector 30 runs
20 posteriorly along the wall of second member 12. Rather than passing over the anterior edge 34 of second member 12, third flexible connector 30 may be made to pass through a third hole (not shown), preferably located near the anterior edge 34 of second member 12. In either case, third flexible connector 30 is made to pass through a fixed point on second member 12,
25 preferably located at or near anterior edge 34 of second member 12. The end of third flexible connector 30 is attached to a fixed point, preferably at or near the anterior edge of first member 10, and preferably permanently, in such a way that third flexible connector 30 is always taut so that anteriorly-directed motion of second member 12 results in
30 anteriorly-directed motion of third member 14.



A fourth flexible connector 32, which is preferably a suitable cable, is also attached to third member 14, preferably at its posterior portion, most preferably at its posterior edge. The attachment is preferably permanent. Fourth flexible connector 32 then runs from its point of attachment to third member 14 to the adjoining posterior edge 36 of second member 12. It is preferable to include a small pulley wheel (not shown) permanently attached to second member 12 at posterior edge 36 to facilitate movement of fourth flexible connector 32 and prevent friction and wear of fourth flexible connector 32. From there, fourth flexible connector 32 runs anteriorly along the wall of second member 12. Rather than passing under the posterior edge 36 of second member 12, fourth flexible connector 32 may be made to pass through a fourth hole (not shown), which is posterior of third hole described above and which is preferably located near the posterior edge 36 of second member 12. The end of fourth flexible connector 32 is attached to a fixed point, preferably at or near the anterior edge of first member 10, and preferably permanently, in such a way that fourth flexible connector 32 is always taut so that anteriorly-directed motion of second member 12 results in anteriorly-directed motion of third member 14. Preferably, third flexible connector 30 and fourth flexible connector 32 are connected to third member 14 at opposing points along its circumference. Similarly, third flexible connector 30 and fourth flexible connector 32 are preferably connected to first member 10 at opposing points along its circumference. Such placement of the attachment points serves to centralize third member 14 and reduce its tendency to engage the walls of second member 12 and produce undesirable frictional forces which tend to impede relative motion of the members. The centralization thus serves to facilitate the extension and retraction of the device. Toward the same ends, it may be preferable to include a number of connected or independent third flexible connectors 30 and/or a number of connected or independent fourth flexible connectors 32 disposed around the periphery of



third member 14 to further centralize third member 14. Along the same lines, it may be preferably to utilize a number of connected or independent first flexible connectors 16 and/or a number of connected or independent second flexible connectors 22 disposed around the periphery of first member 10 to further stabilize and centralize second member 12.

A device according to the present invention may be used to carry a tool and place it where the user desires as the task being performed progresses. The variety of tools which can be used in conjunction with an extendible-retractable device according to the present invention is almost limitless. For convenience, they can be classified into passive tools, automatically activated tools, and independently activated tools. In each case, the tool is preferably connected, most preferably detachably, to the furthest member of the device.

Passive tools include those tools which need merely be connected to the furthest member. In this category fall tools such as a paint brush, a paint roller, a mop, a dust brush, a stationary cutting tool, such as a knife. Also included in this category are various fittings which make it possible to connect the device to another body. For example, the tool could be used as a tripod to support a camera, or as a support for an antenna, or as a bolt onto which a shading member can be screwed to form a beach umbrella. Similarly, the fitting 42 may be such as to make possible the attachment of a second extendible-retractable device, as through an engageable opening 43, which would make it possible to quickly build rigid structures such as a tent.

Automatically activated tools are those which would be activated and deactivated by the very extension or retraction of the extendible-retractable device. For example, in picking fruits which are all at approximately the same height from the ground, it may be desirable to use a clipper which closes and cuts whenever the extendible-retractable device is extended.



Finally, independently activated tools are those which can be activated or operated by the user independently of the current extension or retraction status of the device. Examples might be various cutting tools, shears, scissors, and tongs 44 used to pick up and release various objects.

5 To operate such tools means would be provided to transmit an independent action by the user to the tool. One such means might be a coaxial cable configuration, such as is used in braking systems for bicycles. Sufficient coaxial cable 46 would be wound on a roller so that the cable could be automatically lengthened and shortened as the device is lengthened and

10 shortened. The coaxial construction of the cable, with the inner cable being able to move relative to the outside tube, would allow the user to operate the tool regardless of the precise extension or retraction status of the device. To operate the tool, the user would move an operating handle 48.

15 Handle 48 may be of any suitable construction. One example of handle 48 is shown in Figure 5 wherein handle frame 70 is rigidly mounted to first member 10. Handle bar 72 is slidably mounted onto handle frame 70 so that the user can pull handle bar 72 toward handle frame 70 whenever it is desired to activate, for example, tongs 44. Preferably,

20 handle bar 72 is biased, as by a spring (not shown) to a position away from handle frame 70. Onto handle bar 72 is mounted a spool 74 onto which is wound an appropriate length of cable 46 to accommodate the varying lengths of the device in various states of extension and retraction.

Another alternative configuration is shown in Figure 3. Here first

25 member 10 features a longitudinal slot 50. A rigid connector 52 is attached to a posterior portion of second member 12. Rigid connector 52 is slidable through longitudinal slot 50 so that second member 12 is moved whenever rigid connector 52 is moved. Rigid connector 52 may be attached to or may include a handle element 54 which is found outside of

30 first member 10. To extend or retract the device, the user would move



handle element 54 anteriorly or posteriorly, respectively. Such a mechanism replaces first flexible connector 16 and second flexible connector 22. The interconnections represented by third flexible connector 30 and fourth flexible connector 32 are as described above in the context
5 of the previously discussed embodiments.

Yet another alternative embodiment of a device according to the present invention is shown in Figure 4. The device is related to that shown in Figure 1, except that rather than the three members being nested inside one another, the three members of Figure 4 are arranged along side of each
10 other. Such a configuration may be useful, for example, in opening and closing slats of window blinds of various types. The slats may move through tracks or may be suspended.

Still another alternative configuration is shown in Figure 5. Here, as in the embodiment shown in Figure 3, first member 10 features a
15 longitudinal slot 50. A rigid connector 52 is attached to a posterior portion of second member 12. Rigid connector 52 is slidable through longitudinal slot 50 so that second member 12 is moved whenever rigid connector 52 is moved. Rigid connector 52 may be attached to or may include a handle element 54 which is found outside of first member 10. To extend or
20 retract the device, the user moves handle element 54 anteriorly or posteriorly, respectively. Handle element 54 may include handle stopper 55 which can be inserted into longitudinal slot 50 whenever it is desired to immobile handle element 54 so as to maintain a certain degree of extension or retraction of the device.

25 Attached to first member 10 is a first pinion cable 76 which is attached to a take-up spool (not shown) which is connected to, and is capable of rotating, a first pinion 78. First pinion 78 is mounted onto second member 12, preferably near its anterior end. To reduce abrasion of first pinion cable 76, a tube 80 is preferably provided which is attached to
30 second member 12 and through which first pinion cable 76 is able to move.



Mounted onto third member 14 opposite first pinion 78 is first rack 82 which engages first pinion 78. Whenever it is desired to extend the device, handle element 54 is pushed anteriorly, thereby forcing second element 12 anteriorly. Since one end of first pinion cable 76 is fixed to 5 first member 10, the anterior motion of second member 12 causes first pinion 78 to rotate clockwise. Since the gears of first pinion 78 are engaged with first rack 82, the rotation of first pinion 78 brings about the anterior displacement of third element 14.

To effect the retraction of the device, second member 12 is equipped 10 with a second pinion 84, preferably at its posterior end, which engages second rack 86 mounted onto the interior surface of first member 10. A second pinion cable 88 is attached to second pinion 84 so as to be able to rotate it, and is attached at its other end to third member 14.

Whenever it is desired to retract the device, handle element 54 is 15 pushed posteriorly, thereby forcing second element 12 posteriorly. The posterior motion of second member 12 causes second pinion 84 to rotate as it steps down along second rack 86. This rotation serves to take up second pinion cable 88 and thereby to displace third member 14 posteriorly.

20 Preferably, a device according to this embodiment further includes means for preventing the rotation of third member 14 relative to second member 12. This means may take the form of a pin 90 which is attached to third member 14 and which is capable of sliding only along anti-rotation slot 92. Second member 12 is prevented from rotating relative to first 25 member 10 in similar fashion through the constraint offered by longitudinal slot 50 to the movement of rigid connector 52. Eliminating the rotation of the members relative to one another ensures that the rack-and-pinions are properly engaged at all times.

To help centralize third member 14, second member 12 is preferably 30 equipped with a centralizing wheel 94 which tends to keep third member



14 centralized and ensures proper engagement of first pinion 78 with first rack 82.

In each of the described embodiments it may be desirable to add one or more springs (not shown) which will tend to facilitate and expedite the extension (or the retraction) of the outlying members. When retracting (or extending) such a device, sufficient additional force would have to be applied to overcome the opposing force of the springs.

An embodiment which resembles that shown in Figure 5 is shown in Figure 6, the major difference between the two being the presence of a suitable motor 100 which serves to rotate a gear wheel 102 in either sense. Gear wheel 102 engages a notched bar 104 attached to second member 12 so that rotation of gear wheel 102 is effective in raising or lowering second member 12.

Figure 7 shows an embodiment similar to that shown in Figure 1 but including a motor 100 as in Figure 6 which serves to rotate a pair of wheels 106 and 108 in either sense. The rotation of wheels 106 and 108 serves to simultaneously take in and let out first flexible connectors 16 so as to move second member 12 in the way described above with respect to Figure 1. Also shown in Figure 7 is a modification which includes a catch bag 110 which allows the device, with a proper tongs 44 or scissors-type attachment, to be used in the picking and gathering of fruits from a tree.

Shown in Figure 8 is another embodiment according to the present invention. The embodiment includes a first member 200, a second member 202 and a third member 204. The operating principle is similar to that in the embodiments described above but the means for implementing the principle differ somewhat, as described below. In this and subsequently described configurations the flexible members, if any, are all internal to the device which prevents the flexible members, when present, from getting dirty or worn.

30 First member 200 and third member 204 are each slidable within

second member 202. Mounted in second member 202 is a continuous band 206 which is attached to both first member 200 and to third member 204. When first member 200 is pulled downward, continuous band 206 is forced to rotate clockwise, thereby pulling third member 204 upwards, and vice versa.

Also shown in Figure 8 is a modification whereby first member 200 is made up of two detachable sections -- an anchoring section 210 which is attached to continuous band 206, and a replaceable section 212 which can be screwed into, or otherwise detachably connected to, anchoring section 210. A similar arrangement is shown for third member 204 which is made up of anchoring section 214 and replaceable section 216. This arrangement makes it possible to readily lengthen or shorten the two members and/or replace them with members having particularly suitable properties, as desired, for a particular application.

Figure 9 shows an embodiment which is similar to that of Figure 8 but wherein the continuous band is replaced by a toothed wheel 220 which engages toothed bars 222 and 224 connected to first member 200 and to third member 204, respectively. Stops 226 and 228 ensure that neither of the moveable members is able to be pulled completely out from second member 202. Figure 9 also shows the possibility of using sensors 230 and 232 detect the position of the moving parts of the device and could be used in a variety of ways. For example, in applications where it is desired to periodically extend and retract third member 204 to produce a series of strokes, as in painting, the sensor could be used to detect the end of a stroke and to actuate a motor to change the direction of third member 204.

A variation of the embodiment of Figure 9 is shown in Figure 10. In this embodiment two toothed wheels 240 and 242 are connected by continuous band 244 which makes it possible to extend third member 204 approximately twice as far as is possible with the embodiment of Figure 9.



Yet another configuration is illustrated in Figures 11 and 12 which somewhat resembles the embodiment of Figure 10. In this embodiment the movement of first member 200 downward causes toothed wheel 240 to rotate counterclockwise. Since toothed wheels 240 and 242 are connected, 5 the rotation of wheel 240 brings about the counterclockwise rotation of wheel 242 whose teeth interact with third member 204 causing it to extend out of second member 202.

Figure 12 shows a close-up view of one section of the device of Figure 11 wherein third member 204 is hollow so as to be able to 10 accommodate the flow of fluids, such as water, through the device. The device further includes a flexible, bellows-like hollow tube 250 which flexibly connects third member 204 with the inlet 252 through which fluid is introduced to the system. In this way, inlet 252 can be fixed to first member 200 yet third member 204 can be caused to extend away from 15 second member 202 without losing hydraulic communication with inlet 252. Such a configuration is useful, for example, for use with vacuum cleaners and spray painting devices.

As mentioned above, a device according to the present invention may be used with any one of a large variety of tools connected to one or 20 both of its ends. Some examples of such tools are shown in Figure 13.

Shown in Figures 14 and 15 are views of a device according to the present invention as it might appear in applications involving the painting of a wall (Figures 14A and 14B) and sweeping a floor (Figures 15A and 15B).

25 Shown in Figure 16 are four devices according to the present invention which have been interlinked so that the extension of one unit causes the extension of the others. Illustrated in Figure 16 are four units which are rigidly connected to each other. Each pair of adjoining units are further connected in that the outward motion of the third member of one 30 device brings about the extension of the adjoining device. One way of



accomplishing this is illustrated with regard to the pair of devices at the left and top of Figure 16.

Another application, which is based on the configuration of Figure 16 is illustrated in Figure 17A and 17B where a set of devices according to the present invention are shown assembled into a rapidly assembled and highly versatile structure which can serve, for example, the underlying structure for a tent, and the like. Preferably, such a device would also include an appropriate tarpaulin or other suitable cloth to close off the open spaces between the rigid structure. The spaces could also be closed by sliding panels along the lines of the embodiment of Figure 4.

Another application of devices according to the present invention is illustrated in Figures 17A, 17B 18A and 18B, which depict various versions of a tripod incorporating devices according to the present invention in the tripod legs. In each case, the device includes a central pole and three legs. For clarity, one of the three legs is omitted in each drawing.

The configurations of Figures 18A and 18B show the closed and open positions of an embodiment which operates along the lines of the embodiment of Figure 1 such that an upward motion leads to the extension of the legs. In Figures 19A and 19B are shown the closed and open positions of a configuration along the lines of Figures 3 and 5 wherein a downward motion is used to extend the legs. In both configurations, it is possible to adjust the length of each leg individually before the leg is locked in position.

Finally, shown in Figures 20A, 20B and 20C are three applications of devices according to the present invention in the context of electric shockers, such as those which might be used to ward off an attack. Figure 20A shows a walking cane equipped with a shocker which can be placed where desired by use of a release lever and a system of springs. Shown in Figure 20B is an umbrella which operates in the same way. Finally,



Figure 20C features a stick which, in addition, may feature a knife or similar cutting tool to cut through the attacker's clothes so as to allow better contact of the shocker with the attacker's skin.

While the invention has been described with respect to several 5 embodiments, it will be appreciated that many variations, modifications and other applications of the invention may be made.

WHAT IS CLAIMED IS:

1. An extendible-retractable device, comprising:
 - (a) a first member;
 - (b) a second member movable relative to said first member;
 - (c) a first flexible connector attached to a posterior portion of said second member, said first flexible connector being constrained by and being movable relative to a first location of said first member; and
 - (d) a second flexible connector attached to a posterior portion of said second member, said second flexible connector being constrained by and being movable relative to a second location of said first member, said second location being posterior of said first location, said first flexible connector and said second flexible connector being coupled to each other so that said first flexible connector, said second flexible connector and said second member all move simultaneously.

2. A device as in claim 1, further comprising:
 - (e) a third member movable relative to said first member and said second member;
 - (f) a third flexible connector attached to a posterior portion of said third member, said third flexible connector being constrained by and being movable relative to a first location of said second member, said third flexible connector being attached to a first attachment location of said first member so that anteriorly-directed motion of said second member results in anteriorly-directed motion of said third member; and
 - (g) a fourth flexible connector attached to a posterior portion of said third member, said fourth flexible connector being constrained by and being movable relative to a second



location of said second member, said second location being posterior of said first location, said fourth flexible connector being attached to a second attachment location of said first member so that posteriorly-directed motion of said second member results in posteriorly-directed motion of said third member.

3. A device as in claim 2 wherein said first member, said second member and said third member are nested so that said third member is within said second member and said second member is within said first member.

4. A device as in claim 3 wherein said first member, said second member and said third member are approximately cylindrical.

5. A device as in claim 2 wherein said first member, said second member and said third member are arranged next to each other.

6. A device as in claim 3 wherein said first attachment location and said second attachment location are on opposite sides of said first member.

7. A device as in claim 2 wherein said flexible connectors are cables.

8. A device as in claim 2 wherein said first location of said first member is the anterior edge of said first member and said second location of said first member is the posterior edge of said first member.

9. A device as in claim 2 wherein said first location of said first member is a first hole in said first member and said second location of said first member is a second hole, posterior of said first hole, through said first



member.

10. A device as in claim 2 wherein said coupling of said first flexible connector and said second flexible connector being to each other is achieved through a movable handle.

11. A device as in claim 10 wherein said movable handle can be immobilized through detachable attachment to said first member.

12. A device as in claim 2 wherein said coupling of said first flexible connector and said second flexible connector being to each other is achieved through a winch mechanism attached to said first member.

13. A device as in claim 2, further comprising:

(h) a tool attached to at least one of said members.

14. A device as in claim 13 wherein said tool is a paint brush, a paint roller, a mop, a dust brush, a cutting tool, a tongs, or a fitting capable of attaching the device to another body.

15. A device as in claim 13 wherein said tool is capable of being activated remotely by the user.

16. An extendible-retractable device, comprising:

(a) a first member formed with a longitudinal slot;

(b) a second member movable relative to said first member;

(c) a rigid connector attached to a posterior portion of said second member, said rigid connector being slidable through said longitudinal slot of said first member so that said second member is moved whenever said rigid connector is moved;



- (d) a third member movable relative to said first member and said second member;
 - (e) a third flexible connector attached to a posterior portion of said third member, said third flexible connector being constrained by and being movable relative to a first location of said second member, said third flexible connector being attached to a first attachment location of said first member so that anteriorly-directed motion of said second member results in anteriorly-directed motion of said third member; and
 - (f) a fourth flexible connector attached to a posterior portion of said third member, said fourth flexible connector being constrained by and being movable relative to a second location of said second member, said second location being posterior of said first location, said fourth flexible connector being attached to a second attachment location of said first member so that posteriorly-directed motion of said second member results in posteriorly-directed motion of said third member.
17. An extendible-retractable device, comprising:
- (a) a first member formed with a longitudinal slot and having a second rack;
 - (b) a second member movable relative to said first member and having a first pinion near its anterior end and a second pinion near its posterior end, said second pinion engaged to said second rack;
 - (c) a rigid connector attached to a posterior portion of said second member, said rigid connector being slidable through said longitudinal slot of said first member so that said second member is moved whenever said rigid connector is moved;

- (d) a third member movable relative to said first member and said second member, said third member having a first rack engaged to said first pinion, said pinion being rotatable by a cable which is attached to said first member so that anteriorly-directed motion of said second member results in anteriorly-directed motion of said third member, said third member being attached to a second pinion cable for rotating said second pinion, so that posteriorly-directed motion of said second member results in posteriorly-directed motion of said third member.
18. An extendible-retractable device, comprising:
- (a) a first member;
 - (b) a second member, said first member being movable relative to said second member;
 - (c) a third member, said third member being movable relative to said second member;
 - (d) a flexible connector mounted in said second member, said flexible connector being connected to said first member and to said second member such that said first and third members move together in opposite directions.
19. A device as in claim 18, wherein at least one of said first and third members is formed of at least two portions, one of said portions being permanently attached to said flexible connector and at least one of said portions being detachable.
20. An extendible-retractable device, comprising:
- (a) a first member having a first rack;
 - (b) a second member, said first member being movable relative



to said second member;

- (c) a third member, said third member being movable relative to said second member and having a second rack;
- (d) a toothed wheel mounted onto said second member, said toothed wheel engaging said first and said second racks such that said first and third members move together in opposite directions.

21. A device as in claim 20, further comprising sensor means for sensing the position of at least one of said first and third members relative to said second member.

22. An extendible-retractable device, comprising:

- (a) a first member having a first rack;
- (b) a second member, said first member being movable relative to said second member;
- (c) a third member, said third member being movable relative to said second member and having a second rack;
- (d) a pair of toothed wheels mounted onto said second member, said toothed wheels being connected to each through a flexible connector, said toothed wheels engaging said first and said second racks such that said first and third members move together in opposite directions.



MARK M. FRIEDMAN
MOSDECHAI

Patent 3,710,000

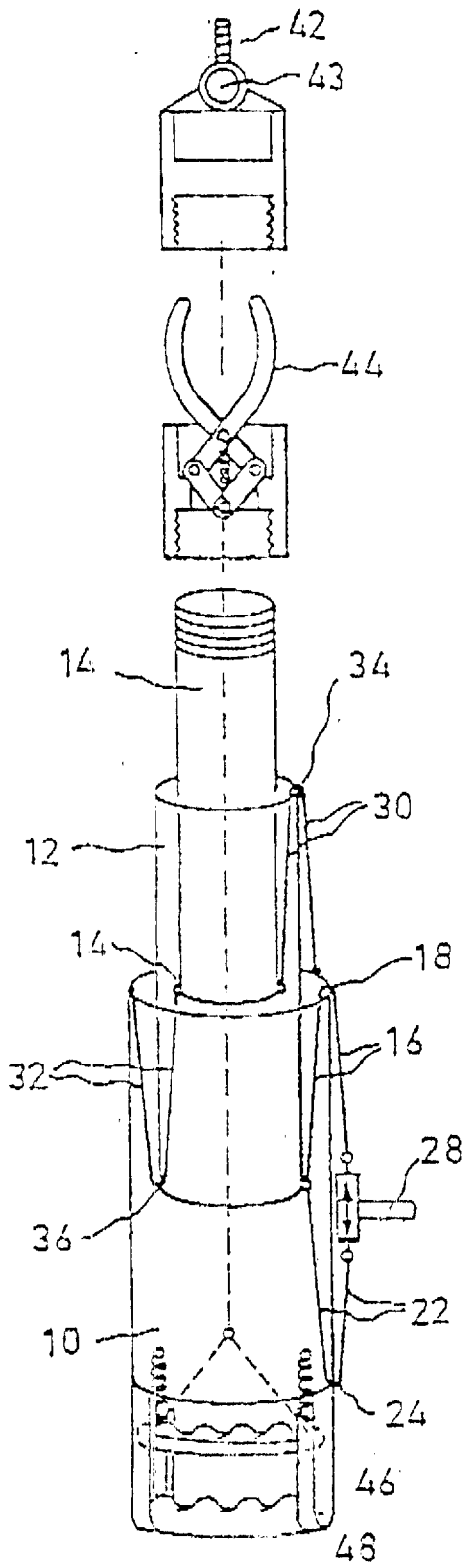

FIG. 1

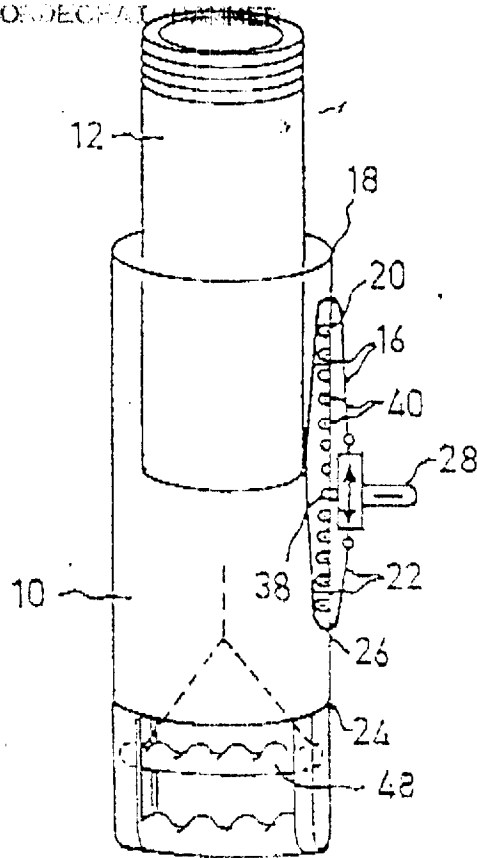

FIG. 2

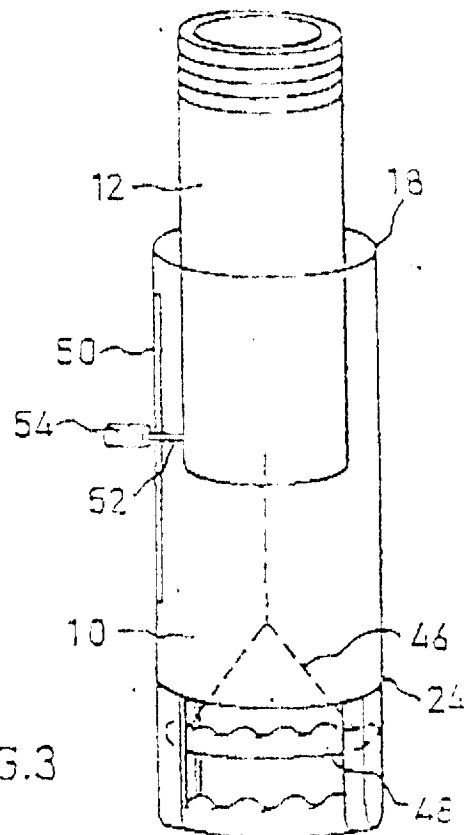

FIG. 3

BAD ORIGINAL



MORDECHAI HAMMER

10000

FIG. 4

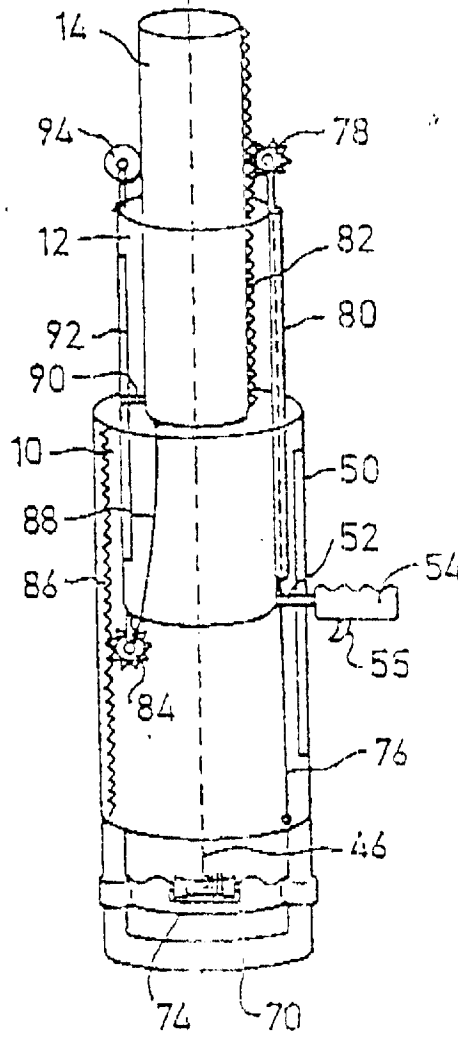
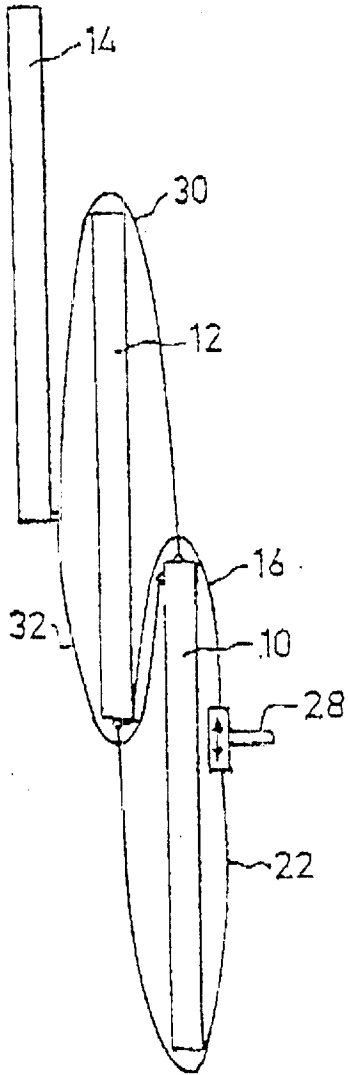

FIG 5

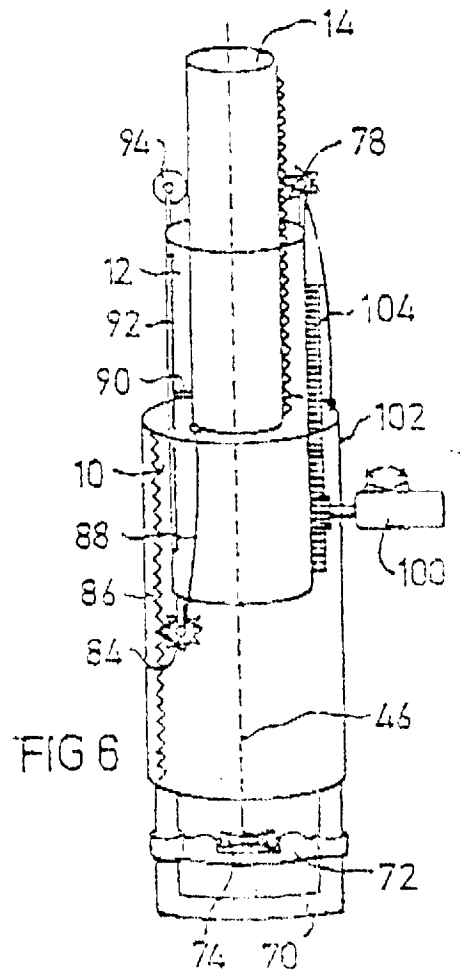

FIG 6

BAD ORIGINAL



MORDECHAI HAMMER

10000

FIG 7

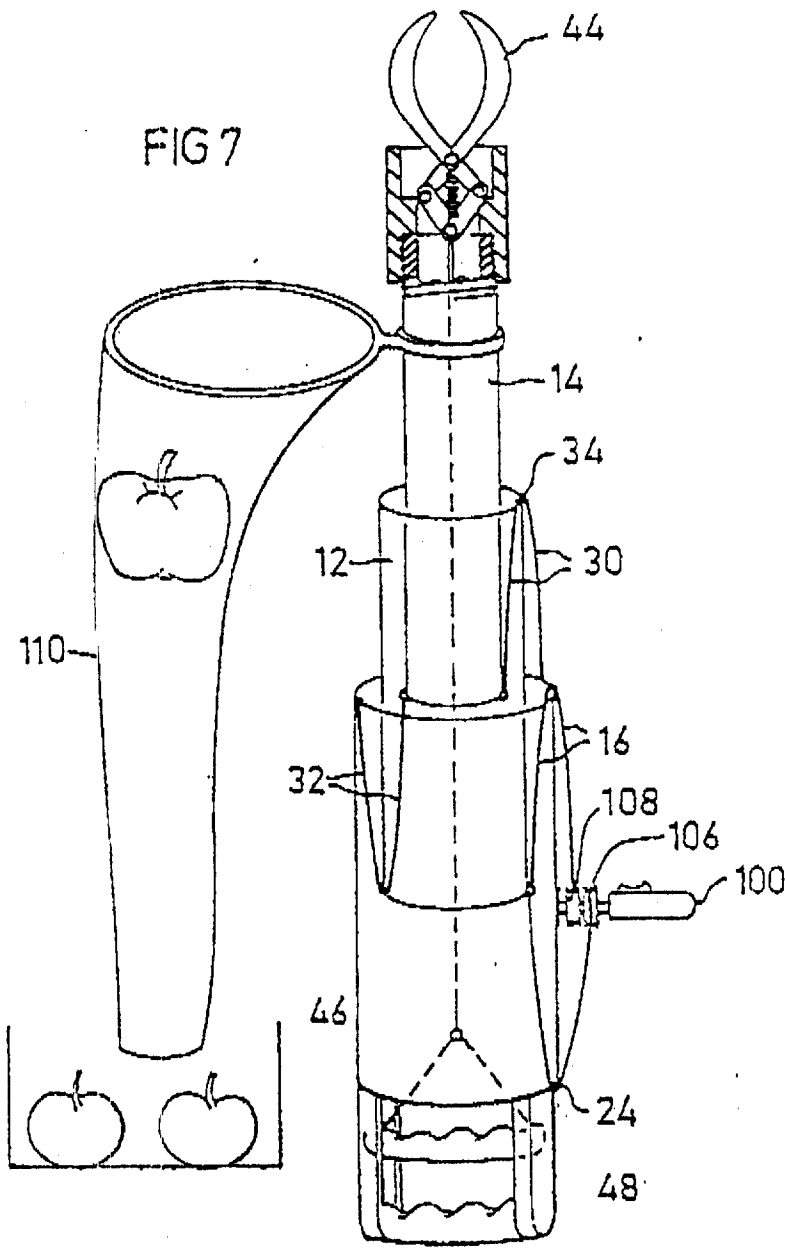

FIG 8

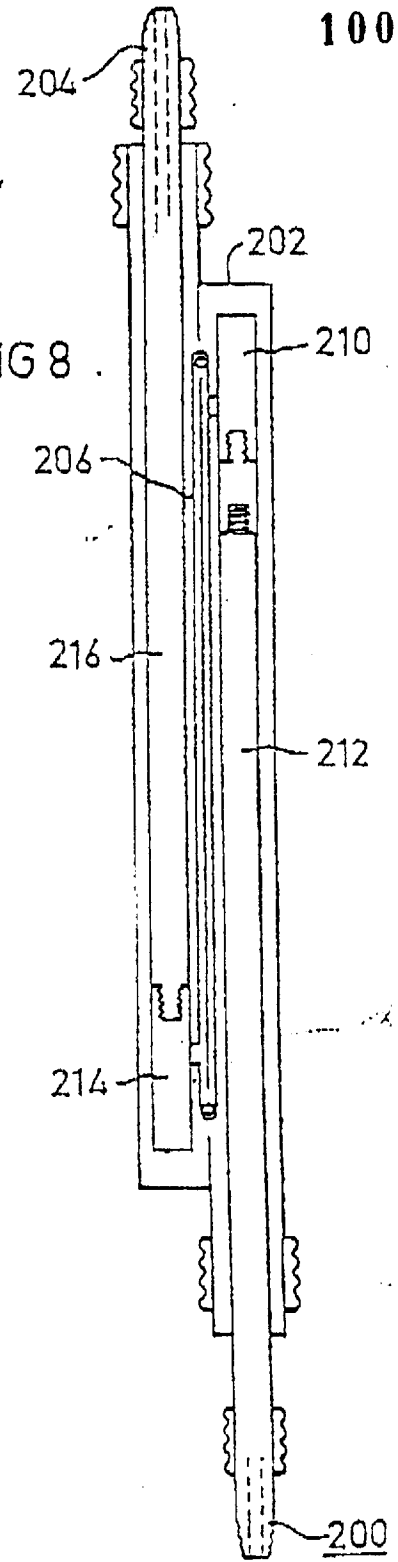
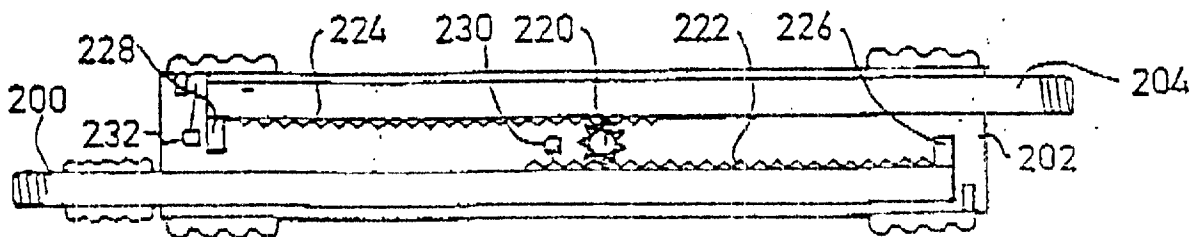

FIG 9



MORDECHAI HAMMER

FIG 10

10000

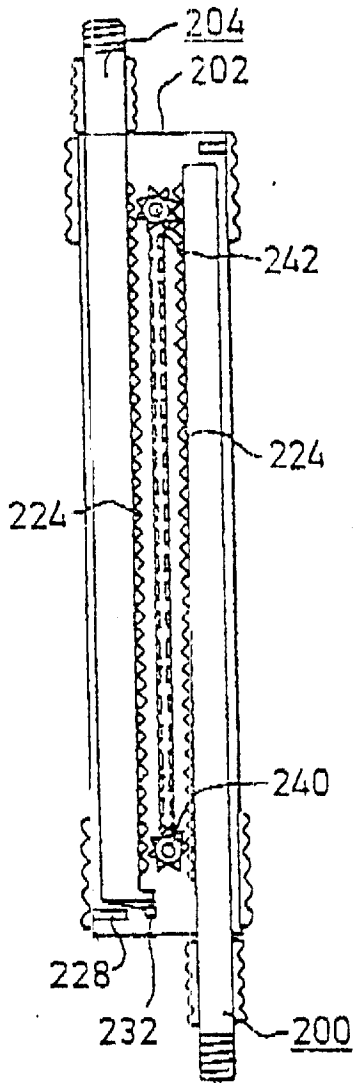

FIG 11

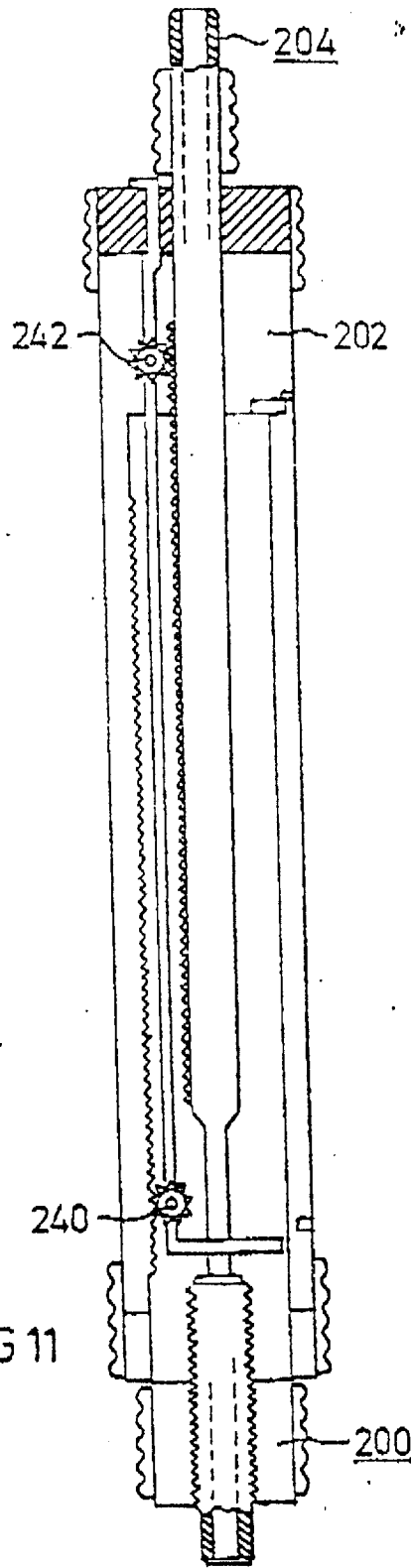
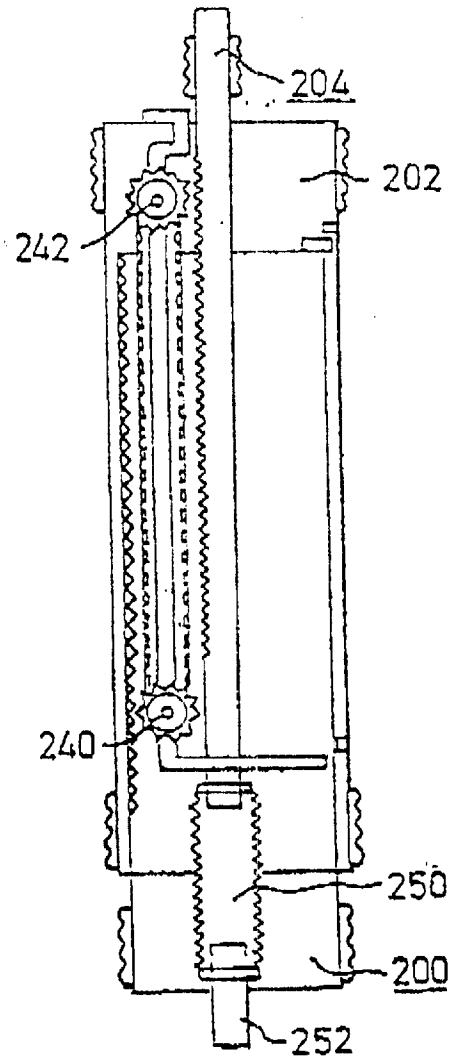

FIG 12



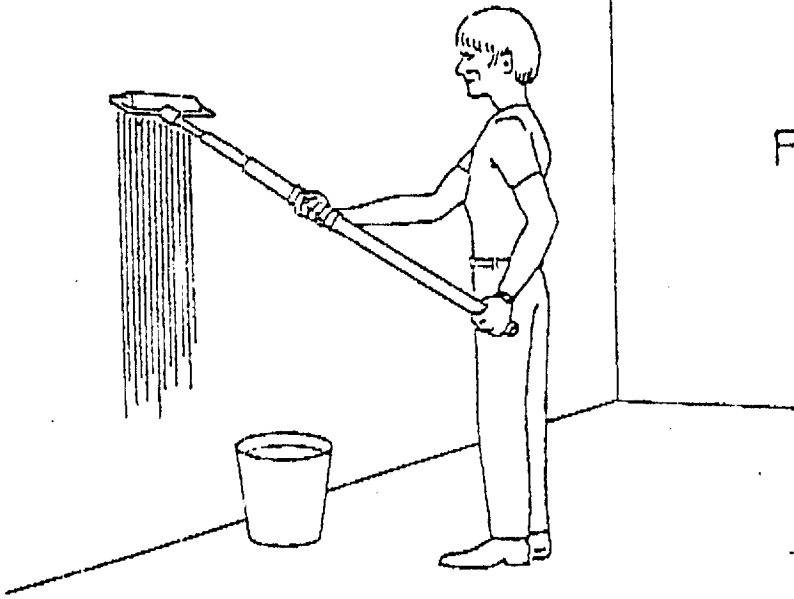

FIG 14a

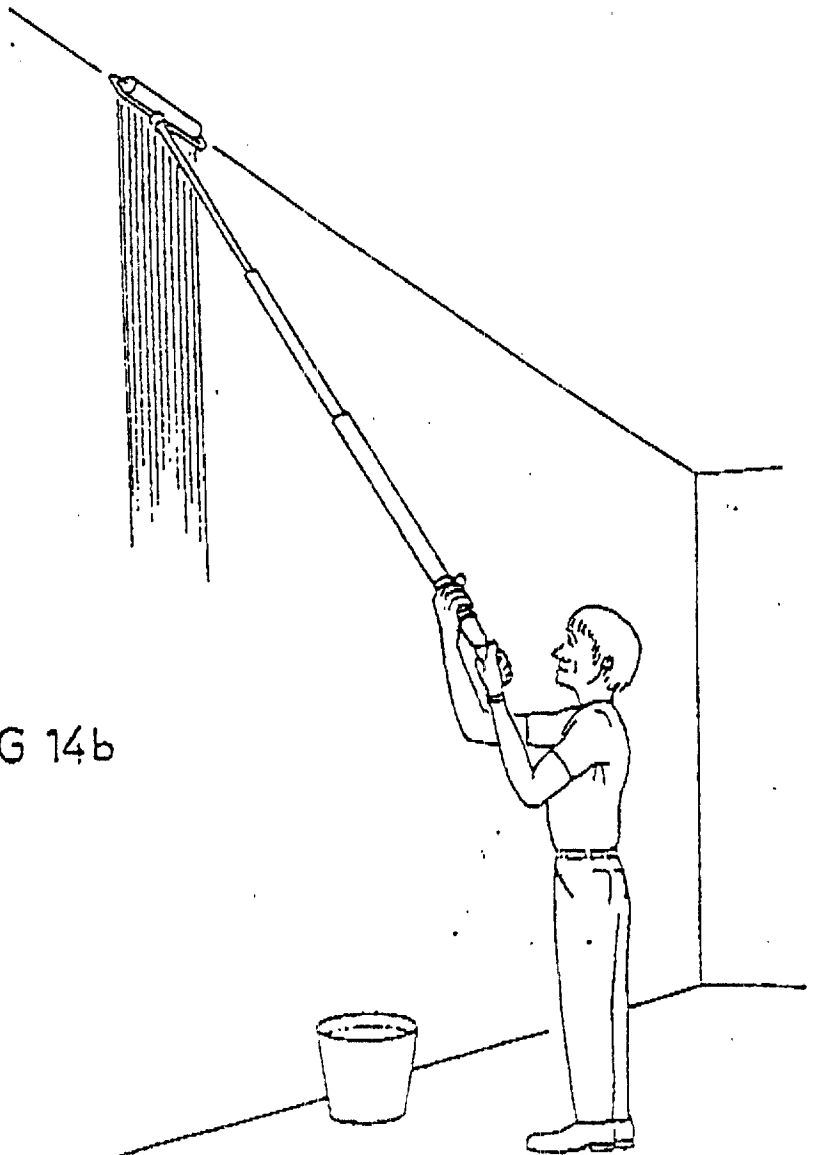

FIG 14b



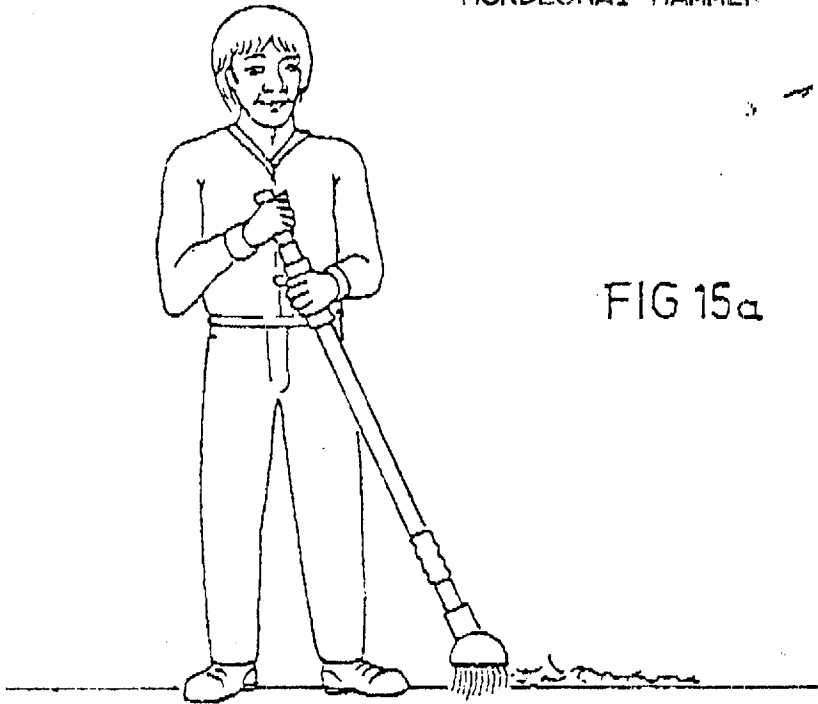

FIG 15a

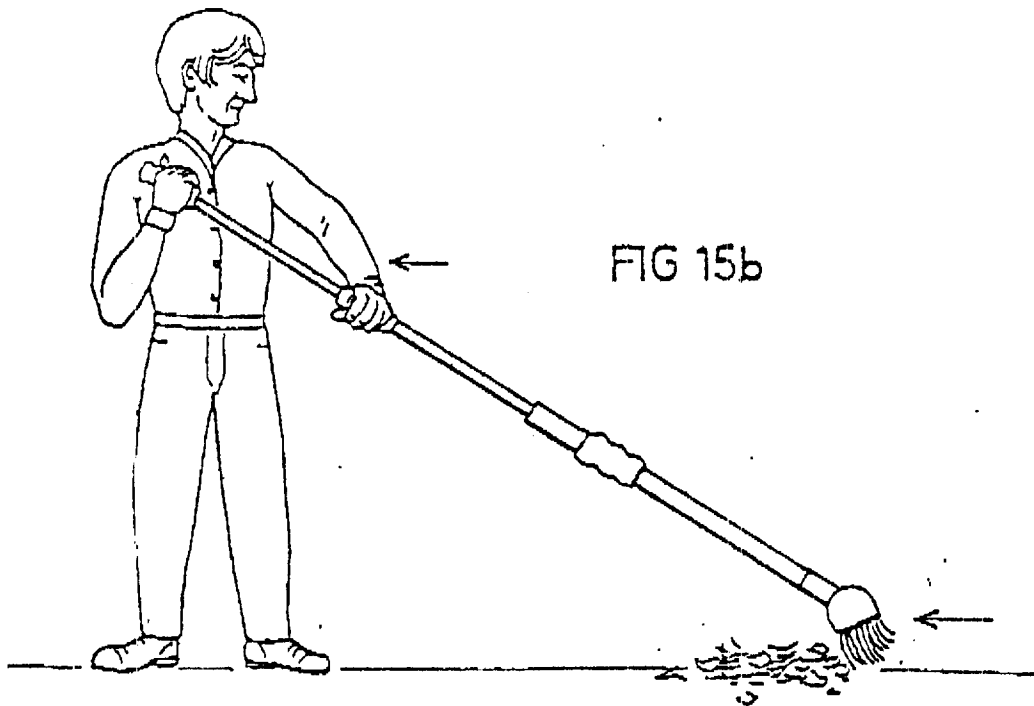

FIG 15b



Br. n° MARK M. FRIEDMAN planche 0/10
MORDECHAI HAMMER
10000

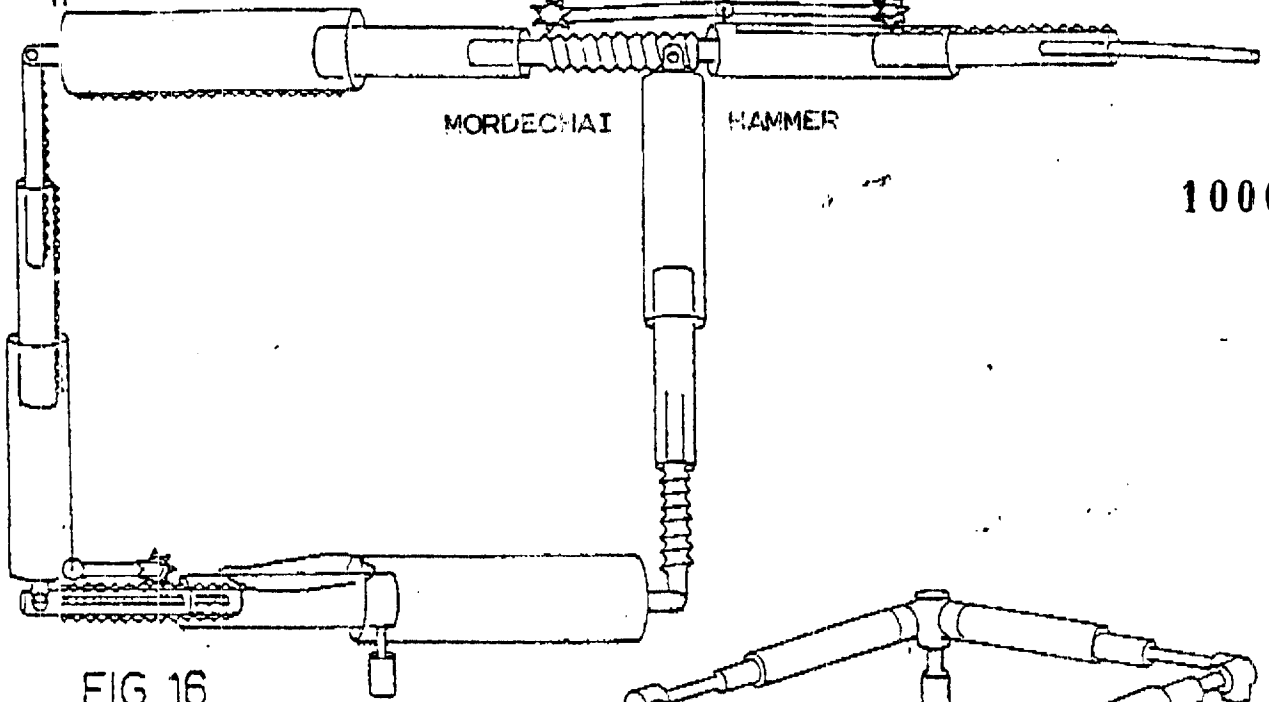

FIG 16

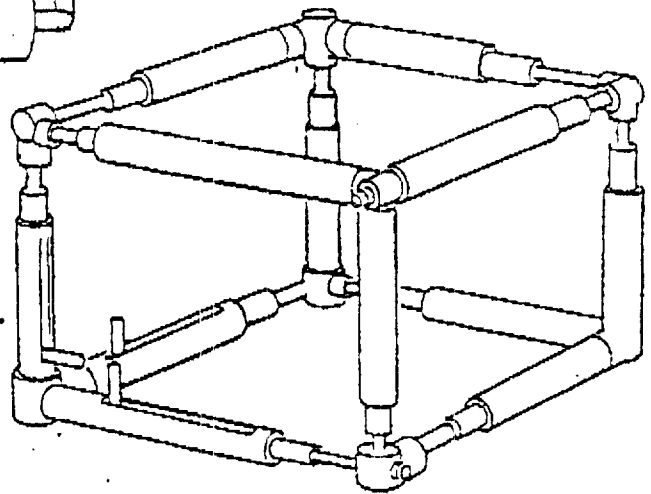

FIG 17a

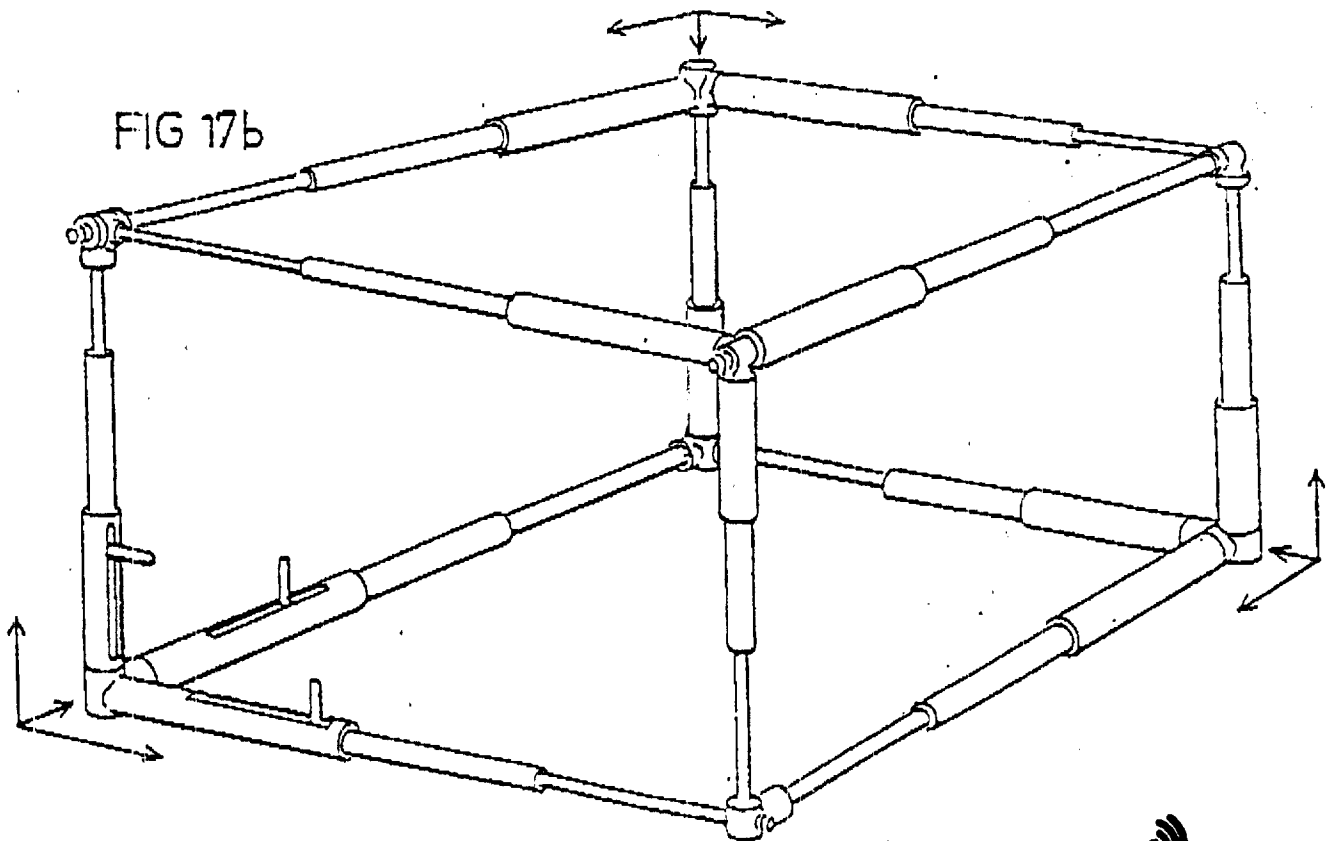
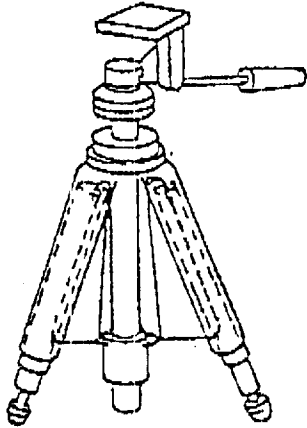

FIG 17b

BAD ORIGINAL



FIG 18a



10000

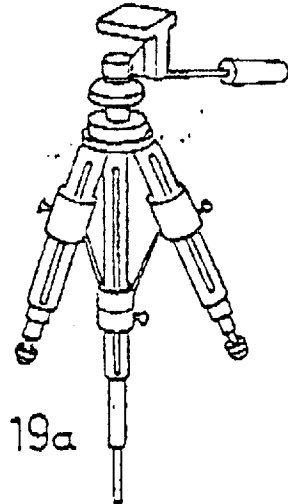

FIG 19a

FIG 18b

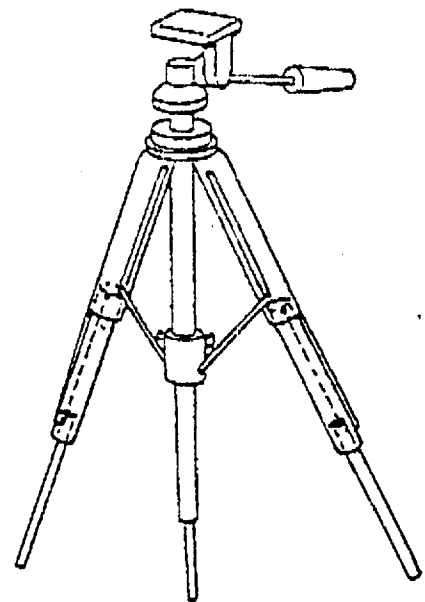
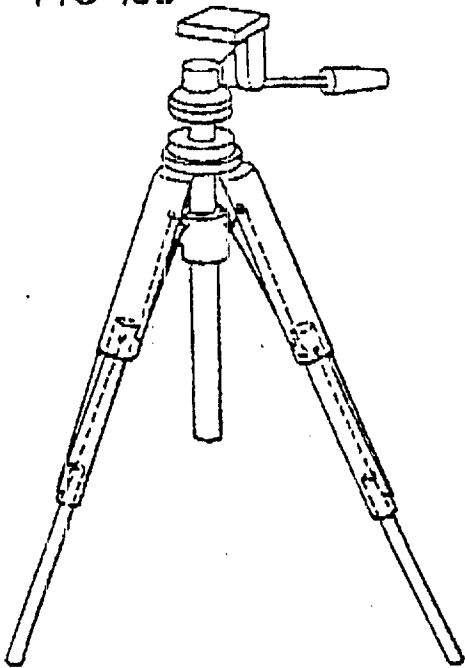

FIG 19b



FIG 20a

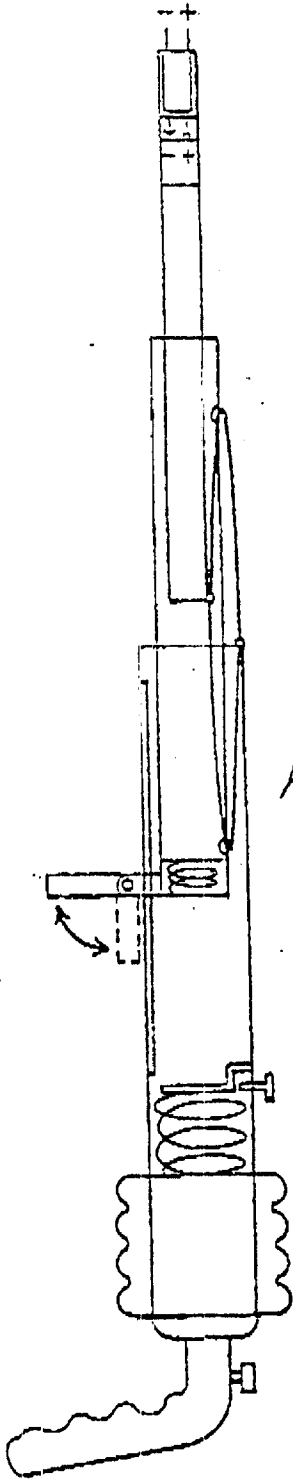

FIG 20b

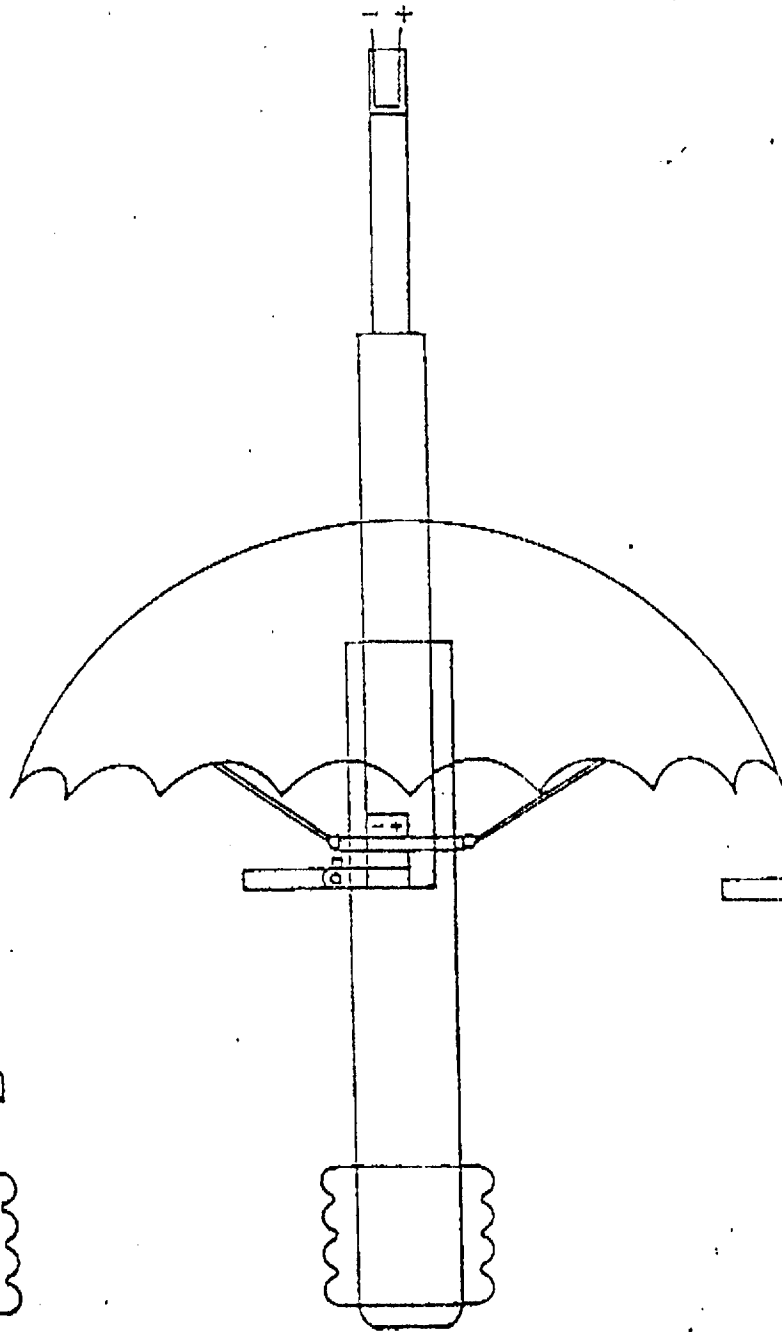

FIG 20c

