

*J. Briggs,*  
*Reeling Mach.*

*No. 108,080.*

*Patented Oct. 25. 1870.*

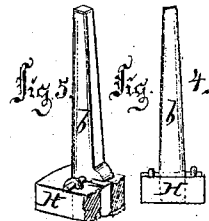
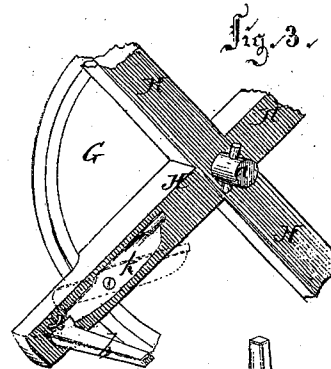
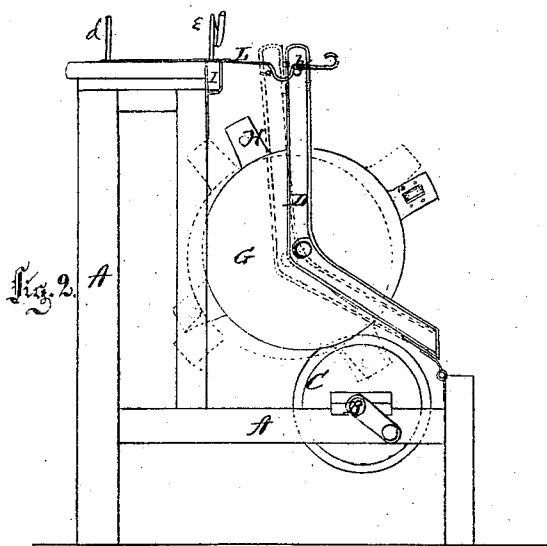
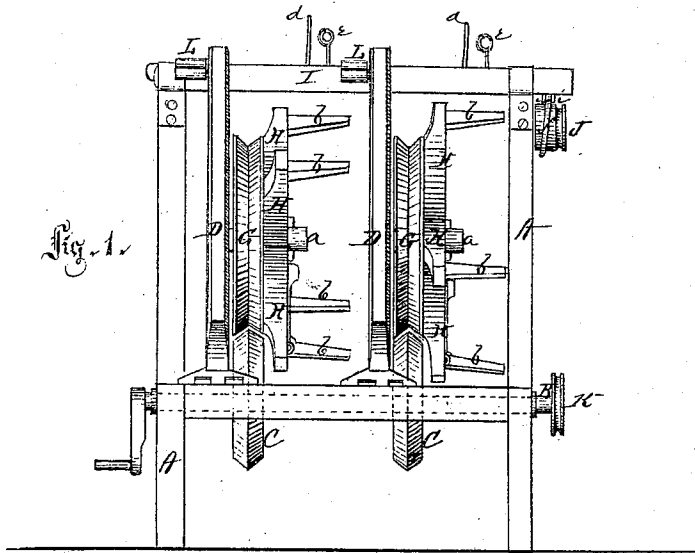

*Witnesses:*  
*C. A. Covert,*  
*J. E. Hutchinson*

*Inventor:*  
*John Briggs*  
*Alexander Mason*  
*Atty.*

# United States Patent Office.

JOHN BRIGGS, OF HIGGANUM, CONNECTICUT.

Letters Patent No. 108,680, dated October 25, 1870.

## IMPROVEMENT IN REELING-MACHINES.

The Schedule referred to in these Letters Patent and making part of the same.

### To all whom it may concern:

Be it known that I, JOHN BRIGGS, of Higganum, in the county of Middlesex and in the State of Connecticut, have invented certain new and useful Improvements in Yarn-Reels; and do hereby declare that the following is a full, clear, and exact description thereof, reference being had to the accompanying drawing and to the letters of reference marked thereon, making a part of this specification.

The nature of my invention consists in the construction and arrangement of a "yarn-reel," as will be hereinafter fully set forth.

In order to enable others skilled in the art to which my invention appertains to make and use the same, I will now proceed to describe its construction and operation, referring to the annexed drawing, in which—

Figure 1 is a front view, and

Figure 2 a side view of my entire machine.

Figure 3 is an enlarged section of one of the reels, showing the jointed or hinged pin in the same.

Figures 4 and 5 are also views of said jointed or hinged pin.

A represents the frame-work of my machine, the rear part of which is made considerably higher than the front part, as shown in fig. 2.

In suitable journal-boxes on the front part of the frame is placed a horizontal shaft, B, which is provided with any desired number of wheels, C C, placed at suitable distances apart. The outside circumference of these wheels is beveled from the center inward toward the sides, making the edge V-shaped, as shown in fig. 1.

Upon the front edge of the frame A are hinged bent arms, D D, which are constructed as shown in fig. 2, and correspond in number and position with the wheels C C.

In the bend or angle of each arm D is a wrist-pin, *a*, upon which is placed a reel, consisting of a wheel, G, and cross-arms H H, secured to the wheel, and a pin, *b*, in the outer end of each arm H.

The circumference of the wheels G is grooved, to correspond with the beveled edge of the wheel C, so that each wheel G fits over the edge of one of the wheels C, and will revolve by friction when the shaft B is put in motion.

On the rear part of the frame are pins, *d*, upon

which the bobbins are placed, the yarn passing from said bobbins, through guide-wires *e e*, to the reels.

The guide-wires *e* are placed upon a bar, I, which slides back and forth, so as to distribute the yarn evenly over the arms *b b* of the reels.

The bar I is made to move back and forth by the following means:

On the end of the main shaft B is a pulley, K, connected by a belt with a pulley, J, attached on the side of the frame A, as shown in fig. 1.

On this pulley is an eccentric or diagonal flange, *f*, which fits between pins, *i i*, on the under side of the bar I, which is thus moved endwise back and forth.

When the machine is in operation the reels are held against the wheels C C by their own weight, as the centers of said reels are in rear of the main shaft B, and the reels bear on the wheels C C, not on top, but more toward the rear, and the motion of the reel has a tendency to throw them further down, and, consequently, closer to the wheel.

Any one of the reels may be thrown out of gear while mending threads, or for any other purpose, by throwing the arm D slightly forward and letting a pin, *h*, at its upper end, rest on a spring-bar, L, attached to the upper end of the frame A. The arms D can be thrown entirely over forward, and rest upon the front edge of the frame, to remove the skein.

One of the pins *b* in each reel is hinged in a mortise at the outer end of one of the arms H, so as to be folded inward, for the purpose of removing the skein. This pin is held in its proper position, at right angles with the arm, by means of a button, *k*, as shown in fig. 3.

Having thus fully described my invention;

What I claim as new, and desire to secure by Letters Patent, is—

The combination of the shaft B, wheels or pulleys C C, hinged arms D D, reels G H, provided each with one pivoted pin, *b*, guide-bar I, spring bars L L, and pins *h h*, all constructed and arranged substantially as and for the purposes herein set forth.

In testimony that I claim the foregoing, I have hereunto set my hand this 6th day of July, 1870.

JOHN BRIGGS.

Witnesses:

STEPHEN N. GLADWIN,  
ABRAHAM BRAINARD.