

(No Model.)

3 Sheets—Sheet 1.

F. N. ETHRIDGE.
MAIL MARKING MACHINE.

No. 522,049.

Patented June 26, 1894.

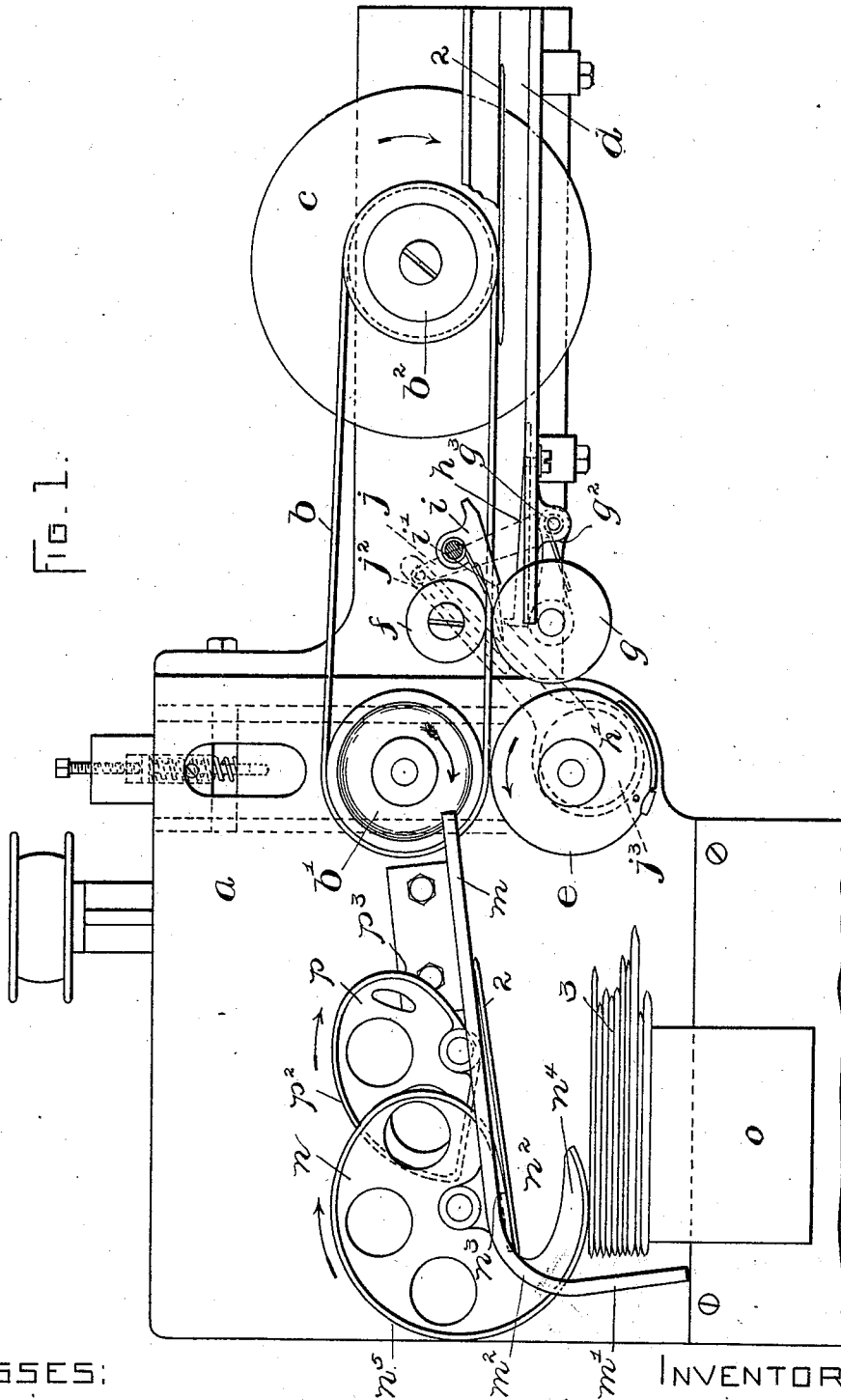

FIG. 1.

WITNESSES:
H. D. Harrison.
Samuel Davis.

INVENTOR:
F. N. Ethridge
Wright, Brown & Corrosby
attys.

F. N. ETHRIDGE.
MAIL MARKING MACHINE.

No. 522,049.

Patented June 26, 1894.

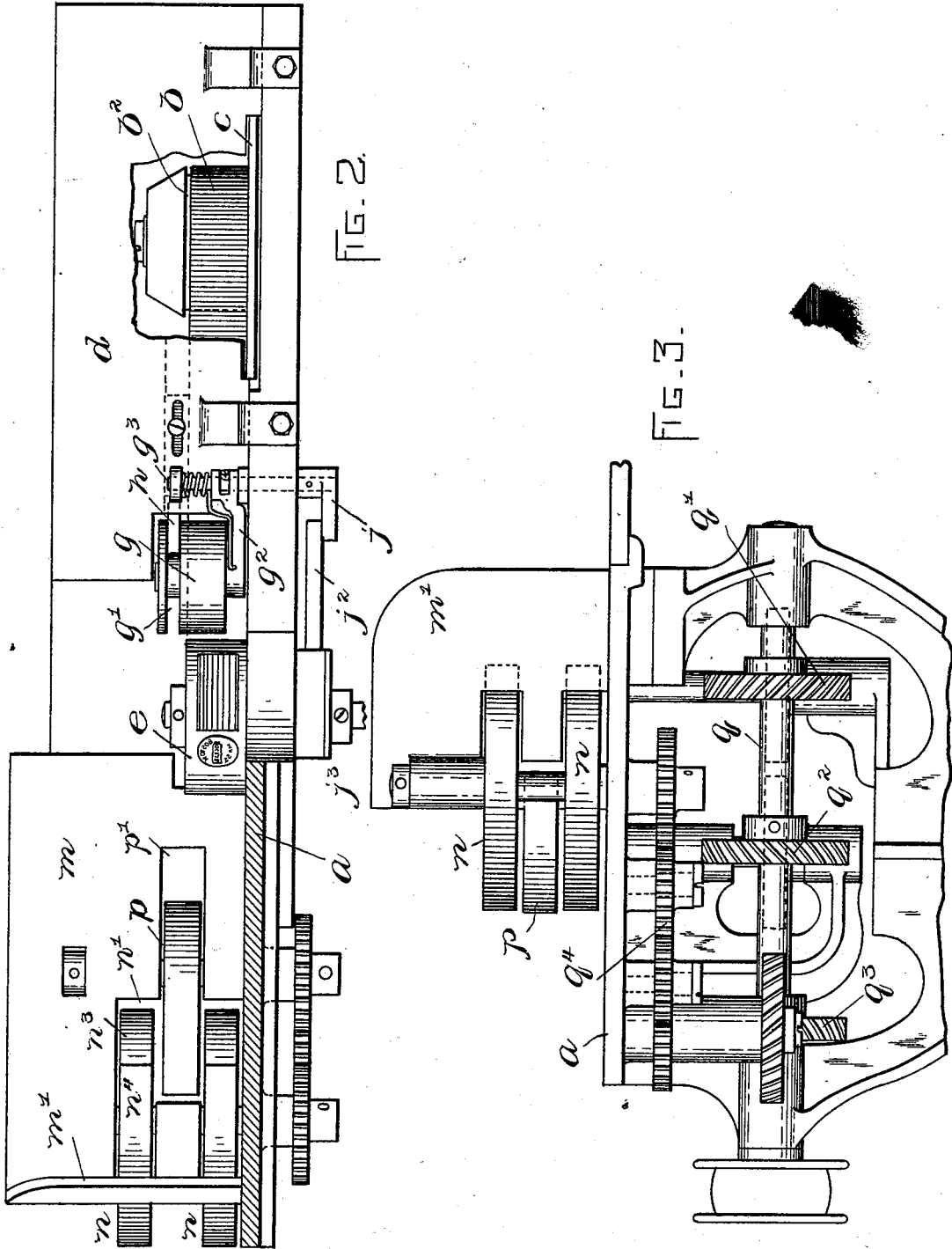

WITNESSES:
A. D. Harrison
Charles Davis

INVENTOR:
F. N. Ethridge
Wright, Brown & Crossley

F. N. ETHRIDGE.
MAIL MARKING MACHINE.

No. 522,049.

Patented June 26, 1894.

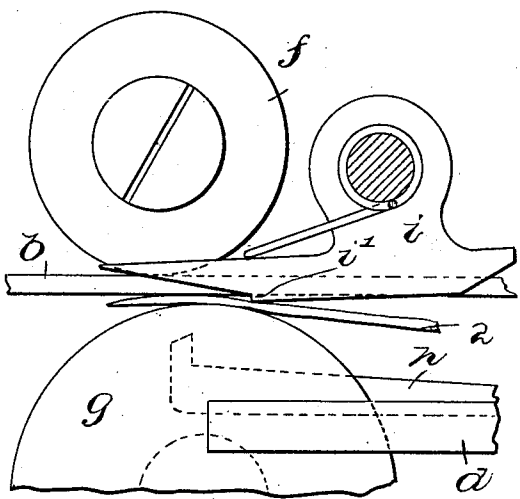
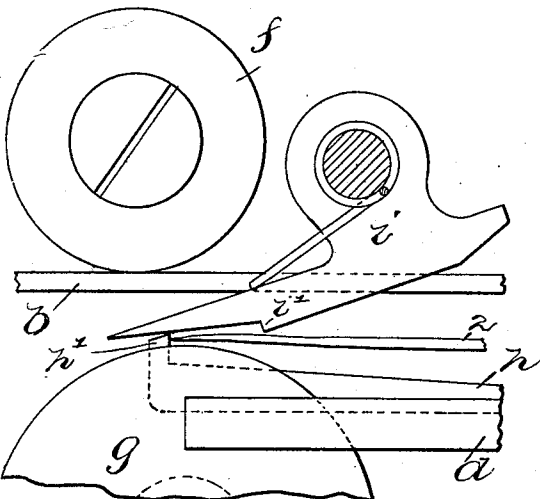
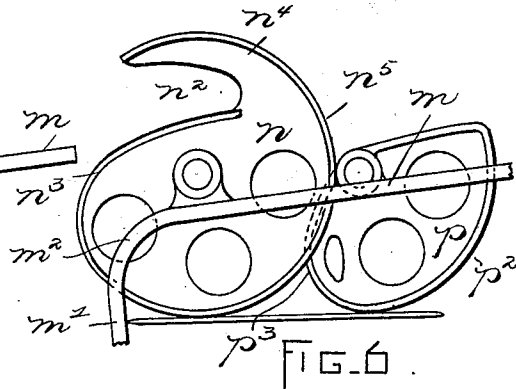
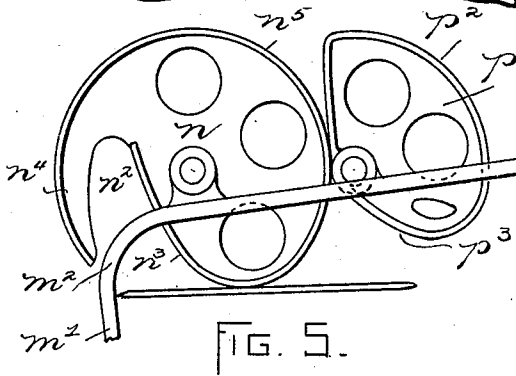
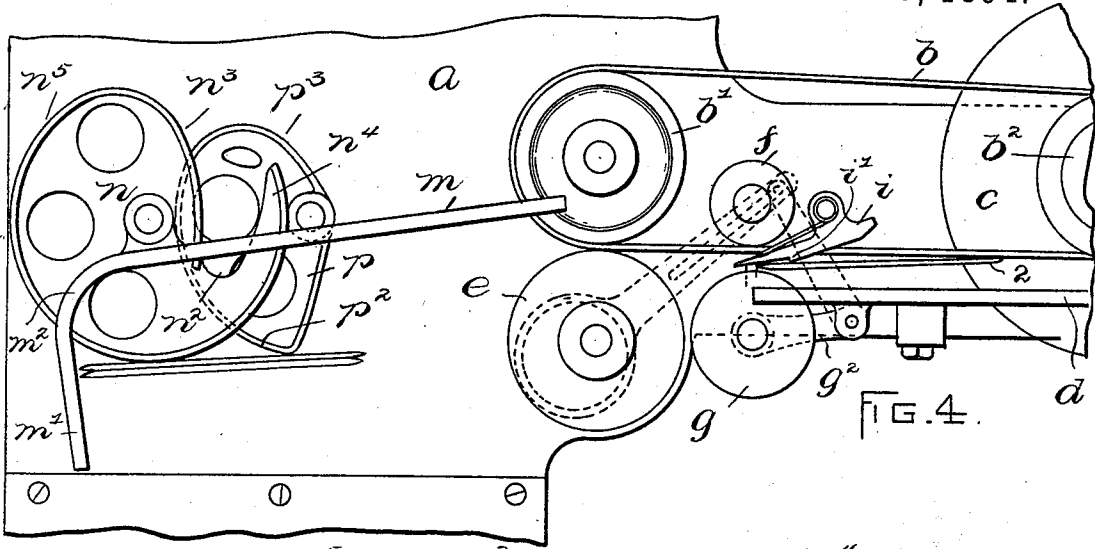

WITNESSES:
H. D. Harrison.
Charles Davis.

INVENTOR:
F. N. Ethridge.
 by *Wright, Brown & Corvessy*

UNITED STATES PATENT OFFICE.

FRANK N. ETHRIDGE, OF BOSTON, MASSACHUSETTS, ASSIGNOR TO ALBERT LEAVITT, OF SAME PLACE.

MAIL-MARKING MACHINE.

SPECIFICATION forming part of Letters Patent No. 522,049, dated June 26, 1894.

Application filed November 7, 1893. Serial No. 490,252. (No model.)

To all whom it may concern:

Be it known that I, FRANK N. ETHRIDGE, of Boston, in the county of Suffolk and State of Massachusetts, have invented certain new and useful Improvements in Mail-Marking Machines, of which the following is a specification.

The object of this invention is to simplify mail-marking machines and increase their efficiency.

To this end, the invention consists in an improved feeder, which takes the mail-pieces in the direction of travel of the acting stretch of the endless conveyer, and at the same time into contact with said stretch of the conveyer.

The invention further consists in an improved timing mechanism, which is so constructed as to prevent backward movement of the mail-pieces.

The invention further consists in a stacking device, in the form of a disk, having a throat which receives the mail-pieces and a cam-surface which stacks them, and an auxiliary stacking disk acting in conjunction therewith.

The accompanying drawings illustrate an embodiment of the invention.

Figure 1 shows a plan view of the machine, as it appears in operation. Fig. 2 shows a side elevation of the machine, viewed from the lower side of Fig. 1, broken away at one part and in section at another part. Fig. 3 shows an end elevation, as viewed from the right of Fig. 1. Fig. 4 shows a partial plan of the machine, illustrative of a step in its operation. Figs. 5 and 6 show different positions of the stacking devices. Figs. 7 and 8 show details of the timing mechanism.

The same letters and numerals of reference indicate the same parts in all the figures.

In the drawings: The letter *a* designates the stationary horizontal bed of the machine, above which travels the endless belt or conveyer *b*, common to this class of machines, and running on pulleys *b'* *b*². Difficulty has been experienced with the conveyers now in use, from the fact that the mail-pieces are not always taken thereby in the proper position, with their edges horizontal, but the mail-pieces will sometimes tilt on the conveyer, by

reason of not being accurately fed thereto, and in such event do not pass to the marking devices, but escape from the machine; or, if they do reach the marking devices, are marked thereby at the wrong place. I believe I have solved the problem, by the employment of a novel feeder, which consists of a circular horizontal table *c*, which is carried by the pulley *b*², and extends under the stretches of the belt *b* and also over the bottom of the hopper *d* in which the mail-matter is deposited.

The mail-pieces will fall upon the rotating table *c*, and their edges will evenly engage the same, there being no projections to cause tilting of a mail-piece; and, the direction of rotation of the table being the same as the direction of travel of the belt, the mail-pieces will be carried forward by the table, and at the same time will be taken against the belt, for the plane of the path of movement of the table being horizontal intersects that of the path of movement of the belt, which is vertical. Each mail-piece will thus be carried into flat engagement with the belt, so that the latter will receive it properly positioned and feed it properly to the marking devices.

The letter *e* designates the marking-cylinder, which is opposed to the pulley *b'* and rotates in the opposite direction.

Timing mechanism, whereby the marking of each mail-piece at the proper place is assured, is arranged as follows: Opposed to an idler *f* on the inner side of the acting stretch of the belt, is a roller *g*, having an annular groove *g'*, and supported by a spring-pressed arm *g*², capable of limited play on a pivot-pin, *g*³, which is journaled in the bed *a* and in a bearing on the outer side of the hopper *d*, the limited play thus allowed the roller being to compensate for variations in thickness of mail-pieces. An arm *h* is fastened to the outer side of the hopper and extends into the groove *g'* of the roller *g*, and is formed with a stop-projection *h'* for the mail-piece to encounter. A spring-pressed finger *i* is pivoted inside the acting stretch of the belt and extends over the belt and into the groove *g'* of the roller *g*, and is adapted to deflect the approaching mail-piece against the stop

h' . This finger is formed with a shoulder i' , at a point in advance of the stop h' and for a purpose which will be explained hereinafter. An arm j , affixed to the pivot-pin g^3 below the bed α , is connected with a pitman j^2 , which co-acts with an eccentric j^3 on the journal of the marking-cylinder.

The approaching mail-piece 2 (see Fig. 7) is deflected by the finger i against the stop h' , the roller g being at this time in its rearward position and said stop projecting beyond its periphery. The mail is held until the revolution of the marking-cylinder causes the eccentric to move the roller g toward the belt. When thus moved toward the belt, the roller acts against the mail-piece and pushes it off the stop h' , and moves said mail-piece against the finger i , which yields and allows the mail-piece to be carried against the belt. Thus each mail-piece is timed with respect to the marking-cylinder, so that it will receive the mark at the proper place.

When the mail-piece h is pushed against the finger i , it encounters the shoulder i' (see Fig. 8), and is prevented thereby from being pushed back by the roller g .

After the mail-pieces leave the marking devices, they are received and acted upon by stacking devices, which are constructed and arranged as follows: A guard m is erected on the bed α , and extends from the pulley b' , on a slight angle, in the direction of length of the machine, and at its outer part extends substantially at right angles to the longitudinal portion, as shown at m' , so that mail-pieces issuing from between the marking-cylinder and the belt encounter the bend m^2 between the portions m and m' of the guard, and are thereby caused to be stacked even-ended. A pair of disks n are supported in bearings on the rear side of the guard m , and are rigidly connected, so as to constitute in effect one disk, and the guard has an opening n' , through which the disk may project. Each disk is formed with a flaring throat n^2 , which, as here shown, extends tangentially or spirally, and the inner side n^3 of said throat constitutes a cam-face. The approaching mail-piece 2 is received in the throat, while the disk is in position with the inner side of the throat back of the path of the mail-piece and the base of the throat is at the bend m^2 of the guard, and that portion n^4 of the disk on the outer side of the throat holds up the pieces previously stacked against a sliding block o . As the disk rotates in the direction of the arrow, the throat recedes under the curve of the guard, leaving the mail-piece against the same, the portion n^4 of the disk leaves the stack of mail-pieces 3, while the cam-surface n^2 acts against the newly-received mail-piece and pushes it back toward the stack 3 (see Fig. 5). The outer, circular, concentric portion n^5 of the disk's periphery adds the mail-piece to the stack (see Figs. 6 and 4), and the disk returns to the position shown in Fig.

1, ready to receive the next mail-piece. An auxiliary stacker, in the form of a substantially quadrant-shaped disk p , is supported in bearings on the rear side of the guard m ; and, when the disks n are positioned to receive the mail-piece, this auxiliary disk is wholly back of the guard, and thus out of the path of the mail-piece (see Fig. 1). As the disks n rotate, the auxiliary disk p also rotates, and comes through a slot p' in the guard m , and its outer, concentric surface p^2 comes to bear on the mail at a different place in the length of the latter than the disks n (see Figs. 5 and 6), but leaves the mail-piece as the throat resumes its receiving position. This auxiliary stacker prevents that end of a mail-piece which leaves the marking devices last from remaining in the path of the following mail-piece. This auxiliary disk recedes behind the guard before the throat arrives at its receiving position. The disk is formed with a rounding cam-surface p^3 on the side which first encounters a mail-piece, to avoid a straight surface which might act on the end of a short mail-piece, whereas the opposite side extends radially, so that, when the concentric surface of the disk leaves the mail-piece, the disk more quickly recedes behind the guard. The auxiliary disk is received between the disks n .

The driving means, whereby the conveyer, the feeder, the marking-cylinder and the stackers are operated, are best shown in Fig. 3, and are of the following construction: The driving-shaft q carries three skew-gears, q^1 q^2 q^3 , which mesh respectively with corresponding gears on the journals of the marking-cylinder and the pulley b' , and on a stud which is connected by gears q^4 with the journal of the stacker-disks n , the latter being properly geared to the auxiliary stacker-disk, so that these disks will rotate in proper time with relation to the marking-cylinder and to each other.

It is evident that the invention herein disclosed can be embodied in different form from what is here shown, and is not limited in this respect.

Having thus described my invention, what I claim as new, and desire to secure by Letters Patent, is—

1. The combination with an endless conveyer, of a rotary feeding disk or table extending under the acting stretch of said conveyer, for the purpose described.

2. The combination of an endless conveyer, and rotary supports therefor having vertical axes and one of said supports carrying a horizontal table which extends across the acting stretch of the conveyer, substantially as and for the purpose described.

3. A mail-marking machine, comprising in its construction an endless conveyer, a stop to intercept the mail-pieces, a yielding finger adapted to deflect the said pieces and formed with a shoulder, and means for moving the

mail-pieces free of the stop and against the shoulder of said finger and into contact with the conveyer.

5 4. In a mail-marking machine, a rotary disk having a throat to receive the marked mail-pieces and a cam-surface for stacking the said pieces, and an auxiliary rotary stacking-disk adapted to act on a different part of a mail-piece in its length.

In testimony whereof I have signed my name to this specification, in the presence of two subscribing witnesses, this 30th day of October, A. D. 1893.

FRANK N. ETHRIDGE.

Witnesses:

A. D. HARRISON,
F. PARKER DAVIS.