



- (51) International Patent Classification:
A61F 2/14 (2006.01) A61F 9/00 (2006.01)
- (21) International Application Number:
PCT/US2014/029657
- (22) International Filing Date:
14 March 2014 (14.03.2014)
- (25) Filing Language: English
- (26) Publication Language: English
- (30) Priority Data:
61/793,241 15 March 2013 (15.03.2013) US
- (71) Applicant: **ORANGE COUNTY GLAUCOMA, PC**
[US/US]; 1200 N. Tustin Avenue, Suite 240, Santa Ana,
California 92705 (US).
- (72) Inventor: **HILL, Richard A.**; 1200 N. Tustin Avenue,
Suite 240, Santa Ana, California 92705 (US).
- (74) Agent: **HILL, James W.**; McDermott Will & Emery LLP,
4 Park Plaza, Suite 1700, Irvine, California 92614 (US).
- (81) Designated States (unless otherwise indicated, for every
kind of national protection available): AE, AG, AL, AM,
AO, AT, AU, AZ, BA, BB, BG, BH, BN, BR, BW, BY,
BZ, CA, CH, CL, CN, CO, CR, CU, CZ, DE, DK, DM,

DO, DZ, EC, EE, EG, ES, FI, GB, GD, GE, GH, GM, GT,
HN, HR, HU, ID, IL, IN, IR, IS, JP, KE, KG, KN, KP, KR,
KZ, LA, LC, LK, LR, LS, LT, LU, LY, MA, MD, ME,
MG, MK, MN, MW, MX, MY, MZ, NA, NG, NI, NO, NZ,
OM, PA, PE, PG, PH, PL, PT, QA, RO, RS, RU, RW, SA,
SC, SD, SE, SG, SK, SL, SM, ST, SV, SY, TH, TJ, TM,
TN, TR, TT, TZ, UA, UG, US, UZ, VC, VN, ZA, ZM,
ZW.

- (84) Designated States (unless otherwise indicated, for every
kind of regional protection available): ARIPO (BW, GH,
GM, KE, LR, LS, MW, MZ, NA, RW, SD, SL, SZ, TZ,
UG, ZM, ZW), Eurasian (AM, AZ, BY, KG, KZ, RU, TJ,
TM), European (AL, AT, BE, BG, CH, CY, CZ, DE, DK,
EE, ES, FI, FR, GB, GR, HR, HU, IE, IS, IT, LT, LU, LV,
MC, MK, MT, NL, NO, PL, PT, RO, RS, SE, SI, SK, SM,
TR), OAPI (BF, BJ, CF, CG, CI, CM, GA, GN, GQ, GW,
KM, ML, MR, NE, SN, TD, TG).

Published:

- with international search report (Art. 21(3))
- before the expiration of the time limit for amending the
claims and to be republished in the event of receipt of
amendments (Rule 48.2(h))

(54) Title: ENHANCEMENT OF AQUEOUS FLOW

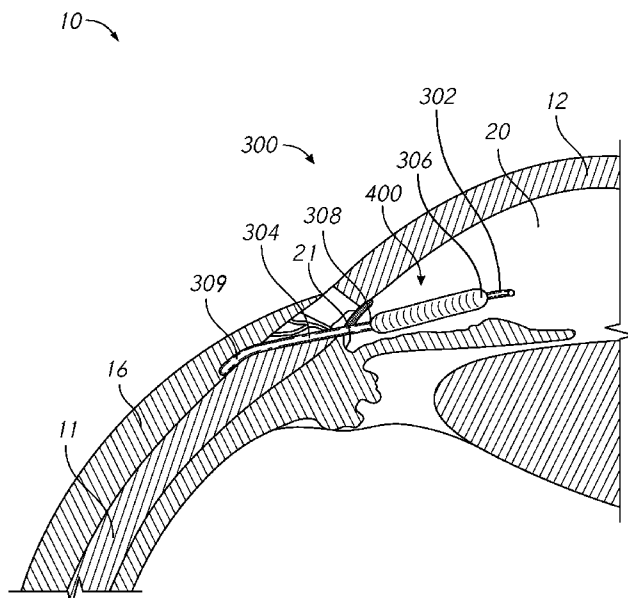

FIG. 10

(57) Abstract: Drainage of body fluid from an area of undesirably high pressure can be accomplished by interconnecting an artificial non-blood fluid conduit with the vascular system. For example, an artificial non-blood fluid conduit can be inserted into the eye to fluidly interconnect the anterior chamber with a location of lower pressure. The conduit can have a growth factor for stimulating growth of new blood vessels in the location of lower pressure to connect the new blood vessels with the non-blood fluid conduit.

WO 2014/145021 A1

ENHANCEMENT OF AQUEOUS FLOW

CROSS-REFERENCE TO RELATED APPLICATIONS

[0001] This application is a continuation of U.S. Application Serial No. 61/793,241, filed March 15, 2013, the entirety of which is hereby incorporated herein by reference.

BACKGROUND

Field of the Inventions

[0002] The present inventions relate to the enhancement of flow from a first area to a second area, which can be an area of lower pressure, in the body. More specifically, the present disclosure relates to aqueous flow, such as for treating glaucoma using pumping devices and/or a growth factor to stimulate blood vessel growth to fluidly interconnect an outflow portion of an implant, placed in the eye, with a drainage pathway.

Description of the Related Art

[0003] Aqueous humor is a transparent fluid that is secreted from the ciliary epithelium between the anterior and posterior chambers of the eye. One natural flow of aqueous humor in the eye is into the anterior chamber and out of the anterior chamber through the trabecular meshwork. It then passes through Schlemm's canal to be collected in channels at the back of Schlemm's canal. These collector channels gather together and form episcleral veins, which carry the aqueous humor out into the venous system to be circulated into the bloodstream.

SUMMARY

[0004] According to some embodiments, an intraocular implant can be provided that is configured to facilitate or stimulate blood vessel growth in order to fluidly interconnect the implant with a plurality of new blood vessels. The implant can comprise an inflow region or shunt that can be positioned in fluid communication with (e.g., extending into) the anterior chamber on the surface of the eye and an outflow region or shunt extending into a region of lower pressure of the eye, such as a subconjunctival space, a suprachoroidal space, or a supraciliary space of the eye.

[0005] In some embodiments, the methods and apparatuses disclosed herein provide a manner of facilitating outflow of aqueous humor through an implant from the anterior chamber to a location of lower pressure by developing new episcleral veins adjacent to an outlet portion of the implant in the location of lower pressure.

[0006] In some embodiments, methods and apparatuses are provided for fluidly interconnecting blood vessels with non-blood artificial conduits.

[0007] The subject technology is illustrated, for example, according to various aspects described below. Various examples of aspects of the subject technology are described as numbered clauses (1, 2, 3, etc.) for convenience. These are provided as examples and do not limit the subject technology. It is noted that any of the dependent clauses may be combined in any combination, and placed into a respective independent clause, e.g., clause 1 or clause 5. The other clauses can be presented in a similar manner.

[0008] Clause 1. An intraocular implant comprising: a first tubular member having an inlet and an outlet; a pump body having an inlet and an outlet, the inlet being in fluid communication with the first tubular member outlet, the pump body further comprising a pumping chamber configured to resiliently expand from a compressed state to create a suction force at the first tubular member inlet, the pump body being compressible to expel fluid from the pump body outlet; a first one-way valve coupled to the first tubular member for permitting inflow into the first tubular member inlet and into the pump body inlet; a second tubular member having an inlet and an outlet, the inlet being in fluid communication with the pump body outlet to receive expelled fluid therefrom; and a second one-way valve coupled to the second tubular member for permitting flow into the second tubular member inlet and out through the second tubular member outlet.

[0009] Clause 2. The implant of Clause 1, wherein the first one-way valve is positioned adjacent to the first tubular member outlet.

[0010] Clause 3. The implant of any of Clauses 1 to 2, wherein the second one-way valve is positioned adjacent to the second tubular member inlet.

[0011] Clause 4. The implant of any of Clauses 1 to 3, wherein the pump body comprises a pumping surface area of from about 1 mm² to about 40 mm².

[0012] Clause 5. The implant of any of Clauses 1 to 4, wherein the second tubular member comprises a growth factor.

[0013] Clause 6. The implant of Clause 5, wherein the growth factor is coated onto an outlet portion of the second tubular member.

[0014] Clause 7. The implant of Clause 5, wherein the second tubular member comprises an outlet portion formed from a resorbable material, and wherein the growth factor is impregnated into the resorbable material.

[0015] Clause 8. The implant of any of Clauses 1 to 7, wherein the pump body is compressible using a pulsed pressure of at least 7 mm Hg.

[0016] Clause 9. The implant of Clause 8, wherein the pump body is compressible using a pulsed pressure of at least 10 mm Hg.

[0017] Clause 10. The implant of Clause 9, wherein the pump body is compressible using a pulsed pressure of at least 13 mm Hg.

[0018] Clause 11. The implant of any of Clauses 1 to 10, wherein the first tubular member is configured to be inserted into an anterior chamber of an eye, and the second tubular member is configured to extend through a trabecular meshwork and/or sclera of the eye to an outflow space.

[0019] Clause 12. The implant of any of Clauses 1 to 11, wherein the outflow space comprises at least one of a supraciliary space, an intrascleral space, a suprachoroidal space, a subconjunctival space, episcleral veins, aqueous collector channels, or Schlemm's canal.

[0020] Clause 13. An intraocular implant comprising: a tubular member having an inlet region configured to extend into an anterior chamber of an eye, and a vascular connecting outlet region (i) extending along a portion of the tubular member and configured to extend into an outflow space comprising at least one of a supraciliary space, an intrascleral space, a suprachoroidal space, a subconjunctival space, episcleral veins, aqueous collector channels, or Schlemm's canal; and a growth factor carried by the vascular connecting outlet region.

[0021] Clause 14. The implant of Clause 13, wherein the vascular connecting region comprises at least about half of a length of the tubular member.

[0022] Clause 15. The implant of any of Clauses 13 to 14, wherein the vascular connecting region comprises at least about a third of a length of the tubular member.

[0023] Clause 16. The implant of any of Clauses 13 to 15, wherein the vascular connecting region comprises at least about a fourth of a length of the tubular member.

[0024] Clause 17. The implant of any of Clauses 13 to 16, wherein the vascular connecting region comprises at least about a fifth of a length of the tubular member.

[0025] Clause 18. The implant of any of Clauses 13 to 17, wherein the vascular connecting region comprises at less than about a fifth of a length of the tubular member.

[0026] Clause 19. The implant of any of Clauses 13 to 18, wherein the vascular connecting region comprises a plurality of recesses configured to carry the growth factor therein.

[0027] Clause 20. The implant of any of Clauses 13 to 19, wherein the growth factor comprises a vascular growth factor.

[0028] Clause 21. The implant of Clause 20, wherein the growth factor comprises a VEGF.

[0029] Clause 22. The implant of any of Clauses 13 to 21, wherein the vascular connecting region comprises a resorbable material and a least a portion of the growth factor.

[0030] Clause 23. The implant of Clause 22, wherein the vascular connecting region comprises a non-resorbable polymeric material and a plurality of apertures extending in a direction transverse to the stent lumen, the plurality of apertures comprising a resorbable material and the growth factor disposed therein.

[0031] Clause 24. The implant of Clause 23, wherein the plurality of apertures extend along an entire length of the vascular connecting region.

[0032] Clause 25. The implant of any of Clauses 13 to 24, wherein the vascular connecting region is formed from a resorbable material, and the growth factor is impregnated into the resorbable material.

[0033] Clause 26. The implant of any of Clauses 13 to 25, wherein the growth factor comprises a coating on the vascular connecting region.

[0034] Clause 27. The implant of any of Clauses 13 to 26, further comprising a pump for urging fluid through the implant.

[0035] Clause 28. The implant of Clause 27, wherein the pump is configured to operate using ocular pulse pressure.

[0036] Clause 29. The implant of Clause 28, wherein the pump comprises a one-way valve.

[0037] Clause 30. The implant of any of Clauses 13 to 29, further comprising a one-way valve for facilitating fluid flow through the implant.

[0038] Clause 31. An intraocular implant comprising: a tubular member having an inlet region configured to extend into an anterior chamber of an eye, and a vascular connecting outlet region (i) extending along a portion of the tubular member and configured to extend into an outflow space comprising at least one of a supraciliary space, an intrascleral space, a suprachoroidal space, a subconjunctival space, episcleral veins, aqueous collector channels, or Schlemm's canal; and a pump mechanism fluidly coupled to the inlet region, the pump mechanism having a pumping chamber that defines a pumping surface area of from about 1 mm² to about 40 mm².

[0039] Clause 32. The implant of Clause 31, wherein the pumping surface area is from about 1 mm² to about 25 mm².

[0040] Clause 33. The implant of any of Clauses 31 to 32, wherein the pumping surface area is from about 1 mm² to about 15 mm².

[0041] Clause 34. The implant of any of Clauses 31 to 33, wherein the pumping surface area is from about 1 mm² to about 10 mm².

[0042] Clause 35. A method of deploying an intraocular implant into an eye for stimulating vascular growth, the method comprising: inserting into the eye a deployment member carrying the implant; releasing the implant from the deployment member such that an inflow region of the implant resides in a higher pressure chamber of the eye and a vascular connecting region of the implant resides in a location of lower pressure chamber of the eye, the implant having a lumen to conduct fluid therethrough, the vascular connecting region of the implant carrying a growth factor for promoting growth of blood vessels adjacent to the vascular connecting region within the lower pressure chamber to facilitate aqueous humor outflow from the higher pressure chamber; and withdrawing the deployment member from the eye.

[0043] Clause 36. The method of Clause 35, wherein the growth factor comprises a vascular growth factor selected from the group consisting of a VEGF isoform.

[0044] Clause 37. The method of any of Clauses 35 to 36, wherein the growth factor comprises a VEGF.

[0045] Clause 38. The method of any of Clauses 35 to 37, wherein the lower pressure chamber comprises at least one of a supraciliary space, an intrascleral space, a suprachoroidal space, a subconjunctival space, episcleral veins, aqueous collector channels, or Schlemm's canal.

[0046] Clause 39. The method of any of Clauses 35 to 38, wherein the higher pressure chamber comprises the anterior chamber.

[0047] Clause 40. The method of any of Clauses 35 to 39, wherein the vascular connecting region comprises a resorbable material and a least a portion of the growth factor.

[0048] Clause 41. The method of Clause 40, wherein the vascular connecting region comprises a non-resorbable polymeric material having a plurality of apertures extending in a direction transverse to the stent lumen, the plurality of apertures comprising a resorbable material and the growth factor disposed therein.

[0049] Clause 42. The method of any of Clauses 40 to 41, wherein the growth factor is impregnated into the resorbable material.

[0050] Clause 43. The method of any of Clauses 35 to 42, wherein the growth factor is impregnated into the vascular connecting region.

[0051] Clause 44. The method of Clause 43, wherein the vascular connecting region comprises a resorbable material.

[0052] Clause 45. The method of any of Clauses 35 to 44, wherein the growth factor comprises a coating on the vascular connecting region.

[0053] Clause 46. A method of placing an intraocular implant for stimulating vascular growth, the method comprising implanting the implant into the eye such that a non-resorbable portion of the implant resides in a higher pressure chamber of the eye and a resorbable portion resides in a location of lower pressure chamber of the eye, the implant having a lumen extending therethrough, the resorbable portion comprising a growth factor for stimulating growth of new blood vessels, the resorbable portion configured to dissolve such that the new blood vessels converge toward the implant non-resorbable portion extending from the higher pressure chamber of the eye thereby enabling the implant lumen to be in fluid communication with the new blood vessels to facilitate aqueous humor outflow from the higher pressure chamber.

[0054] Clause 47. The method of Clause 46, wherein the growth factor comprises a vascular growth factor.

[0055] Clause 48. The method of Clause 47, wherein the growth factor comprises a VEGF.

[0056] Clause 49. The method of any of Clauses 46 to 48, wherein the lower pressure chamber comprises at least one of a supraciliary space, an intrascleral space, a suprachoroidal space, a subconjunctival space, episcleral veins, aqueous collector channels, or Schlemm's canal, and the growth factor promotes growth of episcleral veins.

[0057] Clause 50. The method of any of Clauses 46 to 49, wherein the higher pressure chamber comprises the anterior chamber.

[0058] Clause 51. A method of facilitating drainage of aqueous humor from a higher pressure chamber to a lower pressure chamber of an eye, the method comprising inserting an artificial non-blood fluid conduit into the eye to fluidly interconnects the higher pressure chamber with the lower pressure chamber, the conduit having a growth factor for stimulating growth of new blood vessels adjacent the lower pressure chamber to connect the new blood vessels with the non-blood fluid conduit.

[0059] Clause 52. The method of Clause 51, wherein the higher pressure chamber comprises the anterior chamber.

[0060] Clause 53. The method of any of Clauses 51 to 52, wherein the lower pressure chamber comprises at least one of a supraciliary space, an intrascleral space, a suprachoroidal space, a subconjunctival space, episcleral veins, aqueous collector channels, or Schlemm's canal.

[0061] Clause 54. A method of deploying an intraocular implant into an eye, the method comprising: inserting into the eye a deployment member carrying the implant of any of Clauses 1 to 34; releasing the implant from the deployment member such that (i) an inflow region of the implant resides in an anterior chamber of the eye, (ii) a pump body is positioned in subconjunctival space, and (iii) an outflow region resides in the subconjunctival space; and withdrawing the deployment member from the eye.

[0062] Clause 55. The method of Clause 54, wherein the inserting comprises piercing the cornea to perform the method ab interno.

[0063] Clause 56. The method of any of Clauses 54 to 55, wherein the inserting comprises advancing the deployment member through sclera to perform the method ab externo.

[0064] Clause 57. The method of any of Clauses 54 to 56, wherein the releasing comprises positioning the pump body between the cornea and a rectus muscle of the eye.

[0065] Clause 58. The method of any of Clauses 54 to 58, wherein the outflow region comprises a growth factor.

[0066] Clause 59. The method of Clause 58, wherein the growth factor comprises a VEGF.

[0067] Clause 60. The method of any of Clauses 54 to 59, wherein the higher pressure chamber comprises the anterior chamber.

[0068] Clause 61. The method of any of Clauses 54 to 60, wherein the lower pressure chamber comprises at least one of a supraciliary space, an intrascleral space, a suprachoroidal space, a subconjunctival space, episcleral veins, aqueous collector channels, or Schlemm's canal.

[0069] Clause 62. An implant comprising any of the features or structures disclosed herein.

[0070] Clause 63. A method of placing an implant comprising: placing an implant having any of the features or structures disclosed herein; and placing the implant to interconnect any of the bodily spaces disclosed herein with a location of lower pressure.

[0071] Additional features and advantages of the subject technology will be set forth in the description below, and in part will be apparent from the description, or may be learned by practice of the subject technology. The advantages of the subject technology will be realized and attained by the structure particularly pointed out in the written description and embodiments hereof as well as the appended drawings.

[0072] It is to be understood that both the foregoing general description and the following detailed description are exemplary and explanatory and are intended to provide further explanation of the subject technology.

BRIEF DESCRIPTION OF THE DRAWINGS

[0073] Various features of illustrative embodiments of the inventions are described below with reference to the drawings. The illustrated embodiments are intended to illustrate, but not to limit, the inventions. The drawings contain the following figures:

[0074] Figure 1 is a cross-sectional view of an eye.

[0075] Figure 2 is a perspective view of an implant, according to some embodiments.

[0076] Figure 3 is a perspective view of another implant having a pump mechanism, according to some embodiments.

[0077] Figure 4 is a schematic view of an implant implanted in an eye, according to some embodiments.

[0078] Figures 5–6 illustrate embodiments of an outlet portion of an implant.

[0079] Figures 7–9 illustrate dissolution of a growth-factor-impregnated vascular portion of an implant and the progressive development of new blood vessels, according to some embodiments.

[0080] Figure 10 illustrates placement of an implant in an eye, according to some embodiments.

[0081] Figures 11–12 illustrate additional embodiments of implants incorporating a pump mechanism, according to some embodiments.

[0082] Figures 13–14 illustrate front and cross-sectional views of an eye in which an implant has been placed, according to some embodiments.

DETAILED DESCRIPTION

[0083] In the following detailed description, numerous specific details are set forth to provide a full understanding of the subject technology. It should be understood that the subject technology may be practiced without some of these specific details. In other instances, well-known structures and techniques have not been shown in detail so as not to obscure the subject technology.

[0084] Further, while the present description sets forth specific details of various embodiments, it will be appreciated that the description is illustrative only and should not be construed in any way as limiting. Furthermore, various applications of such embodiments and modifications thereto, which may occur to those who are skilled in the art, are also encompassed by the general concepts described herein.

[0085] Figure 1 illustrates a cross-sectional view of an eye 10. Thick collagenous tissue known as sclera 11 covers the entire eye 10 except that portion covered by the cornea 12. The cornea 12 is a thin transparent tissue that focuses and transmits light into the eye and the pupil 14 which is the circular hole in the center of the iris 13

(colored portion of the eye). The cornea 12 merges into the sclera 11 at a juncture referred to as the limbus 15. The conjunctiva 16 is a thin membrane that covers the sclera 11 and cornea 12. The ciliary epithelium begins internally in the eye and extends along the interior of the sclera 11 and becomes the choroid 17. The choroid 17 is a vascular layer of the eye underlying retina 18. The optic nerve 19 transmits visual information to the brain.

[0086] The anterior chamber 20 of the eye 10, which is bound anteriorly by the cornea 12 and posteriorly by the iris 13 and lens 26, is filled with aqueous humor. Aqueous humor is a transparent fluid that is secreted from the ciliary epithelium between the anterior and posterior chambers of the eye. The natural flow of aqueous humor in the eye is into the anterior chamber 20 and out of the anterior chamber through the trabecular meshwork 21. It then passes through Schlemm's canal 22 to be collected in channels at the back of Schlemm's canal 22. These collector channels gather together and form episcleral veins, which carry the aqueous humor out into the venous system to be circulated into the bloodstream.

[0087] Intraocular pressure of the eye 10 is maintained by the intricate balance of secretion and outflow of the aqueous in the manner described above. Glaucoma is characterized by the excessive buildup of aqueous fluid in the anterior chamber 20 which produces an increase in intraocular pressure (fluids are relatively incompressible and pressure is directed equally to all areas of the eye). The optic nerve 19 can be sequentially destroyed by glaucoma.

Implant Structures and Methods

[0088] According to some embodiments, an intraocular implant can be provided that is configured to facilitate or stimulate blood vessel growth in order to fluidly interconnect the implant with a plurality of new blood vessels. Figures 2–3 illustrate embodiments of implants 50, 60 that can comprise an inflow region 52, 62 that can be positioned in fluid communication with (e.g., extending into) the anterior chamber of the eye and a vascular connecting region 54, 64 extending into a region of lower pressure of the eye.

[0089] The implant 50, 60 can comprise a tubular or other shaped hollow member that can imbibe water. The implant 50, 60 can optionally comprise a porous material. The implant 50, 60 can be an aqueous transport member.

[0090] The vascular connecting region 54, 64 can be any suitable length or portion of the implant. In some embodiments, the vascular connecting region can extend externally, such as into the sclera.

[0091] In some embodiments, the methods and apparatuses disclosed herein provide a manner of facilitating outflow of aqueous humor through an implant from the anterior chamber to a location of lower pressure by developing new episcleral veins adjacent to the vascular connecting region of the implant in the location of lower pressure. The methods and apparatus can be inserted ab interno or ab externo. Ab interno surgery involves piercing the cornea and advancing the implant into the eye tissue, such as the anterior chamber angle or sclera, such that an inflow region of the implant resides in a higher pressure chamber and an outflow region resides in a lower pressure chamber. In contrast, ab externo surgery involves piercing the eye tissue, such as sclera, and advancing the implant through sclera and into fluid communication with the lower pressure chamber, such that an inflow region of the implant resides in a higher pressure chamber and an outflow region resides in a lower pressure chamber.

Growth Factors

[0092] In accordance with some embodiments, the implant can comprise a growth factor. The growth factor can be carried by the implant, such as on an outflow portion or shunt, as a coating on the implant and/or incorporated into the material of the implant. As illustrated in Figure 4, an implanted shunt 80 having a growth factor disposed thereon can stimulate growth of new blood vessels 82, as discussed herein.

[0093] In accordance with some embodiments, the growth factor can stimulate growth of blood vessels and/or aqueous collector channels.

[0094] Figure 4 illustrates that, in some embodiments, the shunt 80 can comprise a vascular connecting region 92. The vascular connecting region 92 can comprise the growth factor. The vascular connecting region 92 can extend along an outlet end portion of the shunt. The vascular connecting region 92 can comprise any portion of the shunt, such as about one-half, one-third, one-fourth, one-fifth, one-sixth, one-seventh, or less of the overall shunt length.

[0095] In some embodiments, the growth factor can comprise a vascular endothelial growth factor (VEGF). VEGF is a sub-family of growth factors, and specifically, the platelet-derived growth factor family of cystine-knot growth factors.

VEGF is an important signaling proteins involved in both vasculogenesis (the de novo formation of the embryonic circulatory system) and angiogenesis (the growth of blood vessels from pre-existing vasculature).

[0096] VEGF can be produced by certain organs to restore the oxygen supply to tissues when blood circulation is inadequate. For example, VEGF's normal function is to create new blood vessels during embryonic development, new blood vessels after injury, muscle following exercise, and new vessels (collateral circulation) to bypass blocked vessels.

[0097] For example, included within the family of VEGF, VEGF-A can facilitate angiogenesis, including the migration of endothelial cells, mitosis of endothelial cells, methane monooxygenase activity, $\alpha\beta 3$ activity, creation of blood vessel lumens, creation of fenestrations, chemotactic for macrophages and granulocytes, and vasodilation (indirectly by NO release). Further, VEGF-B can facilitate embryonic angiogenesis (e.g., in myocardial tissue). VEGF-C can facilitate lymphangiogenesis. VEGF-D can facilitate the development of lymphatic vasculature surrounding lung bronchioles. Further, PlGF can facilitate vasculogenesis and be used for angiogenesis during ischemia, inflammation, wound healing, and cancer.

[0098] Further, the broad term VEGF covers a number of proteins from two families, that result from alternate splicing of mRNA from a single, 8-exon, VEGF gene. The two different families are referred to according to their terminal exon (exon 8) splice site—the proximal splice site (denoted VEGFxxx) or distal splice site (VEGFxxx_b). In addition, alternate splicing of exon 6 and 7 alters their heparin-binding affinity, and amino acid number (in humans: VEGF121, VEGF121_b, VEGF145, VEGF165, VEGF165_b, VEGF189, VEGF206; the rodent orthologs of these proteins contain one fewer amino acid). These domains have important functional consequences for the VEGF splice variants, as the terminal (exon 8) splice site determines whether the proteins are pro-angiogenic (proximal splice site, expressed during angiogenesis) or anti-angiogenic (distal splice site, expressed in normal tissues). In addition, inclusion or exclusion of exons 6 and 7 mediate interactions with heparan sulfate proteoglycans (HSPGs) and neuropilin co-receptors on the cell surface, enhancing their ability to bind and activate the VEGF receptors (VEGFRs). Recently, VEGF-C has been shown to be an important inducer of neurogenesis in the murine subventricular zone, without exerting angiogenic effects.

[0099] However, VEGF can contribute to disease when it is overexpressed. For example, solid cancers cannot grow beyond a limited size without an adequate blood supply; cancers that can express VEGF are able to grow and metastasize. Further, overexpression of VEGF can contribute to macular degeneration, such as age-related macular degeneration (AMD) and vascular disease in the retina of the eye and other parts of the body.

[0100] Accordingly, although growth factors are known, the prior art does not teach the use of growth factors in the eye. Instead, the prior art teaches the use of drugs, such as anti-VEGF, in the eye to impede growth of blood vessels.

[0101] Anti-VEGF therapies are important to stop new blood vessel growth in cancers and in other eye diseases, such as diabetic retinopathy or macular degeneration. Such therapies can use drugs such as Ranibizumab (Lucentis™), Bevacizumab (Avastin®), lapatinib (Tykerb), sunitinib (Sutent), sorafenib (Nexavar), axitinib, pazopanib, THC, and Cannabidiol, can inhibit VEGF and control or slow cancers or diseases such as AMD. For example, Lucentis™ is an antibody that can be injected into the eye to bind to a VEGF, inactivate a VEGF, and stop new blood vessel growth. The use of products such as Lucentis™ allows a clinician to mitigate or prevent metastasizing of cancer cells. Accordingly, current therapies for macular degeneration, for example, therefore relies on anti-VEGF therapy.

[0102] Therefore, in the context of eye diseases, VEGF has been considered undesirable and therapy using growth factors such as a VEGF would not be considered desirable or obvious to a person of skill. As noted above, the body's own development of a VEGF in the eye occurs with disease, such as diabetic retinopathy and macular degeneration. In these diseases, the body forms new blood vessels on the retina. These blood vessels are bad because they can bleed, leak fluid, and cause sub-retinal fluid collections, retinal detachment, hemorrhaging, and blindness, especially when it is on the macula. Accordingly, a clinician would attempt to stop blood vessel growth by administering drugs such as Lucentis™.

[0103] Additionally, VEGF can be used to overcome harmful conditions of the heart, such as to connect blood vessels with blood vessels in situations where a coronary heart vessel has been blocked by plaque. For example, a VEGF is naturally produced by the heart over time to develop collateral vessels that mitigate vessel blockages. These collaterals are created very slowly over the course of a person's lifetime.

However, although this function and use of a VEGF may be encouraging, Applicant recognizes that this use is exclusively limited to connecting new blood vessels with existing blood vessels. However, there are no methods or apparatuses known in the art that facilitate connection between new blood vessels and artificial fluid conduits, such as non-blood fluid conduits.

[0104] Accordingly, some embodiments disclosed herein provide novel methods and systems for developing flow pathways using a growth factor to relieve intraocular pressure. As noted, the methods and apparatuses disclosed herein can use a growth factor, such as a VEGF. Some embodiments can use a protein, such as a VEGF, which can be impregnated or encoded with a gene. For example, a VEGF is a class of a protein that is encoded by a gene. Various types of a VEGF can be formulated and used in some embodiments.

[0105] A listing of growth factor protein families from which one or more growth factors can be used in accordance with some embodiments, include: Adrenomedullin (AM); Angiopoietin (Ang); Autocrine motility factor; Bone morphogenetic proteins (BMPs); Brain-derived neurotrophic factor (BDNF); Epidermal growth factor (EGF); Erythropoietin (EPO); Fibroblast growth factor (FGF); Glial cell line-derived neurotrophic factor (GDNF); Granulocyte colony-stimulating factor (G-CSF); Granulocyte macrophage colony-stimulating factor (GM-CSF); Growth differentiation factor-9 (GDF9); Hepatocyte growth factor (HGF); Hepatoma-derived growth factor (HDGF); Insulin-like growth factor (IGF); Migration-stimulating factor; Myostatin (GDF-8); Nerve growth factor (NGF) and other neurotrophins; Platelet-derived growth factor (PDGF); Thrombopoietin (TPO); Transforming growth factor alpha(TGF- α); Transforming growth factor beta(TGF- β); Tumor_necrosis_factor-alpha(TNF- α); Vascular endothelial growth factor (VEGF); Wnt Signaling Pathway; placental growth factor (PIGF); [(Foetal Bovine Somatotrophin)] (FBS); IL-1 Cofactor for IL-3 and IL-6 (activates T cells); IL-2 T-cell growth factor (stimulates IL-1 synthesis and activates B-cells and NK cells); IL-3 (stimulates production of all non-lymphoid cells); IL-4 (growth factor for activated B cells, resting T cells, and mast cells); IL-5 (induces differentiation of activated B cells and eosinophils); IL-6 (stimulates Ig synthesis and growth factor for plasma cells); IL-7 (growth factor for pre-B cells), as well as other known or developed growth factors. VEGF-related proteins can include: VEGF-A, VEGF-B, VEGF-C, VEGF-D, VEGF isoforms, or other related proteins.

[0106] Some embodiments provide that a sequence identity to a gene or protein can be at least about 80%. For example, the sequence identity can be at least about 90%. Further, in some embodiments, the sequence identity can be at least about 95%. The sequence can be of base pairs if it is a gene or DNA, or the sequence can be amino acids if it is a protein. Some embodiments can use VEGF, the protein. Sequence identities for VEGF-A, VEGF-B, VEGF-C, and VEGF-D can be those such as disclosed in U.S. Application Serial No. 61/793,241, filed March 15, 2013, the entirety of which is hereby incorporated herein by reference.

[0107] Figure 4 illustrates that, in some embodiments, the shunt 80 can be implanted such that a vascular connecting region 92 can be implanted into an area of lower pressure than the anterior chamber. For example, the area of lower pressure can be in the subconjunctival space, the suprachoroidal space, or the supraciliary space. Thus, the outflow portion or end of the implant can be implanted into the subconjunctival space, the suprachoroidal space, or the supraciliary space and with the growth factor, facilitate growth of new blood vessels such that the implant can directly connect with blood vessels in the subconjunctival space, the suprachoroidal space, and/or the supraciliary space.

[0108] In such embodiments, the ocular implant can facilitate direct the fluid interconnection with blood vessels in the subconjunctival space, the suprachoroidal space, and/or the supraciliary space, much further beyond simply permitting diffusion into these areas. For embodiments in which the implant outflow end is positioned in the suprachoroidal or supraciliary space, the implant can be inserted through the sclera into the suprachoroidal space and the implant could be positioned over the ciliary body to over pars plana. Other ab interno methods can also be performed.

[0109] The vascular connecting region 92 can comprise a growth factor, such as one or more of those listed herein. In some embodiments, the growth factor can be disposed or coated on the vascular connecting region 92. In other embodiments, the vascular connecting region 92 can comprise a resorbable material (as discussed further below) and the growth factor can be incorporated or impregnated into the resorbable material.

[0110] As with any of the ocular implants disclosed herein, the shunt 80 can be placed by an ab interno or an ab externo method. Thus, a deployment member carrying the shunt 80 can be inserted into the cornea (in an ab interno method), the vascular

connecting region 92 of the shunt 80 can be positioned in the subconjunctival space, and the deployment member can thereafter be withdrawn.

[0111] For example, Figure 10 illustrates that the implant can be delivered through the anterior chamber angle, the trabecular meshwork, and into a subconjunctival space of the eye, according to some embodiments.

[0112] After implantation of the shunt, the growth factor can begin to initiate or stimulate growth of new blood vessels 82. The new blood vessels 82 can provide an enhanced outflow pathway for aqueous humor draining from the anterior chamber.

Resorbable Materials

[0113] As noted above, in some embodiments, the vascular connecting region of the implant or shunt can comprise a resorbable portion. Figures 5 and 6 illustrate shunts 100, 150 that comprise an optional resorbable portion 102, 152 in the vascular connecting region 104, 154. In some embodiments, the vascular connecting region 104, 154 can be entirely resorbable. For example, the resorbable portion 102, 152 can comprise a collagen. Further, in some embodiments, the resorbable portion 102, 152 can comprise the growth factor, such as VEGF or other growth factor that is configured to facilitate growth of blood vessels. For example, the resorbable portion 102, 152 can comprise a collagen that holds or is impregnated with the growth factor.

[0114] Additionally, the resorbable portion 102, 152 can extend across any length or amount of the vascular connecting region or shunt length. The resorbable portion 102, 152 of the shunt 100, 150 can comprise from about 1/10 to about 1/2 of the length of the shunt. In some embodiments, the resorbable portion 102, 152 can comprise 1/8 to about 1/3 of the length of the shunt. Additionally, the resorbable portion 102, 152 can comprise about 1/6 to about 1/4 of the length of the shunt. For example, the resorbable portion 102, 152 can comprise about 1/5 to about 1/3 of the length of the shunt.

[0115] In some embodiments, the vascular connecting region of the shunt can be only partially resorbable. For example, the shunt can have at least some non-resorbable material extending over its entire length. For example, Figure 6 illustrates that the resorbable portion 152 can comprise a portion of the vascular connecting region 154. In some embodiments, the vascular connecting region 154 can be formed from a non-resorbable polymeric material having a series of apertures or recesses that accommodate a

resorbable material, as illustrated in Figure 6. The resorbable portion 152 can be impregnated with a growth factor, such as a VEGF, and in use, the resorbable material can be dissolved into the tissue and release the growth factor. However, the growth factor can also or alternatively be carried in a coating disposed on the non-resorbable material and/or the resorbable material such that new blood vessel growth is promoted as the coating dissolves.

[0116] In accordance with some embodiments, the resorbable material can dissolve into a region of the eye within a range of from about two weeks to about 12 weeks. Further, the resorbable material can dissolve within a range of from about four weeks to about 10 weeks. Furthermore, the resorbable material can dissolve within a range of from about six weeks to about eight weeks.

[0117] For example, Figures 7–9 illustrate an implant (a shunt 200) implanted into an eye and the progressive development of new blood vessel growth 202 from a growth factor that was impregnated into a resorbable portion of the shunt 200. Further, although Figures 7–9 illustrate resorption of a portion of the shunt 200, in some embodiments, the shunt can be coated with a growth factor to facilitate growth of new blood vessels.

Pump Mechanisms

[0118] In accordance with some embodiments, the implant can comprise a pump mechanism. The pump mechanism can be configured to draw fluid from the anterior chamber toward another location of the eye. In some embodiments, the pump mechanism can be used in combination with the growth factor, which can allow the pump mechanism to draw fluid from the anterior chamber toward newly formed or growing episcleral veins. Pump-type implants can be implanted into the eye using either the ab interno or the ab externo placement procedure.

[0119] The implant can be configured to comprise a pump mechanism coupled to one or more tubular shunts. For example, the pump mechanism can comprise an inlet and an outlet. In some embodiments, the outlet can be coupled to a tubular shunt. Further, in some embodiments, the inlet can be coupled to a tubular shunt. Furthermore, in some embodiments, each of the inlet and the outlet can be coupled to a respective tubular shunt. The use of tubular shunts and combination with the pump mechanism can enable embodiments of the ocular implant to position the pump mechanism at a location

that permits the most effective use of the pump mechanism. In addition, such embodiments can advantageously collect and/or distribute the aqueous humor to any location regardless of the location of the pump mechanism.

[0120] In some embodiments, the pump mechanism can be positioned within the anterior chamber (e.g., see Figures 4 and 10) or outside of the anterior chamber, such as in the subconjunctival space (e.g., see Figures 13-14), the suprachoroidal space, and/or the supraciliary space.

[0121] In some embodiments, the position or location of the pump mechanism can advantageously be independent of the outflow location for the implant, thereby allowing the outflow portion of the implant to utilize a growth factor to stimulate growth of new blood vessels. Thus, the pump mechanism can be positioned in a variety of locations depending on the desired pump actuation (whether e.g., the pump is actuated mechanically or by a radiofrequency (RF)) and the outflow portion of the implant can extend into the subconjunctival space, the suprachoroidal space, or supraciliary space.

[0122] For example, the pump mechanism can be placed in the subconjunctival space and an outflow shunt, coupled to the outlet of the pump mechanism, can extend into the subconjunctival space, the suprachoroidal space, or supraciliary space. In such embodiments, an inlet of the pump mechanism can be coupled to an inflow shunt that extends into the anterior chamber.

[0123] Further, the pump mechanism can be placed in the anterior chamber and an outflow shunt, coupled to the outlet of the pump mechanism, can extend into the subconjunctival space, the suprachoroidal space, or supraciliary space.

[0124] Furthermore, the pump mechanism can be placed in the the suprachoroidal space or supraciliary space and an outflow shunt, coupled to the outlet of the pump mechanism, can extend into the subconjunctival space, the suprachoroidal space, or supraciliary space. In such embodiments, an inlet of the pump mechanism can be coupled to an inflow shunt that extends into the anterior chamber.

[0125] In any of the above-noted placement combinations, the ocular implant can optionally incorporate other structural components or features disclosed herein, such as growth factors, resorbability, valves, or pump mechanism features.

[0126] Referring now to Figure 10, the pump can be interconnected with a shunt. Figure 10 illustrates an implant 300 having a pump mechanism 400 coupled to an inlet portion or shunt 302 and an outlet portion or shunt 304. The inlet shunt 302 can be

coupled to an inlet 306 of the pump mechanism 400, and the outlet shunt 304 can be coupled to an outlet 308 of the pump mechanism 400. The shunt 304 can comprise a vascular connecting portion 309 at the outlet 306.

[0127] Various illustrations of embodiments of a pump mechanism 400 are shown in the figures. For example, Figures 3, 4, 10, 11, and 12 illustrate embodiments of an ocular implant that incorporate a pump, generally referred to as element 400. Figure 4 also illustrates a top view through the cornea.

[0128] The pump mechanism can comprise a pliable, resilient balloon-type structure. The pump mechanism can be formed into any of a variety of three-dimensional shapes, such as a cylinder or tube, a prism (such as a hollow pad having generally flat, wide faces that are spaced apart from each other at a distance much less than a width of the pad), an annulus, and combinations thereof. Further, the pump mechanism 400 can include one or more pumping chambers that are in fluid communication with one or more inlets and one or more outlets.

[0129] In some embodiments, the pump mechanism can have an inlet that extends into, along, or adjacent to the trabecular meshwork and/or the anterior chamber. The inlet can function similar to the atria (low pressure side) of the heart. For example, Figure 11 illustrates an embodiment of a pump mechanism 400 that can comprise a generally annular body 350.

[0130] The pump mechanism can comprise one or more balloons having a total surface area of from about 1 mm² to about 110 mm². Some embodiments can be configured such that the surface area of the pump is from about 5 mm² to about 70 mm². Some embodiments can be configured such that the surface area of the pump is from about 8 mm² to about 50 mm². Further, the surface area of the pump is from about 10 mm² to about 30 mm². In some embodiments, the surface area of the pump is from about 12 mm² to about 20 mm².

[0131] In some embodiments, a surface of the pump mechanism can comprise one or more microstructures, such as plications or microvilli to increase the surface area of the pump mechanism 400. For example, the surface area of a balloon can be increased substantially by the use of plications (in some embodiments, the surface area can be increased by up to 1 mm², 2 mm², 3 mm², 4 mm², 5 mm², 6 mm², 7 mm², or more mm² per plication, as desired).

[0132] According to some embodiments, the surface area of the pump mechanism can be patterned after the surface area of the trabecular meshwork. For example, the surface area of the pump can be about equal to or greater than the surface area of a trabecular meshwork. Approximating the size of the pump to the size of the trabecular meshwork can enable embodiments disclosed herein to provide a rate of fluid disposal that is similar to that of the trabecular meshwork.

[0133] For example, the surface area of the trabecular meshwork can be generally approximated to the surface area of a biconcave disk having a diameter of about 12 mm (approximated using a surface area of a two-sided flat disc, $2\pi d$), which provides a total surface area of about 72 mm^2 . It is anticipated that the surface area of a trabecular meshwork will vary, possibly by as much as 50%, from 72 mm^2 , such that the total surface area of a trabecular meshwork can be approximated as from 36 mm^2 to about 108 mm^2 .

[0134] The surface area of the pump and the surface area of a trabecular meshwork can be related as a ratio of from about 0.2:1 to about 4:1. In some embodiments, the ratio can be about 0.25:1 to about 3:1. The ratio can also be from about one third to one to about 2:1. The ratio can also be from about 0.4:1 to about 1:1. The ratio can be from about 0.5:1 to about 0.9:1. The ratio can also be from about 0.6:1 to about 0.8:1. Further, the ratio can be about 0.75:1.

[0135] In accordance with some embodiments, the pump mechanism can be operated by ocular pulse pressure (e.g., the pulse of the ophthalmic artery or blinking) or otherwise driving the pumping mechanism externally by impregnating the material and broadcasting a RF or magnetic signal. In some embodiments, the cardiac cycle can produce a pressure wave that impinges on the pump mechanism, creating a pumping effect.

[0136] In some embodiments, pump mechanisms that have larger surface areas (e.g., surface areas of at least about 20 mm^2) can employ ocular pulse pressure to power the pump.

[0137] Further, it has been noted that when the upper and lower eyelids are closed, the pressure of the eyelids on the ocular surface can range from $16.95 \pm 6.08 \text{ mm Hg}$ for the upper lid and $16.11 \pm 7.27 \text{ mm Hg}$ for the lower lid. Accordingly, the pump mechanism can be configured to compress from an expanded state when the pump mechanism undergoes a pressure of between about 5 mm Hg and about 25 mm Hg . In

some embodiments, the pump mechanism can be configured to compress from the expanded state when the pump mechanism undergoes a pressure of between about 8 mm Hg and about 22 mm Hg, between about 10 mm Hg and about 20 mm Hg, between about 12 mm Hg and about 18 mm Hg, or between about 14 mm Hg and about 16 mm Hg.

[0138] The pump mechanism can be configured as an impedance pump based on the Zebrafish heart. Such embodiments can be driven externally by RF energy, magnetic energy, or by the cardiac pump cycle. External energy provided to the pump can be supplied from a user-wearable electronic component, such as glasses, headwear, an implant, or other wearable electronics. Motion within the wall of the aqueous transport member or implant may be induced by magnetic material incorporated into the wall of the aqueous transport member.

[0139] The pump mechanism can also be used in combination with one or more valves that are operative to permit fluid flow in a desired direction(s) through the pump or shunt as pulses or pressure increases are provided. For example, the implant can comprise one or more one-way valves that allow passage of fluid from the anterior chamber towards newly formed episcleral veins. In addition, in some embodiments, the one-way valve can comprise a device utilizing the principles of the embryonic Zebrafish heart, which forms a unicameral chamber.

[0140] In accordance with some embodiments, an ocular implant can comprise a valve (see e.g., the elements 53 in Figures 2–3 and elements 352 in Figures 11–12). In some embodiments, an ocular implant can comprise a pump mechanism and one or two valves (see e.g., Figures 3, 4, 10, or 12–14).

[0141] For example, in some embodiments, the inlet can comprise or be guarded by a first one-way valve. The pump mechanism can also comprise a chamber in fluid communication with the inlet. The pumping chamber can be in fluid communication with an exit that can comprise or be guarded by a second one-way valve. The valves may be mechanical and, according to some embodiments, can be built from unconventional materials. For example, the valve can comprise microvalves, such as self-regulating microfluidic microvalves and carbon fiber nanotubes, hydrogel microvalves, and other suitable mechanisms.

[0142] For example, Figure 10 illustrates an embodiment in which the implant 300 can comprise a valve. For example, the implant 300 illustrated in Figure 10 can

comprise a valve at the inlet 302 and at the inlet 308. Any valve used in such embodiments can be a one-way valve.

[0143] According to some embodiments, pumping mechanisms and intraocular pressure sensors can be used such as those disclosed in U.S. Patent Nos. 6,981,958, 6,638,239, 7,678,065, 7,387,500, and 8,142,364, and U.S. Patent Publication Nos. 2010/0056979 and 2012/0259195, the entireties of each of which are incorporated by reference herein. Further, some commercially available pumps can be used, such as the Zebrafish™ pump.

[0144] In some embodiments, methods are provided in which the trabecular meshwork of a given patient can be measured in order to select a pump size for the patient. However, some embodiments of methods comprise selecting a pump size independently of an actual measurement of a patient's trabecular meshwork.

Additional Methods of Use

[0145] Some embodiments disclosed herein provide methods for placing an intraocular implant having a resorbable portion with a growth factor impregnated therein for the purposes of treating glaucoma. For example, a portion of the implant can extend from the anterior chamber to the episcleral surface of the eye, on top of the sclera. In some embodiments, the placement of the implant can be subconjunctival. Further, in some embodiments, the implant can extend to subtenon placement.

[0146] For example, Figures 13–14 illustrate placement of an ocular implant 500 in the subconjunctival space 510. The implant 500 can be introduced either ab interno or ab externo, and a pump mechanism 502 of the implant 500 can be positioned in the subconjunctival space. A first portion or shunt 504 can be positioned such that it extends from an inlet of the pump mechanism 502 into the anterior chamber 20 of the eye 10. Further, a second portion or shunt 506 can be positioned such that it extends from an outlet of the pump mechanism 502 to a location of lower pressure or lower pressure chamber. The lower pressure chamber can comprise at least one of a supraciliary space, an intrascleral space, a suprachoroidal space, a subconjunctival space 510, episcleral veins, aqueous collector channels, or Schlemm's canal.

[0147] In such an embodiment, the pressure exerted by the eyelid when opened and closed can serve to actuate the pump mechanism 502 in order to drive the pump mechanism 502 and withdraw aqueous humor from the anterior chamber 20.

[0148] After the implant has been placed, the growth factor can facilitate the development of new episcleral veins. Thus, according to some embodiments, the development of new episcleral veins can allow fluid drainage not just into the subconjunctival space, but also into episcleral veins.

[0149] Some embodiments provide methods and apparatuses for fluidly interconnecting episcleral veins with non-blood artificial conduits.

[0150] For example, after an implant has been placed, new episcleral veins can tend to form around the end of outflow portion of the implant. According to some embodiments, new episcleral veins can tend to form around the resorbable portion of the implant that carries or is impregnated with the growth factor. Accordingly, in due course, the resorbable portion will resorb or dissolve into the eye tissue. During this time, the new blood vessels will have formed and will extend toward the non-resorbable portion of the implant. In accordance with some aspects, the dissolution of the resorbable portion can create an open flow area (formerly occupied by the resorbable portion) that can be fluidly interconnected with new episcleral veins. Accordingly, fluid passing through the implant from the anterior chamber can have a new drainage pathway from an artificial conduit to newly formed episcleral veins.

[0151] In addition, some embodiments provide methods for treating hydrocephalus or intracranial hypertension. Hydrocephalus is a condition in which excessive fluid accumulates in the skull and exerts pressure on the brain. The fluid is a cerebrospinal fluid (CSF), a clear fluid that surrounds the brain and spinal cord. The excessive accumulation of CSF causes an abnormal widening of spaces in the brain, which are called ventricles. Potentially harmful pressure on the tissues of the brain can result from the widening of the ventricles.

[0152] Accordingly, in some embodiments, an implant having a growth factor can be placed such that an inflow end is positioned in an area of fluid accumulation in the skull (such as any of the first through fourth ventricles or other areas of fluid accumulation) and an outflow end is positioned distally and adjacent to local vasculature. Over time, the growth factor can stimulate vascular growth and permit the implant to be in direct fluid communication with blood vessels, thereby alleviating intracranial pressure. Thus, the implant can fluidly interconnect blood vessels with a non-blood artificial conduit to the ventricles.

[0153] In yet other applications, the implant can be placed adjacent to another structure to interconnect or improve fluid communication between the structure and the vascular system. In some embodiments, the implant can be placed at a bypass. For example, the bypass can comprise a percutaneous bypass, a femoropopliteal bypass (Fem-Pop bypass) for peripheral arterial disease, or other structures.

[0154] Accordingly, the apparatus and methods discussed herein are not limited to the deployment and use of a medical device within the eye, but may include any number of further treatment applications. Other treatment sites may include areas or regions of the body including any hollow anatomical structures.

[0155] Some embodiments of the implant described herein can incorporate one or more features of implants and/or implant deployment systems

[0156] The foregoing description is provided to enable a person skilled in the art to practice the various configurations described herein. While the subject technology has been particularly described with reference to the various figures and configurations, it should be understood that these are for illustration purposes only and should not be taken as limiting the scope of the subject technology.

[0157] There may be many other ways to implement the subject technology. Various functions and elements described herein may be partitioned differently from those shown without departing from the scope of the subject technology. Various modifications to these configurations will be readily apparent to those skilled in the art, and generic principles defined herein may be applied to other configurations. Thus, many changes and modifications may be made to the subject technology, by one having ordinary skill in the art, without departing from the scope of the subject technology.

[0158] It is understood that the specific order or hierarchy of steps in the processes disclosed is an illustration of exemplary approaches. Based upon design preferences, it is understood that the specific order or hierarchy of steps in the processes may be rearranged. Some of the steps may be performed simultaneously. The accompanying method claims present elements of the various steps in a sample order, and are not meant to be limited to the specific order or hierarchy presented.

[0159] As used herein, the phrase “at least one of” preceding a series of items, with the term “and” or “or” to separate any of the items, modifies the list as a whole, rather than each member of the list (i.e., each item). The phrase “at least one of” does not require selection of at least one of each item listed; rather, the phrase allows a meaning

that includes at least one of any one of the items, and/or at least one of any combination of the items, and/or at least one of each of the items. By way of example, the phrases “at least one of A, B, and C” or “at least one of A, B, or C” each refer to only A, only B, or only C; any combination of A, B, and C; and/or at least one of each of A, B, and C.

[0160] Terms such as “top,” “bottom,” “front,” “rear” and the like as used in this disclosure should be understood as referring to an arbitrary frame of reference, rather than to the ordinary gravitational frame of reference. Thus, a top surface, a bottom surface, a front surface, and a rear surface may extend upwardly, downwardly, diagonally, or horizontally in a gravitational frame of reference.

[0161] Furthermore, to the extent that the term “include,” “have,” or the like is used in the description or the claims, such term is intended to be inclusive in a manner similar to the term “comprise” as “comprise” is interpreted when employed as a transitional word in a claim.

[0162] The word “exemplary” is used herein to mean “serving as an example, instance, or illustration.” Any embodiment described herein as “exemplary” is not necessarily to be construed as preferred or advantageous over other embodiments.

[0163] A reference to an element in the singular is not intended to mean “one and only one” unless specifically stated, but rather “one or more.” Pronouns in the masculine (e.g., his) include the feminine and neuter gender (e.g., her and its) and vice versa. The term “some” refers to one or more. Underlined and/or italicized headings and subheadings are used for convenience only, do not limit the subject technology, and are not referred to in connection with the interpretation of the description of the subject technology. All structural and functional equivalents to the elements of the various configurations described throughout this disclosure that are known or later come to be known to those of ordinary skill in the art are expressly incorporated herein by reference and intended to be encompassed by the subject technology. Moreover, nothing disclosed herein is intended to be dedicated to the public regardless of whether such disclosure is explicitly recited in the above description.

[0164] While certain aspects and embodiments of the inventions have been described, these have been presented by way of example only, and are not intended to limit the scope of the inventions. Indeed, the novel methods and systems described herein may be embodied in a variety of other forms without departing from the spirit thereof.

The accompanying claims and their equivalents are intended to cover such forms or modifications as would fall within the scope and spirit of the inventions.

WHAT IS CLAIMED IS:

1. An intraocular implant comprising:
 - a first tubular member having an inlet and an outlet;
 - a pump body having an inlet and an outlet, the inlet being in fluid communication with the first tubular member outlet, the pump body further comprising a pumping chamber configured to resiliently expand from a compressed state to create a suction force at the first tubular member inlet, the pump body being compressible to expel fluid from the pump body outlet;
 - a first one-way valve coupled to the first tubular member for permitting inflow into the first tubular member inlet and into the pump body inlet;
 - a second tubular member having an inlet and an outlet, the inlet being in fluid communication with the pump body outlet to receive expelled fluid therefrom; and
 - a second one-way valve coupled to the second tubular member for permitting flow into the second tubular member inlet and out through the second tubular member outlet.
2. The implant of Claim 1, wherein the first one-way valve is positioned adjacent to the first tubular member outlet.
3. The implant of any of Claims 1 to 2, wherein the second one-way valve is positioned adjacent to the second tubular member inlet.
4. The implant of any of Claims 1 to 3, wherein the pump body comprises a pumping surface area of from about 1 mm² to about 40 mm².
5. The implant of any of Claims 1 to 4, wherein the second tubular member comprises a growth factor.
6. The implant of Claim 5, wherein the growth factor is coated onto an outlet portion of the second tubular member.
7. The implant of Claim 5, wherein the second tubular member comprises an outlet portion formed from a resorbable material, and wherein the growth factor is impregnated into the resorbable material.
8. The implant of any of Claims 1 to 7, wherein the pump body is compressible using a pulsed pressure of at least 7 mm Hg.
9. The implant of Claim 8, wherein the pump body is compressible using a pulsed pressure of at least 10 mm Hg.

10. The implant of Claim 9, wherein the pump body is compressible using a pulsed pressure of at least 13 mm Hg.

11. The implant of any of Claims 1 to 10, wherein the first tubular member is configured to be inserted into an anterior chamber of an eye, and the second tubular member is configured to extend through a trabecular meshwork and/or sclera of the eye to an outflow space.

12. The implant of any of Claims 1 to 11, wherein the outflow space comprises at least one of a supraciliary space, an intrascleral space, a suprachoroidal space, a subconjunctival space, episcleral veins, aqueous collector channels, or Schlemm's canal.

13. An intraocular implant comprising:

a tubular member having an inlet region configured to extend into an anterior chamber of an eye, and a vascular connecting outlet region (i) extending along a portion of the tubular member and configured to extend into an outflow space comprising at least one of a supraciliary space, an intrascleral space, a suprachoroidal space, a subconjunctival space, episcleral veins, aqueous collector channels, or Schlemm's canal; and

a growth factor carried by the vascular connecting outlet region.

14. The implant of Claim 13, wherein the vascular connecting region comprises at least about half of a length of the tubular member.

15. The implant of any of Claims 13 to 14, wherein the vascular connecting region comprises at least about a third of a length of the tubular member.

16. The implant of any of Claims 13 to 15, wherein the vascular connecting region comprises at least about a fourth of a length of the tubular member.

17. The implant of any of Claims 13 to 16, wherein the vascular connecting region comprises at least about a fifth of a length of the tubular member.

18. The implant of any of Claims 13 to 17, wherein the vascular connecting region comprises at less than about a fifth of a length of the tubular member.

19. The implant of any of Claims 13 to 18, wherein the vascular connecting region comprises a plurality of recesses configured to carry the growth factor therein.

20. The implant of any of Claims 13 to 19, wherein the growth factor comprises a vascular growth factor.

21. The implant of Claim 20, wherein the growth factor comprises a VEGF.

22. The implant of any of Claims 13 to 21, wherein the vascular connecting region comprises a resorbable material and a least a portion of the growth factor.

23. The implant of Claim 22, wherein the vascular connecting region comprises a non-resorbable polymeric material and a plurality of apertures extending in a direction transverse to the stent lumen, the plurality of apertures comprising a resorbable material and the growth factor disposed therein.

24. The implant of Claim 23, wherein the plurality of apertures extend along an entire length of the vascular connecting region.

25. The implant of any of Claims 13 to 24, wherein the vascular connecting region is formed from a resorbable material, and the growth factor is impregnated into the resorbable material.

26. The implant of any of Claims 13 to 25, wherein the growth factor comprises a coating on the vascular connecting region.

27. The implant of any of Claims 13 to 26, further comprising a pump for urging fluid through the implant.

28. The implant of Claim 27, wherein the pump is configured to operate using ocular pulse pressure.

29. The implant of Claim 28, wherein the pump comprises a one-way valve.

30. The implant of any of Claims 13 to 29, further comprising a one-way valve for facilitating fluid flow through the implant.

31. An intraocular implant comprising:

a tubular member having an inlet region configured to extend into an anterior chamber of an eye, and a vascular connecting outlet region (i) extending along a portion of the tubular member and configured to extend into an outflow space comprising at least one of a supraciliary space, an intrascleral space, a suprachoroidal space, a subconjunctival space, episcleral veins, aqueous collector channels, or Schlemm's canal; and

a pump mechanism fluidly coupled to the inlet region, the pump mechanism having a pumping chamber that defines a pumping surface area of from about 1 mm² to about 40 mm².

32. The implant of Claim 31, wherein the pumping surface area is from about 1 mm² to about 25 mm².

33. The implant of any of Claims 31 to 32, wherein the pumping surface area is from about 1 mm² to about 15 mm².

34. The implant of any of Claims 31 to 33, wherein the pumping surface area is from about 1 mm² to about 10 mm².

35. A method of deploying an intraocular implant into an eye for stimulating vascular growth, the method comprising:

inserting into the eye a deployment member carrying the implant;

releasing the implant from the deployment member such that an inflow region of the implant resides in a higher pressure chamber of the eye and a vascular connecting region of the implant resides in a location of lower pressure chamber of the eye, the implant having a lumen to conduct fluid therethrough, the vascular connecting region of the implant carrying a growth factor for promoting growth of blood vessels adjacent to the vascular connecting region within the lower pressure chamber to facilitate aqueous humor outflow from the higher pressure chamber; and

withdrawing the deployment member from the eye.

36. The method of Claim 35, wherein the growth factor comprises a vascular growth factor selected from the group consisting of a VEGF isoform.

37. The method of any of Claims 35 to 36, wherein the growth factor comprises a VEGF.

38. The method of any of Claims 35 to 37, wherein the lower pressure chamber comprises at least one of a supraciliary space, an intrascleral space, a suprachoroidal space, a subconjunctival space, episcleral veins, aqueous collector channels, or Schlemm's canal.

39. The method of any of Claims 35 to 38, wherein the higher pressure chamber comprises the anterior chamber.

40. The method of any of Claims 35 to 39, wherein the vascular connecting region comprises a resorbable material and at least a portion of the growth factor.

41. The method of Claim 40, wherein the vascular connecting region comprises a non-resorbable polymeric material having a plurality of apertures extending in a direction transverse to the stent lumen, the plurality of apertures comprising a resorbable material and the growth factor disposed therein.

42. The method of any of Claims 40 to 41, wherein the growth factor is impregnated into the resorbable material.

43. The method of any of Claims 35 to 42, wherein the growth factor is impregnated into the vascular connecting region.

44. The method of Claim 43, wherein the vascular connecting region comprises a resorbable material.

45. The method of any of Claims 35 to 44, wherein the growth factor comprises a coating on the vascular connecting region.

46. A method of placing an intraocular implant for stimulating vascular growth, the method comprising implanting the implant into the eye such that a non-resorbable portion of the implant resides in a higher pressure chamber of the eye and a resorbable portion resides in a location of lower pressure chamber of the eye, the implant having a lumen extending therethrough, the resorbable portion comprising a growth factor for stimulating growth of new blood vessels, the resorbable portion configured to dissolve such that the new blood vessels converge toward the implant non-resorbable portion extending from the higher pressure chamber of the eye thereby enabling the implant lumen to be in fluid communication with the new blood vessels to facilitate aqueous humor outflow from the higher pressure chamber.

47. The method of Claim 46, wherein the growth factor comprises a vascular growth factor.

48. The method of Claim 47, wherein the growth factor comprises a VEGF.

49. The method of any of Claims 46 to 48, wherein the lower pressure chamber comprises at least one of a supraciliary space, an intrascleral space, a suprachoroidal space, a subconjunctival space, episcleral veins, aqueous collector channels, or Schlemm's canal, and the growth factor promotes growth of episcleral veins.

50. The method of any of Claims 46 to 49, wherein the higher pressure chamber comprises the anterior chamber.

51. A method of facilitating drainage of aqueous humor from a higher pressure chamber to a lower pressure chamber of an eye, the method comprising inserting an artificial non-blood fluid conduit into the eye to fluidly interconnects the higher pressure chamber with the lower pressure chamber, the conduit having a growth factor for stimulating growth of new blood vessels adjacent the lower pressure chamber to connect the new blood vessels with the non-blood fluid conduit.

52. The method of Claim 51, wherein the higher pressure chamber comprises the anterior chamber.

53. The method of any of Claims 51 to 52, wherein the lower pressure chamber comprises at least one of a supraciliary space, an intrascleral space, a suprachoroidal space, a subconjunctival space, episcleral veins, aqueous collector channels, or Schlemm's canal.

54. A method of deploying an intraocular implant into an eye, the method comprising:

inserting into the eye a deployment member carrying the implant of any of Claims 1 to 34;

releasing the implant from the deployment member such that (i) an inflow region of the implant resides in an anterior chamber of the eye, (ii) a pump body is positioned in subconjunctival space, and (iii) an outflow region resides in the subconjunctival space; and

withdrawing the deployment member from the eye.

55. The method of Claim 54, wherein the inserting comprises piercing the cornea to perform the method ab interno.

56. The method of any of Claims 54 to 55, wherein the inserting comprises advancing the deployment member through sclera to perform the method ab externo.

57. The method of any of Claims 54 to 56, wherein the releasing comprises positioning the pump body between the cornea and a rectus muscle of the eye.

58. The method of any of Claims 54 to 58, wherein the outflow region comprises a growth factor.

59. The method of Claim 58, wherein the growth factor comprises a VEGF.

60. The method of any of Claims 54 to 59, wherein the higher pressure chamber comprises the anterior chamber.

61. The method of any of Claims 54 to 60, wherein the lower pressure chamber comprises at least one of a supraciliary space, an intrascleral space, a suprachoroidal space, a subconjunctival space, episcleral veins, aqueous collector channels, or Schlemm's canal.

62. An implant comprising any of the features or structures disclosed herein.

63. A method of placing an implant comprising: placing an implant having any of the features or structures disclosed herein; and placing the implant to interconnect any of the bodily spaces disclosed herein with a location of lower pressure.

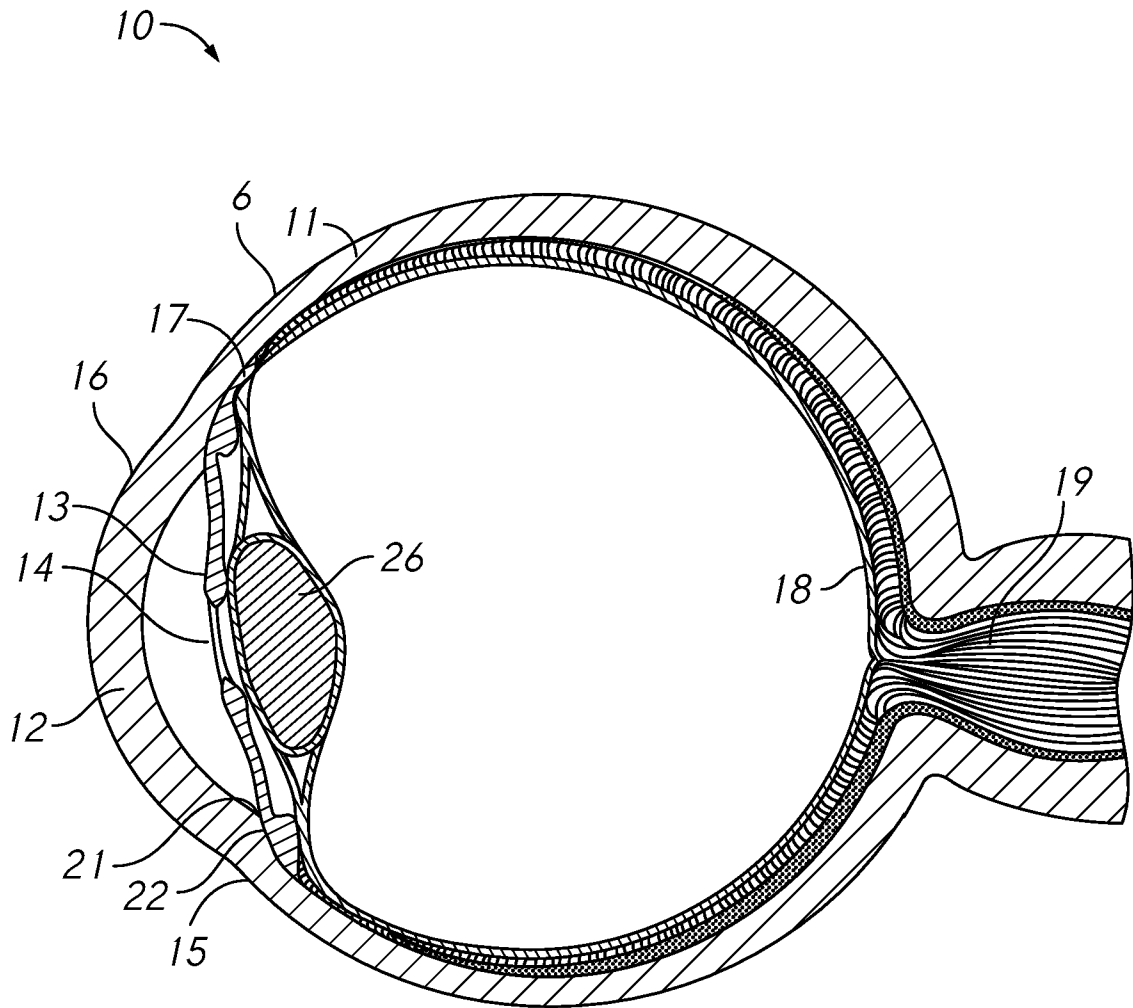

FIG. 1

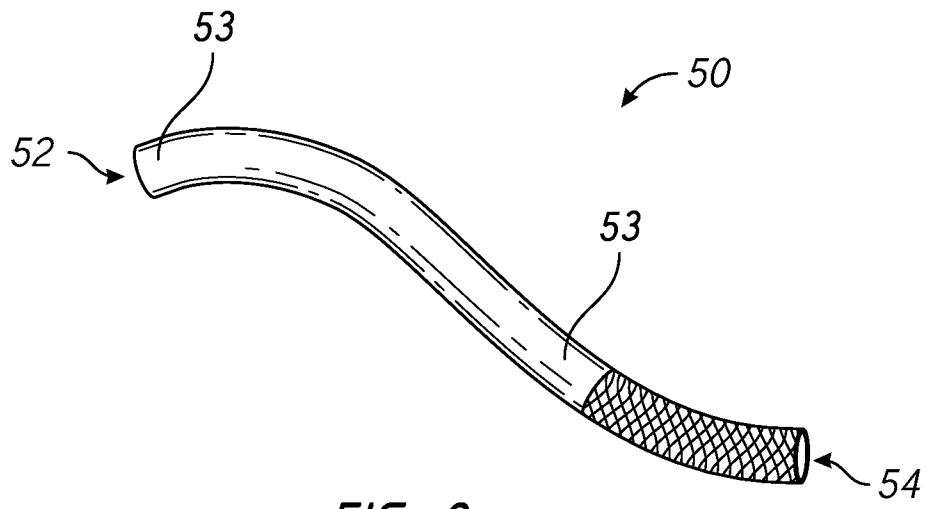

FIG. 2

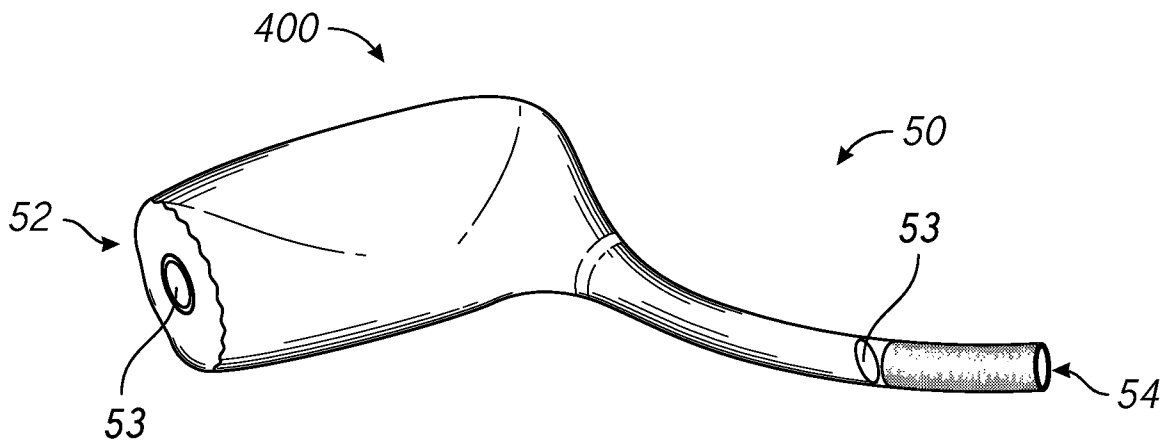

FIG. 3

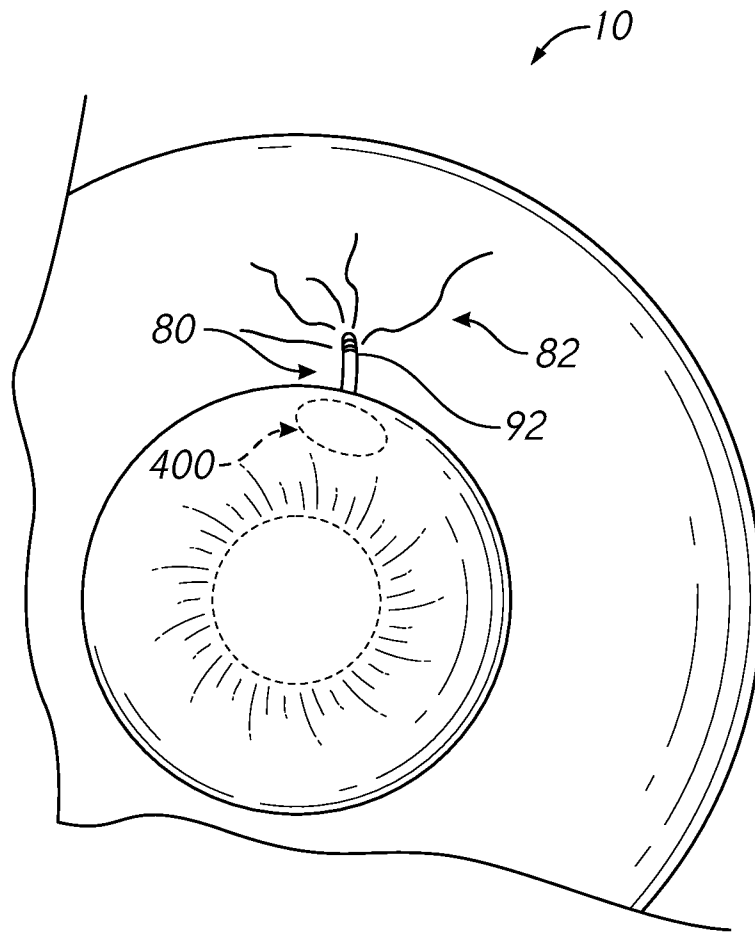

FIG. 4

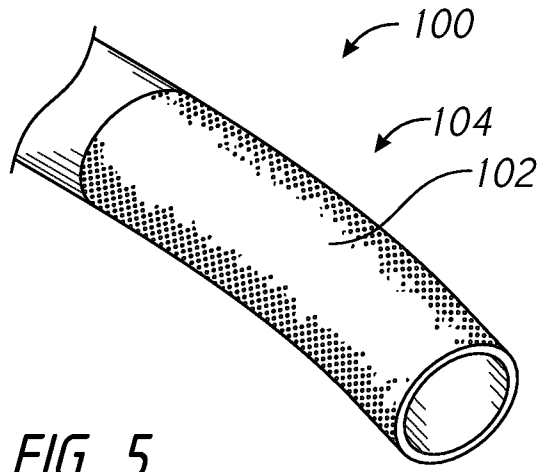

FIG. 5

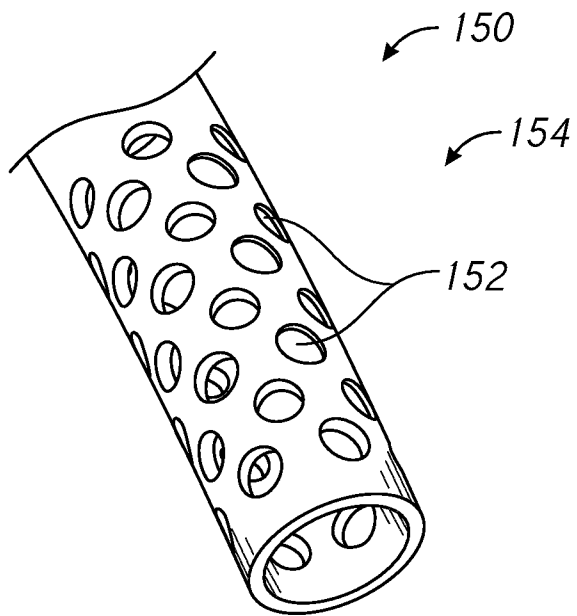

FIG. 6

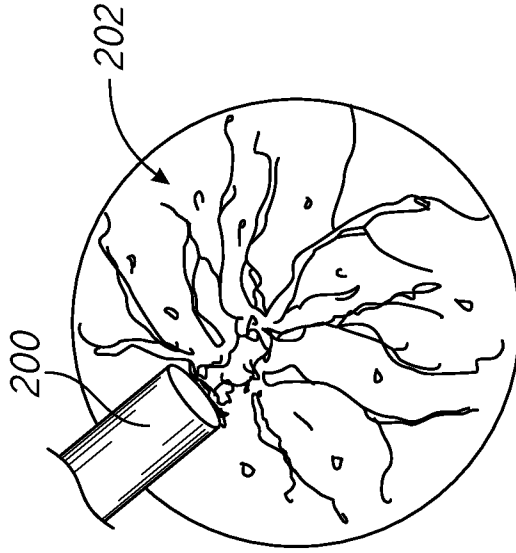

FIG. 7

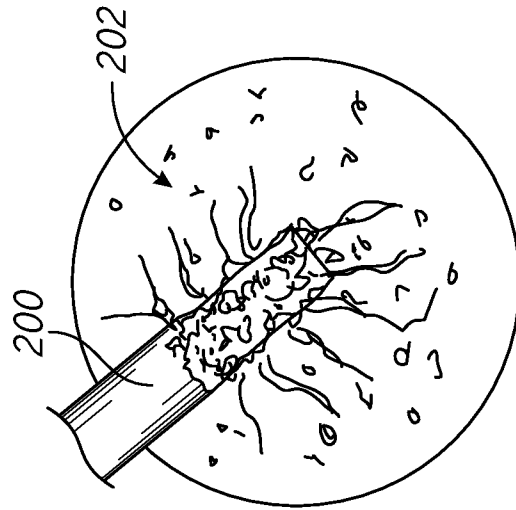

FIG. 8

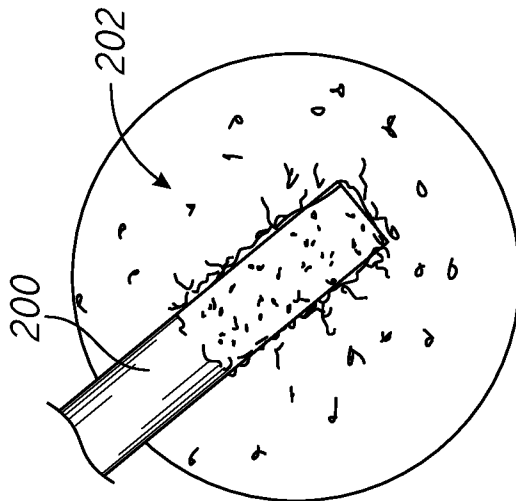

FIG. 9

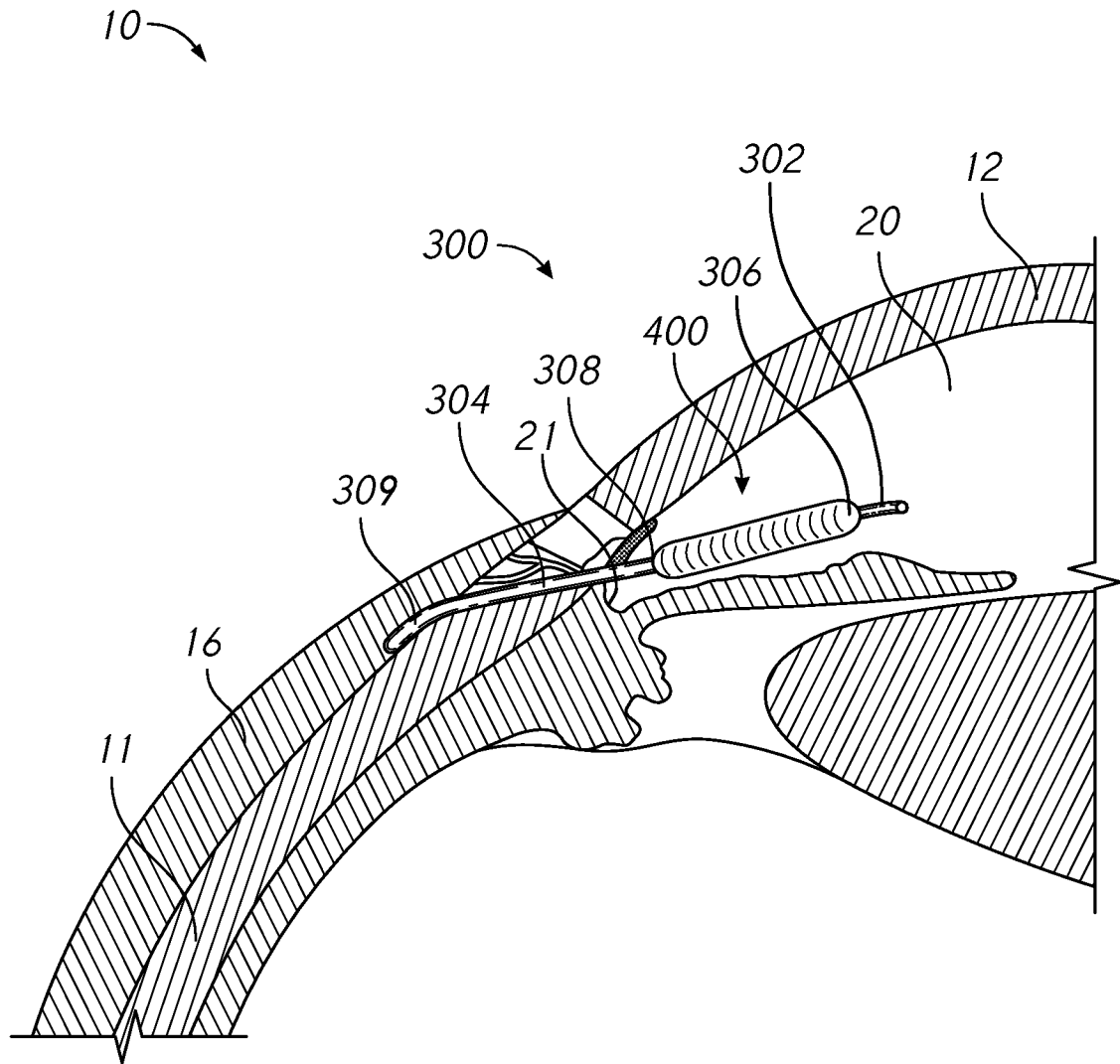

FIG. 10

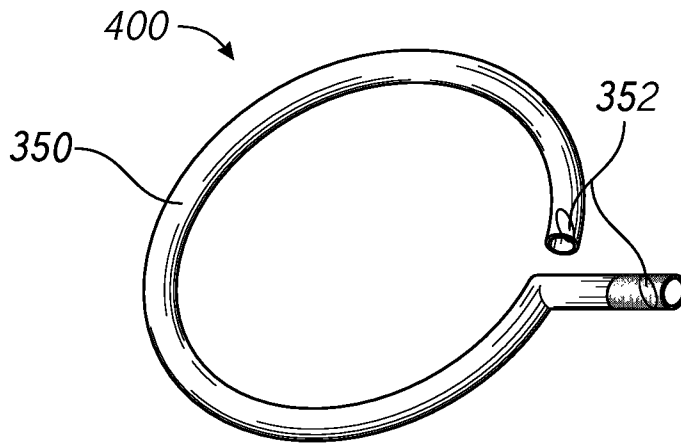

FIG. 11

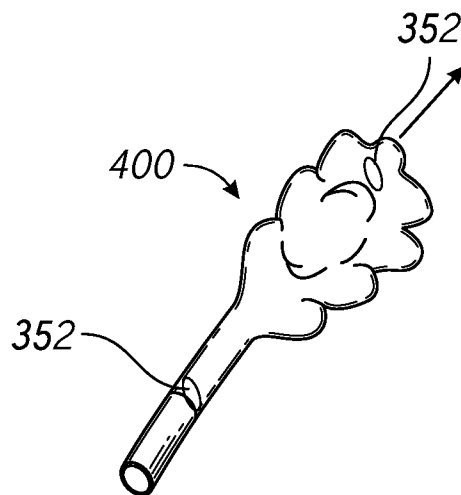

FIG. 12

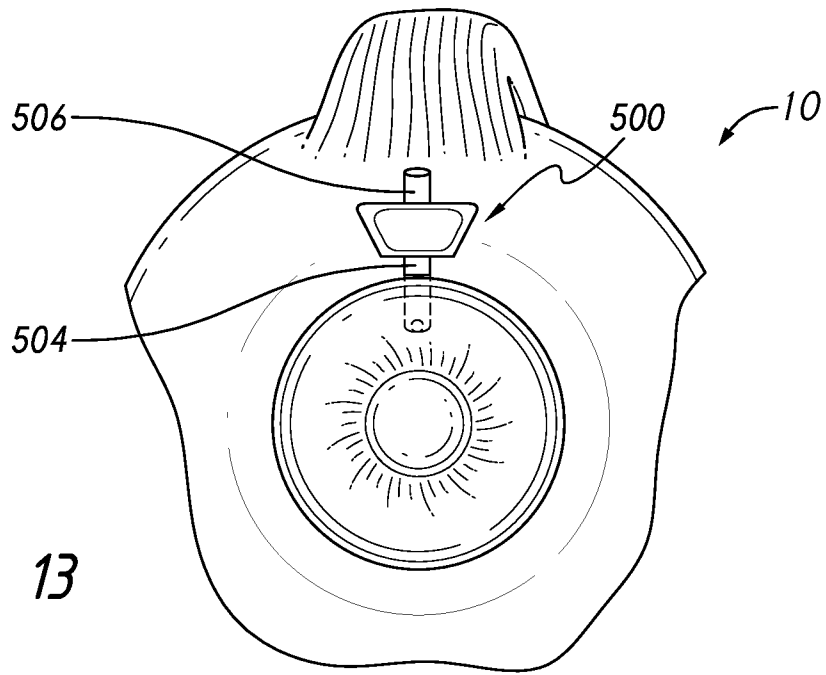

FIG. 13

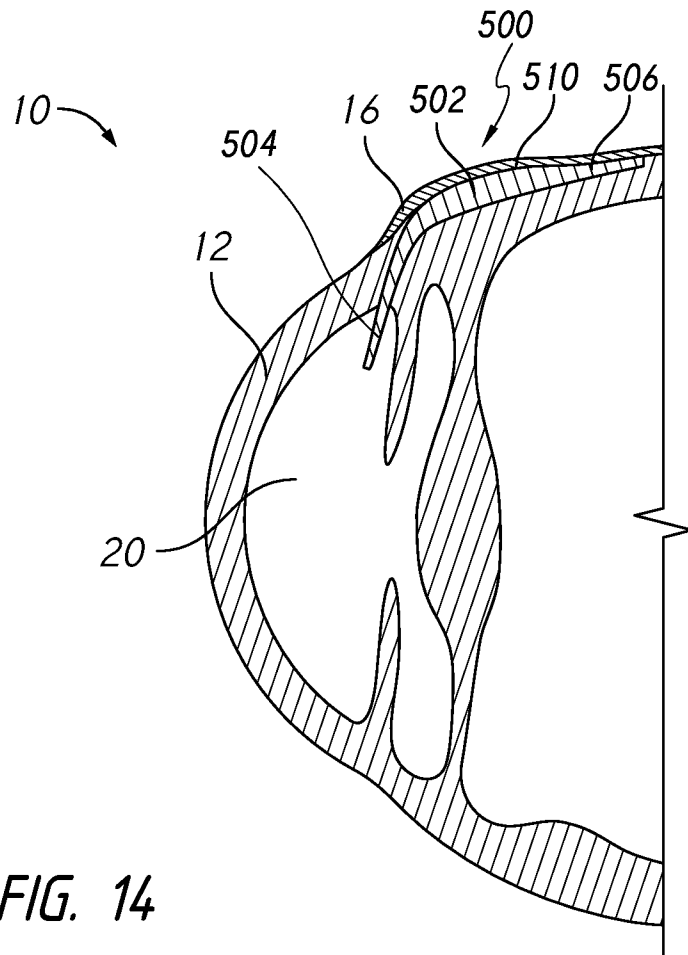

FIG. 14

INTERNATIONAL SEARCH REPORT

International application No.
PCT/US2014/029657**A. CLASSIFICATION OF SUBJECT MATTER****A61F 2/14(2006.01)i, A61F 9/00(2006.01)i**

According to International Patent Classification (IPC) or to both national classification and IPC

B. FIELDS SEARCHED

Minimum documentation searched (classification system followed by classification symbols)

A61F 2/14; A61K 9/22; A61K 9/00; A61F 9/00; A61F 11/00; A61M 5/00

Documentation searched other than minimum documentation to the extent that such documents are included in the fields searched

Korean utility models and applications for utility models

Japanese utility models and applications for utility models

Electronic data base consulted during the international search (name of data base and, where practicable, search terms used)

eKOMPASS(KIPO internal) & Keywords: intraocular implant, ocular, eye, drain, tubular, conduit, shunt

C. DOCUMENTS CONSIDERED TO BE RELEVANT

Category*	Citation of document, with indication, where appropriate, of the relevant passages	Relevant to claim No.
X	US 2005-0049578 A1 (TU, H. et al.) 3 March 2005 See abstract; claims 1-2, 4-5; paragraph [0083]; figure 5.	1-3,31-33
Y		13-15
Y	WO 2012-071476 A2 (HAFFNER, D. et al.) 31 May 2012 See claims 1, 14; figures 2-3B.	13-15
A		1-3,31-33
A	US 8206440 B2 (GUARNIERI, F. A.) 26 June 2012 See abstract; claim 1; column 4, line 58-column 5, line 10; figures 1A-1B.	1-3,13-15,31-33
A	US 7780623 B2 (SOLTANPOUR, D. P.) 24 August 2010 See abstract; claim 1; column 4, line 56-column 5, line 26; figures 2A-2B.	1-3,13-15,31-33
A	US 2007-0191863 A1 (DE JUAN, JR. E. et al.) 16 August 2007 See abstract; claim 74; paragraphs [0186], [0194]; figures 37, 45.	1-3,13-15,31-33

 Further documents are listed in the continuation of Box C. See patent family annex.

* Special categories of cited documents:

"A" document defining the general state of the art which is not considered to be of particular relevance

"E" earlier application or patent but published on or after the international filing date

"L" document which may throw doubts on priority claim(s) or which is cited to establish the publication date of another citation or other special reason (as specified)

"O" document referring to an oral disclosure, use, exhibition or other means

"P" document published prior to the international filing date but later than the priority date claimed

"T" later document published after the international filing date or priority date and not in conflict with the application but cited to understand the principle or theory underlying the invention

"X" document of particular relevance; the claimed invention cannot be considered novel or cannot be considered to involve an inventive step when the document is taken alone

"Y" document of particular relevance; the claimed invention cannot be considered to involve an inventive step when the document is combined with one or more other such documents, such combination being obvious to a person skilled in the art

"&" document member of the same patent family

Date of the actual completion of the international search

04 July 2014 (04.07.2014)

Date of mailing of the international search report

07 July 2014 (07.07.2014)

Name and mailing address of the ISA/KR

International Application Division
Korean Intellectual Property Office
189 Cheongsu-ro, Seo-gu, Daejeon Metropolitan City, 302-701,
Republic of Korea

Facsimile No. +82-42-472-7140

Authorized officer

Han, Inho

Telephone No. +82-42-481-3362



Box No. II Observations where certain claims were found unsearchable (Continuation of item 2 of first sheet)

This international search report has not been established in respect of certain claims under Article 17(2)(a) for the following reasons:

1. Claims Nos.: 35-61, 63
because they relate to subject matter not required to be searched by this Authority, namely:
Claims 35-61, 63 pertain to methods for treatment of the human and thus relate to a subject-matter which this International Searching Authority is not required, under PCT Article 17(2)(a)(i) and PCT Rule 39.1(iv), to search.
2. Claims Nos.: 6-7,9-10,21,23-24,28-29,41,44,55, 59, 62
because they relate to parts of the international application that do not comply with the prescribed requirements to such an extent that no meaningful international search can be carried out, specifically:
 - Claims 6-7,9-10,21,23-24,28-29,41,44,55, 59 are unclear, because they refer to multiple dependent claims which do not comply with PCT Rule 6.4(a).
 - Since claim 62 does not contain the essential feature for the implant, claim 62 does not comply with PCT Article 6.
3. Claims Nos.: 4-5,8,11-12,16-20,22,25-27,30,34,38-40,42-43,45,50,54,56-58,60-61
because they are dependent claims and are not drafted in accordance with the second and third sentences of Rule 6.4(a).

Box No. III Observations where unity of invention is lacking (Continuation of item 3 of first sheet)

This International Searching Authority found multiple inventions in this international application, as follows:

1. As all required additional search fees were timely paid by the applicant, this international search report covers all searchable claims.
2. As all searchable claims could be searched without effort justifying an additional fees, this Authority did not invite payment of any additional fees.
3. As only some of the required additional search fees were timely paid by the applicant, this international search report covers only those claims for which fees were paid, specifically claims Nos.:
4. No required additional search fees were timely paid by the applicant. Consequently, this international search report is restricted to the invention first mentioned in the claims; it is covered by claims Nos.:

Remark on Protest

- The additional search fees were accompanied by the applicant's protest and, where applicable, the payment of a protest fee.
- The additional search fees were accompanied by the applicant's protest but the applicable protest fee was not paid within the time limit specified in the invitation.
- No protest accompanied the payment of additional search fees.

INTERNATIONAL SEARCH REPORT

Information on patent family members

International application No.

PCT/US2014/029657

Patent document cited in search report	Publication date	Patent family member(s)	Publication date
US 2005-0049578 A1	03/03/2005	AU 2001-245522 B2	27/10/2005
		AU 2001-45522 A1	30/10/2001
		AU 2001-61262 A1	15/05/2002
		AU 2002-258754 B2	17/08/2006
		AU 2003-264014 A1	25/02/2004
		AU 2003-264014 B2	17/07/2008
		AU 2004-264913 A1	24/02/2005
		AU 2004-264913 B2	25/08/2011
		CA 2404037 A1	25/10/2001
		CA 2409947 A1	08/05/2003
		CA 2442652 A1	17/10/2002
		CA 2488393 A1	19/02/2004
		CA 2530234 A1	24/02/2005
		CA 2581334 A1	06/04/2006
		CA 2683224 A1	17/10/2002
		CA 2718294 A1	17/10/2002
		CA 2791154 A1	25/10/2001
		EP 1278492 A2	29/01/2003
		EP 1278492 B1	29/04/2009
		EP 1310222 A2	14/05/2003
		EP 1310222 A3	17/03/2004
		EP 1418868 A2	19/05/2004
		EP 1418868 B1	26/03/2008
		EP 1545655 A2	29/06/2005
		EP 1545655 A4	31/05/2006
		EP 1545655 B1	31/12/2008
		EP 1651291 A1	03/05/2006
		EP 1651291 B1	13/03/2013
		EP 1977724 A1	08/10/2008
		EP 2078516 A2	15/07/2009
		EP 2078516 A3	04/11/2009
		EP 2078516 B1	02/01/2013
		EP 2260803 A2	15/12/2010
		EP 2260803 A3	16/03/2011
		EP 2263621 A1	22/12/2010
		EP 2351589 A1	03/08/2011
		EP 2351589 B1	06/11/2013
		JP 2003-180730 A	02/07/2003
		JP 2004-500220 A	08/01/2004
		JP 2005-512607 A	12/05/2005
		JP 2005-535392 A	24/11/2005
		JP 2007-181714 A	19/07/2007
		JP 2007-501066 A	25/01/2007
		JP 2009-056324 A	19/03/2009
		JP 2011-092765 A	12/05/2011
		JP 2013-009982 A	17/01/2013
		JP 2013-066742 A	18/04/2013
		JP 2013-208434 A	10/10/2013
		US 2002-0143284 A1	03/10/2002

INTERNATIONAL SEARCH REPORT

Information on patent family members

International application No.

PCT/US2014/029657

Patent document cited in search report	Publication date	Patent family member(s)	Publication date
		US 2002-0165478 A1	07/11/2002
		US 2002-0188308 A1	12/12/2002
		US 2003-0060752 A1	27/03/2003
		US 2003-0088260 A1	08/05/2003
		US 2003-0120200 A1	26/06/2003
		US 2003-0181848 A1	25/09/2003
		US 2003-0187384 A1	02/10/2003
		US 2003-0187385 A1	02/10/2003
		US 2003-0191428 A1	09/10/2003
		US 2004-0102729 A1	27/05/2004
		US 2004-0111050 A1	10/06/2004
		US 2004-0127843 A1	01/07/2004
		US 2004-0147870 A1	29/07/2004
		US 2004-0210185 A1	21/10/2004
		US 2004-0249333 A1	09/12/2004
		US 2004-0254519 A1	16/12/2004
		US 2004-0254520 A1	16/12/2004
		US 2005-0119636 A1	02/06/2005
		US 2005-0192527 A1	01/09/2005
		US 2005-0209549 A1	22/09/2005
		US 2005-0209550 A1	22/09/2005
		US 2005-0266047 A1	01/12/2005
		US 2005-0271704 A1	08/12/2005
		US 2005-0277864 A1	15/12/2005
		US 2005-0288619 A1	29/12/2005
		US 2006-0074375 A1	06/04/2006
		US 2006-0084907 A1	20/04/2006
		US 2006-0195055 A1	31/08/2006
		US 2006-0195056 A1	31/08/2006
		US 2007-0112292 A1	17/05/2007
		US 2007-0118147 A1	24/05/2007
		US 2007-0276315 A1	29/11/2007
		US 2007-0276316 A1	29/11/2007
		US 2007-0282244 A1	06/12/2007
		US 2007-0282245 A1	06/12/2007
		US 2008-0045878 A1	21/02/2008
		US 2008-0200860 A1	21/08/2008
		US 2008-0234624 A2	25/09/2008
		US 2009-0076436 A2	19/03/2009
		US 2009-0137983 A1	28/05/2009
		US 2009-0138022 A1	28/05/2009
		US 2009-0138081 A1	28/05/2009
		US 2009-0143712 A1	04/06/2009
		US 2010-0010414 A1	14/01/2010
		US 2010-0056979 A1	04/03/2010
		US 2010-0087774 A1	08/04/2010
		US 2010-0106073 A1	29/04/2010
		US 2010-0234790 A1	16/09/2010
		US 2011-0092878 A1	21/04/2011
		US 2011-0105987 A1	05/05/2011

INTERNATIONAL SEARCH REPORT

Information on patent family members

International application No.

PCT/US2014/029657

Patent document cited in search report	Publication date	Patent family member(s)	Publication date
		US 6638239 B1	28/10/2003
		US 6666841 B2	23/12/2003
		US 6736791 B1	18/05/2004
		US 6780164 B2	24/08/2004
		US 6955656 B2	18/10/2005
		US 6981958 B1	03/01/2006
		US 7135009 B2	14/11/2006
		US 7163543 B2	16/01/2007
		US 7297130 B2	20/11/2007
		US 7431710 B2	07/10/2008
		US 7488303 B1	10/02/2009
		US 7563241 B2	21/07/2009
		US 7678065 B2	16/03/2010
		US 7708711 B2	04/05/2010
		US 7857782 B2	28/12/2010
		US 7867186 B2	11/01/2011
		US 7867205 B2	11/01/2011
		US 7879001 B2	01/02/2011
		US 7951155 B2	31/05/2011
		US 8007459 B2	30/08/2011
		US 8062244 B2	22/11/2011
		US 8075511 B2	13/12/2011
		US 8142364 B2	27/03/2012
		US 8273050 B2	25/09/2012
		US 8333742 B2	18/12/2012
		US 8348877 B2	08/01/2013
		WO 01-78631 A2	25/10/2001
		WO 01-78631 A3	18/04/2002
		WO 02-080811 A2	17/10/2002
		WO 02-087418 A2	07/11/2002
		WO 02-087418 A3	27/11/2003
		WO 02-36052 A1	10/05/2002
		WO 2002-080811 A3	11/03/2004
		WO 2004-014218 A2	19/02/2004
		WO 2004-014218 A3	05/08/2004
		WO 2005-016418 A1	24/02/2005
		WO 2006-036715 A2	06/04/2006
		WO 2006-036715 A3	07/06/2007
WO 2012-071476 A2	31/05/2012	EP 2654715 A2	30/10/2013
		US 2013-0289467 A1	31/10/2013
		WO 2012-071476 A3	09/08/2012
US 8206440 B2	26/06/2012	AR 058947 A1	05/03/2008
		CA 2674899 A1	17/07/2008
		EP 2104480 A2	30/09/2009
		EP 2104480 B1	10/04/2013
		JP 2010-515476 A	13/05/2010
		US 2010-0042209 A1	18/02/2010
		WO 2008-084350 A2	17/07/2008

INTERNATIONAL SEARCH REPORT

Information on patent family members

International application No.

PCT/US2014/029657

Patent document cited in search report	Publication date	Patent family member(s)	Publication date
		WO 2008-084350 A3	23/10/2008
		WO 2008-084350 B1	11/12/2008
US 7780623 B2	24/08/2010	EP 1297255 A1	02/04/2003
		US 2002-0013545 A1	31/01/2002
		US 2007-0106199 A1	10/05/2007
		US 6589198 B1	08/07/2003
		US 6682500 B2	27/01/2004
		WO 01-94784 A1	13/12/2001
		WO 99-38470 A2	05/08/1999
US 2007-0191863 A1	16/08/2007	AU 2006-336598 A1	02/08/2007
		AU 2006-336598 B2	10/10/2013
		CA 2637602 A1	26/07/2007
		CA 2637656 A1	02/08/2007
		EP 1978892 A2	15/10/2008
		EP 1979023 A2	15/10/2008
		EP 1979023 A4	31/10/2012
		EP 2526910 A1	28/11/2012
		JP 2009-523540 A	25/06/2009
		JP 2009-523545 A	25/06/2009
		JP 2012-125606 A	05/07/2012
		US 2010-0010416 A1	14/01/2010
		US 2011-0028883 A1	03/02/2011
		US 2011-0098629 A1	28/04/2011
		US 8721656 B2	13/05/2014
		WO 2007-084582 A2	26/07/2007
		WO 2007-084582 A3	21/12/2007
		WO 2007-087061 A2	02/08/2007
		WO 2007-087061 A3	13/12/2007